

TM 9-2320-312-24-2

TECHNICAL MANUAL

UNIT, DIRECT SUPPORT, AND GENERAL SUPPORT MAINTENANCE MANUAL

FOR

**TRUCK, TRACTOR, YARD TYPE:
46,662 GVWR, DED, 4 X 2, M878A2
(NSN 2320-01-452-5579)**



Approved for public release; distribution is unlimited.

HEADQUARTERS, DEPARTMENT OF THE ARMY

DECEMBER 2003

WARNING SUMMARY

This warning summary contains general safety warnings and hazardous materials warnings that must be understood and applied during operation and maintenance of this equipment. Failure to observe these precautions could result in serious injury or death to personnel. Also included are explanations of safety and hazardous materials icons used within the technical manual.



BIOLOGICAL - abstract symbol bug shows that a material may contain bacteria or viruses that present a danger to life or health.



CHEMICAL - drops of liquid on hand shows that the material will cause burns or irritation to human skin or tissue.



EAR PROTECTION - Headphones over ears show that noise level will harm ears.



ELECTRICAL - electrical wire to arm with electricity symbol running through human body shows that shock hazard is present.



EYE PROTECTION - person with goggles shows that the material will injure the eyes.



FIRE - flame shows that a material may ignite and cause burns.

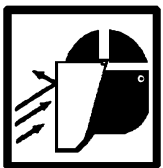

FLYING PARTICLES - arrows bouncing off face with face shield shows that particles flying through the air will harm face.



HEAVY OBJECT - human figure stooping over heavy object shows physical injury potential from improper lifting technique.



HEAVY PARTS - hand with heavy object on top shows that heavy parts can crush and harm.



HEAVY PARTS - heavy object on human figure shows that heavy parts present a danger to life or limb.



HOT AREA - hand over object radiating heat shows that part is hot and can burn.



HYDRAULIC FLUID PRESSURE - hydraulic fluid spraying human figure shows that fluid escaping under great pressure can cause injury or death.



RADIOACTIVE - identifies a material that emits radioactive energy and can injure human tissue or organs.



VAPOR - human figure in a cloud shows that material vapors present a danger to life or health.

FOR INFORMATION ON FIRST AID, REFER TO FM 4-25.11



WARNING

CARBON MONOXIDE (EXHAUST GASES) CAN KILL!

- Carbon monoxide is a colorless, odorless, deadly poison which, when breathed, deprives the body of oxygen and causes suffocation. Exposure to air containing carbon monoxide produces symptoms of headache, dizziness, loss of muscular control, apparent drowsiness, and coma. Permanent brain damage or death can result from severe exposure.
 - Carbon monoxide occurs in exhaust fumes of internal combustion engines. Carbon monoxide can become dangerously concentrated under conditions of inadequate ventilation. The following precautions must be observed to ensure safety of personnel when engine of tractor is operated.
1. DO NOT operate tractor engine in enclosed areas without adequate ventilation.
 2. DO NOT idle tractor engine without adequate ventilation.
 3. DO NOT drive tractor with inspection plates or cover plates removed.
 4. BE ALERT for exhaust poisoning symptoms. They are:
 - Headache
 - Dizziness
 - Sleepiness
 - Loss of muscular control
 5. If you see another person with exhaust poisoning symptoms:
 - Remove person from area.
 - Expose to fresh air.
 - Keep person warm.
 - Do not permit physical exercise.
 - Administer cardiopulmonary resuscitation (CPR), if necessary.
 - Notify a medic.
 6. BE AWARE. The field protective mask for nuclear-biological-chemical (NBC) protection will not protect you from carbon monoxide poisoning.

The Best Defense Against Carbon Monoxide Poisoning Is Good Ventilation!

WARNING

AIRBRAKE SYSTEM

- DO NOT disconnect any air lines or fittings unless engine is shut down and air system pressure is relieved. Failure to follow this warning could result in serious injury to personnel.
- Brake chamber contains spring under great pressure. To prevent personnel injury, avoid working directly behind chamber. If caging bolt will not engage properly, spring may be broken.
- DO NOT remove clamp ring around spring brake chamber. It is under tension and can cause personnel injury if released.



WARNING
BATTERIES



- To avoid injury, eye protection and acid-resistant gloves must be worn when working around batteries. Do not smoke, use open flame, make sparks or create other ignition sources around batteries. If a battery is giving off gases, it can explode and cause injury to personnel. Remove all jewelry such as rings, ID tags, watches, and bracelets. If jewelry or a tool contacts a battery terminal, a direct short will result in instant heating or electric shock, damage to equipment, and injury to personnel.
 - Sulfuric acid contained in batteries can cause serious burns. If battery corrosion or electrolyte makes contact with skin, eyes or clothing, take immediate action to stop the corrosive burning effects. Failure to follow these procedures may result in death or serious injury to personnel.
- a. **Eyes.** Flush with cold water for no less than 15 minutes and seek medical attention immediately.
 - b. **Skin.** Flush with large amounts of cold water until all acid is removed. Seek medical attention as required.
 - c. **Internal.** If corrosion or electrolyte is ingested, drink large amounts of water or milk. Follow with milk of magnesia, beaten egg or vegetable oil. Seek medical attention immediately.
 - d. **Clothing/Equipment.** Wash area with large amounts of cold water. Neutralize acid with baking soda or household ammonia.



WARNING
CAB TILT SYSTEM

- Ensure that no part of body is under cab while tilting. Stand clear of front and rear of cab while it is being raised. Ensure that tools and supplies are removed from cab and that cab doors are securely closed before tilting cab. Failure to do so may result in injury to personnel.
- Always check that cab tilt safety prop is properly engaged before working under cab. Cab could fall and cause serious injury or death.
- Ensure cab latch fully engages after lowering cab. If cab latch is not engaged, cab could tilt while in motion. Failure to follow this warning may result in injury or death to personnel.



WARNING
CAPACITOR(S)



- To avoid injury, eye protection, protective clothing, and gloves must be worn when working around capacitors. Capacitors contain an electrolyte that is a potassium hydroxide solution. Potassium hydroxide is highly corrosive and can cause serious burns. If capacitor case becomes cracked, leaking electrolyte can result in fumes that are hazardous to inhale. If electrolyte makes contact with skin, eyes or clothing, take immediate action to stop the corrosive burning effects. Failure to follow these procedures may result in death or serious injury to personnel.
 - a. **Eyes.** Flush with plenty of water for at least 15 minutes, occasionally lifting upper and lower eyelids. Seek medical attention immediately.
 - b. **Skin.** Wash with soap and water for at least 15 minutes, while removing contaminated clothing and shoes. Dispose of contaminated clothing in a manner that limits further exposure. Seek medical attention immediately.
 - c. **Ingestion.** Do NOT induce vomiting. Drink 2-4 cups of milk or water. Seek medical attention immediately.
 - d. **Inhalation.** Remove from exposure to fresh air immediately. If not breathing, give CPR (cardio-pulmonary resuscitation). If breathing is difficult, administer oxygen. Seek medical attention immediately.
- Remove all jewelry such as rings, ID tags, watches, and bracelets, when working around capacitors. If jewelry or a tool contacts a capacitor terminal, a direct short may result, causing instant heating and electric shock at the point of short circuit. Damage to equipment and injury to personnel could result.

WARNING

CLEANING AGENTS

Improper cleaning methods and use of unauthorized cleaning agents can injure personnel and damage equipment. To prevent this, refer to TM 9-247 for further instructions.

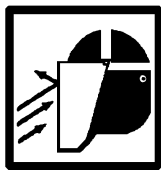

WARNING
COMPRESSED AIR

Compressed air used for cleaning purposes should never exceed 30 psi (207 kPa). Wear protective clothing (goggles/shield, gloves, etc.) and use caution to avoid injury to personnel.



WARNING
COOLANT HANDLING

Wear protective gloves when handling coolants. If exposed to coolant, promptly wash exposed skin and change coolant-soaked clothing. Failure to follow this warning may result in injury to personnel.



WARNING

DRY CLEANING SOLVENT



Dry cleaning solvent MIL-PRF-680 Type III is an environmentally compliant and low toxic material. However, it may be irritating to the eyes and skin. The use of protective gloves and goggles is suggested. Use in well-ventilated areas. Keep away from open flames and other sources of ignition.



WARNING

ELECTRICAL SYSTEM MAINTENANCE

Remove all jewelry, watches, rings, etc. prior to disconnecting cables from batteries or other electrical source. Items can come in contact with battery or electrical source and cause electrical shock. Failure to follow this warning may result in personnel injury or death.



WARNING



ETHER AUTOMATIC COLD START SYSTEM

Ether fuel is extremely flammable and toxic. DO NOT smoke and make sure you are in a well-ventilated area away from heat, open flames or sparks. Wear eye protection. Avoid contact with skin and eyes and avoid breathing ether fumes. If fluid enters or fumes irritate the eyes, wash immediately with large quantities of clean water for 15 minutes. Seek medical attention immediately if ether is inhaled or causes eye irritation. Failure to follow this warning may cause death or serious injury to personnel.



WARNING

FUEL HANDLING

- DO NOT perform fuel system checks, inspections or maintenance while smoking or near fire, flames or sparks. Fuel may ignite, causing damage to vehicle and injury or death to personnel.
- Wear fuel-resistant gloves when handling fuels and promptly wash exposed skin and change fuel-soaked clothing.
- If equipped with arctic heater, be sure to turn heater off during refueling.



WARNING

HAZARDOUS WASTE DISPOSAL

When servicing this vehicle, performing maintenance, or disposing of materials such as engine coolant, transmission fluid, lubricants, battery acids or batteries, consult your unit/local hazardous waste disposal center or safety office for local regulatory guidance. If further information is needed, please contact The Army Environmental Hotline at 1-800-872-3845.



WARNING

HEARING PROTECTION

Hearing protection is required when operating this vehicle or when working in close proximity to vehicle when it is running. Failure to wear hearing protection may result in hearing loss.



WARNING

HYDRAULIC FLUID HANDLING

Wear protective gloves when handling hydraulic fluids. If exposed to hydraulic fluid, promptly wash exposed skin and change hydraulic fluid-soaked clothing. Failure to follow this warning may result in injury to personnel.



WARNING
HYDRAULIC SYSTEM



- DO NOT disconnect or remove any hydraulic system line or fitting unless hydraulic system pressure has been relieved. Tighten all connections before applying pressure. Escaping hydraulic fluid under pressure can penetrate the skin, causing serious injury.
- Search for leaks with a piece of cardboard. Protect hands and body from high-pressure fluids. If an accident occurs, see a doctor immediately. Any fluid injected into the skin must be surgically removed within a few hours or gangrene may result.
- At operating temperature, hydraulic oil is hot. Allow hydraulic oil to cool before disconnecting any hydraulic lines. Failure to do so could result in injury.
- Hydraulic fluid is very slippery. Immediately wipe up any spills. Failure to follow this warning may result in injury to personnel.



WARNING
LIFTING HEAVY COMPONENTS



- Hydraulic jacks are intended only for lifting tractor, not for supporting vehicle to perform maintenance. DO NOT get under vehicle after it is raised unless it is properly supported with blocks or other suitable cribbing. Failure to observe this warning may result in death or injury to personnel.
- Use extreme caution when handling heavy parts. Provide adequate support and use assistance during procedure. Ensure that any lifting device used is in good condition and of suitable load capacity. Keep clear of heavy parts supported only by lifting device. Failure to follow this warning may result in death or injury to personnel.
- Improper use of lifting equipment and improper attachment of cables to vehicle can result in serious personnel injury and equipment damage. Observe all standard rules of safety.



WARNING
LUBRICATING OIL HANDLING

Wear protective gloves when handling oils. If exposed to lubricating oil, promptly wash exposed skin and change oil-soaked clothing. Failure to follow this warning may result in injury to personnel.



WARNING
NBC EXPOSURE



- If NBC exposure is suspected, personnel wearing protective equipment must handle all air cleaner media. Consult your NBC Officer or NBC NCO for appropriate handling or disposal procedures.
- NBC contaminated filters must be handled using adequate precautions (FM 21-40) and must be disposed of by trained personnel.



To order this NBC decal use:

National Stock Number (NSN) - 7690-01-114-3702

Part Number (PN) - 12296626

Commercial and Government Entity Code (CAGEC) - 19207



WARNING

PRESSURIZED COOLING SYSTEM



- DO NOT service cooling system unless engine has cooled to at least 120°F (50°C) as indicated on coolant temperature gauge. This is a pressurized cooling system and escaping steam or hot coolant will cause serious burns.
- Wear effective eye, glove, and skin protection when handling coolants. Failure to do so may cause injury.



WARNING

R-134A REFRIGERANT



- Liquid refrigerant, when exposed to air, quickly evaporates and will freeze skin or eye tissue. Use care to prevent refrigerant from touching your skin or eyes. Serious injury or blindness may result if you come in contact with refrigerant.
- Refrigerant R-134a air conditioning systems should not be pressure tested or leak tested with compressed air. Combustible mixtures of air and R-134a may form, resulting in a fire or explosion, which could cause personnel injury.



WARNING

SLAVE STARTING

- When slave starting tractor, use NATO slave cable that DOES NOT have loose or missing insulation.
- DO NOT proceed if suitable cable is not available.
- DO NOT use civilian-type jumper cables.

WARNING

YARD TRACTOR OPERATION

- The M878A2 Yard Tractor, without a trailer, is capable of making turns tighter than 90 degrees. When towing a trailer, attempting turns tighter than 90 degrees will cause interference between tractor and semitrailer. The point of interference is directly related to the position of the fifth wheel. The higher the fifth wheel, the more the turning radius is reduced. Failure to follow this warning could result in injury to personnel or damage to equipment.
- The M878A2 Yard Tractor has a solid mount rear axle suspension and handles differently than a tractor with a sprung suspension. When operating without a trailer, this difference is even more noticeable. Operators must become familiar with the handling of the yard tractor, during training and initial operations, to avoid the potential hazard of vehicle instability and loss of control. Failure to do so may result in serious injury or death to personnel or damage to equipment.

WARNING

WHEEL AND TIRE ASSEMBLIES

- Whenever wheel nuts require tightening or a wheel has been removed and replaced, wheel nuts must be tightened to the required torque. Failure to follow this warning may result in serious injury to personnel or damage to equipment.
- To avoid serious injury or death, NEVER attempt to inflate a tire that has been run flat or seriously under inflated. Break down tire and wheel assembly for inspection.

**UNIT, DIRECT SUPPORT, AND GENERAL SUPPORT
MAINTENANCE MANUAL**

FOR

**TRUCK, TRACTOR, YARD TYPE:
46,662 GVWR, DED, 4 X 2, M878A2
(NSN 2320-01-452-5579)**

TM 9-2320-312-24-2, dated 17 December 2003, is changed as follows:

1. File this change sheet in front of the publication for reference purposes.
2. New or changed material is indicated by a vertical bar adjacent to the material and/or by change designations at the bottom of the affected page.
3. Remove old pages and insert new pages as indicated below:

Remove Pages

c through h

Insert Pages

c through h

Approved for public release; distribution is unlimited.

By Order of the Secretary of the Army:

PETER J. SCHOOMAKER
General, United States Army
Chief of Staff

Official:

SANDRA R. RILEY
*Administrative Assistant to the
Secretary of the Army*
0510804

DISTRIBUTION: To be distributed in accordance with the initial distribution requirements for IDN: 381130, requirements for TM 9-2320-312-24-2.

LIST OF EFFECTIVE PAGES

Dates of issue for original manual and change pages are:

Original 17 December 2003
 Change 1 2 September 2005

TOTAL NUMBER OF PAGES IN THIS PUBLICATION IS 746 CONSISTING OF THE FOLLOWING:

Page No.	*Change No.
Cover	0
Blank	0
a and b	0
c	1
d	0
e through h	1
i/j (blank)	0
i through x	0
Fan Clutch (pages 3 through 9)	0
Schematic (page 10)	0
Engine Specifications (pages 1 through 31)	0
Index (page 32)	0
System Operation Testing and Adjusting (pages 1 through 105)	0
Index (pages 106 and 108)	0
Engine Troubleshooting (pages 1 through 429)	0
Index (pages 430 through 435)	0
Engine Disassembly and Assembly (pages 1 through 115)	0
Index (pages 116 through 119)	0
Schematics	0
DA Form 2028	0
Back Cover	0

* Zero in this column indicates an original page.

TECHNICAL MANUAL
TM 9-2320-312-24-2

HEADQUARTERS
DEPARTMENT OF THE ARMY
Washington, D.C., 17 December 2003

TECHNICAL MANUAL
UNIT, DIRECT SUPPORT, AND GENERAL SUPPORT
MAINTENANCE MANUAL

FOR

TRUCK, TRACTOR, YARD TYPE:
46,662 GVWR, DED, 4 X 2, M878A2
(NSN 2320-01-452-5579)

REPORTING ERRORS AND RECOMMENDING IMPROVEMENTS

You can help improve this publication. If you find any mistakes or if you know of a way to improve the procedures, please let us know. Submit your DA Form 2028 (*Recommended Changes to Equipment Technical Publications*), through the Internet, on the Army Electronic Product Support (AEPS) website. The Internet address is <http://aeps.ria.army.mil>. If you need a password, scroll down and click on "ACCESS REQUEST FORM". The DA Form 2028 is located in the ONLINE FORMS PROCESSING section of the AEPS. Fill out the form and click on SUBMIT. Using this form on the AEPS will enable us to respond quicker to your comments and better manage the DA Form 2028 program. You may also mail, fax or e-mail your letter, DA Form 2028 direct to: AMSTA-LC-LPIT/TECH PUBS, TACOM-RI, 1 Rock Island Arsenal, Rock Island, IL 61299-7630. The e-mail address is: TACOM-TECH-PUBS@ria.army.mil. The fax number is DSN 793-0726 or Commercial (309) 782-0726.

DISTRIBUTION STATEMENT A - Approved for public release; distribution is unlimited.

Table of Contents

Page
Number

VOLUME 2

Warning Summary a

How to Use This Manual vii

GROUP 020 ENGINE

Service, Troubleshooting, and Repair of 1090-0800 Fan Clutch

Installation and Service Guide: BorgWarner Cooling Systems Front Air Fan Drives

Preventive Maintenance 3

Fan Clutch Lining Maintenance 4

Troubleshooting Guide 5

Fan Clutch Service Parts and Repair 6

Rebuild Procedures 7

Fan and Fan Clutch Torque Specifications 9

Schematic 10

Caterpillar Specifications: 3126E Truck Engine

Specifications Section

Engine Design 4

Fuel Transfer Pump (Fuel Transfer Pump and High Pressure Oil Pump) 4

Fuel Filter Lines 5

Fuel Filter Base 5

Unit Injector 6

Valve Rocker Arms, Lifters, and Bridges 6

Valve Mechanism Cover 7

Cylinder Head Valves 7

Cylinder Head 9

Turbocharger 9

Air Inlet Elbow 10

Exhaust Manifold 10

Exhaust Elbow 11

Camshaft 11

Engine Oil Filter Base 12

Engine Oil Cooler Bypass Valve 13

Engine Oil Pump 13

Engine Oil Pan 14

Crankcase Breather 14

Water Temperature Regulator 14

Water Pump 15

Cylinder Block Cover Group 15

Caterpillar Specifications: 3126E Truck Engine - Con't

Specifications Section - Con't

Cylinder Block	16
Crankshaft.	17
Crankshaft Seals	17
Rear Seal Carrier (If Equipped)	18
Vibration Damper.	19
Connecting Rod Bearing Journal	19
Main Bearing Journal	19
Connecting Rod	19
Piston and Rings	20
Piston Cooling Jet.	22
Front Housing and Covers	22
Gear Group (Front).	24
Flywheel	25
Flywheel Housing.	25
Crankshaft Pulley	26
Belt Tension Chart	26
Belt Tensioner (If Equipped)	28
Belt Tightener	28
Fan Drive	28
Coolant Temperature Sensor	29
Engine Oil Pressure Sensor (If Equipped)	29
Engine Oil Temperature Sensor (If Equipped).	29
Boost Pressure Sensor	30
Atmospheric Pressure Sensor (If Equipped)	30
Inlet Air Temperature Sensor	30
Speed and Timing Sensor.	30
Air Inlet Heater.	31

Index Section

Index	32
-----------------	----

Caterpillar Systems Operation Testing and Adjusting: 3126E Truck Engine

Systems Operation Section

Engine Design	4
General Information	5
Glossary of Electronic Control Terms	4
Electronic Control System Components	11
Fuel System	15
Air Inlet and Exhaust System	44
Lubrication System.	50
Cooling System	52
Basic Engine	55
Electrical System	57

Caterpillar Systems Operation and Testing and Adjusting: 3126E Truck Engine - Con't

Testing and Adjusting Section

Fuel System	59
Air Inlet and Exhaust System	68
Lubrication System	82
Cooling System	87
Basic Engine	96
Electrical System	101

Index Section

Index	106
-----------------	-----

Caterpillar Troubleshooting: 3126E Truck Engine

Troubleshooting Section

Electronic Troubleshooting	5
Programming Parameters	27
Customer Specified Parameters	35
System Configuration Parameters	68
Troubleshooting without a Diagnostic Code	69
Troubleshooting with a Diagnostic Code	99
Diagnostic Functional Tests	139
Calibration Procedures	425

Index Section

Index	430
-----------------	-----

Caterpillar Disassembly and Assembly: 3126E Truck Engine

Disassembly and Assembly Section

Fuel Filter Base - Remove	5
Fuel Filter Base - Install	6
Fuel Transfer Pump - Remove	6
Fuel Transfer Pump - Install	7
Fuel Pressure Regulator - Remove and Install	8
Unit Injector - Remove	9
Unit Injector - Install	12
Unit Injector Sleeve - Remove	16
Unit Injector Sleeve - Install	17
Injection Actuation Pressure Control Valve - Remove	17
Injection Actuation Pressure Control Valve - Disassemble	18
Injection Actuation Pressure Control Valve - Assemble	18
Injection Actuation Pressure Control Valve - Install	19
Unit Injector Hydraulic Pump - Remove	19
Unit Injector Hydraulic Pump - Install	21
Turbocharger - Remove	23
Turbocharger - Install	24
Exhaust Manifold - Remove and Install	24

Caterpillar Disassembly and Assembly: 3126E Truck Engine - Con't

Disassembly and Assembly Section - Con't

Exhaust Particulate Filter - Disassemble	26
Exhaust Particulate Filter - Assemble	28
Air Inlet Heater - Remove and Install	29
Air Inlet Heater Solenoid - Remove and Install	30
Air Inlet Cover - Remove and Install	30
Inlet and Exhaust Valves - Remove and Install	31
Inlet and Exhaust Valve Guides - Remove and Install	32
Inlet and Exhaust Valve Seat Inserts - Remove and Install	34
Engine Oil Filter Base - Remove	35
Engine Oil Filter Base - Disassemble	36
Engine Oil Filter Base - Assemble	37
Engine Oil Filter Base - Install	37
Engine Oil Pump - Remove	38
Engine Oil Pump - Disassemble	38
Engine Oil Pump - Assemble	40
Engine Oil Pump - Install	41
Water Pump - Remove	42
Water Pump - Disassemble	43
Water Pump - Assemble	44
Water Pump - Install	45
Water Temperature Regulator - Remove and Install	46
Flywheel - Remove	47
Flywheel - Install	48
Crankshaft Rear Seal - Remove	49
Crankshaft Rear Seal - Install	49
Crankshaft Wear Sleeve (Rear) - Remove (If Equipped)	51
Crankshaft Wear Sleeve (Rear) - Install	51
Crankshaft Rear Seal Carrier - Remove and Install	52
Flywheel Housing - Remove and Install	53
Rear Power Take-Off (RPTO) - Disassemble	55
Rear Power Take-Off (RPTO) - Assemble	58
Vibration Damper and Pulley - Remove and Install	62
Crankshaft Front Seal - Remove	63
Crankshaft Front Seal - Install	63
Front Cover - Remove	64
Front Cover - Install	64
Housing (Front) - Remove	65
Housing (Front) - Install	66
Camshaft Idler Gear - Remove and Install	66
Valve Mechanism Cover - Remove and Install	68
Valve Mechanism Cover Base - Remove and Install	70
Rocker Shaft and Pushrod - Remove	71
Rocker Shaft - Disassemble	72
Rocker Shaft - Assemble	73
Rocker Shaft and Pushrod - Install	73
Cylinder Head - Remove	74
Cylinder Head - Install	75

Caterpillar Disassembly and Assembly: 3126E Truck Engine - Con't

Disassembly and Assembly Section - Con't

Lifter Group - Remove and Install	76
Camshaft - Remove	78
Camshaft - Install	79
Camshaft Gear - Remove and Install	80
Engine Oil Pan - Remove and Install	81
Piston Cooling Jets - Remove and Install	82
Pistons and Connecting Rods - Remove	83
Pistons and Connecting Rods - Disassemble	84
Pistons and Connecting Rods - Assemble	85
Pistons and Connecting Rods - Install	87
Crankshaft Main Bearings - Remove	89
Crankshaft Main Bearings - Install	90
Crankshaft - Remove	91
Crankshaft - Install	91
Crankshaft Gear - Remove and Install	93
Bearing Clearance - Check	94
Atmospheric Pressure Sensor - Remove and Install	95
Coolant Temperature Sensor - Remove and Install	95
Engine Oil Pressure Sensor - Remove and Install	96
Engine Oil Temperature Sensor - Remove and Install	97
Injection Actuation Pressure Sensor - Remove and Install	98
Speed/Timing Sensor - Remove and Install	99
Boost Pressure Sensor - Remove and Install	100
Inlet Air Temperature Sensor - Remove and Install	101
Idler Pulley - Remove	102
Idler Pulley - Disassemble	102
Idler Pulley - Assemble	103
Idler Pulley - Install	103
Belt Tensioner - Remove and Install	104
Belt Tightener - Remove	104
Belt Tightener - Disassemble	105
Belt Tightener - Assemble	105
Belt Tightener - Install	106
Fan Drive Mounting Group - Remove and Install	106
Fan Drive - Remove	108
Fan Drive - Install	108
Engine Control Module - Remove and Install	109
Alternator - Remove and Install	109
Electric Starting Motor - Remove and Install	110
Air Compressor - Remove and Install	111
Air Compressor Drive Gear - Remove	114
Air Compressor Drive Gear - Install	115

Index Section

Index	116
-----------------	-----

Caterpillar Schematic: 3126E Truck Engine Electrical System

This Page Intentionally Left Blank.

HOW TO USE THIS MANUAL

NOTE

If at any time you are unsure how to use this manual or you cannot locate the information you need, notify your supervisor.

INTRODUCTION

1. This manual is designed to help you perform Unit, Direct Support, and General Support Maintenance on the M878A2 Yard Tractor.
2. The *Repair Parts and Special Tools List (RPSTL)*, TM 9-2320-312-24P, is to be used in conjunction with this manual, to locate and obtain the repair parts and special tools needed to maintain this equipment.
3. This manual consists of three volumes: Volume 1 contains maintenance and troubleshooting for yard tractor components NOT covered in the Commercial Service Manuals. Volumes 2 and 3 are a compilation of Commercial off-the-Shelf (COTS) Service Manuals.
4. A *Table of Contents* at the front of Volume 1 lists the contents of all volumes of this publication. Each volume also contains a *Table of Contents* for that particular volume.
5. Volume 1 is written in work package format, in accordance with MIL-STD-40051A:
 - a. Chapters divide the manual into major categories of information (e.g. *Introductory Information with Theory of Operation, Troubleshooting Procedures, Unit Maintenance, Direct Support Maintenance, General Support Maintenance, and Supporting Information*).
 - b. Each Chapter is divided into work packages, which are identified by a 6-digit number (e.g. 0001 00, 0002 00, etc.) located on the upper right-hand corner of each page. The work package page number (e.g. 0001 00-1, 0001 00-2, etc.) is located centered at the bottom of each page.
 - c. If a Change Package is issued to this manual, added work packages use the 5th and 6th digits of their number to indicate new material. For instance, work packages inserted between WP 0001 00 and WP 0002 00 are numbered WP 0001 01, WP 0001 02, etc.
6. Volumes 2 and 3 are provided in commercial format.
7. Scan through all volumes of this manual to become familiar with their organization and contents before attempting to maintain the equipment.

ORGANIZATION OF MATERIAL

1. Maintenance procedures in each volume are sequenced in accordance with the following major assembly groups, as outlined in the Maintenance Allocation Chart (MAC) in Volume 1:
 - a. Group 020—engine
 - b. Group 040—fuel
 - c. Group 050—exhaust
 - d. Group 060—cooling
 - e. Group 070—transmission
 - f. Group 080—front axle (includes front axle steering components and front service brakes)
 - g. Group 090—rear axle (includes rear service brakes)
 - h. Group 110—steering
 - i. Group 115—frame
 - j. Group 120—propshaft
 - k. Group 140—cab and sheet metal
 - l. Group 150—air piping and brake

ORGANIZATION OF MATERIAL - CONTINUED

- m. Group 160—miscellaneous
 - n. Group 170—electrical
 - o. Group 180—power take-off (PTO)
 - p. Group 190—oil piping (all fluid lines except air)
2. In the Commercial Service Manuals, troubleshooting is located in the same section as the maintenance procedures for that assembly group. For instance, engine troubleshooting is located within Group 020; transmission troubleshooting is located within Group 070.
 3. In the work package-formatted material, troubleshooting for ALL assembly group components is located in work package 0006 00. However, the Troubleshooting Symptom Index in WP 0005 00 contains a listing of ALL troubleshooting procedures, to include those contained in the Commercial Service Manuals.

CONTENTS OF VOLUME I (WORK PACKAGE-FORMATTED MANUAL)

1. A *Warning Summary* is located at the beginning of this volume. Become familiar with these warnings before performing troubleshooting or maintenance on the vehicle.
2. A *Table of Contents*, located in the front of this volume, lists all chapters and work packages in the publication, as well as the contents of Volumes 2 and 3.
 - a. The *Table of Contents* also provides *Reporting Errors and Recommending Improvements* information and DA Form 2028 addresses, for the submittal of corrections to this manual.
 - b. If you cannot find what you are looking for in the *Table of Contents*, refer to the alphabetical *Index* at the back of the manual.
3. Chapter 1, *Introductory Information with Theory of Information*, provides general information on the manual and the equipment.
4. Chapter 2, *Troubleshooting Procedures*, contains troubleshooting.
5. Chapter 3 covers all *Unit Maintenance*.
6. Chapter 4 covers all *Direct Support Maintenance*.
7. Chapter 5 covers all *General Support Maintenance*.
8. Chapter 6 covers *Supporting Information: References, Maintenance Allocation Chart (MAC) Introduction, Maintenance Allocation Chart (MAC), Expendable and Durable Items List, and Tool Identification List*.
9. There are electrical system *Foldouts* at the back of Volume 1.

CONTENTS OF VOLUMES 2 AND 3 (COMMERCIAL SERVICE MANUALS)

1. Volume 2 contains Group 020—engine.
2. Volume 3 contains:
 - a. Group 070—transmission.
 - b. Group 080—front axle
 - c. Group 090—rear axle
 - d. Group 110—steering
 - e. Group 120—propshaft
 - f. Group 140—cab and sheet metal
 - g. Group 150—air piping and brake
 - h. Group 160—miscellaneous

FEATURES OF VOLUME I (WORK PACKAGE-FORMATTED MANUAL)

1. Because the major assembly groupings used in this manual do not correspond to military function group codes (FGC) and are unfamiliar to the soldier, maintenance tasks in Volume I include in their initial setups the following information:
 - a. MAC Reference (e.g., MAC Group 160)
 - b. RPSTL Reference (e.g., RPSTL Group 160, Figure 003)

This information will assist the user to locate appropriate MAC guidance and repair parts for the component being maintained.

2. WARNINGS, CAUTIONS, NOTES, subject headings, and other important information are highlighted in **BOLD** print as a visual aid.

WARNING

A WARNING indicates a hazard that may result in death or serious injury.

CAUTION

A CAUTION is a reminder of safety practices or directs attention to usage practices that may cause damage to equipment.

NOTE

A NOTE is a statement containing information that will make the procedures easier to perform.

3. Statements and words of particular interest may be printed in CAPITAL LETTERS to create emphasis.
4. Within a procedural step, reference may be made to another work package in this volume of the manual or to another volume of this manual or another manual. These references indicate where you should look for more complete information.
 - a. If you are told: “Fill hydraulic reservoir (WP 0129 00)”, go to work package 0129 00 in Volume 1 of this manual for instructions on filling the hydraulic reservoir.
 - b. If you are told: “Raise fifth wheel (TM 9-2320-312-10)”, go to TM 9-2320-312-10 for complete instructions on raising the fifth wheel. Use the *Table of Contents* or alphabetical *Index* in TM 9-2320-312-10 to find the procedure.
 - c. If you are told “Repair transmission torque converter (Group 070 Commercial Service Manuals)”, go to Group 070 in the Commercial Service Manuals (Volume 3) to find the procedure.
5. Illustrations are placed after, and as close to, the procedural steps to which they apply. Callouts placed on the art may be text or numbers, or both.
6. Numbers located at the lower right corner of the art (e.g. 376-001, 376-002, etc.) are art control numbers and are used for tracking purposes. Disregard these numbers.
7. Dasher leader lines used in illustrations indicate that called-out items are not visible in the view depicted (i.e. they are located within or behind the structure). In Lubrication Charts (WP 0008 00, *Unit PMCS Introduction*) and in *Unit PMCS* (WP 0009 00), dashed leader lines indicate a lubrication that is required on both sides of the equipment.
8. Technical instructions include metric units as well as standard units. For your reference, a *Metric Conversion Chart* is located on the inside back cover of the manual.

This Page Intentionally Left Blank.

**SERVICE, TROUBLESHOOTING, AND REPAIR OF
1090-0800-01 FAN CLUTCH**

This Page Intentionally Left Blank.

INSTALLATION AND SERVICE GUIDE Front Air Fan Drives



BorgWarner
Cooling Systems

On behalf of the entire BorgWarner Cooling Systems organization, we wish to thank you for purchasing a BorgWarner Fan Clutch. We sincerely believe this product to be the highest quality, most dependable Fan Clutch on the market and we are confident that it will provide you with the high performance and

reliable service that you desire. This installation and service guide contains the information you will need to properly install and maintain your fan clutch for maximum life and dependable service. We urge you to thoroughly familiarize yourself with the contents of this guide and preserve it for future reference.

Table of Contents

Fan Drive Assemblies: A Clutch And A Hub Combined Under A 1093 Part Number . . .	2-4
Fan Clutches - Description And Availability	5
Fan Clutches - Identification And Replacements	5
Fan Clutch - Identification And Specifications	6
Fan Hubs - Identification, Service Parts And Repair	6-8
Idler Pulleys - Identification, Service Parts And Repair	8
Installation - All Clutches.	9
Installation - Crankshaft And Isolation Mount Clutches	10
Preventive Maintenance	11-12
Troubleshooting	13
Fan Clutch Removal	13
Fan Clutch 1090-07050 Service Parts And Repair	14-17
Fan Clutch 1090-08000 Service Parts And Repair	17-20
Fan And Fan Clutch Torque Specifications	20
Control System Requirements.	20-22
Emergency Lockup Procedure	23

Fan Drive Assemblies

A Clutch And A Hub Combined Under A 1093 Part Number

The front air fan drive assembly shown here consists of a clutch (1090 part number), a hub (1077 part number) and in most cases, an adaptor kit (1096 part number).

REPLACEMENT CLUTCHES: The 1090-05000 and -6000 series clutches are obsolete and service parts are no longer supplied. To replace one of them, look up your 1093 drive assembly in the chart on pages 2-4, determine which clutch was used and select a new one from the table on page 5.

REPLACEMENT HUBS: None of the hubs used in front air 1093 fan drive assemblies are in production. The tapered roller bearing type hub was the most common, and the bearing kits for it are still available.

"1093" SERIES - FAN DRIVE ASSEMBLY (FRONT AIR)

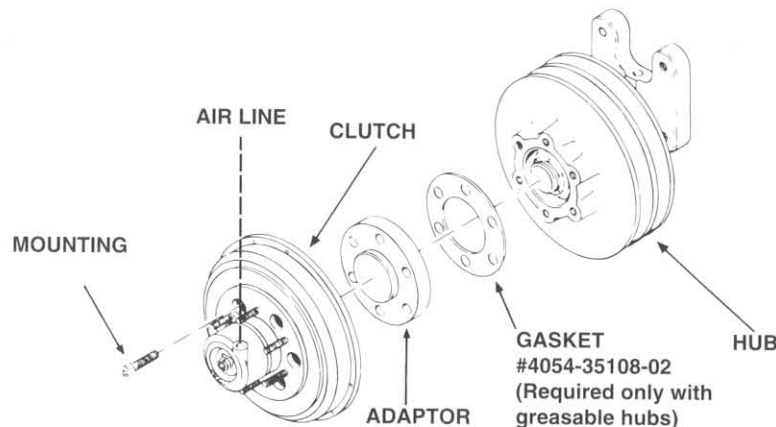

This Page Intentionally Left Blank.

Preventive Maintenance

FAN HUBS: Grease at every PM using a high quality, high temperature bearing grease with EP additives such as AeroShell 5 or Chevron SRI-2. DO NOT USE ORDINARY CHASSIS GREASE - IT WILL MELT UNDER THE TEMPERATURES GENERATED BY FAN DRIVES.

FAN CLUTCHES: (Every PM)

What to do	How to do it
Check operation	Turn on key or jumper control system so that 120 psi air gets to clutch. It should disengage and turn freely. Turn off key. Clutch should lock up and be difficult to turn by hand.
Check for air leaks and cylinder problems.	Turn on key or jumper control system so that 120 psi air gets to clutch. Feel front of clutch (cylinder) for air leaks. Turn cylinder back and forth to limit of air line. It should not bind or catch. (Remove clutch to repair if either problem is found.) Check that air line has some tension and cannot get into fan. (See installation instructions.)
Lining wear check	1090-07050. When clutch has no air pressure, fan should be very difficult to turn. If it seems easy, remove clutch and replace lining or rebuild as described in repair section. 1090-08000. See use of lining wear gauge, on page 12.

Fan Clutch Lining Maintenance

FAN CLUTCH LINING MAINTENANCE

It is very important to check fan clutch lining condition on a regular basis:

CLUTCH LINING MAINTENANCE	
FIRST CHECK:	100,000 miles (160,930 km)
SUBSEQUENT CHECKS:	Every 50,000 miles (80,465 km)

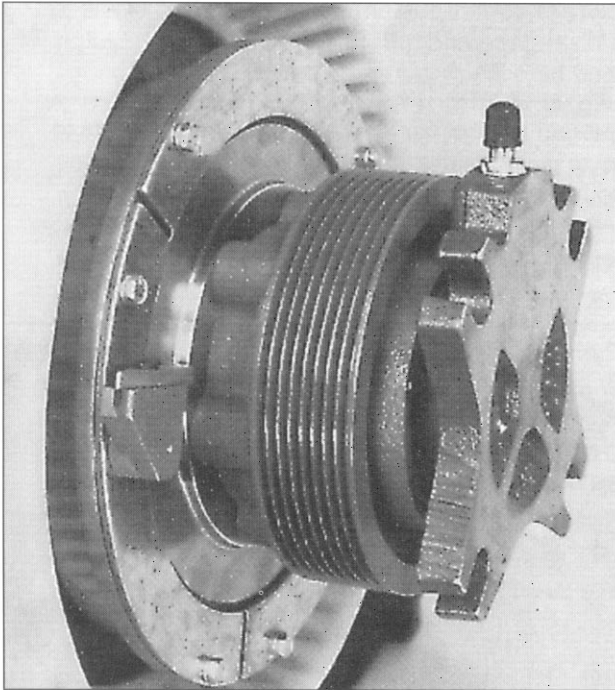

Use the lining wear tool for estimating the amount of clutch lining wear.

1. Apply 90 - 120 psi (6.2 - 8.2 bar) air pressure to the fan clutch (disengage).
2. Place the lining wear tool on a retaining plate on the back of the fan clutch. Press the lever against the rear face of the fan clutch shaft assembly.

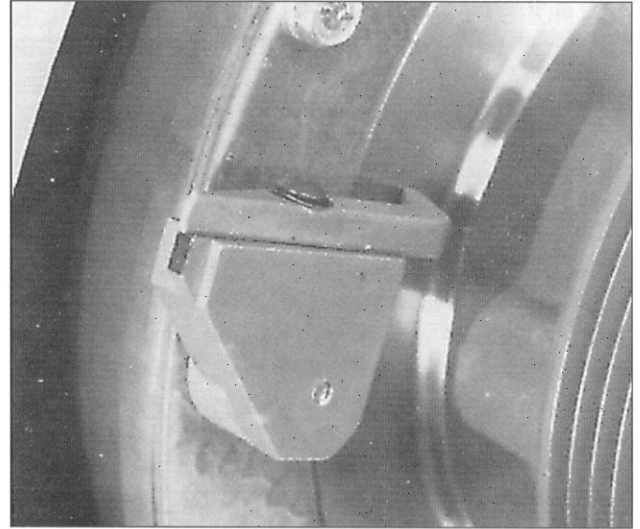
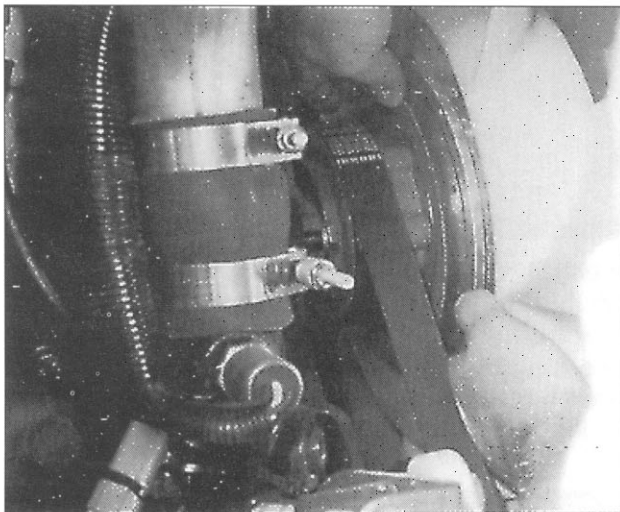

Note the position of the lever in relation to the step on the lining wear tool.

3. Remove the air pressure from the fan clutch (engage).

If the lever travels the full width of the step, the lining needs to be replaced. When the lining is new the lever will travel approximately half the width of the step. The lever may or may not line up with the rear of the step at the start of the check. If not, estimate the amount of travel.

NOTE: RAPID LINING WEAR INDICATES A PROBLEM IN THE FAN DRIVE CONTROL SYSTEM OR AN AIR LEAK. SEE PAGES 21 & 22 FOR CONTROL SYSTEM SPECIFICATIONS AND TYPES. CALL BORGWARNER COOLING SYSTEMS TECH SERVICE FOR TROUBLESHOOTING ASSISTANCE, 800-927-7811.

REPLACING THE LINING (1090-08000 ONLY)

THE BORGWARNER FAN DRIVE IS EASY TO RELINE WITHOUT REMOVING IT FROM THE VEHICLE.

TOOLS & PARTS REQUIRED

Inch pound or Newton Meter torque wrench
1/4" drive ratchet
1/4" drive 5/16" socket
Clutch lining kit, 1033-08250-01

CAUTION: THE FAN CLUTCH MUST HAVE AIR PRESSURE DURING THIS PROCEDURE (90-120 psi; 6.2-8.2 bar)

Remove the six lining plate screws and the three lining plates. Remove the old lining and install the new lining. Replace the plates and screws and torque screws to 30 pounds inch (3.4 Newton Meters).

Troubleshooting Guide

Problem	Cause	Solution	Reference
Front air leaks	Dirty or worn seals	Rebuild or replace clutch.	See Page 5, 14-20
Air leaking in the clutch	Internal "O" ring damaged	Rebuild or replace clutch.	See Page 5, 14-20
Clutch will not engage when air pressure is removed	Worn out lining or Dust seal hanging up on cylinder wall	Rebuild clutch.	See Page 14-20
Lining worn	Over cycling caused by bad temperature or A/C switch	1090-08000 ONLY: Supply air pressure to clutch and remove and replace lining. Clean out back of clutch. 1090-07050 ONLY: Remove to repair Both clutches: Replace switches if necessary.	See Page 12 See Page 14-17 See Page 20-22
	Air line leaks	Check for air leaks in line and fittings. Replace lining.	See Page 12, 14-17
	Stationary vehicle or PTO over cycling the fan clutch	Install an override device. Replace lining.	See Page 20-22 See Page 12, 14-17
	Insufficient air pressure or debris in solenoid valve restricting air flow.	Air pressure 90-150 PSI check air supply. Replace lining and solenoid valve if necessary.	See Page 12, 14-17, 20-22
Clutch will not disengage	Over cycling caused by bad temperature or A/C switch or clutch lining rusted to the shaft.	1090-08000 ONLY: Supply air pressure to clutch and remove and replace lining. Clean out back of clutch. 1090-07050 ONLY: Remove to repair Both clutches: Replace switches if necessary.	See Page 12 See Page 16-17 See Page 20-22

Fan Clutch Removal

Pressurize clutch to disengage so that holes can be lined up. If clutch will not disengage, put fan back on studs and manually rotate clutch to line up holes.

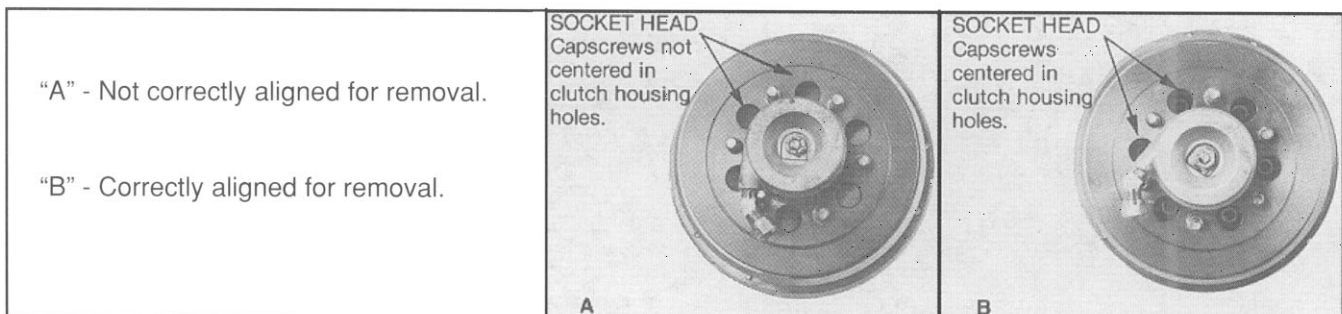

Rebuild Procedures, Continued

- B. Place new tab washer into cylinder cavity. Align tab and keyway in piston rod, and push cylinder onto clutch. Start the nut.
- C. SLOWLY compress clutch until it disengages and can be turned. Restrain cylinder from turning, and torque the cylinder nut to 84 lbs-inch.

- 8. Pressurize clutch to 90 psi several times to test free movement and to center wear plate and lining in housing. While clutch is pressurized, torque lining plate screws and nuts to 30 lbs-inch. Make sure you have no air leaks. While clutch is pressurized, line up access holes in front with bolt holes in rear.

Fan Clutch Service Parts And Repair

1090-08000 REPAIR

I. Tools Required:

- A. Two carriage bolts with wing nuts and washers. These must be about two inches longer than the distance through the holes in the fan clutch, as shown. Install them and compress the clutch slightly while loosening the cylinder nut (item 2 in the blow-up) and the lining plate screws, (item 18 in the blow-up). Then, back them off evenly to allow the clutch halves to separate. During re-assembly, tighten the carriage bolts evenly to compress the clutch before you install and tighten the cylinder nut and the lining plate screws.

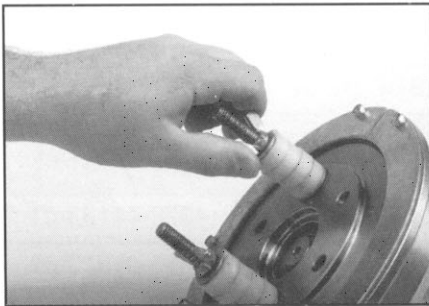

- B. Inch pound torque wrench with 5/16 and 1/2 inch sockets, 5/16 inch box wrench
- C. Loc Tite® 640
- D. Internal snap ring pliers

II. Parts Required

Description	Part Number
Repair Kit	1033-05435-02
Cylinder Assembly	4043-41130-01
Piston Rod Assembly	4079-41133-01

III. CYLINDER INSTALLATION

Use the picture below to help you correctly line up the tab washer (item 3 in the blow-up) with the cylinder during assembly.

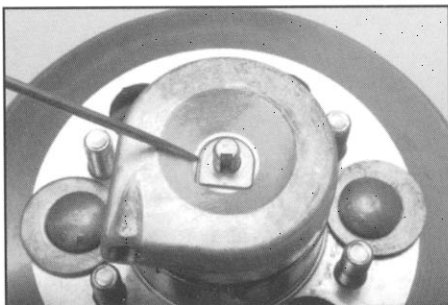

Rebuild Procedures

8000 SERIES "K-22" FRONT AIR 1090-08000-XX

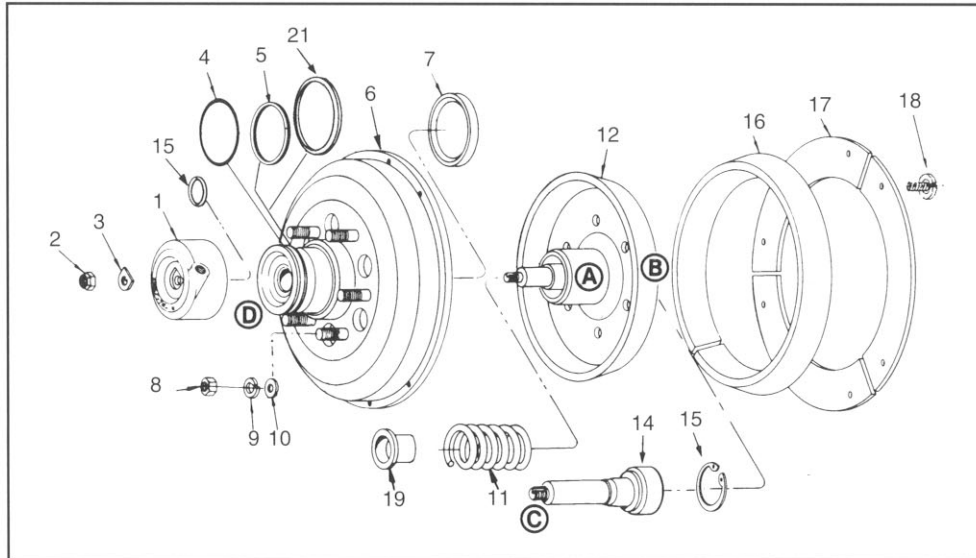

KEY	DESCRIPTION	PART NUMBERS
1	Cylinder Assy.	4043-41130-01
2	Cylinder Nut	3029-01371-01
3	Tab Washer	3058-01264-02
4	"O" Ring	9002-00491-68
5	Dust Seal "O" Ring	3018-01703-01
6	Housing Assy.	4040-41131-01 (-01, -02 & -05) 4040-41131-02 (-03 & -04)
7	Grease Seal	3018-01507-01
8	Fan Nut	3030-00364-01
9	Lock Washer	3059-00870-06
10	Flat Washer	3058-00843-07
11	Spring	4088-40615-01
12	Shaft Assy.	4079-41132-01 (-01 & -03) 4079-41132-02 (-02 Only) 4079-41132-04 (-04 Only) 4079-41132-05 (-05 Only)

KEY	DESCRIPTION	PART NUMBERS
13	"O" Ring	1 of 9002-00741-58
14	Piston Rod Assy.	4079-41133-01
15	Snap Ring	3038-01510-01
16	1 Pc. Lining	4026-36900-01
17	Retaining Plate(s)	3 of 4073-38444-01
18	Screw	3042-01684-01
19	Spring End Cap	4001-40690-01
20	Spring Carrier*	4001-40691-01
21	Dust Seal	3018-01702-01
	Grease Packet	2035-01353-01
	REPAIR KITS (1)	1033-05435-02

NOTE: (1) Items listed in blue screened rows are included in the repair kits.

* Included in Piston Rod Assembly Item #14.

Rebuild Procedures, Continued

1. Compress clutch about 1/16 inch. Remove lining plate screws, lining plates, and lining. Discard lining and screws.
 2. Remove the 1/2 inch nut from the cylinder. Release pressure from clutch so that it comes all the way up.
 3. Remove cylinder and cylinder tab washer and discard. Separate the shaft assembly (inner part) from the bearing housing (outer part). Remove front spring cap and spring. Discard spring. Inspect front of spring cap for signs of rubbing (it will be shiny). If found, stop and replace fan clutch.
 4. Inspect needle bearing inner race on shaft (A in picture). It may be discolored and streaked, but as long as you can feel no damage with a fingernail, it's OK. It may be cleaned up with a Scotch Brite pad to make inspection easier. If damaged, discard clutch. Inspect the fan studs on the bearing housing (outer part). If any are loose or missing, discard clutch. If any are damaged and cannot be repaired with a thread die, discard clutch. Inspect piston bearing by turning piston (brass). If bearing feels rough or spins freely, indicating no grease left, discard clutch. If needle bearing inner race, studs and piston are OK, proceed with rebuild.
 5. Bearing Housing Service
 - A. Remove o-ring from piston and discard. Remove dust seal from front groove of bearing housing. It may be the steel type, which has to be spiraled out like a piston ring. It may be the Teflon type, which is cut and comes out easily. It may be the two piece, o-ring and square cut seal type, which are removed one at a time. Discard the dust seal.
 - B. Pry out the grease seal with a very large screwdriver. Use a rag wet with Brake Clean to thoroughly wash needle bearings and bearing housing. Do not let Brake Clean get into piston bearing. **DO NOT USE SAFETY SOLVENT.**
 - C. Using specified grease, lubricate the two piece dust seal. (Black o-ring and blue square-cut seal.) Being careful not to stretch them, install first the o-ring into the front groove on the stud side of the bearing housing, then the blue seal on top of it. Make sure the blue seal sits down in the groove squarely and does not get rolled over. (NOTE: It will be necessary to first, work each piece of the seal into the piston (brass) groove, then out into the second groove. Blue Seal may be warmed with a hair dryer to ease installation.)
 - D. Use a flat plate to press the grease seal in, lip down. Press until flush with edge of hole.
 - E. Liberally lubricate the piston o-ring, the blue dust seal and the nose of the clutch where they are located with the specified grease. Apply grease to the needle bearings, and pack the groove in front of the needle bearings (down in the bottom near the snap ring) and the groove between the needle bearings and the seal. Then, take the cleaned up shaft (inner part) and push it into the housing. Turn it a few times to work the grease into the needles. Remove it and wipe off any grease that comes out with it on the front. Do this a couple times until no more excess grease comes out. However, if no excess grease came out, you didn't have enough in there to start with. The idea is to end up with a layer of grease from front to rear, even with the needles, and with plenty of grease worked in behind the needles, but no more than that.
 - F. Use Brake Clean to clean any grease or greasy fingerprints from inside of bearing housing where lining touches. Also, make sure no grease is on the outside of the grease seal where it could get slung into the lining.
 - G. Set bearing housing aside.
6. Shaft assembly service
 - A. Remove snap ring from piston rod bearing. Press piston rod out of shaft. If piston rod comes out and bearing stays in, use a drift to push the bearing out the back. Discard old piston rod and bearing.
 - B. Wash shaft and lining plate with Brake Clean and dry. Use crocus cloth or sandpaper or a Scotch Brite pad on a grinder to break the glaze on the shaft where the lining touches (B in the picture), and on the plates where the lining touches. Use **ONLY** a Scotch Brite pad by hand to clean up the needle bearing inner race on the shaft. Rewash after using sandpaper or crocus cloth.
 - C. Place two drops of LocTite® 640 on the outer race of the piston rod bearing and spread it around with your finger. Use a socket to press the piston rod in. (CAUTION: Socket must contact only outer race of bearing.) Make sure there is enough room for the piston rod to go all the way in without the other end hitting something. Place snap ring in groove, sharp edge up.

Rebuild Procedures, Continued

- D. Place new rear spring cap (small one) onto the piston rod. Place new spring on piston rod. Liberally lubricate inside rear of front spring cap and then place it on the piston rod. Use Brake Clean to remove any grease or fingerprints that may be on the shaft where the lining touches.
7. Final Assembly
- A. Compress clutch SLOWLY while pushing down on lining. When lining gets flush with outer edge of clutch, STOP. Install lining plates, sharp edge down. Tighten screws to 30 lbs-inch.
 - B. Use grease to hold small o-ring in place on shoulder on rear inside of cylinder. Lubricate the rest of the shoulder in front of the o-ring. Place new tab washer into cylinder cavity. Align tab and keyway in piston rod, and push cylinder onto clutch. Start the nut.
 - C. Restrain cylinder from turning and torque the cylinder nut to 84 lbs-inch. Turn cylinder. It may have a slight gritty feel due to the additives in the grease, but if it feels real notchy, or turns hard, you most likely lost the small o-ring. Disassemble and correct.
 - 8. Pressurize clutch to 90 psi several times to test free movement. Make sure you have no air leaks. While clutch is disengaged, make sure access holes in front are aligned with bolt holes in back.

Fan And Fan Clutch Torque Specifications

TORQUE SPECS	
Clutch to Hub	45 lbs.-ft. (61 Newton Meters)
Fan to Clutch	26 lbs.-ft. (35.3 Newton Meters)
Front Piston Nut	84 lbs.-in. (9.5 Newton Meters)
Lining Plate Screws	30 lbs.-in. (3.4 Newton Meters)

Control System Requirements

- A. As a minimum, control systems must be thermal switches controlling solenoid valves. Mechanical thermal valves such as the old SHUTTERSTAT[®] are NOT permitted.
- B. Air conditioning override pressure switches must have a built in hysteresis of 50 psi (3.4 bar) minimum.
- C. If the vehicle is used in any kind of stationary operation involving a PTO or turbo unloader, there MUST be a provision in the control system to automatically lock the fan clutch ON whenever the PTO or unloader is being operated. Failure to provide this will void all warranties.
- D. If the vehicle is a sleeper cab and the engine is fast idled with the AC on, then a timed AC override circuit MUST be provided so that the fan clutch will not be over cycled. (The Medallion TTM[®] system is an example of a timed control system.)
- E. The preferred system is engine ECM Control, as shown in figure 4 on page 22. Contact the engine distributor for assistance.

Figure 1 Normally Closed Fan Clutch Control Circuit:

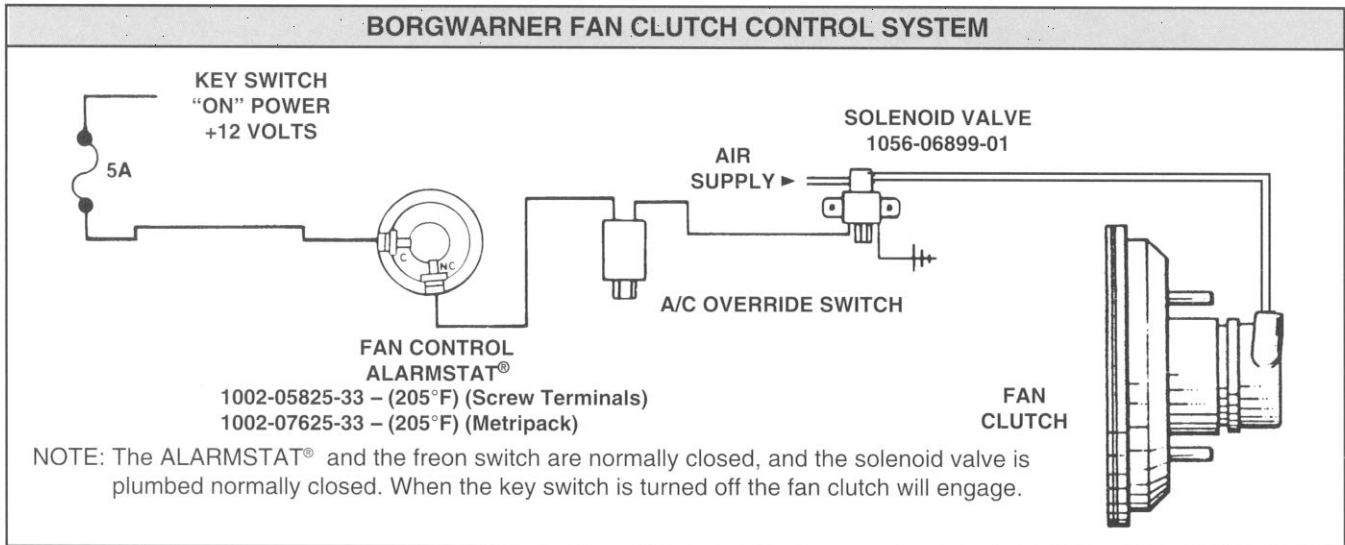
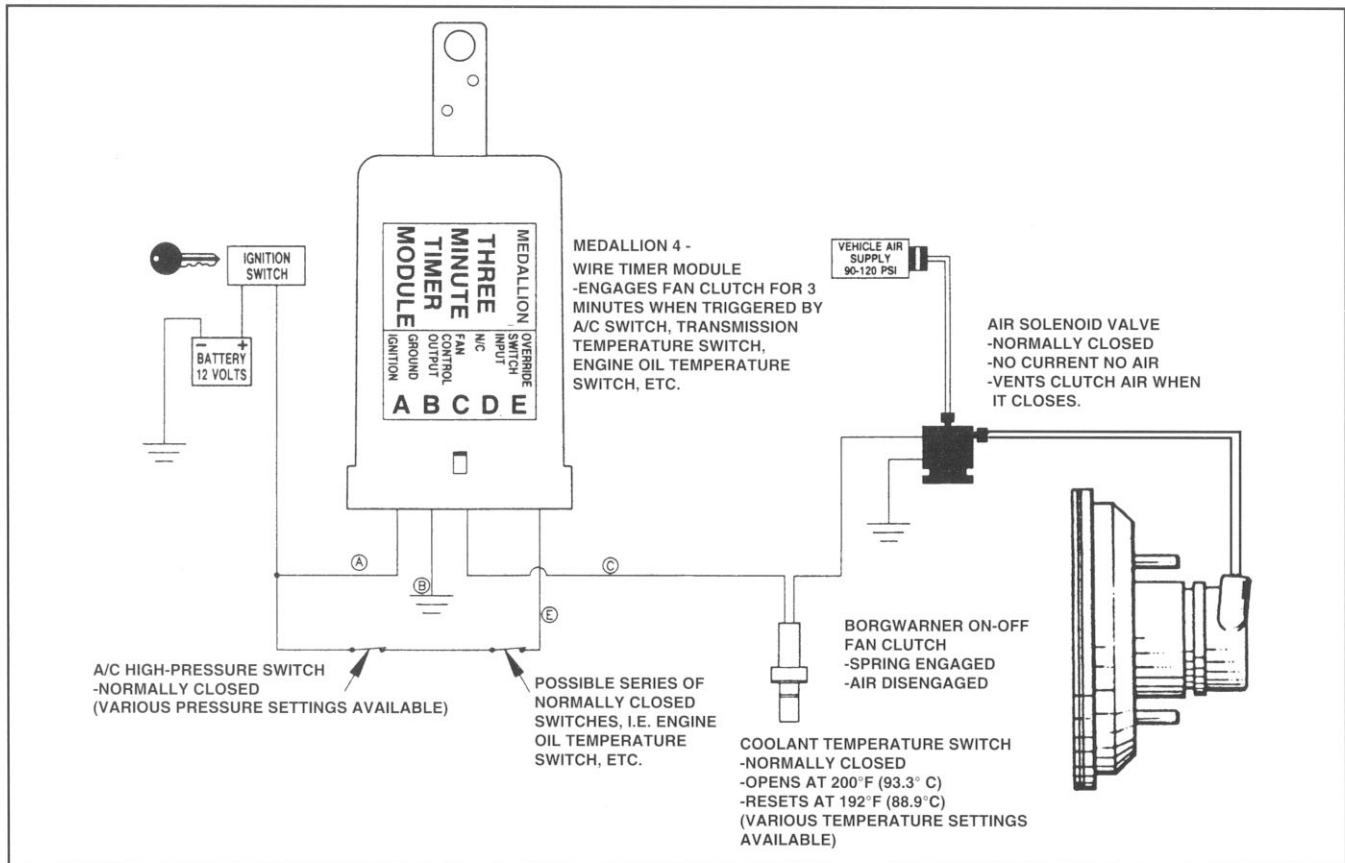

Figure 2 Normally Closed System With 3-Minute Timer: (Used on Ford Trucks)



Specifications

3126E Truck Engine

LEF1-Up (Engine)



Important Safety Information

Most accidents that involve product operation, maintenance and repair are caused by failure to observe basic safety rules or precautions. An accident can often be avoided by recognizing potentially hazardous situations before an accident occurs. A person must be alert to potential hazards. This person should also have the necessary training, skills and tools to perform these functions properly.

Improper operation, lubrication, maintenance or repair of this product can be dangerous and could result in injury or death.

Do not operate or perform any lubrication, maintenance or repair on this product, until you have read and understood the operation, lubrication, maintenance and repair information.

Safety precautions and warnings are provided in this manual and on the product. If these hazard warnings are not heeded, bodily injury or death could occur to you or to other persons.

The hazards are identified by the "Safety Alert Symbol" and followed by a "Signal Word" such as "DANGER", "WARNING" or "CAUTION". The Safety Alert "WARNING" label is shown below.



The meaning of this safety alert symbol is as follows:

Attention! Become Alert! Your Safety is Involved.

The message that appears under the warning explains the hazard and can be either written or pictorially presented.

Operations that may cause product damage are identified by "NOTICE" labels on the product and in this publication.

Caterpillar cannot anticipate every possible circumstance that might involve a potential hazard. The warnings in this publication and on the product are, therefore, not all inclusive. If a tool, procedure, work method or operating technique that is not specifically recommended by Caterpillar is used, you must satisfy yourself that it is safe for you and for others. You should also ensure that the product will not be damaged or be made unsafe by the operation, lubrication, maintenance or repair procedures that you choose.

The information, specifications, and illustrations in this publication are on the basis of information that was available at the time that the publication was written. The specifications, torques, pressures, measurements, adjustments, illustrations, and other items can change at any time. These changes can affect the service that is given to the product. Obtain the complete and most current information before you start any job. Caterpillar dealers have the most current information available.



When replacement parts are required for this product Caterpillar recommends using Caterpillar replacement parts or parts with equivalent specifications including, but not limited to, physical dimensions, type, strength and material.

Failure to heed this warning can lead to premature failures, product damage, personal injury or death.

Table of Contents

Specifications Section

Engine Design	4
Fuel Transfer Pump (Fuel Transfer Pump and High Pressure Oil Pump)	4
Fuel Filter Lines	5
Fuel Filter Base	5
Unit Injector	6
Valve Rocker Arms, Lifters, and Bridges	6
Valve Mechanism Cover	7
Cylinder Head Valves	7
Cylinder Head	9
Turbocharger	9
Air Inlet Elbow	10
Exhaust Manifold	10
Exhaust Elbow	11
Camshaft	11
Engine Oil Filter Base	12
Engine Oil Cooler Bypass Valve	13
Engine Oil Pump	13
Engine Oil Pan	14
Crankcase Breather	14
Water Temperature Regulator	14
Water Pump	15
Cylinder Block Cover Group	15
Cylinder Block	16
Crankshaft	17
Crankshaft Seals	17
Rear Seal Carrier (If Equipped)	18
Vibration Damper	19
Connecting Rod Bearing Journal	19
Main Bearing Journal	19
Connecting Rod	19
Piston and Rings	20
Piston Cooling Jet	22
Front Housing and Covers	22
Gear Group (Front)	24
Flywheel	25
Flywheel Housing	25
Crankshaft Pulley	26
Belt Tension Chart	26
Belt Tensioner (If Equipped)	28
Belt Tightener	28
Fan Drive	28
Coolant Temperature Sensor	29
Engine Oil Pressure Sensor (If Equipped)	29
Engine Oil Temperature Sensor (If Equipped)	29
Boost Pressure Sensor	30
Atmospheric Pressure Sensor (If Equipped)	30
Inlet Air Temperature Sensor	30
Speed and Timing Sensor	30
Air Inlet Heater	31

Index Section

Index	32
-------------	----

Specifications Section

i01147139

Engine Design

i01146230

SMCS Code: 1201

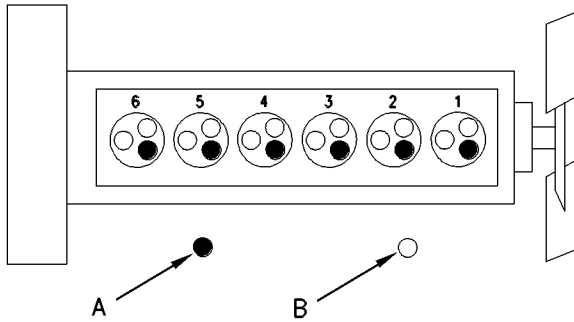

Illustration 1 g00290846

Cylinder And Valve Location

- (A) Exhaust valve.
- (B) Inlet valve.

Bore	110 mm (4.3 inch)
Stroke	127 mm (5.0 inch)
Displacement	7.25 L (442 in ³)
Number of cylinders	6
Cylinder arrangement	In-line
Valves per cylinder	3

In order to check the engine valve lash setting, the engine must be cold and the engine must be stopped. Engine valve lash settings

Inlet	0.38 mm (0.015 inch)
Exhaust	0.64 mm (0.025 inch)

Type of combustion Direct Injection

Firing Order 1 - 5 - 3 - 6 - 2 - 4

The crankshaft rotation is viewed from the flywheel end of the engine. Crankshaft rotation counterclockwise

Note: The front end of the engine is opposite of the flywheel end of the engine. The left side of the engine and the right side of the engine are viewed from the flywheel end of the engine. The number one cylinder is the front cylinder.

Fuel Transfer Pump (Fuel Transfer Pump and High Pressure Oil Pump)

SMCS Code: 1256

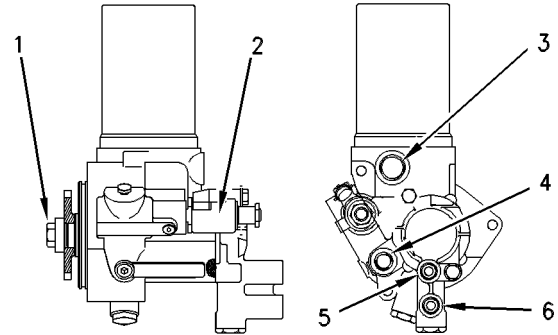

Illustration 2 g00608597

- (1) Tighten the bolt to the following torque. 110 ± 14 N·m (80 ± 10 lb ft)
- (2) Injection actuation pressure control valve (IAPCV)
- (3) Tighten the inlet of the oil pump to the following torque. 26 ± 3 N·m (19 ± 2 lb ft)
- (4) Tighten the outlet of the oil pump to the following torque. 23 ± 2 N·m (17 ± 1 lb ft)
- (5) Tighten the outlet of the fuel pump to the following torque. 18 ± 2 N·m (13 ± 1 lb ft)
- (6) Tighten the inlet of the fuel pump to the following torque. 18 ± 2 N·m (13 ± 1 lb ft)

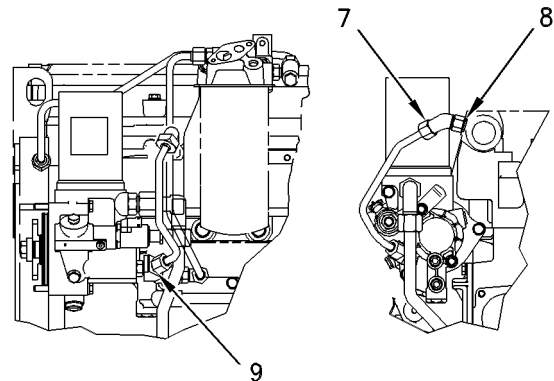

Illustration 3 g00617095

- (7) Tighten the nut on the tube assembly to the following torque. 37 ± 4 N·m (27 ± 3 lb ft)

(8) Tighten the locknut at the cylinder head to the following torque. 48 ± 5 N·m (35 ± 7 lb ft)

(9) Connection of tube assembly to pump outlet

Tighten the nut on the tube assembly to the following torque. 37 ± 4 N·m (27 ± 3 lb ft)

Tighten the locknut at the pump outlet to the following torque. 23 ± 2 N·m (17 ± 1.5 lb ft)

i00867319

Fuel Filter Base

SMCS Code: 1261; 1262

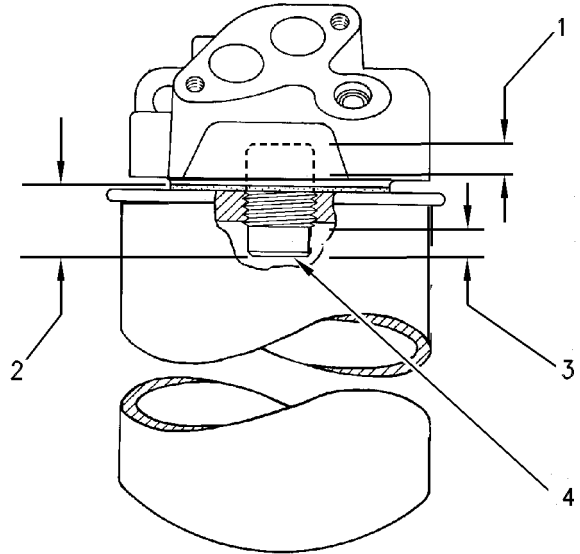

Illustration 5

g00322250

Typical example

(1) Put **4C-9507** Retaining Compound on the tapered end of the stud to the following distance. 7.6 ± 1.5 mm ($.30 \pm .06$ inch)

(2) Distance from the sealing surface of the filter base to the end of the stud 24.6 ± 1.3 mm ($.97 \pm .05$ inch)

(3) Sealing surface of the stud

Note: Do not damage this surface.

(4) Torque for stud .. 68 ± 7 N·m (50.15 ± 5.16 lb ft)

Fuel Filter Lines

SMCS Code: 1274

i00665415

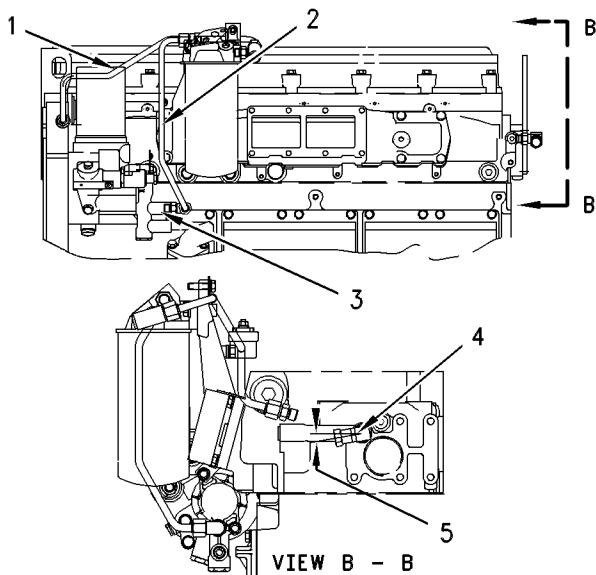

Illustration 4

g00291745

Typical example

Left side of engine

Note: Refer to the System Operation, Testing and Adjusting, "Fuel Pressure" for the correct method of inspecting fuel pressure.

(1) Tube assembly (fuel filter to fuel gallery)

(2) Tube assembly (fuel transfer pump to fuel filter)

(3) Fuel outlet port

(4) The fuel pressure regulator valve maintains minimum fuel system pressure.

Minimum pressure at low idle .. 400 kPa (58 psi)

(5) The position for the fuel pressure regulator valve is 10 Degrees from horizontal.

i01146244

i01510477

Unit Injector

SMCS Code: 1290

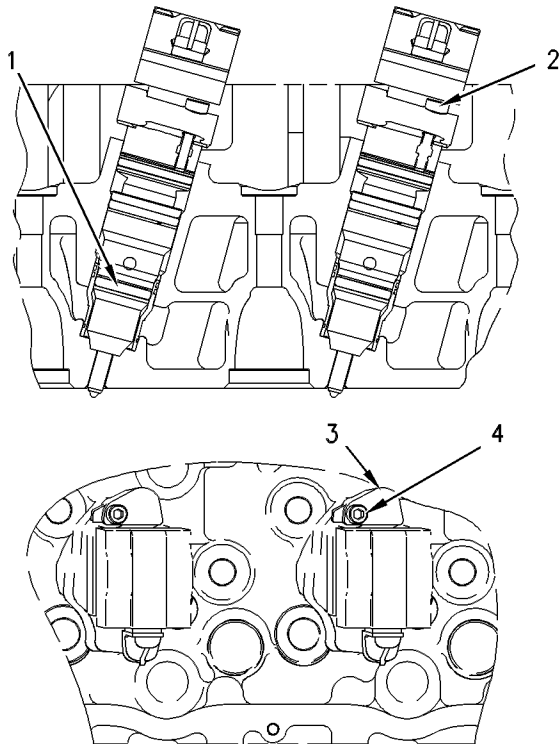

Illustration 6

g00616863

- (1) Lubricate the bore slightly. Use the lubricant that is being sealed.
- (2) Tighten bolt (2) to the following torque. 6 ± 1 N·m (53 ± 9 lb in)
- (3) Position oil deflector (3).
- (4) Tighten bolt (4) to the following torque. 12 ± 3 N·m (106 ± 26 lb in)

Valve Rocker Arms, Lifters, and Bridges

SMCS Code: 1102; 1121; 1209

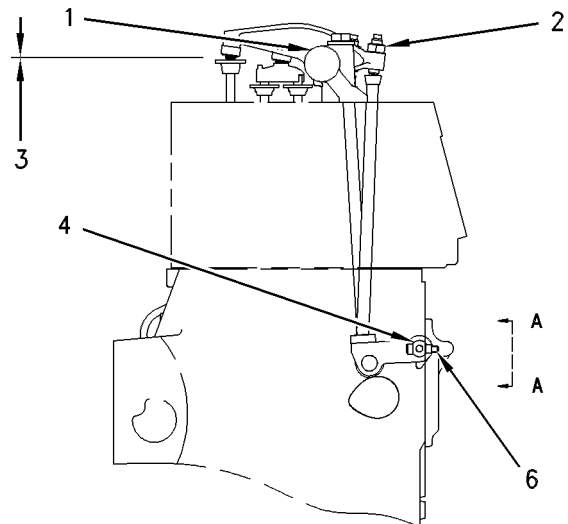

Illustration 7

g00291845

- (1) Valve rocker arm assembly
 - Bore in the rocker arm for the shaft (new) 21.548 ± 0.013 mm (0.8483 ± 0.0005 inch)
 - Diameter of the rocker arm shaft (new) 21.500 ± 0.013 mm (0.8465 ± 0.0005 inch)
- (2) Tighten the locknut to the following torque. 30 ± 7 N·m (22 ± 5 lb ft)
- (3) Valve lash
 - Inlet valves 0.38 mm (0.015 inch)
 - Exhaust valves 0.64 mm (0.025 inch)
- (4) Lifter assembly
 - Bore in the lifter arm for the shaft (new) 15.670 ± 0.013 mm (0.6169 ± 0.0005 inch)
 - Diameter of shaft (new) 15.620 ± 0.018 mm (0.6150 ± 0.0007 inch)

i01146333

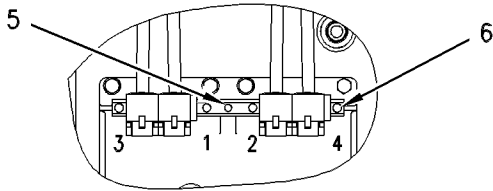

Illustration 8 g00291847
View A-A

- (5) The lifter group must be installed with the oil holes in the shaft, as shown.
- (6) Apply 9S-3263 Thread Lock Compound. Tighten the bolts that are shown above in a numerical sequence to the following torque. 13 ± 3 N·m (10 ± 2 lb ft)

i00666014

Valve Mechanism Cover

SMCS Code: 1107

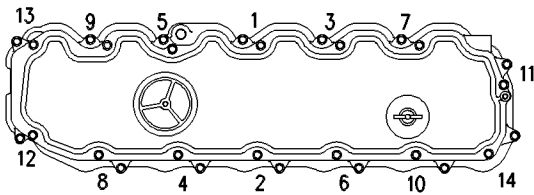

Illustration 9 g00291835
Typical example

Tighten the bolts in a numerical sequence to the following torque. 12 ± 3 N·m (9 ± 2 lb ft)

Cylinder Head Valves

SMCS Code: 1105

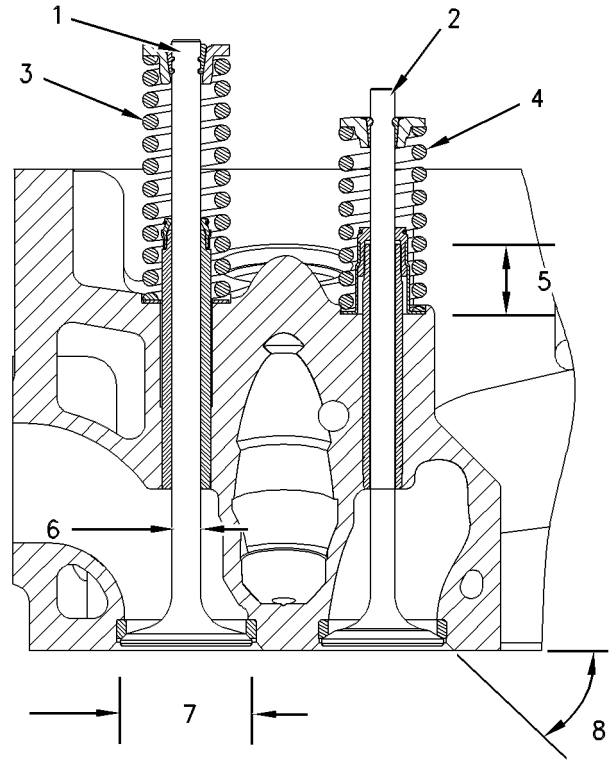

Illustration 10 g00291915

Note: The inlet and exhaust valve stems must be coated with engine oil prior to installation in the cylinder head.

Note: The tips of the inlet and exhaust valves must be coated with 8T-2998 Lubricant. The lubricant must be applied after assembly of the retainer.

- (1) Exhaust valve
- (2) Inlet valve
- (3) 137-6718 Spring for exhaust valve
 - Free length 92.08 mm (3.625 inch)
 - Assembled length 80.27 mm (3.160 inch)
 - Load at assembled length 662 ± 33 N (148 ± 7 lb)
 - Minimum operating length 66.27 mm (2.609 inch)
 - Load at minimum operating length .. 1445 ± 58 N (325 ± 13 lb)
- (4) 140-6188 Spring for inlet valve
 - Free length 67.5 mm (2.66 inch)
 - Assembled length 60.4 mm (2.38 inch)
 - Load at assembled length 303 ± 18 N (68 ± 4 lb)

Minimum operating length 46.4 mm
(1.83 inch)
Load at minimum operating length .. 899 ± 36 N
(202 ± 8 lb)

(5) Height to the top of the valve guides

Inlet valves 23.00 ± 0.50 mm
(0.906 ± 0.020 inch)
Exhaust valves 17.80 ± 0.50 mm
(0.701 ± 0.020 inch)
Diameter of valve guide 12.065 mm
(0.4750 inch)

Note: Install the valve guide from the spring side of the cylinder head.

Note: Assemble the valve guide. Seat the seal against the top of the valve guide.

(6) Valve stem diameter (new)

Inlet valves 8.000 ± 0.008 mm
(0.3150 ± 0.0003 inch)
Exhaust valve 9.441 ± 0.010 mm
(0.3717 ± 0.0004 inch)

The cylinder head valves can be reused if the minimum dimensions for the valve stems are met.

Minimum diameter of a valve stem (worn)

Inlet valve 7.965 mm (0.3136 inch)
Exhaust valve 9.408 mm (0.3704 inch)

After installation into the cylinder head, the valve guide bore is the following value.

Diameter of the valve guide bore (new)

Inlet valve 8.072 ± 0.013 mm
(0.3178 ± 0.0005 inch)
Exhaust valve 9.515 ± 0.013 mm
(0.3746 ± 0.0005 inch)

The valve guide can be reused. The valve guide bore must not be larger than the following value.

Maximum diameter of a valve guide bore (worn)

Inlet valve 8.080 mm (0.3181 inch)
Exhaust valve 9.538 mm (0.3755 inch)

(7) Diameter of the valve head

Inlet valve 40.00 ± 0.13 mm
(1.575 ± 0.005 inch)
Exhaust valve 43.00 ± 0.13 mm
(1.693 ± 0.005 inch)

(8) Angle of the valve faces

Inlet valve 29.75 ± 0.25 degrees

Exhaust valve 45 ± 0.25 degrees

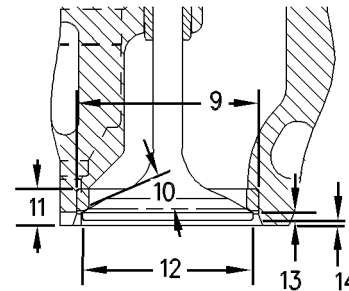

Illustration 11

g00291916

(9) Diameter of the valve seat inserts

Inlet valve 42.000 ± 0.013 mm
(1.6535 ± 0.0005 inch)
Exhaust valve 46.000 ± 0.013 mm
(1.8110 ± 0.0005 inch)

Diameter of the bore in cylinder head for the valve seat insert

Bore diameter

Inlet valve 41.931 ± 0.013 mm
(1.6508 ± 0.0005 inch)
Exhaust valve 45.931 ± 0.013 mm
(1.8083 ± 0.0005 inch)

Note: The valve seat insert must be shrunk by reduced temperature before the valve seat insert is installed in the head.

(10) Angle of the valve seat inserts

Inlet valve 30.25 ± 0.25 degrees
Exhaust valve 44.5 ± 0.25 degrees

(11) Depth of the bore in the head for the valve seat insert 10.00 ± 0.05 mm (0.394 ± 0.002 inch)

(12) Outside diameter of the seating face of the valve seat insert

Inlet valve 37.351 mm (1.4705 inch)
Exhaust valve 40.800 mm (1.6063 inch)

Note: Do not reuse the valve seat inserts if the outside diameter of the valve seat insert is larger than the specified value.

(13) The valve lips can be reused if the minimum dimensions for the valve lips are met.

Inlet valve 2.04 mm (0.080 inch)
Exhaust valve 1.63 mm (0.064 inch)

(14) Distance from the head of the valve to the cylinder head face. The valve must be closed.

Inlet valve

Maximum permissible distance 1.71 mm
(0.067 inch)
Minimum permissible distance 1.09 mm
(0.043 inch)

Exhaust valve

Maximum permissible distance 1.71 mm
(0.067 inch)
Minimum permissible distance 1.09 mm
(0.043 inch)

4. Again tighten bolt (1) through bolt (14) in a numerical sequence to a torque of 130 ± 15 N·m (95 ± 11 lb ft).

5. Turn bolt (1) through bolt (14) in a numerical sequence for an additional 90° (1/4 turn).

6. Tighten bolt (15) through bolt (20) in a numerical sequence to a torque of 55 ± 7 N·m (41 ± 5 lb ft).

(3) The installation depth of the cup plug is measured from the face of the cylinder head to the top edge of the plug. Depth of installation 1.25 ± 0.25 mm
($0.049 \pm .0010$ inch)

i01643428

Cylinder Head

SMCS Code: 1100

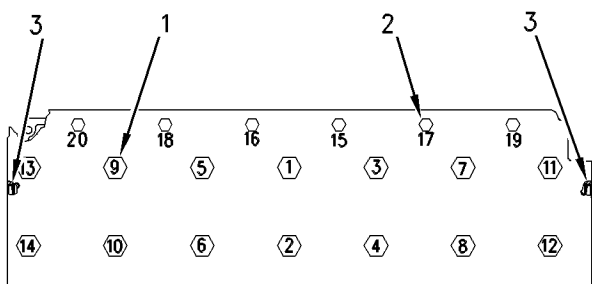

Illustration 12

g00440623

(1) Large bolts

(2) Small bolts

Note: Lubricate the following components with **6V-4876** Lubricant: the bolt threads, the underside of the bolt heads, and the washers.

Tighten the cylinder head bolts according to the following procedure:

1. Tighten bolt (1) through bolt (14) in a numerical sequence to a torque of 300 ± 15 N·m (221 ± 11 lb ft).
2. Loosen bolt (1) through bolt (14) until the washers are loose under the bolt heads.
3. Tighten bolt (1) through bolt (14) in a numerical sequence to a torque of 130 ± 15 N·m (95 ± 11 lb ft).

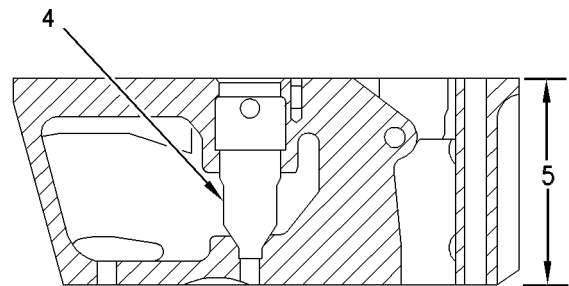

Illustration 13

g00440643

(4) Unit injector sleeve

Refer to Special Instruction, SEHS9120 for information on replacing unit injector sleeves.

(5) Height of new cylinder head .. 103.00 ± 0.20 mm
(4.055 ± 0.008 inch)

i01498172

Turbocharger

SMCS Code: 1052

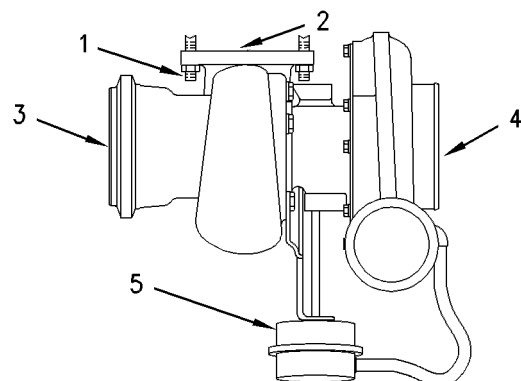

Illustration 14

g00777391

Typical example of turbocharger with a wastegate

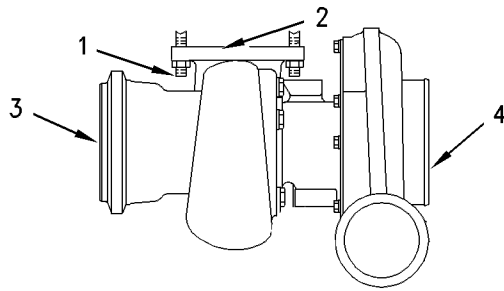

Illustration 15
Typical example of turbocharger without a wastegate

g00777400

i01498928

(1) Stud

Apply **5P-3931** Anti-Seize Compound to the studs.

The **136-0610** Turbocharger and the **136-0611** Turbocharger are secured to the exhaust manifold with the **3E-8017** Locknut. Tighten the **3E-8017** Locknut to the following torque. 54 ± 5 N·m (40 ± 4 lb ft)

Note: The **3E-8017** Locknut has a special thread form that is identifiable from a standard thread. This thread form is called a Spirallock thread.

The **136-0612** Turbocharger and **136-0613** Turbocharger is secured to the exhaust manifold with the **9X-6620** Locknut. Tighten the **9X-6620** Locknut to the following torque. 70 ± 5 N·m (50 ± 4 lb ft)

Note: The **9X-6620** Locknut is a locknut with a standard thread form.

(2) Exhaust inlet

(3) Exhaust outlet

(4) Air inlet

(5) Waste gate

Opening pressure of the wastegate 148 ± 3 kPa (21.5 ± 0.5 psi)

End play for a new shaft $.102 \pm 0.025$ mm ($.0040 \pm .0010$ inch)

Maximum permissible end play for a worn shaft 0.20 mm ($.008$ inch)

Use the following procedure to install the band clamps to hold the cartridge to the compressor housing:

1. Tighten the clamps to a torque of 14 ± 1.1 N·m (125 ± 10 lb in).

2. Tap lightly around the circumference of the clamp.

3. Tighten the clamps again. Tighten the clamps to a torque of 14 ± 1.1 N·m (125 ± 10 lb in).

Note: Put clean engine oil in the oil inlet of the turbocharger after assembly or before installation. This will provide lubrication during start-up and during storage.

Air Inlet Elbow

SMCS Code: 1071

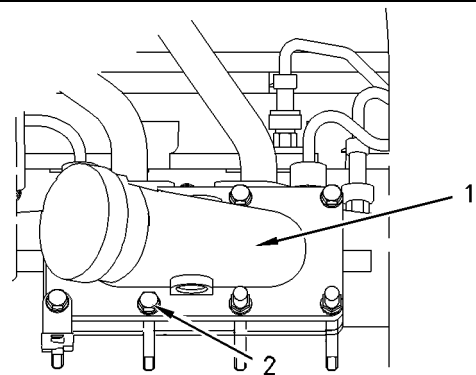

Illustration 16

g00777818

(1) Air Inlet Elbow

Apply **1U-8846** Liquid Gasket to the face of the elbow and spread the sealant uniformly. The elbow must be assembled and the elbow must be tightened within ten minutes.

(2) Tighten the bolts to the following torque. 28 ± 7 N·m (21 ± 5 lb ft)

i01675931

Exhaust Manifold

SMCS Code: 1059

NOTICE

Excessive use of sealant can cause damage to components.

To avoid component damage use only the amount of sealant necessary for the application.

Use the following procedure during assembly of the three-piece exhaust manifold to the cylinder block.

i00873446

1. Mounting surfaces should be clean, and dry. In addition, mounting surfaces should be free of any other foreign matter.
2. Apply 2P-2333 High Temperature Sealer to the outside diameter of the male ends of the exhaust manifold. Do not apply the sealer at the tip of the male ends. Remove any excess sealer from the assembled joint.

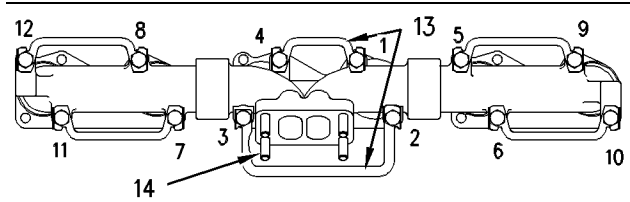

Illustration 17 g00291084

Three-piece exhaust manifold
Typical example

3. Apply 5P-3931 Anti-Seize Compound to the threads of bolt (1) through bolt (12).
4. Tighten bolt (1) through bolt (12) in a numerical sequence.

Tighten the bolts to the following torque. $4 \pm 1 \text{ N}\cdot\text{m}$ ($35 \pm 9 \text{ lb in}$)

5. Tighten bolt (1) through bolt (12) in a numerical sequence.

Tighten the bolts to the following torque. $45 \pm 5 \text{ N}\cdot\text{m}$ ($33 \pm 4 \text{ lb ft}$)

6. Lock the tabs and bend the tabs (13) over the flat of the bolt heads.
7. Tighten the studs (14) to a torque of $35 \pm 5 \text{ N}\cdot\text{m}$ ($26 \pm 4 \text{ lb ft}$).

Note: Prior to starting or running the engine, allow the sealant in the exhaust manifold joints to air dry for 24 hours.

Exhaust Elbow

SMCS Code: 1061

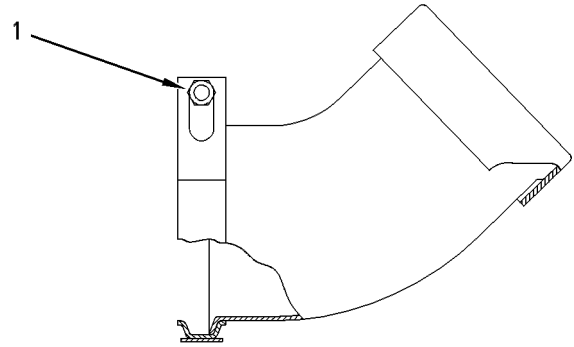

Illustration 18 g00443065

- (1) Tighten the nut for the clamp to the following torque. $12 \pm 4 \text{ N}\cdot\text{m}$ ($9 \pm 3 \text{ lb ft}$)

i01842851

Camshaft

SMCS Code: 1210

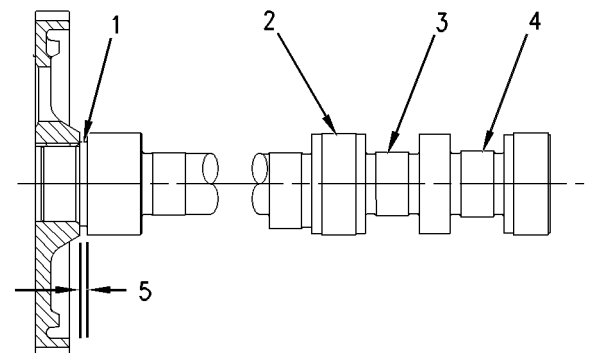

Illustration 19 g00939446

- (1) New thrust washer thickness ... $4.70 \pm 0.03 \text{ mm}$ ($0.185 \pm 0.0012 \text{ inch}$)

End play of a new camshaft $0.13 \pm 0.08 \text{ mm}$ ($0.005 \pm 0.0031 \text{ inch}$)

Maximum permissible end play of a worn camshaft 0.46 mm (0.018 inch)

- (2) Diameter of the camshaft journals $65.126 \pm 0.013 \text{ mm}$ ($2.5640 \pm 0.0005 \text{ inch}$)

(3) Inlet lobe

(4) Exhaust lobe

(5) Distance between the shoulder of the camshaft and the shoulder of the gear

Total distance 4.83 ± 0.05 mm
(0.190 ± 0.002 inch)

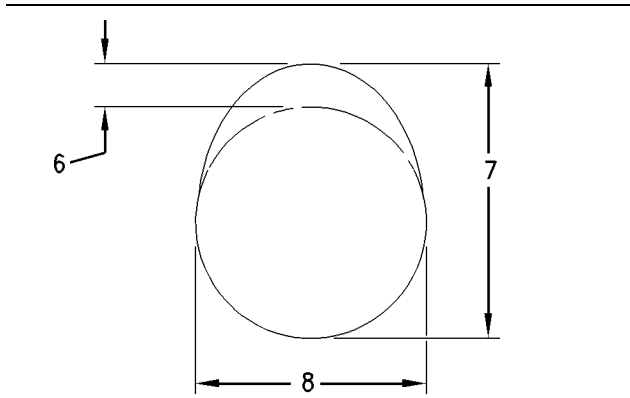

Illustration 20 g00939444

(6) Camshaft lobe lift

Specified camshaft lobe lift (6)

Exhaust lobe 7.707 mm (0.3034 inch)
Inlet lobe 7.970 mm (0.3138 inch)

To find the lobe lift, use the procedure that follows:

1. Measure the camshaft lobe height (7).
2. Measure the base circle (8).
3. Subtract the base circle that is found in Step 2 from the lobe height that is found in Step 1. The difference is the actual camshaft lobe lift (6).

Maximum permissible difference between actual lobe lift and the specified lobe lift of a new camshaft ± 0.10 mm (0.004 inch)

i00664110

Engine Oil Filter Base

SMCS Code: 1306

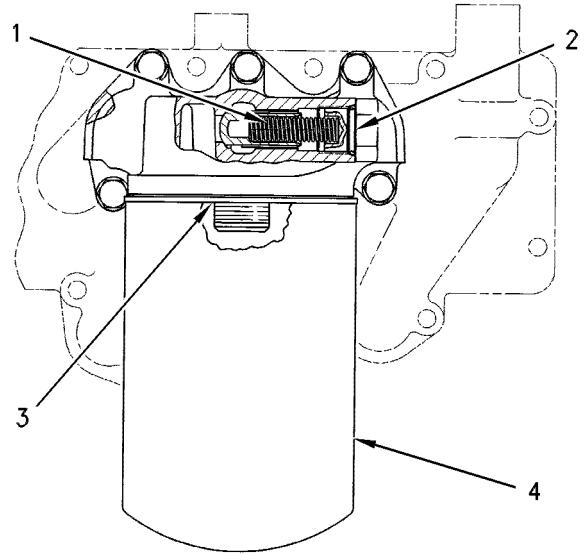

Illustration 21 g00291396

(1) The **9L-9188** Spring is located in the filter bypass valve:

Outside diameter 11.2 mm (0.44 inch)
Free length 57.9 mm (2.28 inch)
Assembled length 43.2 mm (1.70 inch)
Load at assembled length 15.6 ± 1.3 N
(3.50 ± 0.30 lb)

(2) The oil filter bypass valve must open at the following pressure. 125 ± 30 kPa
(18 ± 4.5 psi)

(3) Put **9S-3263** Thread Lock Compound on the last 7.5 ± 1.5 mm (0.30 ± 0.06 inch) of the threads at the base end of the stud.

Tighten the stud to the following torque. .. 68 ± 7 N·m
(50 ± 5 lb ft)

(4) Put clean engine oil on the filter seal. Tighten the filter until the seal contacts the base. After the seal contacts the base, rotate the filter by 270 degrees.

i00667186

i01582205

Engine Oil Cooler Bypass Valve

SMCS Code: 1314

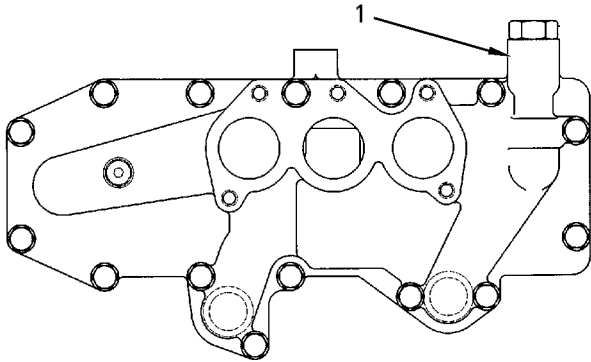

Illustration 22

g00292073

Typical example

(1) The oil cooler bypass valve will open at the following pressure. 125 ± 30 kPa
(18 ± 4.5 psi)

9L-9188 Spring specifications for the oil cooler bypass valve

Outside diameter 11.2 mm (.44 inch)
Free length 57.9 mm (2.28 inch)
Assembled length 43.2 mm (1.70 inch)
Load at assembled length 15.6 ± 1.3 N
(3.50 ± 0.30 lb)

Engine Oil Pump

SMCS Code: 1304

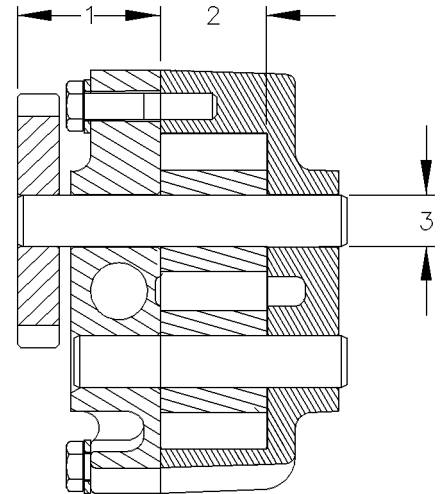

Illustration 23

g00292581

Section view through pump gears

Typical example

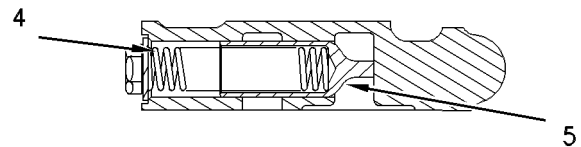

Illustration 24

g00292582

The section view is of the bypass valve that is located in the pump assembly.

(1) Distance between the front face of the gear and the housing 43.00 ± 0.25 mm
(1.693 ± 0.010 inch)

(2) Length of the gears 33.00 ± 0.03 mm
(1.299 ± 0.001 inch)

Depth of the bores for the gears .. 33.13 ± 0.02 mm
(1.304 ± 0.001 inch)

(3) Diameter of the gear shafts .. 15.600 ± 0.005 mm
(0.6142 ± 0.0002 inch)

Bores in the pump bodies for the gear shafts .. 15.641 ± 0.008 mm (0.6158 ± 0.0003 inch)

(4) **105-1805** Spring for relief valve

Outside diameter 13.0 mm (0.51 inch)
Free length 64.98 mm (2.558 inch)
Assembled length 54.5 mm (2.15 inch)

Load at assembled length 51.99 ± 1.9 N
(12 ± 0.4 lb)

(5) Relief valve plunger

Diameter of the plunger 17.000 ± 0.013 mm
(0.6693 ± 0.0005 inch)

Bore in the pump body for the
plunger 17.100 ± 0.025 mm
(0.6732 ± 0.0010 inch)

i00880101

Engine Oil Pan

SMCS Code: 1302

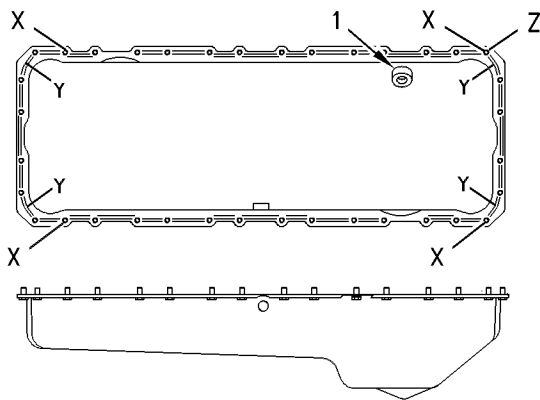

Illustration 25

g00448568

(1) Tighten the drain plug to the following torque. 50 ± 5 N·m (37 ± 4 lb ft)

Apply **1U-8846** Liquid Gasket to four areas on the sealing surface of the oil pan. The areas are marked location (Y). The areas are at the corners of the oil pan in the following locations:

- connecting joint of the front housing and the front of the cylinder block
- connecting joint of the flywheel housing and the rear of the cylinder block

Use the following procedure to tighten the bolts for the oil pan.

Tighten four bolts (X).

Start with bolt (Z) and tighten all remaining bolts in a counterclockwise sequence.

Tighten the bolts to the following torque. 31 ± 3 N·m (23 ± 2 lb ft)

Start again with bolt (Z) and tighten all remaining bolts in a counterclockwise sequence.

Tighten the bolts to the following torque. 31 ± 3 N·m (23 ± 2 lb ft)

i00873547

Crankcase Breather

SMCS Code: 1317

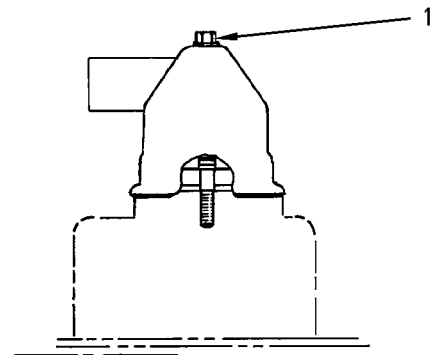

Illustration 26

g00330803

Typical example

(1) Tighten the bolt that holds the breather cap to the following torque. .. 7 ± 2 N·m (62 ± 18 lb in)

i01574749

Water Temperature Regulator

SMCS Code: 1355

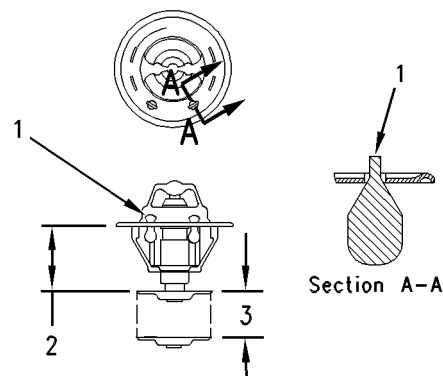

Illustration 27

g00291249

Fully open temperature of the water temperature regulator 97°C (206°F)

- (1) Air vent valve
- (2) Closed dimension of the water temperature regulator 29.5 ± .5 mm (1.16 ± 0.02 inch)
- (3) Minimum stroke of the water temperature regulator at fully open temperature 8.00 mm (.315 inch)

i01847619

Cylinder Block Cover Group

SMCS Code: 1201

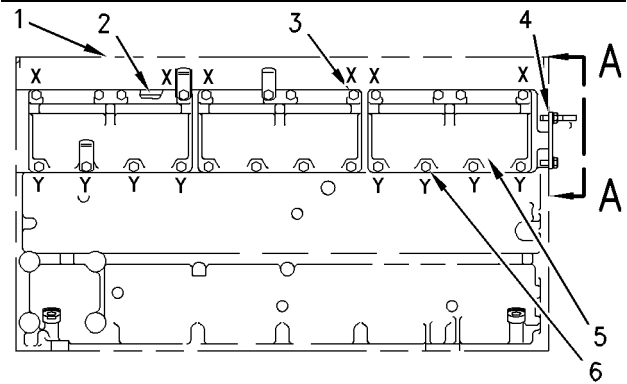

Illustration 29

g00941125

Left side view of engine (typical example)

Water Pump

SMCS Code: 1361

i00669873

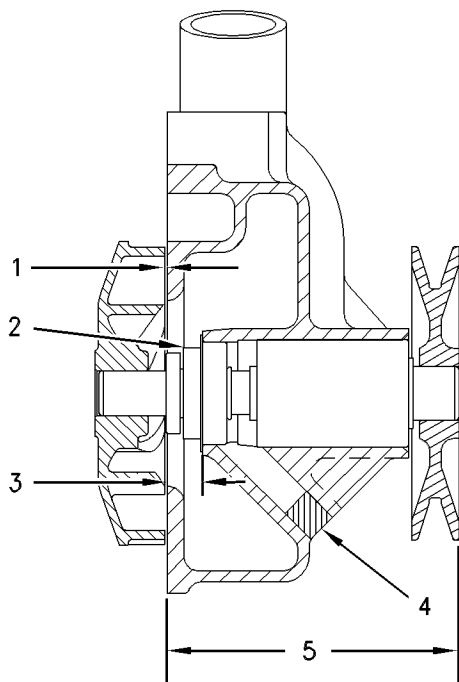

Illustration 28

g00292733

The impeller cover is not shown.

- (1) Clearance between the impeller and the housing 0.75 ± 0.25 mm (.030 ± .010 inch)
- (2) Seal
- (3) Height of seal 12.83 ± 0.13 mm (.505 ± .005 inch)
- (4) The filter should not extend beyond the surface of the housing.
- (5) Dimension from the front face of the pulley to the face of the housing 103.8 ± 0.3 mm (4.09 ± .01 inch)

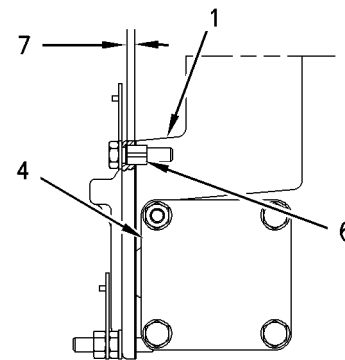

Illustration 30

g00945478

View A-A

- (1) Cylinder block

- (2) Gasket

Gasket (2) has a bead on one surface. Install the gasket so that the bead is facing side cover (5).

- (3) Six sleeves marked location (X).

- (4) Cover

Clean the face of the cover with solvent. Apply **1U-8846** Liquid Gasket to the cover. Spread uniformly on the face of the cover and around the bolt holes. The cover must be installed and tightened within ten minutes.

- (5) Side cover

- (6) Eight spacers marked location (Y).

- (7) Sleeve (3) extends from the face of cylinder block (1). Distance 5.0 ± 0.5 mm (0.20 ± 0.02 inch)

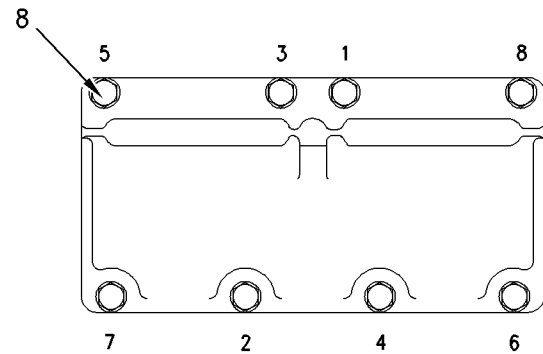

Illustration 31 g00945479
Bolt tightening sequence for side cover (typical example)

- (8) Tighten bolts (1 through 8) in a numerical sequence.

Tighten the bolts to the following torque. 28 ± 7 N·m (21 ± 5 lb ft)

i01574825

Cylinder Block

SMCS Code: 1201

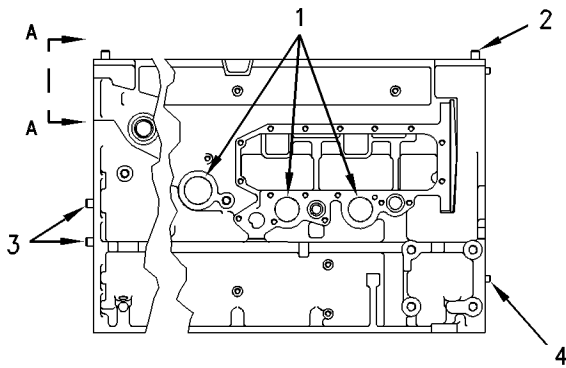

Illustration 32 g00292819

- (1) The installation depth of the cup plug is measured from the block face to the top edge of the plug. Distance 1.25 ± 0.25 mm (.049 ± .010 inch)
- (2) The dowels extend past the top face of the cylinder block. Distance 14 ± 2 mm (.55 ± .080 inch)
- (3) The two large dowels extend past the rear face of the cylinder block. Distance .. 12.0 ± 0.5 mm (.47 ± .02 inch)

- (4) The dowels extend past the front face of the cylinder block. Distance 8.0 ± 0.5 mm (.31 ± .02 inch)

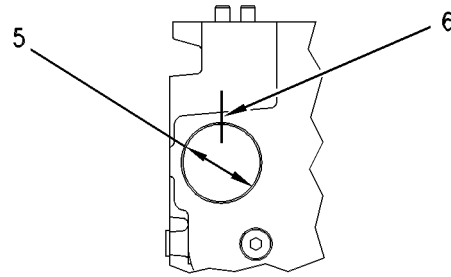

Illustration 33 g00292820
View A-A

- (5) Bore diameters in the cylinder block for all camshaft bearings except the front bearing 69.000 ± 0.038 mm (2.7165 ± .0015 inch)
- (6) Locate the bearing oil hole for all camshaft bearings at the top of the bore. The front camshaft bearing is not located at the top of the bore.

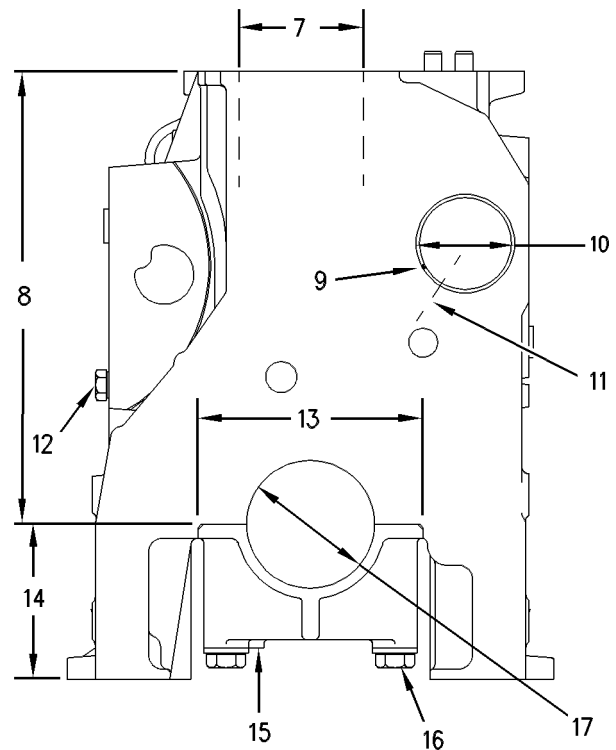

Illustration 34 g00292821

- (7) Diameter of cylinder bore .. 110.025 ± 0.025 mm
(4.3317 ± 0.0010 inch)
- (8) Distance from the centerline of the crankshaft bore to the top surface of the cylinder block .. 322.00 ± 0.17 mm (12.677 ± 0.007 inch)
- (9) Front camshaft bearing joint location
- (10) Bore diameter in the cylinder block for the front camshaft bearing 70.000 ± 0.025 mm
(2.7559 ± .0010 inch)
- (11) Front camshaft bearing oil hole

Note: The front camshaft bearing is installed with the bearing oil hole (11) in alignment with the oil hole in the cylinder block and the bearing joint (9) in the position that is shown.

- (12) Tighten the bolt to the following torque. 70 ± 10 N·m (50 ± 7 lb ft)
- (13) Bearing cap
 - Width of the main bearing cap 159.995 ± 0.020 mm
(6.2990 ± .0008 inch)
 - Width of the cylinder block for the main bearing 160.000 ± 0.018 mm
(6.2992 ± .0007 inch)

- (14) Distance from the centerline of the crankshaft bore to the pan rail 110.00 mm (4.331 inch)
- (15) Location of the sequence number for the bearing cap
- (16) Main bearing cap bolts

Install the bearing caps with the sequence number to the right. The order is 1 through 7 (front to rear).

1. Apply **4C-5593** Anti-Seize Compound to the bolt threads (16) and face of the washers.
2. Tighten bolts (16) on each bearing cap.
 - Tighten to the following torque. 54 ± 7 N·m
(40 ± 5 lb ft)
3. Tighten bolts (16) on each bearing cap again.
 - Tighten the bolts by another one quarter of a turn. 90 ± 5 degrees

- (17) Bore in the cylinder block for the seven main bearings 95.000 ± 0.013 mm
(3.7402 ± 0.0005 inch)

Note: Additional information on reconditioning procedures can be ordered. Refer to the following documents:

Guideline For Reusable Parts And Salvage Operations, SEBF8192, "Specifications and Salvage for Cylinder Blocks on 3114, 3116, 3126 and 3126B Engines"

Guideline For Reusable Parts And Salvage Operations, SEBF8261, "Installing a **7C-6208** Cylinder Sleeve in 3114 and 3116 Engines and a **107-7604** Cylinder Sleeve in 3126 Engines"

i01839706

Crankshaft

SMCS Code: 1202

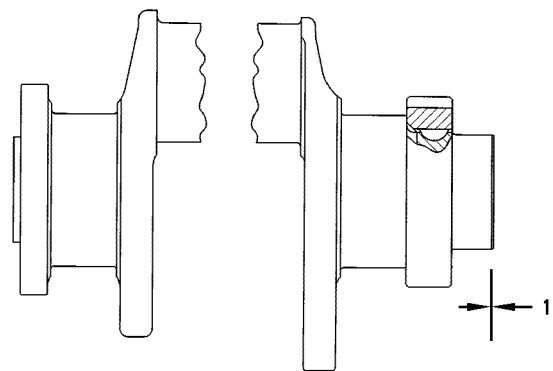

Illustration 35

g00939552

- (1) Crankshaft end play 0.07 to 0.32 mm
(0.003 to 0.013 inch)

i01733982

Crankshaft Seals

SMCS Code: 1160; 1161

Note: For the complete procedure on removing and installing the crankshaft seals, refer to Disassembly and Assembly.

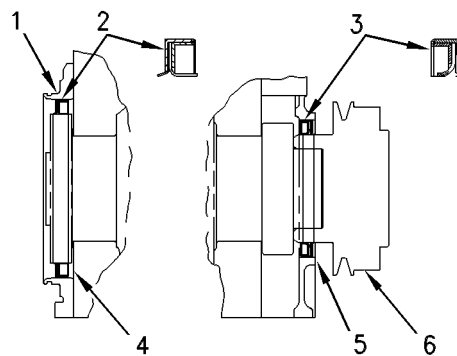

Illustration 36

g00291469

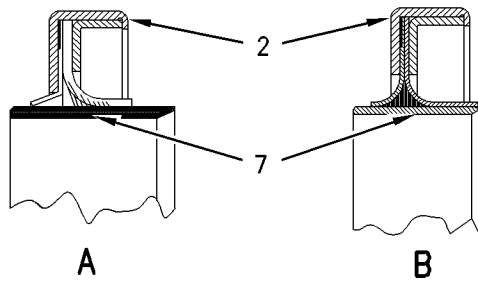

Illustration 37 g00291470

The single lip seal is used for dry applications (A).
The double lip seal is used for wet applications (B).

- (1) Carrier housing and flywheel housing
- (2) Rear seal

Install the rear seal. Make sure that the rear face of the seal (2) is 15.4 ± 0.5 mm (0.61 ± 0.02 inch) from the block's rear face (4).

Note: The original rear seal runs directly on the crankshaft flange. The original seal assembly does not contain a wear sleeve. The Service Rear seal group contains a wear sleeve (7).

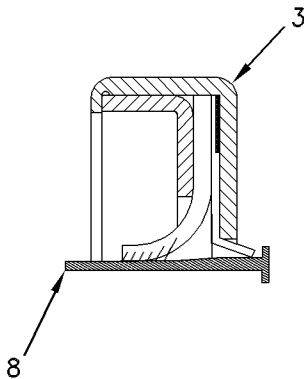

Illustration 38 g00291471

Front crankshaft seal

- (3) Front seal

Install the front seal. Make sure that the front face of the seal (3) is 2.5 ± 0.5 mm (0.10 ± 0.02 inch) from the front housing (5).

- (4) Rear face of block
- (5) Front housing
- (6) Pulley

- (7) Wear sleeves

Do not remove the wear sleeves from the seal group.

- (8) Shipping sleeve for the front seal

Install the front seal (3) in the housing. Remove the shipping sleeve (8). Install the pulley (6).

i00873707

Rear Seal Carrier (If Equipped)

SMCS Code: 1161

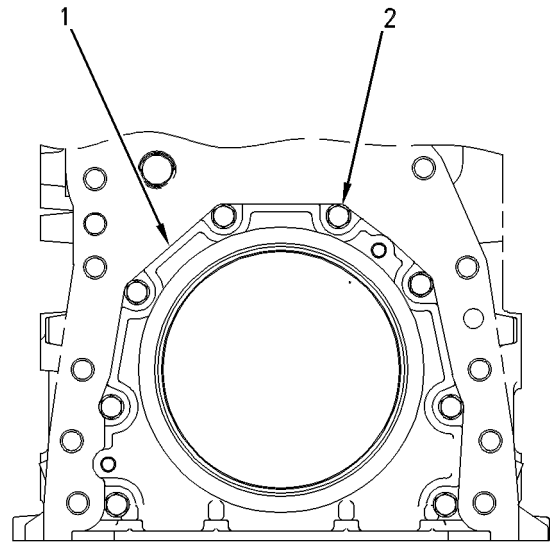

Illustration 39 g00443494

- (1) Apply **1U-8846** Liquid Gasket to the joint face of the seal carrier. Spread the liquid gasket uniformly on the joint face. The seal carrier must be assembled and tightened to the cylinder block within ten minutes.
- (2) Apply **9S-3263** Thread Lock Compound to the threads of the eight bolts.

i01161520

i01135346

Vibration Damper

SMCS Code: 1205

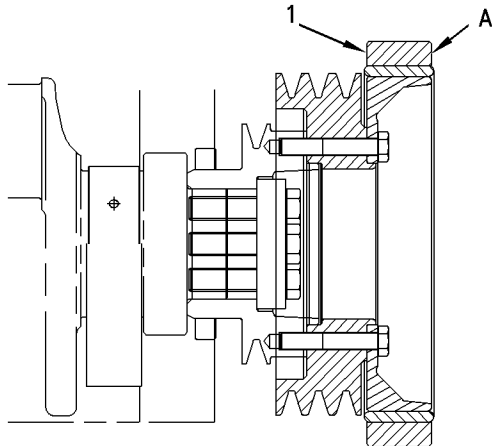

Illustration 40

g00618602

Rubber vibration damper

(1) Damper assembly

Note: The dash marks on the front of the damper assembly must be in alignment with each other. A new damper assembly will be needed if the dash marks are not in alignment.

Maximum permissible face runout of the damper assembly at location (A) 0.00 to 2.03 mm (0.000 to 0.080 inch)

i01135341

Connecting Rod Bearing Journal

SMCS Code: 1202; 1219; 1225

Table 1

Diameter Of Crankshaft Journal (Bearing Surface) For Connecting Rod Bearings	
Original Size Journal	70.000 ± 0.020 mm (2.7559 ± 0.0008 inch)
Undersize Journal 0.25 mm (0.010 inch)	69.750 ± 0.020 mm (2.7461 ± 0.0008 inch)
Undersize Journal 0.50 mm (0.020 inch)	69.500 ± 0.020 mm (2.7362 ± 0.0008 inch)

Clearance between bearing and new journal .. 0.053 to 0.155 mm (0.0021 to 0.0061 inch)

Main Bearing Journal

SMCS Code: 1202; 1203

Table 2

Diameter Of Crankshaft Journal (Bearing Surface) For Main Bearings	
Original Size Journal	90.000 ± 0.020 mm (3.5433 ± 0.0008 inch)
Undersize Journal 0.25 mm (0.010 inch)	89.750 ± 0.020 mm (3.5335 ± 0.0008 inch)
Undersize Journal 0.50 mm (0.020 inch)	89.500 ± 0.020 mm (3.5236 ± 0.0008 inch)

Clearance between bearing and new journal .. 0.071 to 0.173 mm (0.0028 to 0.0068 inch)

i01721187

Connecting Rod

SMCS Code: 1218

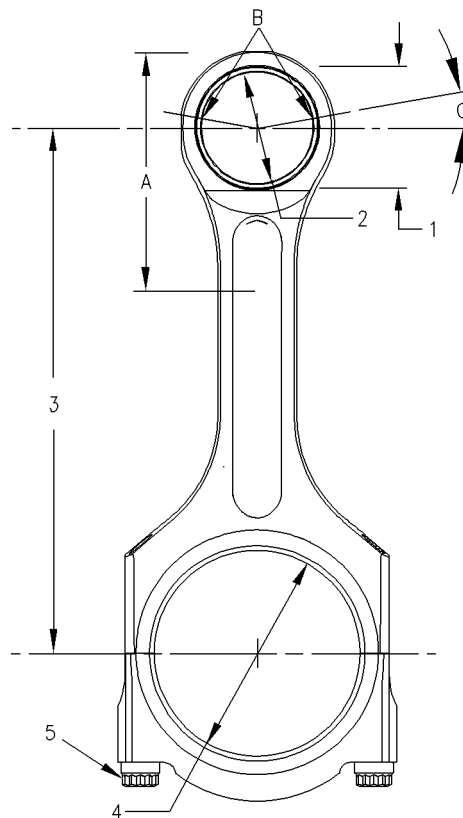

Illustration 41

g00888747

Note: Handle the fractured connecting rod with care. Use a soft jawed vise in order to hold the connecting rod while loosening the connecting rod cap bolts. Use a soft faced hammer in order to tap the connecting rod cap, if necessary.

The connecting rod small end must be heated from 175 to 260°C (347 to 500°F) before the installation of the piston pin bearing.

Apply heat only within length (A) of the connecting rod. 75 ± 5 mm (3.0 ± .2 inch)

The bearing joint for the piston pin bearing (B) must be positioned at 12 ± 5 degrees (C) above the centerline on either side.

(1) Bore size for the piston pin bearing

Bore in the connecting rod for the piston pin bearing 43.191 ± 0.013 mm
(1.7004 ± 0.0005 inch)

(2) Bore size for the piston pin after the installation of the bearing

Bore in the piston pin bearing 40.028 ± 0.008 mm
(1.5759 ± 0.0003 inch)

(3) Distance between the center of the connecting rod bores 200 mm (7.9 inch)

(4) Crankshaft bore in the connecting rod for connecting rod journal 75.000 ± 0.013 mm
(2.9527 ± 0.0005 inch)

Note: Use the following procedure to tighten the connecting rod bolts before measuring the crankshaft bore. Check the dimensions of the crankshaft bore only after the tightening procedure has been followed.

(5) Connecting rod bolts

Use the instructions that follow in order to tighten the connecting rod cap bolts:

1. Before installing the rod cap, clean the mating surfaces of the connecting rod with compressed air or a steel brush. Ensure that there are no loose particles that remain from the process that is used to fracture the rod.

Note: Lubricate the seating faces of the rod cap bolts with 5P-3931 Anti-Seize Compound or engine oil before installing the bolts.

2. Install new connecting rod cap bolts (5).

Tighten each of the cap bolts to the following torque. 54 ± 5 N·m (40 ± 4 lb ft)

3. Place an index mark on each connecting rod cap bolt and tighten each of the cap bolts for an additional 60 ± 5 degrees (1/6 of a turn).

i01569859

Piston and Rings

SMCS Code: 1214; 1215

Two-Piece Articulated Piston

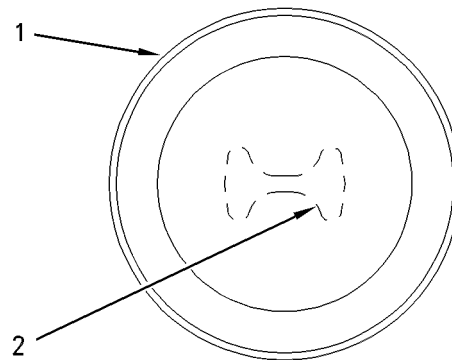

Illustration 42

g00293184

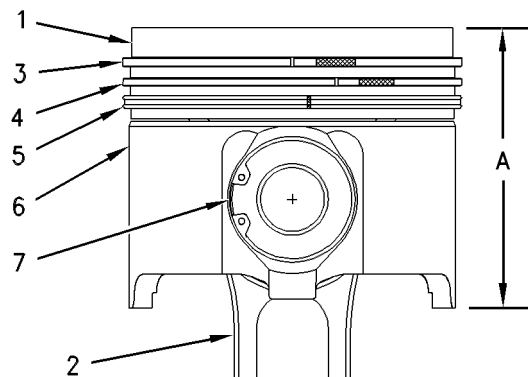

Illustration 43

g00293185

(1) Crown assembly

(2) Connecting rod

Note: Install the rod and piston group in the engine with the part number to the rear of the engine. The rear of the engine is the flywheel end of the engine. Lubricate the rod and piston group with clean engine oil before you insert the rod and piston group into the block.

Top Ring and Intermediate Ring

(3) The top ring has the mark "UP-1".

Install the piston ring with the side marked "UP-1" toward the top of the piston. The colored stripe faces to the right of the ring end gap.

The ends of the piston ring have a clearance when the piston ring is installed in a cylinder with a specific bore size.

Cylinder bore size 110.03 mm (4.332 inch)

Clearance 0.4 ± 0.1 mm (0.016 ± 0.004 inch)

The piston ring has an increase in clearance for each 0.03 mm (0.001 inch) increase in the cylinder liner bore.

Increase 0.09 mm (0.004 inch)

(4) The intermediate ring has the mark "UP-2".

Install the piston ring with the side marked "UP-2" toward the top of the piston. The colored stripe faces to the right of the piston ring end gap.

Thickness of the new piston ring ... 2.98 ± 0.01 mm
(0.1173 ± 0.0004 inch)

The ends of the piston ring have a clearance when the piston ring is installed in a cylinder with a specific bore size.

Cylinder bore size 110.03 mm (4.332 inch)

Clearance 0.825 ± 0.125 mm
(0.0325 ± 0.0049 inch)

The intermediate piston ring has an increase in clearance for each 0.03 mm (.001 inch) increase in the cylinder liner bore.

Increase 0.09 mm (0.004 inch)

Oil Control Ring

(5) The oil control piston ring has a spring that is installed with the ring. The gap in the spring should be a distance of 180 degrees from the ring end gap when the oil control piston ring is assembled. The light green colored portion of the spring must be visible at the ring end gap.

Width of the groove in a new piston for the oil control piston ring 4.041 ± 0.013 mm
(0.1591 ± 0.0005 inch)

Thickness of the new piston ring .. 3.985 ± 0.010 mm
(0.1569 ± 0.0004 inch)

Clearance between the oil groove and the oil control piston ring 0.033 ± 0.079 mm
(0.0013 ± 0.0031 inch)

The ends of the oil control piston ring have a clearance when the ring is installed in a cylinder with a specific bore size.

Cylinder bore size 110.03 mm (4.332 inch)

Clearance 0.45 ± 0.15 mm (0.018 ± 0.006 inch)

The oil control piston ring has an increase in clearance for each 0.03 mm (0.001 inch) increase in the cylinder liner bore.

Increase 0.09 mm (0.004 inch)

After the piston rings have been installed, rotate the piston rings so that the end gaps are 120 degrees from each other.

(6) Piston skirt

Lubricate the entire piston in zone (A) prior to assembly into the cylinder block. Use clean engine oil.

Piston Pin Bore

(7) Piston pin

Piston pin bore diameter that is in the crown assembly 40.031 ± 0.007 mm
(1.5760 ± 0.0003 inch)

Piston pin bore diameter that is in the piston skirt 40.020 ± 0.005 mm
(1.5756 ± 0.0002 inch)

Piston pin diameter 40.000 ± 0.005 mm
(1.5748 ± 0.0002 inch)

Length of piston pin 89.95 ± 0.15 mm
(3.541 ± 0.006 inch)

Thoroughly lubricate the piston pin with clean engine oil prior to assembly.

i01234648

i01358291

Piston Cooling Jet

SMCS Code: 1331

Two-Piece Articulated Piston

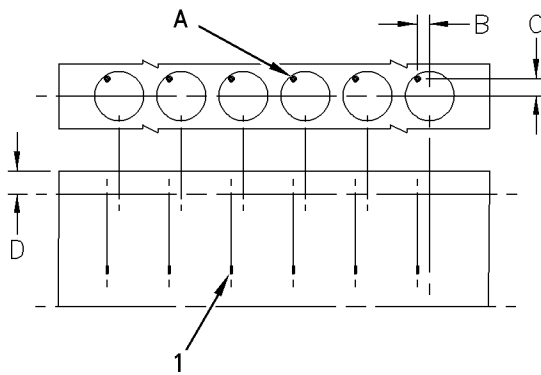

Illustration 44

g00657849

(1) Piston cooling jet

The piston cooling jets must be checked for the location of the stream of oil. Insert a drill rod with a diameter of 1.90 mm (0.075 inch) into the orifice. This drill rod simulates the stream of oil under normal operating pressure. The drill rod must pass through a circle with a diameter of 5.0 mm (0.20 inch) at point (A).

Use the following dimensions in order to locate point (A).

- Dimension (B) 26.5 mm (1.04 inch)
- Dimension (C) 34.0 mm (1.34 inch)
- Dimension (D) 50.0 mm (1.97 inch)

Front Housing and Covers

SMCS Code: 1162; 1166

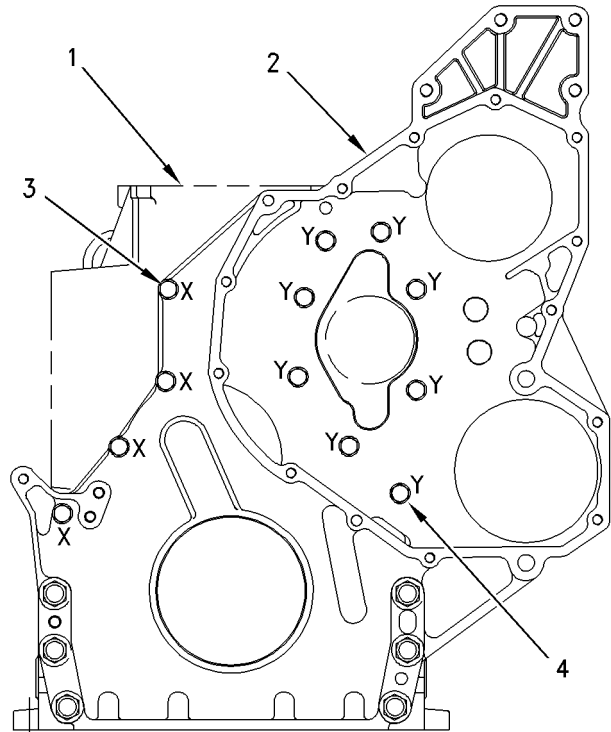

Illustration 45

g00716820

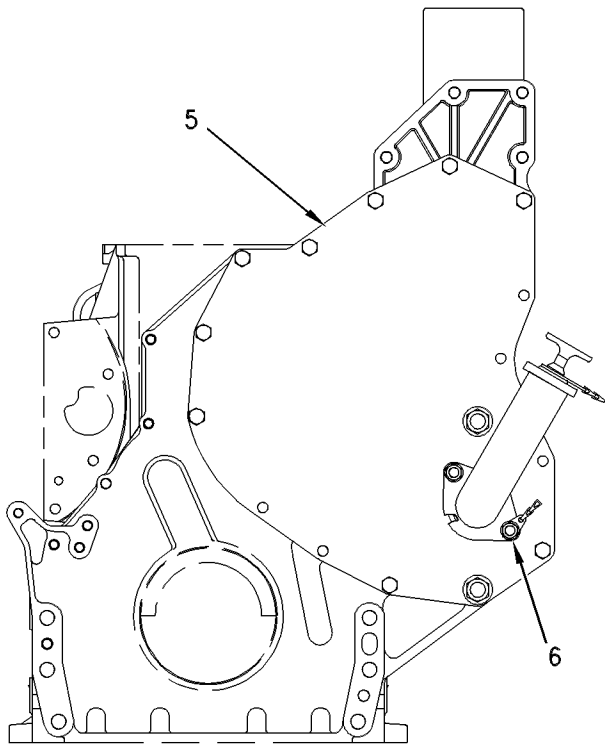

Illustration 46

g00293311

Apply **1U-8846** Liquid Gasket to the front housing sealing surfaces before assembling the front housing to the cylinder block. The front housing must be assembled and tightened to the cylinder block within ten minutes.

- (1) Cylinder Block
- (2) Front housing
- (3) Bolts (X) 50.0 mm (1.97 inch)
- (4) Bolts (Y) 20.0 mm (.79 inch)
- (5) Front housing cover
- (6) Apply **9S-3263** Thread Lock Compound to the serrations of the studs before installation.

i01574837

Gear Group (Front)

SMCS Code: 1206

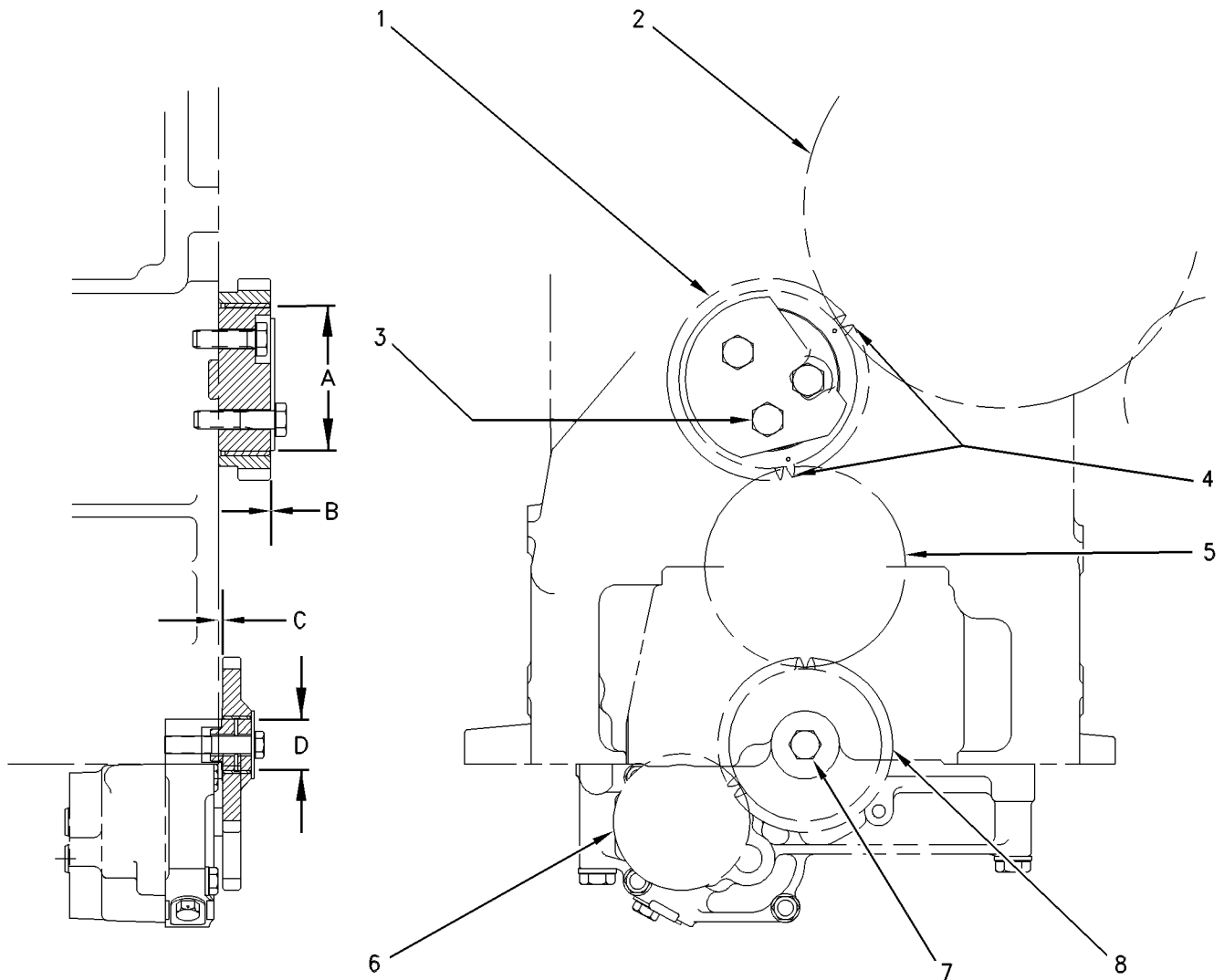

Illustration 47

g00293531

(1) Camshaft idler gear

Distance between the front of the bearing face and the front of the gear face (B) 0.40 ± 0.25 mm
(0.016 ± 0.010 inch)

Diameter of new shaft (A) 80.00 ± 0.013 mm
(3.1496 ± 0.0005 inch)

(2) Camshaft gear

(3) Tighten the bolts of the camshaft idler gear to the following torque. 70 ± 15 N·m
(50 ± 11 lb ft)

(4) Align the timing marks on the camshaft idler gear (1) with the holes on the camshaft (2) and the crankshaft gear (5).

(5) Crankshaft gear

(6) Oil pump drive gear

(7) Apply **9S-3263** Thread Lock Compound to the threads of the oil pump idler gear bolt. Tighten the bolt to the following torque. 70 ± 15 N·m
(50 ± 11 lb ft)

(8) Oil pump idler gear

Distance between the rear of the bearing face and the rear of the gear face (C) 0.75 ± 0.25 mm
(0.030 ± 0.010 inch)

Diameter of new shaft (D) 28.644 ± 0.013 mm
(1.1277 ± 0.0005 inch)

i00672569

Flywheel

SMCS Code: 1156

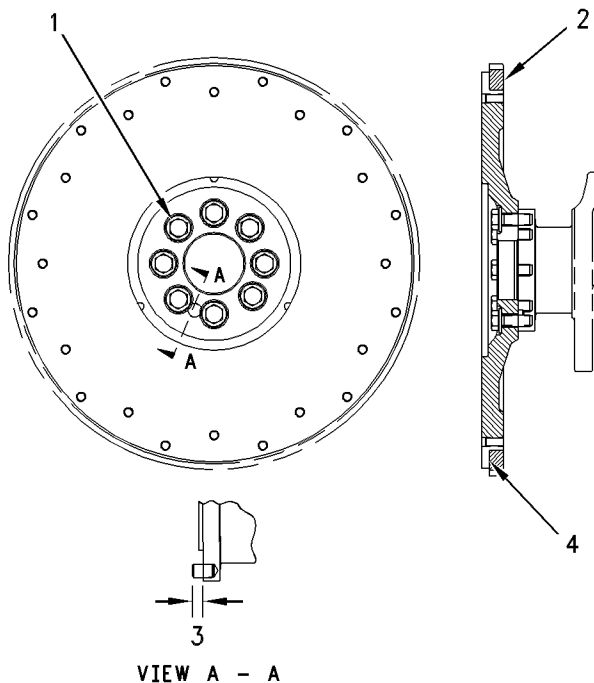

Illustration 48

g00293319

Note: Refer to System Operation, Testing and Adjusting for the correct method of inspecting the flywheel.

- (1) Bolt
- (2) Ring gear
- (3) Spring pin
- (4) Shoulder

The following instructions should be used during installation of the ring gear:

1. Install the flywheel ring gear. Face the “part number” on the ring gear (2) toward the engine block. The flywheel ring gear must be installed against the shoulder (4). The flywheel ring gear can be heated for installation. Do not use a torch.

Maximum temperature 204°C (400°F)

2. Press the spring pin (3) into the crankshaft before assembling the flywheel to the crankshaft. Check the distance from the face of the crankshaft to the end of the pin (3).

Distance 11.0 ± 1.0 mm ($.43 \pm .04$ inch)

3. Tighten the bolts (1) that hold the flywheel to the crankshaft.

Tighten to the following torque. 120 ± 20 N·m
(90 ± 15 lb ft)

i00672686

Flywheel Housing

SMCS Code: 1157

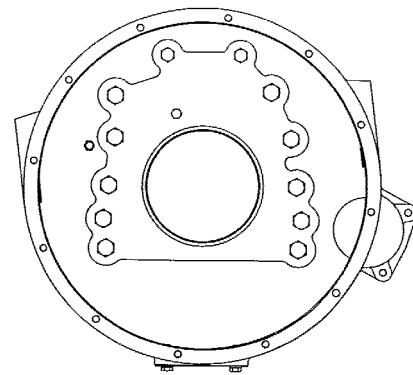

Illustration 49

g00293373

Mounting face for the block

Note: Refer to Systems Operation, Testing and Adjusting for the correct method of inspecting the flywheel housing.

Note: Apply **1U-8846** Liquid Gasket to all of the sealing surfaces of the flywheel housing . The flywheel housing must be assembled and tightened to the block within ten minutes.

i00670847

Crankshaft Pulley

SMCS Code: 1205

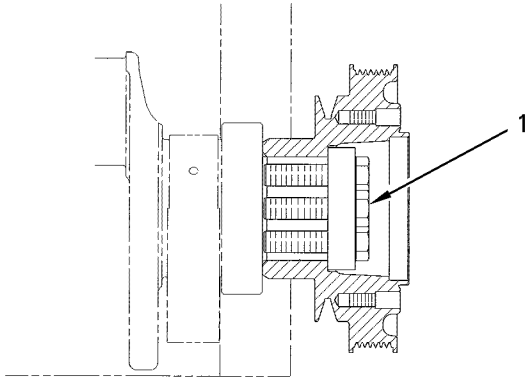

Illustration 50

g00293042

- (1) Tighten the bolts to the following torque. $200 \pm 25 \text{ N}\cdot\text{m}$ ($150 \pm 18 \text{ lb ft}$)

i01617888

Belt Tension Chart

SMCS Code: 1357

Note: Do not use the belt tension charts for belts with tensioners that are spring loaded.

Table 3

Belt Tension Chart					
Size of Belt	Width of Belt	Gauge Reading		Kent-Moore Gauge Numbers	
		Belt Tension "Initial" ⁽¹⁾	Belt Tension "Used" ⁽²⁾⁽³⁾	Number of the Old Gauge	Number of the New Gauge
3/8	10.72 mm (0.422 inch)	534 ± 111 N (120 ± 25 lb)	400 ± 22 N (90 ± 5 lb)	BT-33-97	BT 3397
1/2	13.89 mm (0.547 Inch)	578 ± 111 N (130 ± 25 lb)	445 ± 44 N (100 ± 10 lb)	BT-33-97	BT 3397
5V	15.88 mm (0.626 Inch)	712 ± 111 N (160 ± 25 lb)	445 ± 44 N (100 ± 10 lb)	BT-33-72C	BT 3372C
11/16	17.48 mm (0.688 Inch)	712 ± 111 N (160 ± 25 lb)	445 ± 44 N (100 ± 10 lb)	BT-33-72C	BT 3372C
3/4	19.05 mm (0.750 Inch)	712 ± 111 N (160 ± 25 lb)	445 ± 44 N (100 ± 10 lb)	BT-33-72C	BT 3372C
15/16	23.83 mm (0.938 Inch)	712 ± 111 N (160 ± 25 lb)	445 ± 44 N (100 ± 10 lb)	BT-33-77	BT 3372C
8PK	27.82 mm (1.095 inch)	1068 ± 111 N (240 ± 25 lb)	890 ± 44 N (200 ± 10 lb)	BT-33-109	BT 33109
6PK	20.94 mm (0.824 Inch)	801 ± 111 N (180 ± 25 lb)	667 ± 44 N (150 ± 10 lb)	BT-33-109	BT 33109
Measure the tension of the belt that is farthest from the engine.					

(1) Belt tension "Initial" is for a new belt.

(2) Belt tension "Used" is for a belt that has operated for 30 minutes or more of operation at the rated speed.

(3) If a belt falls below the "Used" belt tension, the belt should be tightened again to the high side of the "Used" belt tension.

Table 4

For DAYCO Supplied Belts Only		
Size of Belt	Belt Tension "Initial" ⁽¹⁾	Belt Tension "Used" ⁽²⁾⁽⁴⁾
.380 (V-Belt)	623 ± 22 N (140 ± 5 lb)	245 - 534 N (100 ± 5 lb)
.440 (V-Belt)	667 ± 22 N (150 ± 5 lb)	245 - 534 N (100 ± 5 lb)
.500 (V-Belt)	712 ± 22 N (160 ± 5 lb)	245 - 534 N (100 ± 5 lb)
.600 (V-Belt)	779 ± 22 N (175 ± 5 lb)	245 - 534 N (100 ± 5 lb)
.660 (V-Belt)	890 ± 22 N (200 ± 5 lb)	245 - 534 N (100 ± 5 lb)
.790 (V-Belt)	890 ± 22 N (200 ± 5 lb)	245 - 534 N (100 ± 5 lb)
4 - RIB PVK	623 ± 22 N (140 ± 5 lb)	267 - 445 N (90 ± 5 lb)
5 - RIB PVK	779 ± 22 N (175 ± 5 lb)	334 - 556 N (100 ± 5 lb)
6 - RIB PVK	934 ± 22 N (210 ± 5 lb)	400 - 667 N (130 ± 5 lb)
8 - RIB PVK	1157 ± 22 N (260 ± 5 lb)	534 - 890 N (180 ± 5 lb)
10 - RIB PVK	1557 ± 22 N (350 ± 5 lb)	667 - 1112 N (230 ± 5 lb)
12 - RIB PVK	1869 ± 22 N (420 ± 5 lb)	800 - 1335 N (270 ± 5 lb)
15 - RIB PVK	2336 ± 22 N (525 ± 5 lb)	1000 - 1669 N (350 ± 5 lb)

(1) Belt tension "Initial" is for a new belt.

(2) Belt tension "Used" is for a belt that has operated for 30 minutes or more of operation at the rated speed.

(4) If a belt falls below the "Used" belt tension, the belt should be tightened again to the "Initial" belt tension.

i00675918

Belt Tensioner (If Equipped)

SMCS Code: 1358

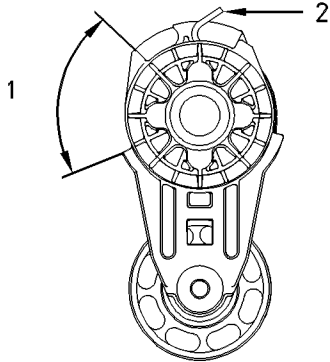

Illustration 51

g00294094

- (1) Minimum travel 71 degrees
- (2) The torque for the spring is 14.1 ± 1.7 N·m (10 ± 1 lb ft) at 25 degrees from the released position.

i00670033

Belt Tightener

SMCS Code: 1358

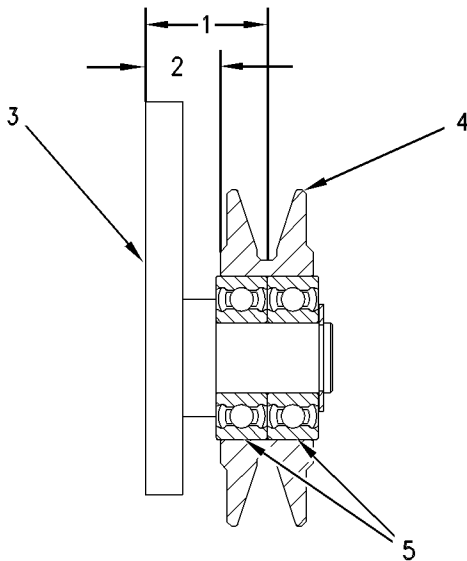

Illustration 52

g00292814

- (1) Distance from the back of the plate assembly to the middle of the pulley 26.0 ± 0.3 mm ($1.02 \pm .012$ inch)

- (2) Distance from the back of the plate assembly to the back of the pulley 16.0 ± 0.3 mm ($.63 \pm .01$ inch)

(3) Plate assembly

(4) Pulley

(5) Apply 9S-3263 Thread Lock Compound to the pulley bore before assembly.

i00670126

Fan Drive

SMCS Code: 1359

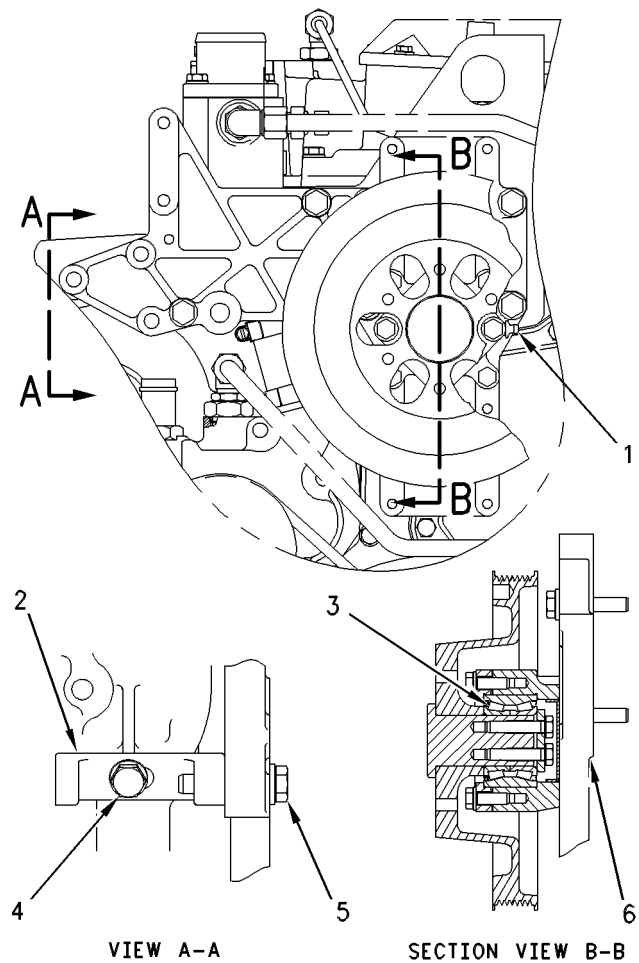

Illustration 53

g00292816

- (1) Use the grease fitting to fill the bearing cavity with 30 grams (1.05 ounces) of 2S-3230 Grease Cartridge lubricant. Apply the grease to the bearing cavity after installing fan drive bearings.

(2) Bracket

- (3) Bearing assembly
- (4) Bolt
- (5) Bolt
- (6) Support

i00675120

Engine Oil Pressure Sensor (If Equipped)

SMCS Code: 1924

Assembly procedure for the bracket

1. Tighten bolt (4) by hand into the housing.
2. Tighten bolt (5) by hand into the bracket (2).
3. Tighten bolts (4) and (5).

Tighten the bolts to the following torque. 55 ± 10 N·m (40 ± 7 lb ft)

i01649768

Coolant Temperature Sensor

SMCS Code: 1906

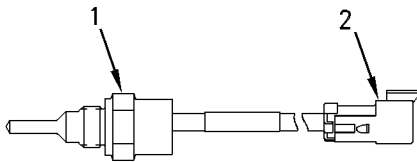

Illustration 54

g00293958

Typical example

- (1) Sensor assembly
- (2) Plug

Tighten the sensor assembly to the following torque. 20 ± 3 N·m (15 ± 3 lb ft)

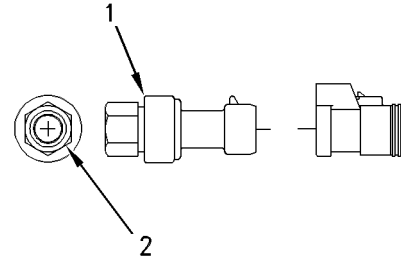

Illustration 55

g00293960

Typical example

- (1) Sensor assembly

Tighten the sensor assembly to the following torque. 10 ± 2 N·m (90 ± 18 lb in)

- (2) Port fitting

i00676593

Engine Oil Temperature Sensor (If Equipped)

SMCS Code: 1929

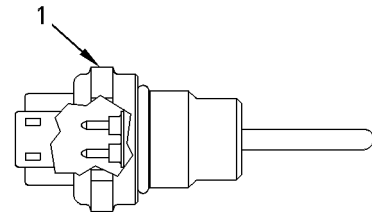

Illustration 56

g00294228

- (1) Sensor assembly

Tighten the sensor assembly to the following torque. 10 ± 2 N·m (90 ± 18 lb in)

i00675169

Boost Pressure Sensor

SMCS Code: 1917

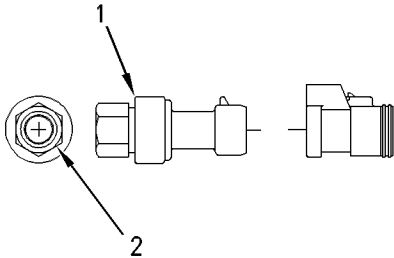

Illustration 57

g00293962

Typical example

(1) Sensor assembly

Tighten the sensor assembly to the following torque: 10 ± 2 N·m (90 ± 18 lb in)

(2) Port fitting

Atmospheric Pressure Sensor (If Equipped)

SMCS Code: 1923

i01161328

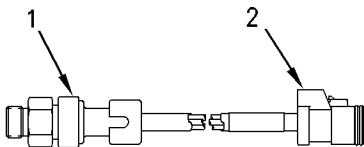

Illustration 58

g00293963

Typical example

(1) Sensor assembly

Tighten the sensor assembly to the following torque: 10 ± 2 N·m (90 ± 18 lb in)

(2) Plug

i01331712

Inlet Air Temperature Sensor

SMCS Code: 1921

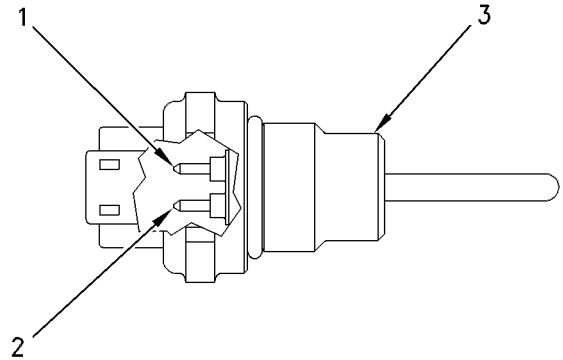

Illustration 59

g00526991

(1) Pin for the signal circuit

(2) Pin for the ground circuit

(3) Tighten the sensor assembly to the following torque: 20 ± 5 N·m (15 ± 4 lb ft)

i00677047

Speed and Timing Sensor

SMCS Code: 1907; 1912

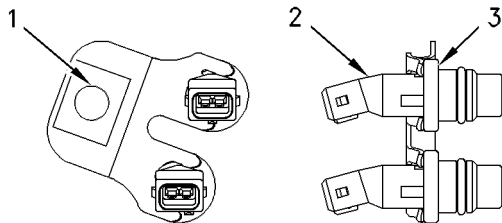

Illustration 60

g00295489

(1) Bracket

(2) Sensor

(3) Flange

Seat both sensors to the sensor's flanges before tightening the bolt to the bracket.

The sensors must be replaced as a pair.

i01147860

Air Inlet Heater

SMCS Code: 1090

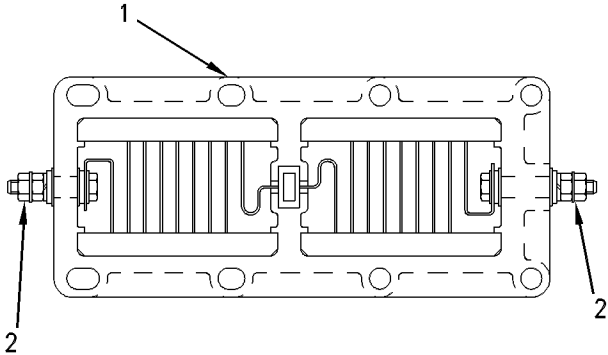

Illustration 61

g00292365

Section view of the air inlet heater

- (1) Air inlet heater
- (2) Tighten the nuts to the following torque. 8 ± 1 N·m (71 ± 9 lb in)

Note: During assembly of the air inlet heater to the inlet manifold and the air inlet elbow, clean the air inlet heater's joint faces with solvent. Apply **4C-9500** Quick Cure Primer to the joint faces. Allow the primer to air dry for a minimum of three to five minutes. Apply **1U-8846** Liquid Gasket to the joint face and spread the gasket maker uniformly. The heater must be assembled and tightened within ten minutes.

Index

A

Air Inlet Elbow.....	10
Air Inlet Heater.....	31
Atmospheric Pressure Sensor (If Equipped)	30

B

Belt Tension Chart.....	26
Belt Tensioner (If Equipped)	28
Belt Tightener.....	28
Boost Pressure Sensor.....	30

C

Camshaft	11
Connecting Rod.....	19
Connecting Rod Bearing Journal	19
Coolant Temperature Sensor.....	29
Crankcase Breather.....	14
Crankshaft	17
Crankshaft Pulley	26
Crankshaft Seals	17
Cylinder Block.....	16
Cylinder Block Cover Group	15
Cylinder Head.....	9
Cylinder Head Valves	7

E

Engine Design	4
Engine Oil Cooler Bypass Valve.....	13
Engine Oil Filter Base.....	12
Engine Oil Pan.....	14
Engine Oil Pressure Sensor (If Equipped).....	29
Engine Oil Pump.....	13
Engine Oil Temperature Sensor (If Equipped).....	29
Exhaust Elbow.....	11
Exhaust Manifold	10

F

Fan Drive	28
Flywheel	25
Flywheel Housing	25
Front Housing and Covers.....	22
Fuel Filter Base	5
Fuel Filter Lines.....	5
Fuel Transfer Pump (Fuel Transfer Pump and High Pressure Oil Pump)	4

G

Gear Group (Front)	24
--------------------------	----

I

Important Safety Information	2
Inlet Air Temperature Sensor.....	30

M

Main Bearing Journal	19
----------------------------	----

P

Piston and Rings	20
Two-Piece Articulated Piston	20
Piston Cooling Jet.....	22
Two-Piece Articulated Piston	22

R

Rear Seal Carrier (If Equipped).....	18
--------------------------------------	----

S

Specifications Section	4
Speed and Timing Sensor	30

T

Table of Contents.....	3
Turbocharger	9

U

Unit Injector	6
---------------------	---

V

Valve Mechanism Cover	7
Valve Rocker Arms, Lifters, and Bridges	6
Vibration Damper.....	19

W

Water Pump.....	15
Water Temperature Regulator	14

Systems Operation Testing and Adjusting

3126E Truck Engine

LEF1-Up (Engine)



Important Safety Information

Most accidents that involve product operation, maintenance and repair are caused by failure to observe basic safety rules or precautions. An accident can often be avoided by recognizing potentially hazardous situations before an accident occurs. A person must be alert to potential hazards. This person should also have the necessary training, skills and tools to perform these functions properly.

Improper operation, lubrication, maintenance or repair of this product can be dangerous and could result in injury or death.

Do not operate or perform any lubrication, maintenance or repair on this product, until you have read and understood the operation, lubrication, maintenance and repair information.

Safety precautions and warnings are provided in this manual and on the product. If these hazard warnings are not heeded, bodily injury or death could occur to you or to other persons.

The hazards are identified by the "Safety Alert Symbol" and followed by a "Signal Word" such as "DANGER", "WARNING" or "CAUTION". The Safety Alert "WARNING" label is shown below.



The meaning of this safety alert symbol is as follows:

Attention! Become Alert! Your Safety is Involved.

The message that appears under the warning explains the hazard and can be either written or pictorially presented.

Operations that may cause product damage are identified by "NOTICE" labels on the product and in this publication.

Caterpillar cannot anticipate every possible circumstance that might involve a potential hazard. The warnings in this publication and on the product are, therefore, not all inclusive. If a tool, procedure, work method or operating technique that is not specifically recommended by Caterpillar is used, you must satisfy yourself that it is safe for you and for others. You should also ensure that the product will not be damaged or be made unsafe by the operation, lubrication, maintenance or repair procedures that you choose.

The information, specifications, and illustrations in this publication are on the basis of information that was available at the time that the publication was written. The specifications, torques, pressures, measurements, adjustments, illustrations, and other items can change at any time. These changes can affect the service that is given to the product. Obtain the complete and most current information before you start any job. Caterpillar dealers have the most current information available.



When replacement parts are required for this product Caterpillar recommends using Caterpillar replacement parts or parts with equivalent specifications including, but not limited to, physical dimensions, type, strength and material.

Failure to heed this warning can lead to premature failures, product damage, personal injury or death.

Table of Contents

Systems Operation Section

Engine Design	4
General Information	5
Glossary of Electronic Control Terms	7
Electronic Control System Components	11
Fuel System	15
Air Inlet and Exhaust System	44
Lubrication System	50
Cooling System	52
Basic Engine	55
Electrical System	57

Testing and Adjusting Section

Fuel System

Fuel System - Inspect	59
Air in Fuel - Test	60
Engine Speed - Check	61
Finding Top Center Position for No. 1 Piston	62
Fuel Quality - Test	63
Fuel System - Prime	63
Fuel System Pressure - Test	64
Gear Group (Front) - Time	66
Unit Injector - Test	66

Air Inlet and Exhaust System

Air Inlet and Exhaust System - Inspect	68
Turbocharger - Inspect	71
Inlet Manifold Pressure - Test	74
Exhaust Temperature - Test	75
Aftercooler - Test	75
Engine Crankcase Pressure (Blowby) - Test	78
Compression - Test	79
Engine Valve Lash - Inspect/Adjust	79

Lubrication System

Engine Oil Pressure - Test	82
Engine Oil Pump - Inspect	85
Excessive Bearing Wear - Inspect	85
Excessive Engine Oil Consumption - Inspect	85
Increased Engine Oil Temperature - Inspect	86

Cooling System

Cooling System - Check (Overheating)	87
Cooling System - Inspect	89
Cooling System - Test	90
Water Temperature Regulator - Test	94
Water Pump - Test	95

Basic Engine

Piston Ring Groove - Inspect	96
Connecting Rod Bearings - Inspect	96
Main Bearings - Inspect	96
Cylinder Block - Inspect	96
Flywheel - Inspect	97
Flywheel Housing - Inspect	98
Vibration Damper - Check	100

Electrical System

Battery - Test	101
Belt Tension Chart	102
Charging System - Test	103
Electric Starting System - Test	104
Engine Oil Pressure Sensor - Test	105

Index Section

Index	106
-------------	-----

Systems Operation Section

i01147099

Engine Design

SMCS Code: 1000

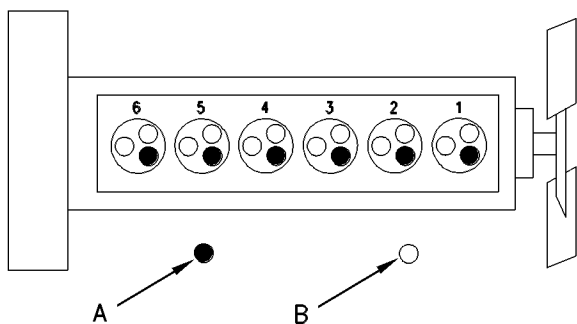

Illustration 1 g00290846

Cylinder And Valve Location

(A) Exhaust valve.

(B) Inlet valve.

Bore 110 mm (4.3 inch)

Stroke 127 mm (5.0 inch)

Displacement 7.25 L (442 in³)

Number of cylinders 6

Cylinder arrangement In-line

Valves per cylinder 3

In order to check the engine valve lash setting, the engine must be cold and the engine must be stopped. Engine valve lash settings

Inlet 0.38 mm (0.015 inch)

Exhaust 0.64 mm (0.025 inch)

Type of combustion Direct Injection

Firing Order 1 - 5 - 3 - 6 - 2 - 4

The crankshaft rotation is viewed from the flywheel end of the engine. Crankshaft rotation counterclockwise

Note: The front end of the engine is opposite the flywheel end of the engine. The left side of the engine and the right side of the engine are viewed from the flywheel end of the engine. The number one cylinder is the front cylinder.

i01748261

General Information

SMCS Code: 1000

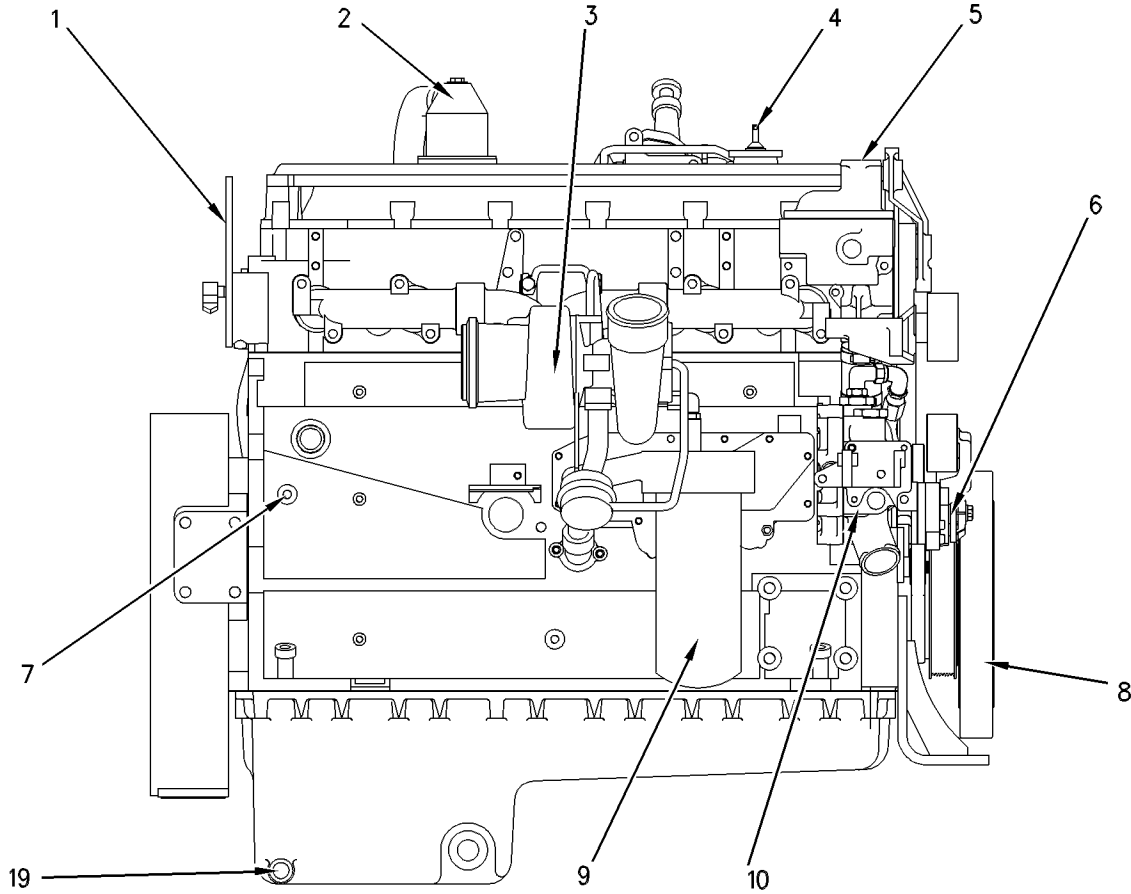

Illustration 2

g00608514

Right side view

- | | |
|---|---------------------------------|
| (1) Lifting eye | (6) Belt tensioner |
| (2) Engine crankcase breather | (7) Water drain plug |
| (3) Turbocharger | (8) Crankshaft vibration damper |
| (4) Oil filler | (9) Oil filter |
| (5) Water temperature regulator housing | (10) Jacket water pump |

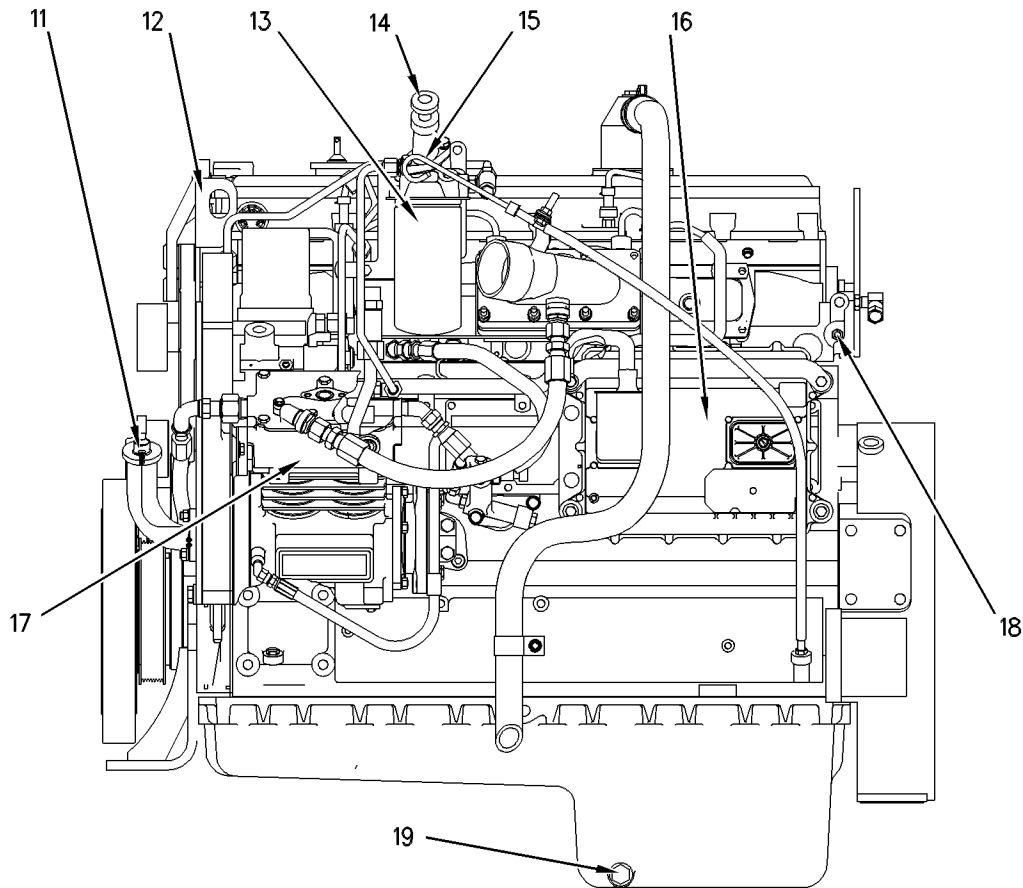

Illustration 3

g00608515

Left side view

- | | | |
|------------------|--|-----------------------------------|
| (11) Oil filler | (14) Fuel priming pump (if equipped) | (17) Air compressor |
| (12) Lifting eye | (15) Oil level gauge (typical example) | (18) Cylinder head grounding stud |
| (13) Fuel filter | (16) Engine Control Module (ECM) | (19) Oil drain plug |

The 3126B and 3126E engines are in-line six cylinder arrangements. The firing order of the engine is 1-5-3-6-2-4. The engine's rotation is counterclockwise when the engine is viewed from the flywheel end of the engine. The engine utilizes a turbocharger and an air-to-air aftercooler. The engines have a bore of 110 mm (4.3 inch) and a stroke of 127 mm (5.0 inch). The displacement is 7.25 L (442 in³).

The hydraulic electronic unit injector system (HEUI) eliminates many of the mechanical components that are used in a pump-and-line system. The HEUI also provides increased control of the timing and increased control of the fuel air mixture. The timing advance is achieved by precise control of the unit injector timing. Engine rpm is controlled by adjusting the injection duration. A special pulse wheel provides information to the Engine Control Module (ECM) for detection of cylinder position and engine rpm.

The engine has built-in diagnostics in order to ensure that all of the components are operating properly. In the event of a system component failure, the operator will be alerted to the condition via the check engine light that is located on the dashboard. An electronic service tool can be used to read the numerical code of the faulty component or condition. Also, the cruise control switches can be used to flash the code on the check engine light. Intermittent faults are logged and stored in memory.

Starting The Engine

The engine's ECM will automatically provide the correct amount of fuel in order to start the engine. Do not hold the throttle down while the engine is cranking. If the engine fails to start in twenty seconds, release the starting switch. Allow the starting motor to cool for two minutes before the starting motor is used again.

NOTICE

Excessive ether (starting fluid) can cause piston and ring damage. Use ether for cold weather starting purposes only.

Cold Mode Operation

Starting the engine and operation in cold weather is dependent on the type of fuel that is used, the oil viscosity, and other optional starting aids. For more information, refer to the Operation and Maintenance Manual, "Cold Weather Operation" topic (Operation Section).

i01564336

Glossary of Electronic Control Terms

SMCS Code: 1900

Accelerator Pedal Position Sensor – The accelerator pedal position sensor is an electronic sensor that is connected to the accelerator pedal. The accelerator pedal position sensor sends a Pulse Width Modulated Signal to the ECM.

After Market Device – An after market device is a device or an accessory that is installed by the customer after the vehicle is delivered.

Air-To-Air Aftercooler – An air-to-air aftercooler is a device that is used on turbocharged engines in order to cool inlet air that has undergone compression. The inlet air is cooled after the inlet air passes through the turbocharger. The inlet air is passed through an aftercooler (heat exchanger) that uses ambient air for cooling. The inlet air that has been cooled advances to the inlet manifold.

American Wire Gauge (AWG) – AWG is a measure of the diameter of electrical wire. AWG is also a measure of the current carrying capacity of electrical wire. When the AWG number is smaller, the diameter of the wire is larger. When the AWG number is larger, the diameter of the wire is smaller.

Atmospheric Pressure Sensor – The atmospheric pressure sensor measures barometric pressure. The sensor sends a signal to the ECM. The signal is used in engine control and in engine operation.

Before Top Center (BTC) – BTC is the 180 degrees of crankshaft rotation before the piston reaches the top center position in the normal direction of rotation.

Boost Pressure Sensor – The boost pressure sensor measures inlet manifold air pressure. The boost pressure sensor sends a signal to the ECM.

Bypass Circuit – A bypass circuit is a circuit that is used as a substitute circuit for an existing circuit. A bypass circuit is typically used as a test circuit.

Calibration – Calibration is an electronic adjustment of a sensor signal.

Coolant Temperature Sensor – The coolant temperature sensor measures the engine coolant temperature. The sensor sends a signal to the ECM. The engine's coolant temperature is used in Cold Mode operation. Coolant temperature is also used in order to optimize engine performance.

Cruise Control Range – The cruise control range establishes the vehicle speed range for the operation of cruise control. The range is usually limited to the speed range that is anticipated on the open road.

Code – See the Diagnostic Code.

Customer Specified Parameters – A customer specified parameter is a parameter that can be changed. A customer specified parameter's value is set by the customer. These parameters are protected by customer passwords.

CAT Data Link – The data link is an electrical connection that is used to communicate with other microprocessor based devices. The microprocessor based devices are compatible with the proposed American Trucking Association and the SAE Standard. These devices include trip recorders, electronic dashboards, and maintenance systems. The data link is also the communication medium that is used for programming with the electronic service tool. The data link is also used for troubleshooting with the electronic service tool.

Desired RPM – The desired rpm is input to the electronic governor within the ECM. The electronic governor uses the signal from the Accelerator Pedal Position Sensor, the Engine Speed Sensor, the Cruise Control, and the Customer Parameters in order to determine desired rpm.

Diagnostic Code – A diagnostic code is sometimes called a fault code. A diagnostic code is an indication of a problem or event in the electrical engine systems.

Diagnostic Lamp – A diagnostic lamp is sometimes called the check engine light. The diagnostic lamp is used to warn the operator of the presence of an active diagnostic code.

Direct Current (DC) – Direct current is the type of current that flows consistently in only one direction.

Duty Cycle – See Pulse Width Modulation.

Engine Control Module (ECM) – The ECM is the engine's control computer. The ECM provides power to the electronics. The ECM monitors data that is input from the engine's sensors. The ECM acts as a governor in order to control engine rpm.

Electronic Engine Control – The electronic engine control is a complete electronic system. The electronic engine control monitors the engine operation under all conditions. The electronic engine control also controls the engine operation under all conditions.

Electronic Technician (ET) – The electronic service tool of choice for Caterpillar engines is ET. ET is used for diagnosing a variety of electronic controls. ET is also used for programming a variety of electronic controls.

Estimated Dynamic Timing – Estimated dynamic timing is the estimate of actual injection timing by the ECM.

Enable Signal for the Exhaust Brake – The enable signal for the exhaust brake interfaces with the ECM to the engine retarder. This prevents the operation of the exhaust brake under unsafe engine operating conditions.

Failure Mode Identifier (FMI) – The FMI describes the type of failure that was experienced by the component. The codes for the FMI were adopted from the standard practices of SAE (J1587 diagnostics).

Flash Memory – See the Personality Module.

Fuel Ratio Control (FRC) – The FRC is a limit that is based on the control of the fuel to air ratio. The FRC is used for emission control. When the ECM senses a higher turbocharger outlet pressure, the ECM increases the limit for the FRC in order to allow more fuel into the cylinders.

Fuel Position – The fuel position is a signal within the ECM. The signal is from the electronic governor. The signal goes to the fuel injection control. The signal is based on the desired engine speed, the FRC, the rated position, and the actual engine speed.

Harness – The harness is the bundle of wiring that connects all the components of the electrical engine system.

Hertz (Hz) – Hz is the measure of frequency in cycles per second.

High Pressure Oil Manifold – The high pressure oil manifold is an oil gallery that is added to the cylinder head in order to supply the unit injectors with high pressure oil.

High Pressure Oil Pump – The high pressure oil pump is an axial piston pump that is driven by gears. The high pressure oil pump is used to raise the engine oil pressure in order to activate the unit injectors. The amount of oil pressure that is required to activate the unit injectors is called the actuation pressure.

Hydraulic Electronic Unit Injector System (HEUI) – The HEUI is a fuel system that uses a hydraulically actuated, electronically controlled unit injector. The system combines the pumping, electronic fuel metering and injecting elements in a single unit.

Injection Actuation Pressure Control Valve (IAP Control Valve) – The injection actuation pressure control valve is a variable valve. The valve is used to maintain the proper oil pressure in the engine high pressure oil gallery. The valve is controlled by the ECM.

Injection Actuation Pressure Sensor (IAP) – The injection actuation pressure sensor is a sensor that measures hydraulic oil pressure. The sensor also sends a signal to the ECM.

Inlet Air Temperature Sensor – The inlet air temperature sensor is a sensor that measures the inlet air temperature. The sensor also sends a signal to the electronic control module (ECM).

Open Circuit – An open circuit is a broken electrical wire connection. The signal or the supply voltage cannot reach the intended destination.

Original Equipment Manufacturer (OEM) – An OEM is the manufacturer of a vehicle that utilizes a Caterpillar engine.

Parameter – A parameter is a programmable value which affects the characteristics or the behavior of the engine and/or vehicle.

Parameter Identifier (PID) – A PID is a numerical code that contains two digits or three digits. A numerical code is assigned to each component. The numerical code identifies data via the data link to the ECM.

Password – A password is a group of numeric characters or alphanumeric characters. A password is designed to restrict the changing of information in the ECM. The electrical engine systems require correct customer passwords in order to change customer specified parameters. The electrical engine systems require correct factory passwords in order to clear certain logged events. Factory passwords are also required in order to change certain engine specifications.

Personality Module – The personality module is the module in the ECM which contains all the instructions (software) for the ECM and performance maps for a specific horsepower family. Updates and rerates are accomplished by electronically flashing in new data. The updates and rerates are flashed in using an electronic service tool.

Power Take-Off (PTO) – The PTO is operated with the cruise control switches or dedicated PTO inputs. This mode of operation permits setting constant engine rpm when the vehicle is not moving or when the vehicle is moving at slow speeds.

Progressive Shifting – Progressive shifting is upshifting through the lower gears quickly. Shifts are made above peak torque but below rated rpm. Needless to say, operating the engine in the higher rpm ranges before shifting to the next gear wastes fuel. Also, this mode of operation fails to take advantage of the torque rise of the engine.

Pulse Width Modulation (PWM) – A PWM is a digital type of electronic signal that corresponds to a measured variable. The length of the pulse (signal) is controlled by the measured variable. The variable is quantified by a certain ratio. This ratio is the percent of “on-time” that is divided by the percent of “off-time”. A PWM signal is generated by the Throttle Position Sensor.

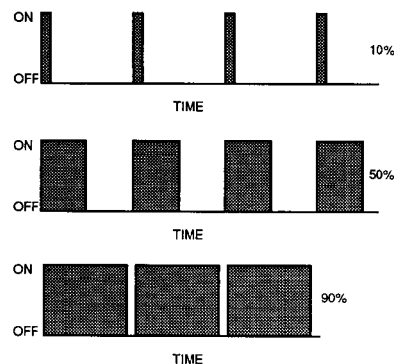

Illustration 4

g00284479

Example Of Pulse Width Modulation

Rated Fuel Position (“Rated Fuel Pos” on ECAP) – The rated fuel position indicates the maximum allowable fuel position (longest injection pulse). The rated fuel position will produce rated power for this engine configuration.

Reference Voltage – The reference voltage is a regulated voltage that is used by the sensor in order to generate a signal voltage.

Sensor – A sensor is used to detect a change in the pressure, in the temperature, or in mechanical movement. When any of these changes are detected, a sensor converts the change into an electrical signal.

Service Program Module (SPM) – The SPM is a software program on a computer chip that was programmed at the factory. The computer chip is designed to adapt an ECAP for a particular application.

Short Circuit – A short circuit is an electrical circuit that is mistakenly connected to an undesirable point. For example, an electrical contact is made with the frame whenever an exposed wire rubs against a vehicle’s frame.

Signal – A signal is a voltage or a wave that is used to transmit information that is typically from a sensor to the ECM.

Speed Burp – A speed burp is a sudden brief change in engine rpm.

Speed-timing Sensor – The speed-timing sensor is a sensor that provides a Pulse Width Modulated signal to the ECM. The ECM interprets this signal as the crankshaft position and the engine speed.

Subsystem – A subsystem is a part of the engine system that relates to a particular function.

Supply Voltage – Supply voltage is a constant voltage that is supplied to a component in order to provide electrical power for operation. Supply voltage may be generated by the ECM. Supply voltage may also be the battery voltage of the vehicle that is supplied by the vehicle wiring.

“T” Harness – This harness is a test harness that is designed to permit normal circuit operation and the measurement of the voltage simultaneously. Typically, the harness is inserted between the two ends of a connector.

Throttle Position – The ECM interprets a signal that is sent from the throttle position sensor in order to determine the throttle position. The throttle position may be used as part of a power take-off control.

Total Tattletale – The total tattletale is the total number of changes to all system parameters.

Transducer – A transducer is a device that converts a mechanical signal to an electrical signal.

Vehicle Speed Sensor – A vehicle speed sensor is an electromagnetic pickup that measures vehicle speed from the rotation of gear teeth in the drive train of the vehicle.

i01748266

Electronic Control System Components

SMCS Code: 1900

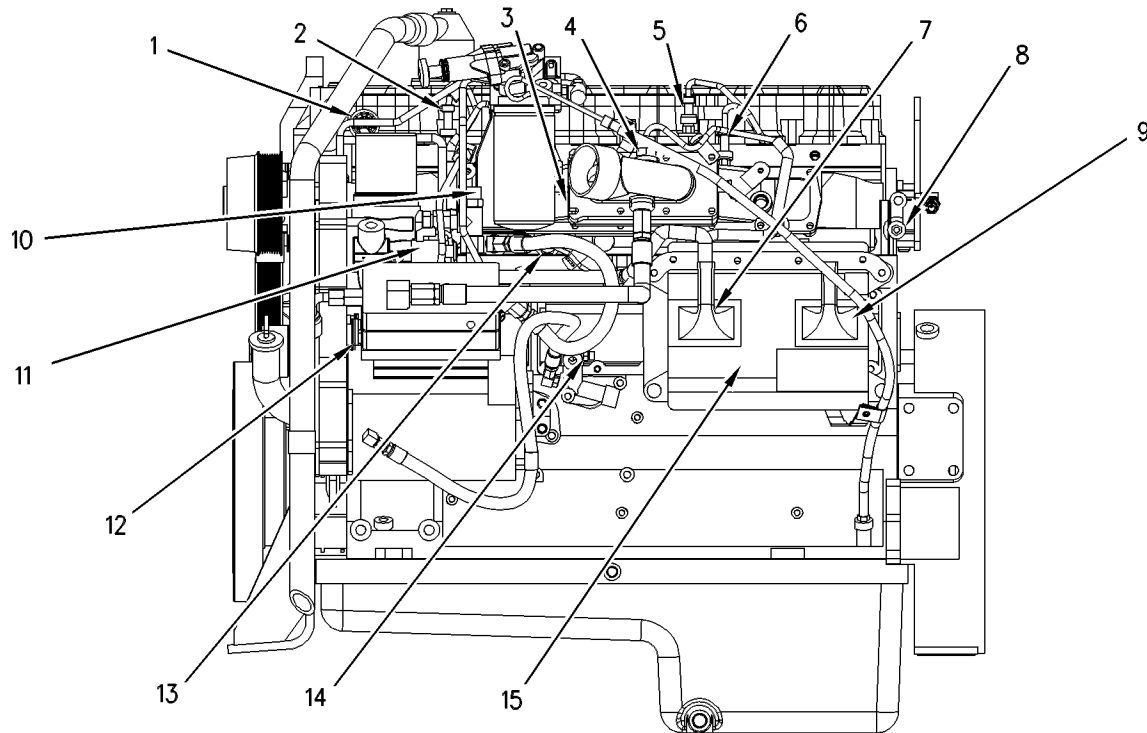

Illustration 5

g00292549

Electronic control system components (left side view)

- | | | |
|---|---|--|
| (1) Grommet for injector harness | (7) Engine harness connector J2/P2 | (13) Coolant temperature sensor |
| (2) Injection actuation pressure sensor | (8) Engine ground stud connection | (14) Oil pressure sensor (if equipped) |
| (3) Air inlet heater | (9) Vehicle harness connector J1/P1 | (15) Engine Control Module (ECM) |
| (4) Inlet air temperature sensor | (10) Oil temperature sensor (if equipped) | |
| (5) Atmospheric pressure sensor (if equipped) | (11) Injection actuation pressure control valve | |
| (6) Boost pressure sensor | (12) Engine speed/timing sensors | |

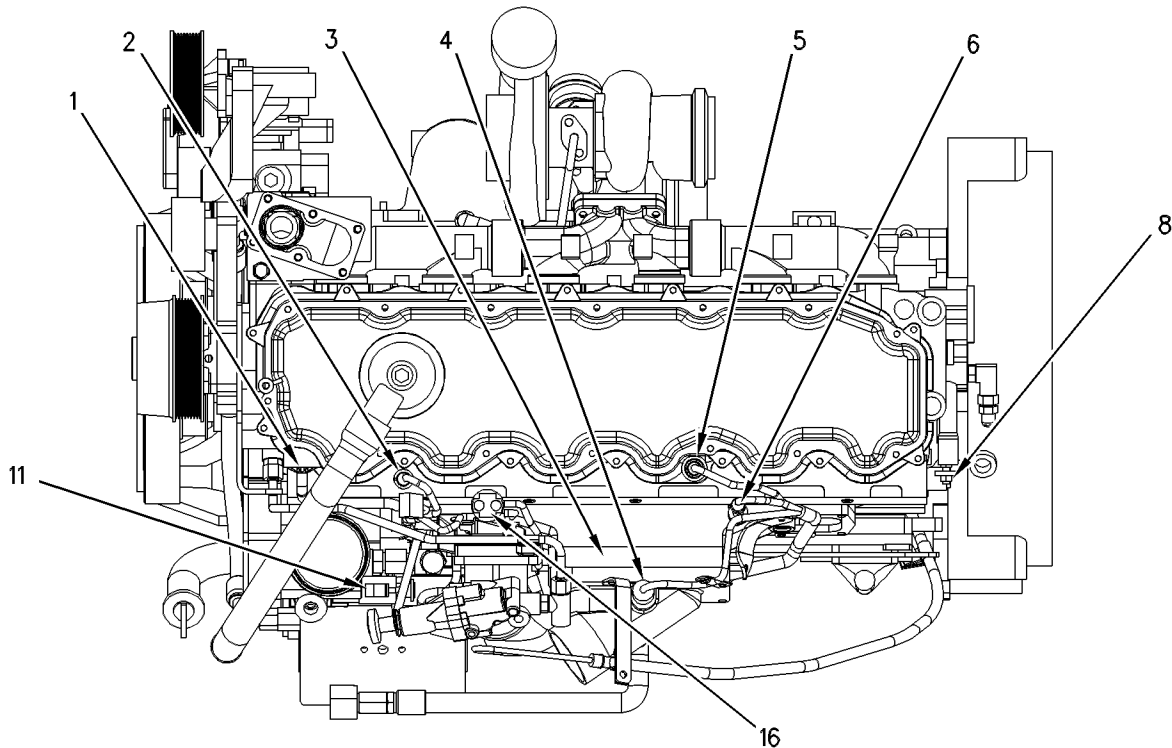

Illustration 6

g00292594

Electronic control system components (top view)

- | | | |
|---|---|---|
| (1) Grommet for injector harness | (5) Atmospheric pressure sensor (if equipped) | (11) Injection actuation pressure control valve |
| (2) Injection actuation pressure sensor | (6) Boost pressure sensor | (16) Relay for the air inlet heater |
| (3) Air inlet heater | (8) Engine ground stud connection | |
| (4) Inlet air temperature sensor | | |

The electronic control system is integrally designed into the engine's fuel system and the engine's air inlet and exhaust system in order to electronically control the fuel delivery and the injection timing. The electronic control system provides increased timing control and fuel air ratio control in comparison to conventional mechanical engines. Injection timing is achieved by the precise control of the injector firing time. Engine rpm is controlled by adjusting the injection duration. The Engine Control Module (ECM) energizes the unit injector solenoids in order to start the injection of fuel. Also, the Engine Control Module (ECM) de-energizes the unit injector solenoids in order to stop the injection of fuel.

Refer to Systems Operation/Testing And Adjusting, "HEUI Injector Operation" for a complete explanation of the fuel injection process.

The engine uses the following three types of electronic components:

- Input component
- Control component

- Output component

An input component is one that sends an electrical signal to the ECM of the system. The signal that is sent varies in either of the following ways:

- Voltage
- Frequency
- Pulse width

The variation of the signal is in response to a change in some specific system of the vehicle. Some specific examples of an input component are the engine speed-timing sensors, the coolant temperature sensor, and the cruise control switches. The ECM interprets the signal from the input component as information about the condition, environment, or operation of the vehicle.

A control component (ECM) receives the input signals from the input components. Electronic circuits inside the control component evaluate the signals from the input components. These electronic circuits also supply electrical energy to the output components of the system. The electrical energy that is supplied to the output components is based on predetermined combinations of input signal values.

An output component is one that is operated by a control module. The output component receives electrical energy from the control group. The output component uses that electrical energy in one of two ways. The output component can use that electrical energy in order to perform work. The output component can use that electrical energy in order to provide information.

As an example, a moving solenoid plunger will perform work. By performing work, the component has functioned in order to regulate the vehicle.

As an example, a dash panel light or an alarm will provide information to the operator of the vehicle.

These electronic components provide the ability to electronically control the engine operation. Engines with electronic controls offer the following advantages:

- Improvement in performance
- Improvement in fuel consumption
- Reduction in emissions levels

Table 1

Electrical Connectors And Functions	
Connector	Function
J1/P1	ECM Connector (70-Pin OEM Harness)
J2/P2	ECM Connector (70-Pin, Engine Harness)
J100/P100	Coolant Temperature Sensor (2-Pin Connector)
J103/P103	Inlet Manifold Air Temperature Sensor (2-Pin Connector)
J200/P200	Boost Pressure Sensor (3-Pin Connector)
J203/P203	Atmospheric Pressure Sensor (3-Pin Connector)
J204/P204	Injection Actuation Pressure Sensor (3-Pin Connector)
J300/P300	Injection Solenoid Harness (12-Pin Connector)
J301/P301	No. 1 Unit Injector Solenoid (2-Pin Connector)
J302/P302	No. 2 Unit Injector Solenoid (2-Pin Connector)
J303/P303	No. 3 Unit Injector Solenoid (2-Pin Connector)
J304/P304	No. 4 Unit Injector Solenoid (2-Pin Connector)
J305/P305	No. 5 Unit Injector Solenoid (2-Pin Connector)
J306/P306	No. 6 Unit Injector Solenoid (2-Pin Connector)
J400/P400	Engine Timing Calibration Probe (2-Pin Connector)
J401/P401	Top Camshaft Speed/Timing Sensor (2-Pin Connector)
J402/P402	Bottom Camshaft Speed/Timing Sensor (2-Pin Connector)
J403/P403	Accelerator Pedal Position Sensor (3-Pin Connector)
J500/P500	Injection Actuation Pressure Control Valve (2-Pin Connector)
J501/P501	Air Inlet Heater Relay (2-Pin Connector)
J648/P648	Air Inlet Heater Lamp (2-Pin Connector)

Table 2

Diagnostic Flash Codes		
PID-FMI	Flash Code	Description of Code
1-11	72	Cylinder 1 Fault
2-11	72	Cylinder 2 Fault
3-11	73	Cylinder 3 Fault

(continued)

(Table 2, contd)

Diagnostic Flash Codes		
PID-FMI	Flash Code	Description of Code
4-11	73	Cylinder 4 Fault
5-11	74	Cylinder 5 Fault
6-11	74	Cylinder 6 Fault
22-13	42	Check Timing Sensor Calibration
30-08	29	Invalid PTO Throttle Signal
30-13	29	PTO Throttle Sensor Calibration
41-03	21	8 Volt Supply Above Normal
41-04	21	8 Volt Supply Below Normal
42-11	18	Injection Actuation Pressure Control Valve Driver Fault
43-02	71	Ignition Keyswitch Fault
64-02	34	Loss of Engine RPM Signal on Engine Speed and Timing Sensor Number 2
64-11	34	No Pattern on Engine Speed and Timing Sensor Number 2
70-05	49	Air Inlet Heater Open Circuit
70-06	49	Air Inlet Heater Short Circuit
71-00	01	Idle Shutdown Override
71-01	47	Idle Shutdown Occurrence
71-14	47	PTO Shutdown Timer Occurrence
84-00	41	Vehicle Overspeed Warning
84-01	31	Loss of Vehicle Speed Signal
84-02	36	Invalid Vehicle Speed Signal
84-08	36	Vehicle Speed Out of Range
84-10	36	Vehicle Speed Rate of Change
91-08	32	Invalid Throttle Signal
91-13	28	Throttle Sensor Calibration
100-03	24	Open Circuit of Oil Pressure Sensor
100-04	24	Short Circuit of Oil Pressure Sensor
100-11	46	Very Low Oil Pressure
102-03	25	Boost Pressure Sensor Open Circuit
102-04	25	Boost Pressure Sensor Short Circuit
105-03	38	Inlet Manifold Air Temperature Sensor Open Circuit
105-04	38	Inlet Manifold Air Temperature Sensor Short Circuit
108-03	26	Atmospheric Pressure Sensor Open Circuit

(Table 2, contd)

Diagnostic Flash Codes		
PID-FMI	Flash Code	Description of Code
108-04	26	Atmospheric Pressure Sensor Short Circuit
110-00	61	High Coolant Temperature Warning
110-03	27	Coolant Temperature Sensor Open Circuit
110-04	27	Coolant Temperature Sensor Short Circuit
110-11	61	Very High Coolant Temperature
111-01	62	Low Coolant Level Warning
111-02	12	Coolant Level Sensor Fault
111-11	62	Very Low Coolant Level
164-00	17	Injection Actuation Pressure Out of Range
164-02	15	Injection Actuation Pressure Sensor Erratic
164-03	15	Injection Actuation Pressure Open Circuit
164-04	15	Injection Actuation Pressure Short Circuit
164-11	39	Injection Actuation Pressure System
168-02	51	Intermittent Battery Power to the ECM
190-00	35	Engine Overspeed Warning
190-02	34	Loss of RPM Signal on Engine Speed and Timing Sensor Number 1
190-11	34	No Pattern on Engine Speed and Timing Sensor Number 1
231-11	58	J1939 Data Link Fault
232-03	21	5 Volt Supply Above Normal
232-04	21	5 Volt Supply Below Normal
246-11	00	Service Brake Switch Number 1 Fault
247-11	00	Service Brake Switch Number 2 Fault
252-11	59	Incorrect Engine Software
253-02	59	Check Customer or System Parameters

i01750138

Fuel System

SMCS Code: 1250

(continued)

Introduction

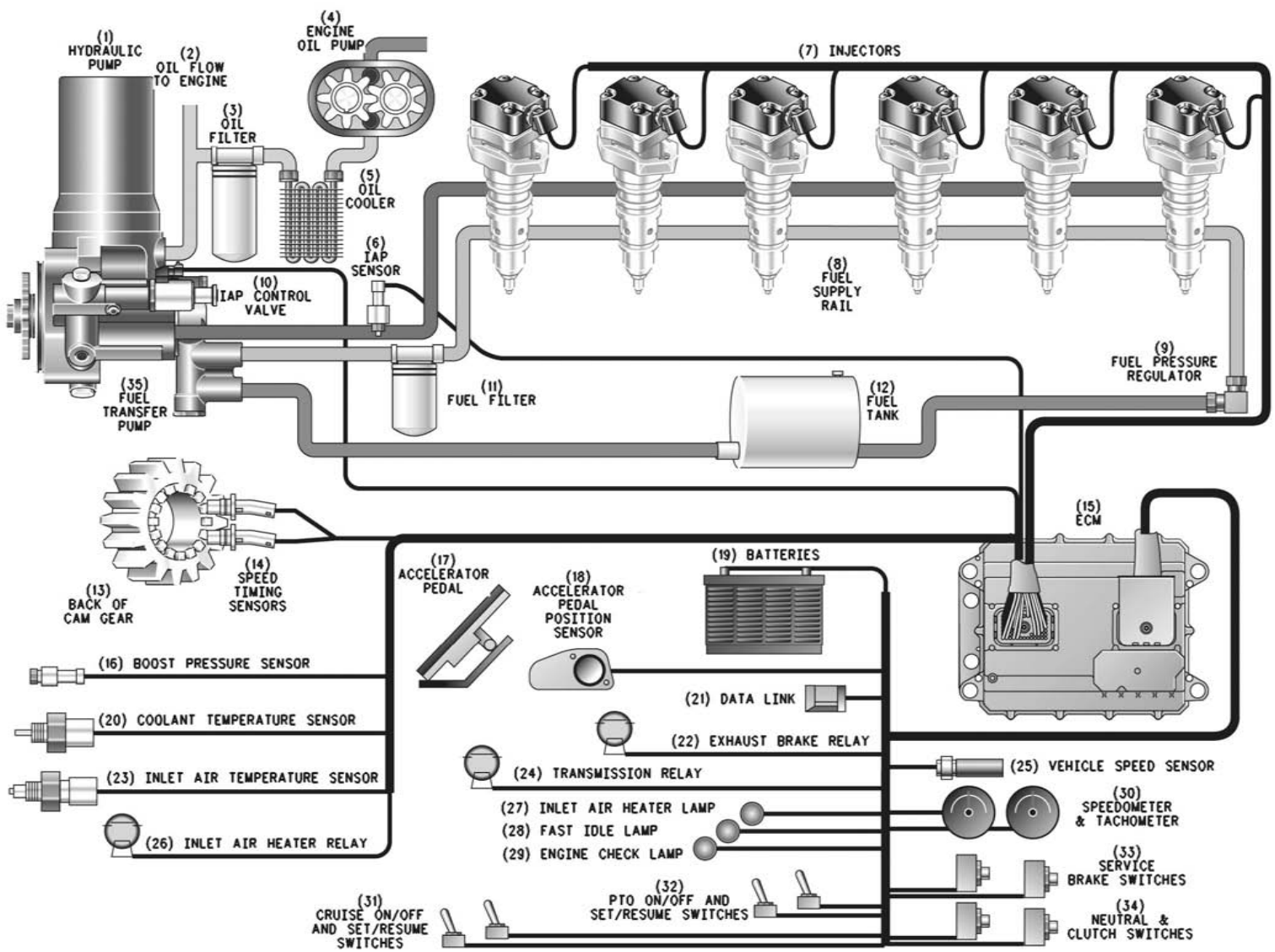

Illustration 7
Diagram of components for the HEUI fuel system

g000457847

- | | | |
|----------------------------------|--|--|
| (1) Unit injector hydraulic pump | (14) Speed/timing sensors | (27) Inlet air heater lamp |
| (2) Oil flow to engine | (15) ECM | (28) Fast idle lamp |
| (3) Oil filter | (16) Boost pressure sensor | (29) Check engine lamp |
| (4) Engine oil pump | (17) Accelerator pedal | (30) Speedometer and tachometer |
| (5) Oil cooler | (18) Accelerator pedal position sensor | (31) Cruise ON/OFF switch and Cruise SET/RESUME switch |
| (6) IAP sensor | (19) Batteries | (32) PTO ON/OFF switch and SET/RESUME switch |
| (7) Injectors | (20) Coolant temperature sensor | (33) Service brake switches |
| (8) Fuel supply rail | (21) Data link | (34) Neutral and clutch switches |
| (9) Fuel pressure regulator | (22) Exhaust brake relay | (35) Fuel transfer pump |
| (10) IAP control valve | (23) Inlet air temperature sensor | |
| (11) Fuel filter | (24) Transmission relay | |
| (12) Fuel tank | (25) Vehicle speed sensor | |
| (13) Back of cam gear | (26) Inlet air heater relay | |

The operation of the Hydraulic Electronic Unit Injector (HEUI) fuel system is completely different from any other type of fuel system that is actuated mechanically. The HEUI fuel system is completely free of adjustment. Adjustments to the components that are mechanical can not be made. Changes in performance are made by installing different software in Engine Control Module (ECM) (15).

This fuel system consists of six basic components:

- Hydraulic Electronic Unit Injector (HEUI) (7)
- Engine Control Module (ECM) (15)
- Unit injector hydraulic pump (1)
- Injection Actuation Pressure Control Valve (10)
- Fuel Transfer Pump (35)
- Injection Actuation Pressure Sensor (6)

Note: The components of the HEUI fuel system are not serviceable. These fuel system components must not be disassembled. Disassembly will damage the components. If the components have been disassembled, Caterpillar may not allow a warranty claim or Caterpillar may reduce the warranty claim.

Component Description

Hydraulic Electronic Unit Injector

The HEUI fuel system utilizes a hydraulically actuated electronically controlled unit injector (7).

All fuel systems for diesel engines use a plunger and barrel in order to pump fuel under high pressure into the combustion chamber. This fuel is pumped into the combustion chamber in precise amounts in order to control engine performance. The HEUI uses engine oil under high pressure in order to power the plunger. All other fuel systems use a fuel injection pump camshaft lobe in order to power the plunger. Because the HEUI is much different, a technician must use different troubleshooting methods.

The HEUI uses engine lubrication oil that is pressurized from 6 MPa (870 psi) to 27.5 MPa (4000 psi) in order to pump fuel from the injector. The HEUI operates in the same way as a hydraulic cylinder in order to multiply the force of the high pressure oil. By multiplying the force of the high pressure oil, the HEUI can produce injection pressures that are very high. This multiplication of pressure is achieved by applying the force of the high pressure oil to a piston. The piston is larger than the plunger by approximately six times. The piston that is powered by engine lubrication oil under high pressure pushes on the plunger. This engine lubrication oil under high pressure is called the actuation pressure of the oil. The actuation pressure of the oil generates the injection pressure that is delivered by the unit injector. Injection pressure is greater than actuation pressure of the oil by approximately six times.

Low actuation pressure of the oil results in low injection pressure of the fuel. During conditions of low speed such as idle and start, low injection pressure is utilized.

High actuation pressure of the oil results in high injection pressure of the fuel. During conditions of high speed such as high idle and acceleration, high injection pressure is utilized.

There are many other operating conditions when the injection pressure is between the minimum and the maximum. Regardless of the speed of the engine, the HEUI fuel system provides infinite control of injection pressure.

Engine Control Module (ECM)

Engine Control Module (ECM) (15) is located on the left side of the engine. The ECM is a powerful computer that provides total electronic control of engine performance. The ECM uses data from engine performance that is gathered by several sensors. Then, the ECM uses this data in order to make adjustments to the fuel delivery, injection pressure and injection timing. The ECM contains programmed performance maps (software) in order to define horsepower, torque curves and rpm. This software is commonly called the personality module.

Some engines use Engine Control Modules (ECM) (15) with a replaceable computer chip. The software has already been installed in the replaceable computer chip. The 3126B and 3126E diesel truck engines do not have a replaceable personality module. The 3126B and 3126E diesel truck engine's personality module are a permanent part of the ECM. The 3126B and 3126E diesel truck engine's personality module can be reprogrammed. Reprogramming of the personality module requires the use of Caterpillar Electronic Technician (Cat ET). The flash function of Cat ET will be used during the reprogramming.

ECM (15) logs faults of engine performance. Also, the ECM is capable of running several diagnostic tests automatically when the ECM is used with an electronic service tool such as the Cat ET.

Unit injector hydraulic pump

Unit injector hydraulic pump (1) (high pressure oil pump) is located at the left front corner of the engine. The unit injector hydraulic pump is a piston pump that has a fixed displacement. The unit injector hydraulic pump uses an axial piston. The unit injector hydraulic pump uses a portion of the engine lubrication oil. The unit injector hydraulic pump pressurizes the engine lubrication oil to the injection actuation pressure that is required in order to power the HEUI injectors.

Injection Actuation Pressure Control Valve (IAP Control Valve)

Injection actuation pressure control valve (10) (IAP Control Valve) is located on the side of unit injector hydraulic pump (1). Under most conditions, the pump is producing excess oil flow. The IAP Control Valve discharges excess pump flow to the drain in order to control injection actuation pressure to the desired level. The IAP Control Valve is a valve of high precision that controls the actual actuation pressure. The performance maps of ECM (15) contain a desired actuation pressure for every engine operating condition. The ECM sends a control current to the IAP Control Valve. The control current should make the actual actuation pressure equal to the desired actuation pressure.

IAP Control Valve (10) is an actuator. The IAP Control Valve converts an electrical signal from ECM (15) to the mechanical control of a spool valve in order to control pump outlet pressure.

Fuel Transfer Pump

Fuel transfer pump (35) is mounted on the back of unit injector hydraulic pump (1). The fuel transfer pump is used in order to draw fuel from fuel tank (12). Also, the fuel transfer pump is used in order to pressurize the fuel to 450 kPa (65 psi). The pressurized fuel is supplied to injectors (7).

Fuel transfer pump (35) is a single piston pump that is spring loaded. The shaft of the unit injector hydraulic pump provides power to the transfer pump through an off-center bearing. There are two check valves in the fuel transfer pump. The inlet check valve opens in order to allow fuel from the tank into the pump. The inlet check valve closes in order to prevent fuel leakage back to the fuel tank. The outlet check valve opens in order to supply fuel to the fuel supply passage. The fuel supply passage is located in the cylinder head. The fuel supply passage supplies fuel to injectors (7). The outlet check valve closes in order to prevent pressurized fuel leakage back through the pump.

Injection Actuation Pressure Sensor (IAP)

IAP Sensor (6) is installed in the high pressure oil manifold. The high pressure oil manifold supplies actuation oil in order to power the unit injectors. The IAP Sensor monitors injection actuation pressure. The IAP Sensor sends a continuous voltage signal back to ECM (15). The ECM interprets the signal. The ECM is aware of the injection actuation pressure at all times.

HEUI Fuel System Operation

Low Pressure Fuel System

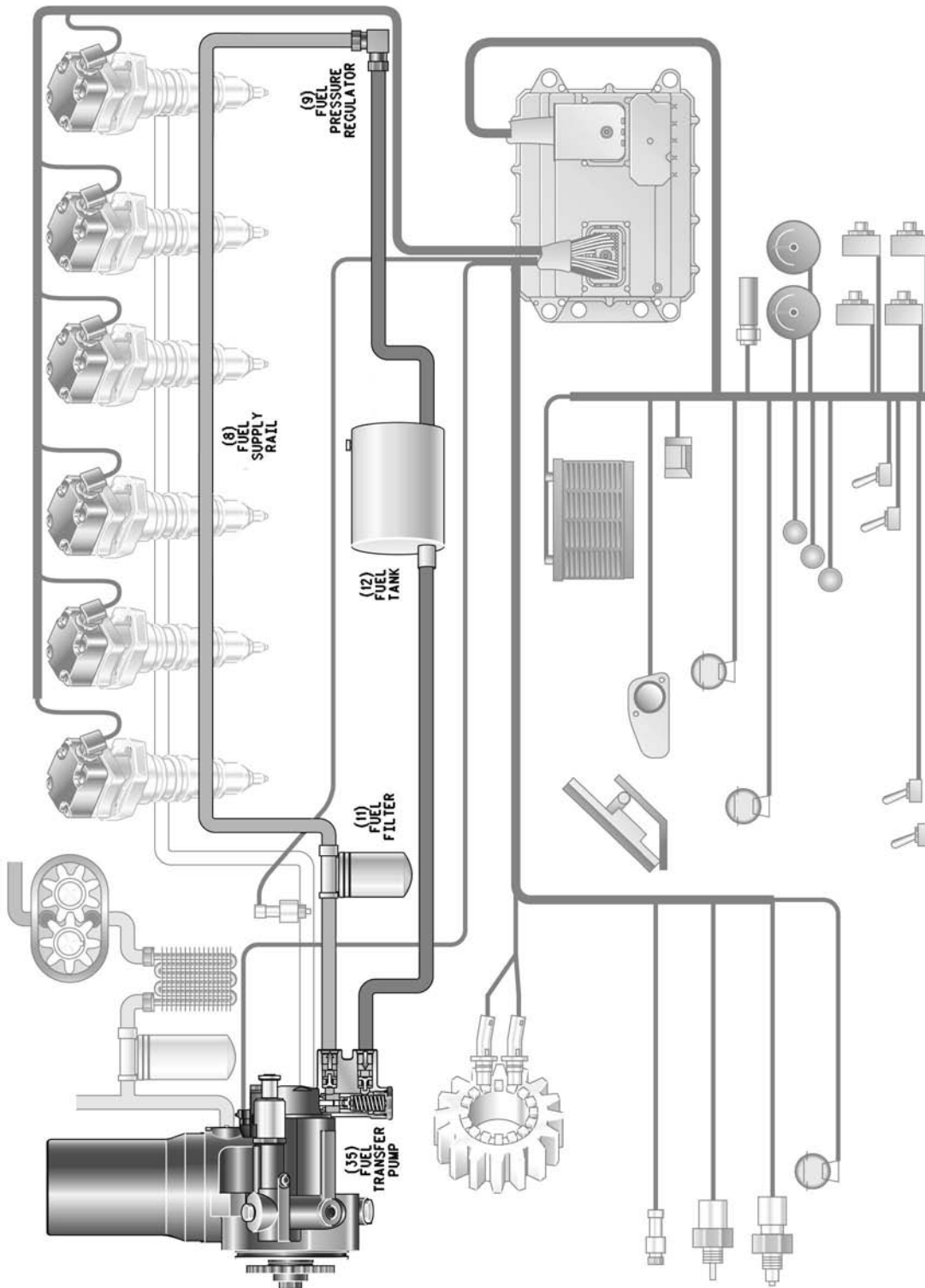

Illustration 8
Low pressure fuel system

(8) Fuel supply line
(9) Fuel pressure regulator

(11) Fuel filter
(12) Fuel tank

(35) Fuel transfer pump

The low pressure fuel system serves three functions. The low pressure fuel system supplies fuel for combustion to injectors (7). Also, the low pressure fuel system supplies excess fuel flow in order to cool the unit injectors and the low pressure fuel system supplies excess fuel flow in order to remove air from the system.

The low pressure fuel system consists of four basic components:

- Fuel pressure regulator (9)
- Fuel filter (11)
- Fuel tank (12)
- Fuel transfer pump (35)

Fuel transfer pump (35) is mounted on the back of unit injector hydraulic pump (1). The fuel transfer pump pushes pressurized fuel out of the outlet port and the fuel transfer pump draws new fuel into the inlet port.

Fuel is drawn from fuel tank (12) and flows through two micron fuel filter (11).

Fuel flows from fuel filter (11) to the inlet side of fuel transfer pump (35). An inlet check valve in the inlet port of the fuel transfer pump opens in order to allow the flow of fuel into the pump. After the fuel flow has stopped, the inlet check valve closes in order to prevent fuel flow out of the inlet port. Fuel flows from the inlet port in the pump to the outlet port, which also has a check valve. The outlet check valve opens in order to allow pressurized fuel flow out of the pump. The outlet check valve closes in order to prevent pressurized fuel leakage back through the pump.

Fuel flows from the outlet port of fuel transfer pump (35) to the fuel supply passage in the cylinder head. The fuel supply passage is a drilled hole which begins at the front of the cylinder head. The fuel supply passage extends to the back of the cylinder head. This passage connects with each unit injector bore in order to supply fuel to unit injectors (7). Fuel from the transfer pump flows through the cylinder head to all of the unit injectors. Excess fuel flows out of the back of the cylinder head. After the excess flows out of the back of the cylinder head, the fuel flows into fuel pressure regulator (9).

Fuel pressure regulator (9) consists of an orifice and a spring loaded check valve. The orifice is a flow restriction that pressurizes the supply fuel. The spring loaded check valve opens at 35 kPa (5 psi) in order to allow the fuel which has flowed through the orifice to return to fuel tank (12). When the engine is off and no fuel pressure is present, the spring loaded check valve closes. The spring loaded check valve closes in order to prevent the fuel in the cylinder head from draining back to the fuel tank.

Injection Actuation System

Actuation Oil Flow

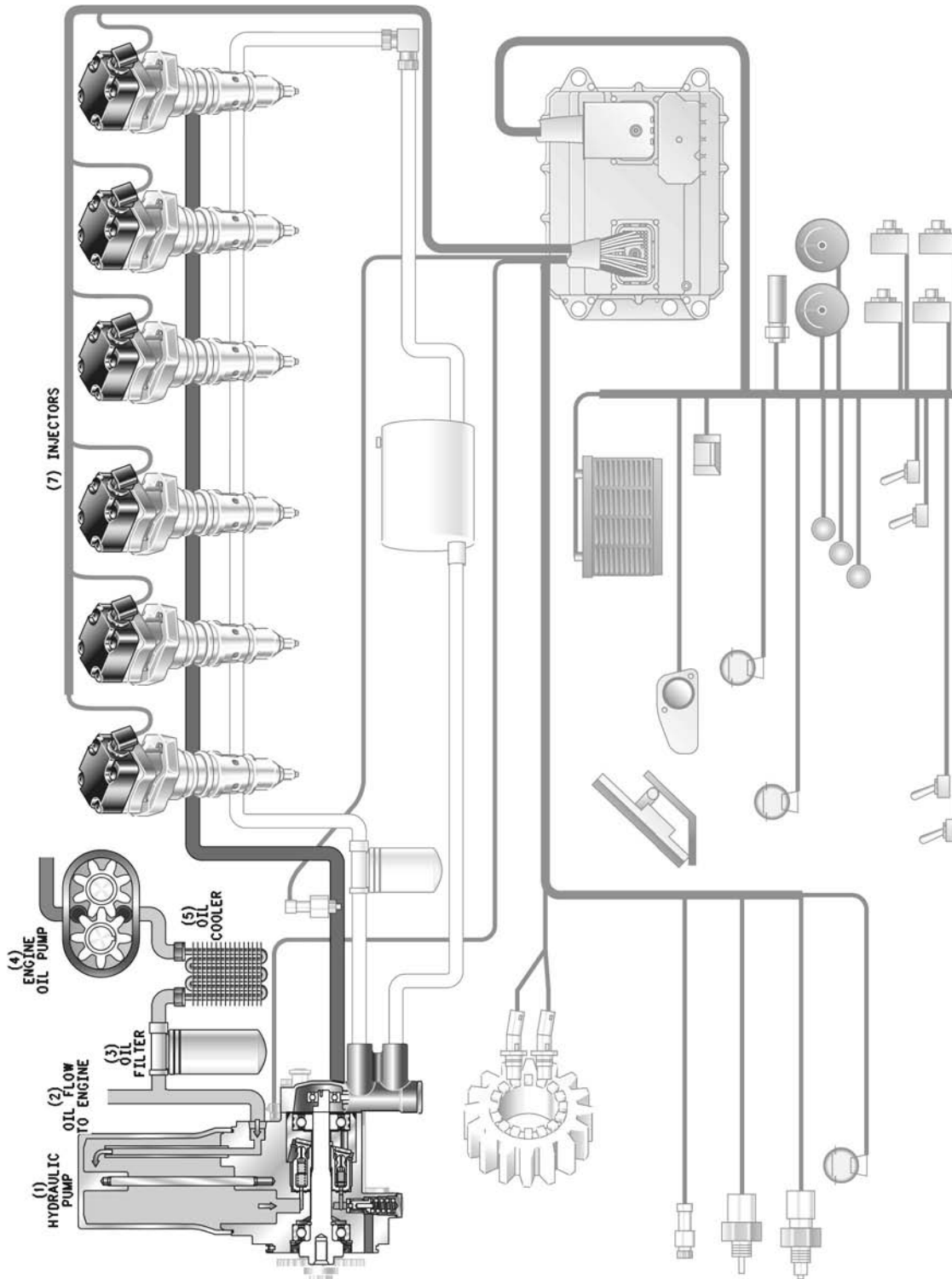

Illustration 9

Flow path of the injection actuation oil

(1) Unit injector hydraulic pump
(2) Oil flow to engine

(3) Oil filter
(4) Engine oil pump

(5) Oil cooler
(7) Injectors

The injection actuation system serves two functions. The injection actuation system supplies high pressure oil in order to power HEUI injectors (7). Also, the injection actuation system controls the injection pressure that is produced by the unit injectors by changing the actuation pressure of the oil.

The injection actuation system consists of five basic components:

- Engine oil pump (4)
- Engine oil filter (3)
- Unit injector hydraulic pump (1)
- Injection actuation pressure control valve (IAP Control Valve) (10)
- Injection actuation pressure sensor (IAP Sensor) (6)

Oil from engine oil pump (4) supplies the needs of the engine lubrication system. Also, oil from the engine oil pump supplies the needs of unit injector hydraulic pump (1) for the fuel system. The capacity of the engine oil pump has been increased in order to meet the additional flow requirement that is necessary.

Oil that is drawn from the sump is pressurized to the lubrication system oil pressure by engine oil pump (4). Oil flows from the engine oil pump through engine oil cooler (5), through engine oil filter (3), and then to the main oil gallery. A separate circuit from the main oil gallery directs a portion of the lubrication oil in order to supply unit injector hydraulic pump (1). A steel tube on the left side of the engine connects the main oil gallery with the inlet port of the unit injector hydraulic pump.

Oil flows into the inlet port of unit injector hydraulic pump (1) and the oil fills the pump reservoir. The pump reservoir provides oil to the unit injector hydraulic pump during start-up. Also, the pump reservoir provides oil to the unit injector hydraulic pump until the engine oil pump can increase pressure.

The pump reservoir also provides makeup oil to the high pressure oil passage in the cylinder head. When the engine is off and the engine cools down, the oil shrinks. A check valve in the pump allows oil to be drawn from the pump reservoir in order to keep the high pressure oil passage full.

Oil from the pump reservoir is pressurized in unit injector hydraulic pump (1) and the oil is pushed out of the outlet port of the pump under high pressure. Oil then flows from the outlet port of the unit injector hydraulic pump to the high pressure oil passage in the cylinder head.

The high pressure oil passage connects with each unit injector bore in order to supply high pressure actuation oil to unit injectors (7). Actuation oil that is under high pressure flows from unit injector hydraulic pump (1) through the cylinder head to all of the injectors. Oil is contained in the high pressure oil passage until the oil is used by the unit injectors. Oil that has been exhausted by the unit injectors is expelled under the valve covers. This oil returns to the crankcase through oil drain holes in the cylinder head.

Actuation Oil Pressure Control

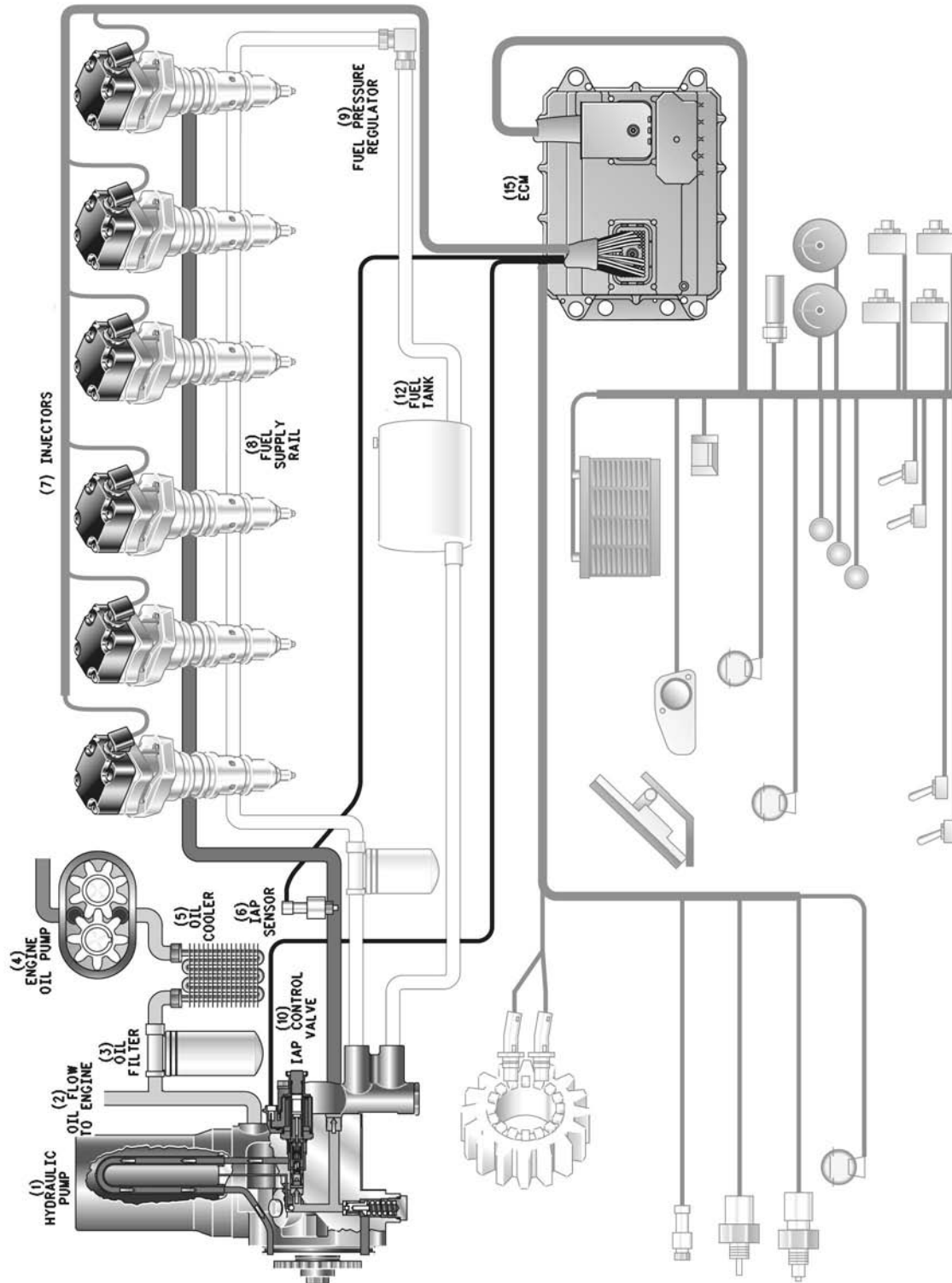

Illustration 10

Injection Actuation Oil Pressure Control

- (1) Unit injector hydraulic pump
- (2) Oil flow to engine
- (3) Oil filter
- (4) Engine oil pump

- (5) Oil cooler
- (6) IAP sensor
- (7) Injectors
- (8) Fuel supply rail

- (9) Fuel pressure regulator
- (10) IAP control valve
- (12) Fuel tank
- (15) ECM

Unit injector hydraulic pump (1) is a fixed displacement axial piston pump. The pump is designed in order to generate adequate flow under the conditions that are the most demanding.

Under most operating conditions, unit injector hydraulic pump (1) is producing excess flow. This excess flow must be discharged to a drain in order to control the system's pressure. IAP Control Valve (10) regulates system pressure by discharging the precise amount of oil to the drain. This discharging of oil is required in order to maintain the desired actuation pressure.

There are two types of actuation pressure:

- Desired actuation pressure
- Actual actuation pressure

Desired actuation pressure is the injection actuation pressure that is required by the system for optimum engine performance. The desired actuation pressure is established by the performance maps in ECM (15). The ECM selects the desired actuation pressure. The ECM bases the selection on the signal inputs from many sensors. Some of the sensors that are supplying signal inputs to the ECM are accelerator pedal position sensor (18), boost pressure sensor (16), speed/timing sensors (14), and coolant temperature sensor (20). The desired actuation pressure is constantly changing due to changing engine speed and due to changing engine load. The desired actuation pressure is only constant under steady state conditions (steady engine speed and load).

Actual actuation pressure is the actual system pressure of the actuation oil that is powering the injectors (7). IAP Control Valve (10) is constantly changing the amount of pump flow that is discharged to the drain. The pump flow is discharged to the drain in order to match the actual actuation pressure to the desired actuation pressure.

Three components operate together in order to control injection actuation pressure:

- ECM (15)
- IAP Control Valve (10)
- IAP Sensor (6)

ECM (15) selects the desired actuation pressure. The desired actuation pressure is based on both the sensor input and the performance maps. The ECM sends a control current to IAP Control Valve (10) in order to change the actual actuation pressure. The IAP Control Valve reacts to the electrical current from the ECM in order to change the actual actuation pressure. The actual actuation pressure is changed when the IAP Control Valve discharges pump flow to the drain. The IAP Control Valve acts as an electrically controlled relief valve. IAP Sensor (6) monitors the actual actuation pressure in the high pressure oil passage. The IAP Sensor reports the actual actuation pressure to the ECM by sending a signal voltage to the ECM.

The injection actuation pressure control system operates in a cycle. ECM (15) selects the desired actuation pressure. Then, the ECM sends an electrical current to IAP Control Valve (10) that should produce that pressure. The IAP Control Valve reacts to the electrical current from the ECM by changing the pressure relief setting, which changes the actual actuation pressure. IAP Sensor (6) monitors the actual actuation pressure and the IAP Sensor sends a signal voltage back to the ECM. The ECM interprets the signal voltage from the IAP Sensor in order to calculate the actual actuation pressure. Then, the ECM compares the actual actuation pressure to the desired actuation pressure in order to adjust the electrical current to the IAP Control Valve. The IAP Control Valve responds to the change in electrical current by changing the actual actuation pressure. This process is repeated 67 times per second. This cycle of constant repetition is called a closed loop control system.

Most of the high pressure oil flow from unit injector hydraulic pump (1) is used in order to power unit injectors (7). Excess flow is the amount of pump flow that is not required in order to meet the desired actuation pressure. The excess flow is returned to the drain through IAP Control Valve (10). Excess flow from the IAP Control Valve flows upward through a U-shaped tube in the pump reservoir. The excess flow travels through a drilled passage to the front of the pump. Drain oil flows out of the front of the pump over the pump drive gear and flows down the engine front gear train to sump.

Operation of the Injection Actuation Pressure Control Valve

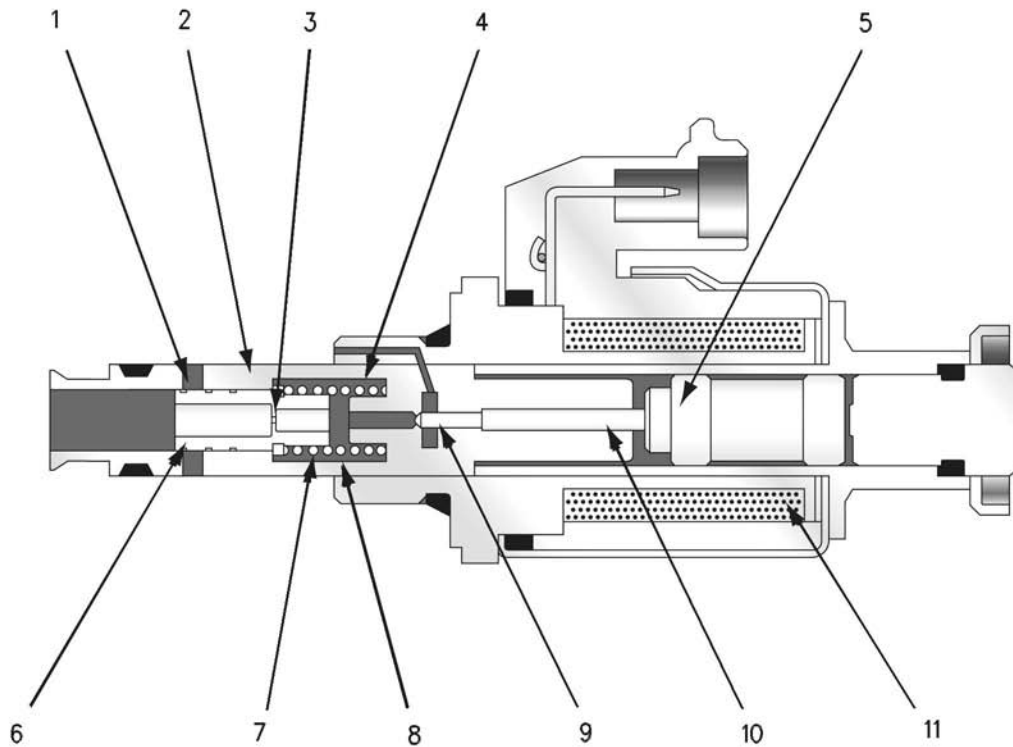

Illustration 11

g00295335

Injection actuation pressure control valve

- | | | |
|---------------------|--------------------------|---------------|
| (1) Drain port | (5) Armature | (9) Poppet |
| (2) Valve body | (6) Valve spool | (10) Push pin |
| (3) Control orifice | (7) Spool spring | (11) Solenoid |
| (4) Spool chamber | (8) Reduced pressure oil | |

The IAP Control Valve is an electrically controlled pilot operated pressure control valve. The Injection Actuation Pressure Control Valve is used in order to maintain selected actuation system pressure. The selected actuation system pressure is maintained regardless of engine speed, pump flow, and variable oil demand of the unit injectors. The IAP Control Valve consists of six basic components:

- Armature (5)
- Valve spool (6)
- Spool spring (7)
- Poppet (9)

- Push pin (10)
- Solenoid (11)

The IAP Control Valve operates by using a variable electrical current from the ECM in order to create a magnetic field in the solenoid (11). This magnetic field acts on armature (5) and the magnetic field generates a mechanical force. This mechanical force pushes armature (5) to the left. The mechanical force travels through push pin (10) to poppet (9).

The magnetic force that is holding poppet (9) closed is opposed by reduced hydraulic pressure inside the spool chamber. The reduced hydraulic pressure inside the spool chamber is trying to open poppet (9). This reduced hydraulic pressure increases until the reduced hydraulic pressure overcomes the mechanical force of solenoid (11). When the reduced hydraulic pressure overcomes the mechanical force of solenoid (11), poppet (9) opens. The open poppet allows a flow path to drain for some of the reduced pressure oil (8). Discharging part of reduced pressure oil (8) to drain lowers the hydraulic pressure. When the hydraulic pressure of reduced pressure oil (8) decreases below the magnetic force on poppet (9), the poppet closes again.

Valve Operation for ENGINE OFF

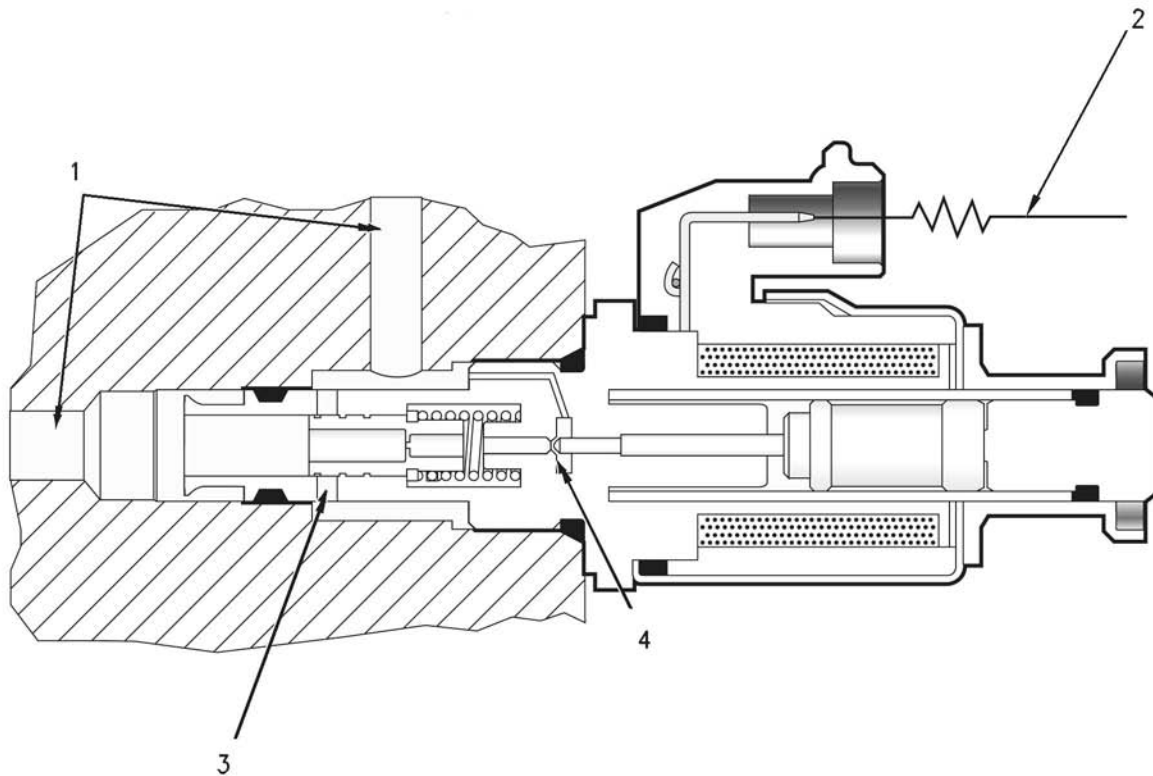

Illustration 12

g00295336

Operation of the injection actuation pressure control valve (engine off)

- | | |
|---------------------------------|----------------------------|
| (1) Pump outlet pressure (none) | (3) Closed drain port |
| (2) Current from ECM (none) | (4) Poppet (open position) |

When the engine is off, there is no pump outlet pressure (1) from the pump and there is no current to the solenoid from the ECM (2). The spool spring pushes the spool valve completely to the left. When the spool spring pushes the spool valve completely to the left, drain port (3) is completely blocked.

Valve Operation for ENGINE CRANKING

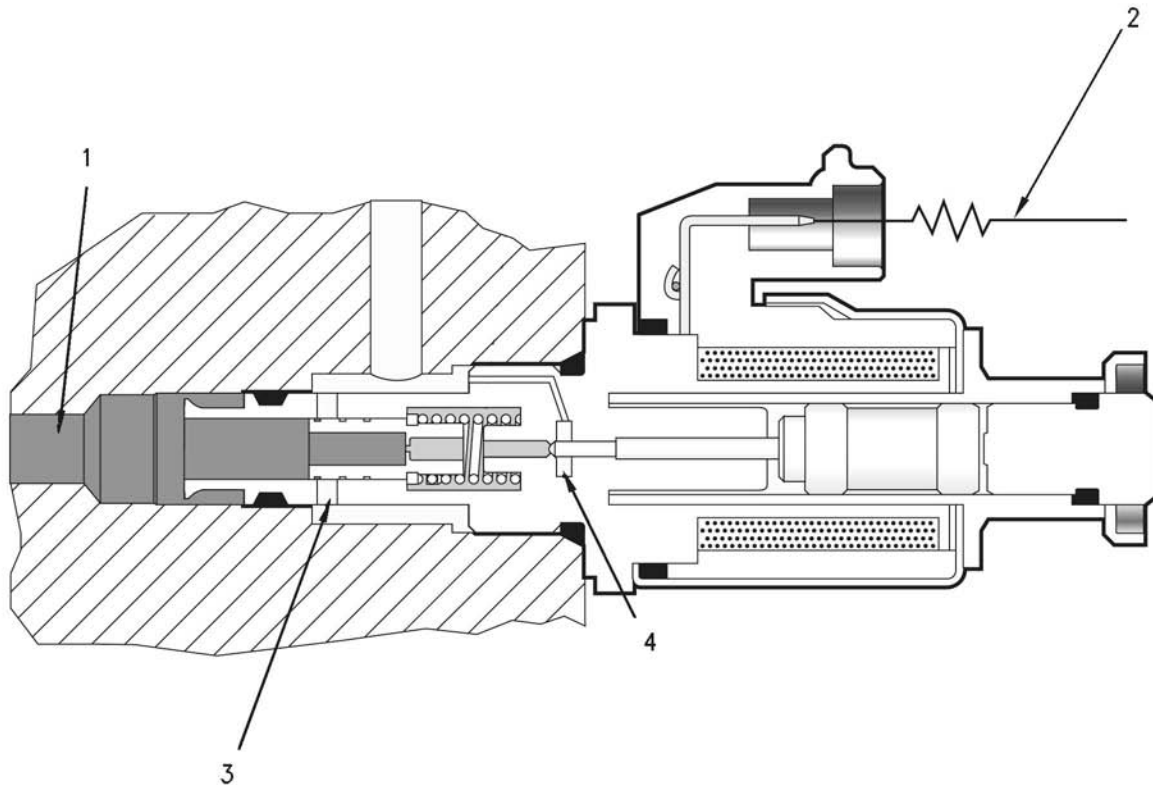

Illustration 13

g00295337

Operation of the injection actuation pressure control valve (engine cranking)

- | | |
|--------------------------|-----------------------------------|
| (1) Pump outlet pressure | (3) Drain port (blocked position) |
| (2) Current from the ECM | (4) Poppet (closed position) |

During engine start-up, approximately 6 MPa (870 psi) of injection actuation pressure is required in order to activate the unit injector. This low injection actuation pressure generates a low fuel injection pressure of about 35 MPa (5000 psi). This low fuel injection pressure aids cold starting.

In order to start the engine quickly, the injection actuation pressure must rise quickly. Because the unit injector hydraulic pump is being turned at engine cranking speed, pump flow is very low. The ECM sends a strong current (2) to the IAP Control Valve in order to keep the spool closed. With the spool in the closed position, all of the flow to drain port (3) is blocked. The flow to drain port (3) remains blocked until the actual actuation pressure of 6 MPa (870 psi) is reached. The unit injectors are not fired until the 6 MPa (870 psi) actual actuation pressure is reached.

Note: If the engine is already warm, the pressure that is required to start the engine may be higher than 6 MPa (870 psi). The values for the desired actuation pressures are stored in the performance maps of the ECM. The values for desired actuation pressures vary with engine temperature.

Once the unit injectors begin to operate, the ECM controls the current to the IAP Control Valve. The ECM and the IAP Control Valve maintain the actual actuation pressure at 6 MPa (870 psi) until the engine starts. The ECM monitors the actual actuation pressure through the IAP Sensor that is located in the high pressure oil manifold. The ECM establishes desired actuation pressure by monitoring several electrical input signals and the ECM sends a predetermined current to the IAP Control Valve. The ECM also compares the desired actuation pressure to the actual actuation pressure in the high pressure oil passage. The ECM adjusts the current levels to the IAP Control Valve in order to make the actual actuation pressure equal to the desired actuation pressure.

Oil Flow for ENGINE CRANKING

Pump outlet pressure (1) enters the end of the valve body and pump outlet pressure acts against the valve spool. The pump outlet pressure tries to push the valve spool to the right (open). A small amount of oil also flows through the center of the spool, through the spool control orifice and into the spool spring chamber. The current from the ECM (2) causes the solenoid to generate a magnetic field which pushes the armature to the left. The armature exerts a force on the push pin and the poppet which holds the poppet closed. The poppet is the only path to the drain for the oil in the spool spring chamber. Pump outlet pressure (1) flows through the spool control orifice and into the spool spring chamber. This flow of pump outlet pressure allows spring chamber pressure to build up. Because the spring chamber path to the drain is blocked by the poppet, the pressure in the spring chamber is equal to pump outlet pressure (1).

The combination of spool spring force and spring chamber pressure hold the spool to the left. When the spool is held to the left, the drain ports are closed. All pump flow is directed to the high pressure oil manifold until an actual actuation pressure of 6 MPa (870 psi) is reached.

Valve Operation for RUNNING ENGINE

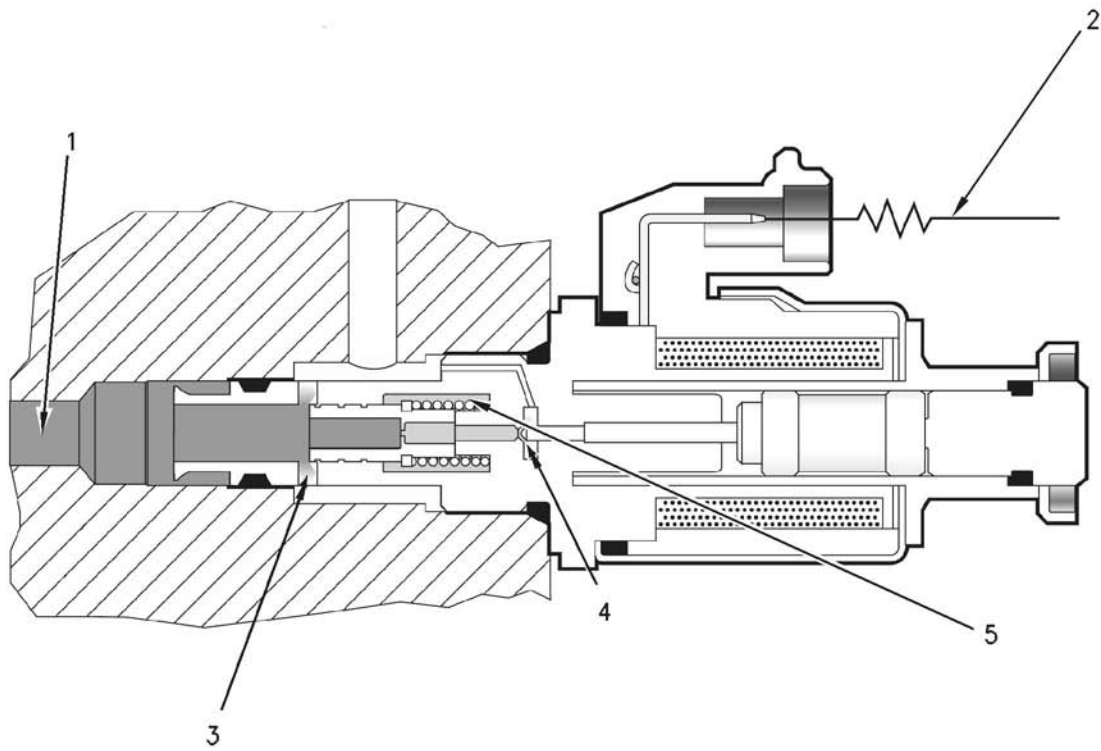

Illustration 14

g00295338

Operation of the injection actuation pressure control valve (running engine)

- | | | |
|--------------------------|-----------------------|--------------------------|
| (1) Pump outlet pressure | (3) Drain port (open) | (5) Reduced pressure oil |
| (2) Current from the ECM | (4) Poppet (open) | |

Once the engine starts, the ECM controls the current (2) to the IAP Control Valve in order to maintain the desired actuation pressure. The IAP Sensor monitors the actual actuation pressure in the high pressure oil passage in the cylinder head. The ECM compares the actual actuation pressure to the desired actuation pressure 67 times per second. When these pressures do not match, the ECM adjusts the current levels (2) to the IAP Control Valve in order to make the actual injection actuation pressure equal to the desired injection actuation pressure.

The amount of current that is sent to the solenoid regulates the amount of magnetic force that is trying to hold the poppet closed. The solenoid, the armature and the push pin simulate a variable spring that is electronically controlled. Increased current results in increased force. Decreased current results in decreased force.

The magnetic force that is applied to the poppet holds the poppet closed. When the poppet is closed, the pressure in the spool spring chamber increases. When the pressure in the spool spring chamber exceeds the magnetic force that is holding the poppet closed, the poppet (4) will move to the right. When the poppet (4) moves to the right, some of the pressure oil in the spool spring chamber escapes to the drain. This causes the pressure in the spring chamber to drop. When the pressure in the spring chamber drops, the poppet closes. When the poppet closes, the pressure again begins to increase and the cycle is repeated. This process controls the reduced pressure oil (5) in the spool spring cavity. The reduced pressure oil (5) in the spool spring cavity acts on the spool. The reduced pressure oil (5) in the spool spring cavity tries to move the spool to the left. When the spool is moved to the left, the drain port (3) is blocked.

The combined force of the mechanical spring and reduced pressure oil in the spool spring chamber try to move the spool to the left in order to block the drain port (3). When the drain port is blocked, pump outlet pressure (1) rises and the increased pump outlet pressure moves the spool to the right (open).

Because the mechanical spring has a fixed spring rate, the reduced pressure oil (5) in the spool must be adjusted in order to control pump outlet pressure (1). The reduced pressure oil (5) in the spool can be raised in order to control pump outlet pressure (1) or the reduced pressure oil (5) in the spool can be lowered in order to control pump outlet pressure (1). The reduced pressure oil (5) is controlled by the amount of electrical current from the ECM (2). Most of the time, the poppet and the spool operate in a partially open position. The poppet and the spool are completely open or completely closed only during the following conditions:

- Acceleration
- Deceleration
- Rapidly changing engine loads

Oil Flow for RUNNING ENGINE

When pump outlet pressure (1) enters the end of the valve body, a small amount of oil flows into the spool spring chamber through the control orifice in the spool. The pressure in the spool spring chamber is controlled by adjusting the force on the poppet (4). Adjusting the force on the poppet (4) allows the poppet to drain off some of the oil in the spool spring chamber. The force on the poppet is controlled by the strength of the magnetic field that is produced from the electrical current from the ECM (2). The spool responds to pressure changes in the spool spring chamber. The spool changes positions in order to balance the force on the spool. The spool tries to make the force on the right side of the spool equal to the force on the left side of the spool. The spool position dictates the amount of the surface area of the drain ports (3) that is open.

The open area of the drain port controls the amount of oil that is drained off from the pump outlet. The oil is drained off from the pump outlet in order to maintain the desired actuation pressure. The process of responding to pressure changes on either side of the spool occurs so rapidly that the spool is held in a partially open position and pump outlet pressure (1) is closely controlled. The IAP Control Valve allows infinitely variable control of pump outlet pressure (1) between 6 MPa (870 psi) and 27.5 MPa (4000 psi).

Components of the HEUI Injector

The HEUI injector serves four functions. The HEUI injector pressurizes supply fuel from 450 kPa (65 psi) to 162 MPa (23500 psi). The HEUI injector functions as an atomizer by pumping high pressure fuel through orifice holes in the unit injector tip. The HEUI injector delivers the correct amount of atomized fuel into the combustion chamber and the HEUI injector disperses the atomized fuel evenly throughout the combustion chamber.

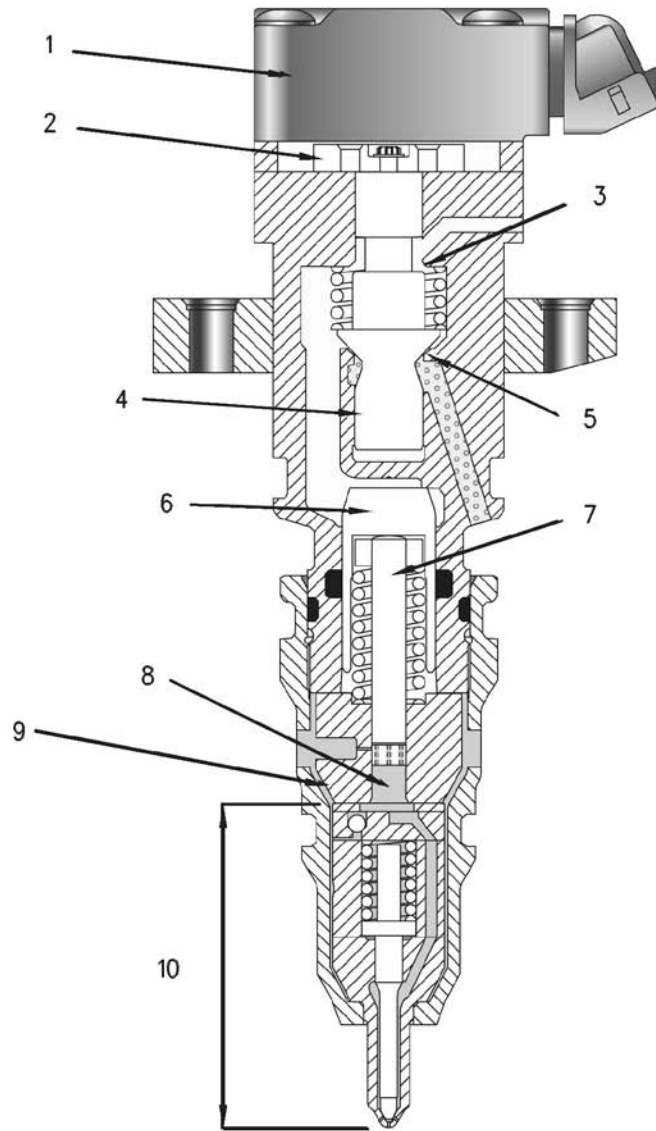

Illustration 15

g00295359

Component of the HEUI injector

- | | |
|-----------------------|------------------------|
| (1) Solenoid | (6) Intensifier piston |
| (2) Armature | (7) Plunger |
| (3) Upper poppet seat | (8) Plunger cavity |
| (4) Poppet valve | (9) Barrel |
| (5) Lower poppet seat | (10) Nozzle assembly |

The HEUI injector consists of five basic components:

- Solenoid (1)
- Poppet valve (4)
- Intensifier piston (6) and plunger (7)
- Barrel (9)
- Nozzle assembly (10)

Solenoid

The solenoid (1) is an electromagnet. When the solenoid is energized, the solenoid creates a very strong magnetic field. This magnetic field attracts the armature (2) which is connected to the poppet valve (4) by an armature screw. When the armature moves toward the solenoid, the armature lifts the poppet valve off the poppet valve's lower seat (5). Energizing the solenoid and lifting the poppet valve off the poppet valve's lower seat is the beginning of the fuel injection process.

Poppet Valve

The poppet valve (4) has two positions which are opened and closed. In the closed position, the poppet is held on the lower poppet seat (5) by a spring. The closed lower poppet seat prevents high pressure actuation oil from entering the unit injector. The open upper poppet seat (3) vents oil in the cavity that is above the intensifier piston (6) to the atmosphere. The oil is vented to the atmosphere through the upper portion of the unit injector. In the open position, the solenoid (1) is energized and the poppet valve is lifted off the poppet valve's lower seat. When the poppet valve is lifted off the poppet valve's lower seat, the lower poppet seat opens allowing high pressure actuation oil to enter the unit injector. When the high pressure actuation oil enters the unit injector, the high pressure actuation oil pushes on the top of intensifier piston (6). The upper poppet seat (3) of poppet valve (4) closes and upper poppet seat (3) of poppet valve (4) blocks the path to the drain. Blocking the path to the drain prevents the leakage of high pressure actuation oil from the unit injector.

Intensifier Piston

The surface area of intensifier piston (6) is six times larger than the surface area of plunger (7). This larger surface area provides a multiplication of force. This multiplication of force allows 27.5 MPa (4000 psi) of actuation oil to produce 162 MPa (23500 psi) of fuel injection pressure. When poppet valve (4) moves away from lower poppet seat (5), high pressure actuation oil enters the unit injector. When the high pressure actuation oil enters the unit injector, the high pressure actuation oil pushes on the top of intensifier piston (6). Pressure rises on top of the intensifier piston and the pressure pushes down on intensifier piston (6) and plunger (7). The downward movement of the plunger pressurizes the fuel in plunger cavity (8). The pressurized fuel in the plunger cavity causes nozzle assembly (10) to open. When the nozzle assembly opens, the fuel delivery into the combustion chamber begins. A large O-ring around the intensifier piston separates the oil above the intensifier piston from the fuel below the intensifier piston.

Barrel

The barrel (9) is the cylinder that holds plunger (7). The plunger moves inside the barrel. The plunger and barrel together act as a pump. Both the plunger and the barrel are precision components that have a working clearance of only 0.0025 mm (.00010 inch). These tight clearances are required in order to produce injection pressures over 162 MPa (23500 psi) without excessive leakage.

Note: A small amount of controlled leakage is required in order to lubricate the plunger which prevents wear.

The barrel (9) also contains the PRIME spill port.

The PRIME spill port is a small hole with a high precision tolerance. The PRIME spill port is machined through the side of barrel (9) into plunger (7). This port momentarily vents fuel injection pressure during the downward stroke of the plunger.

Nozzle Assembly

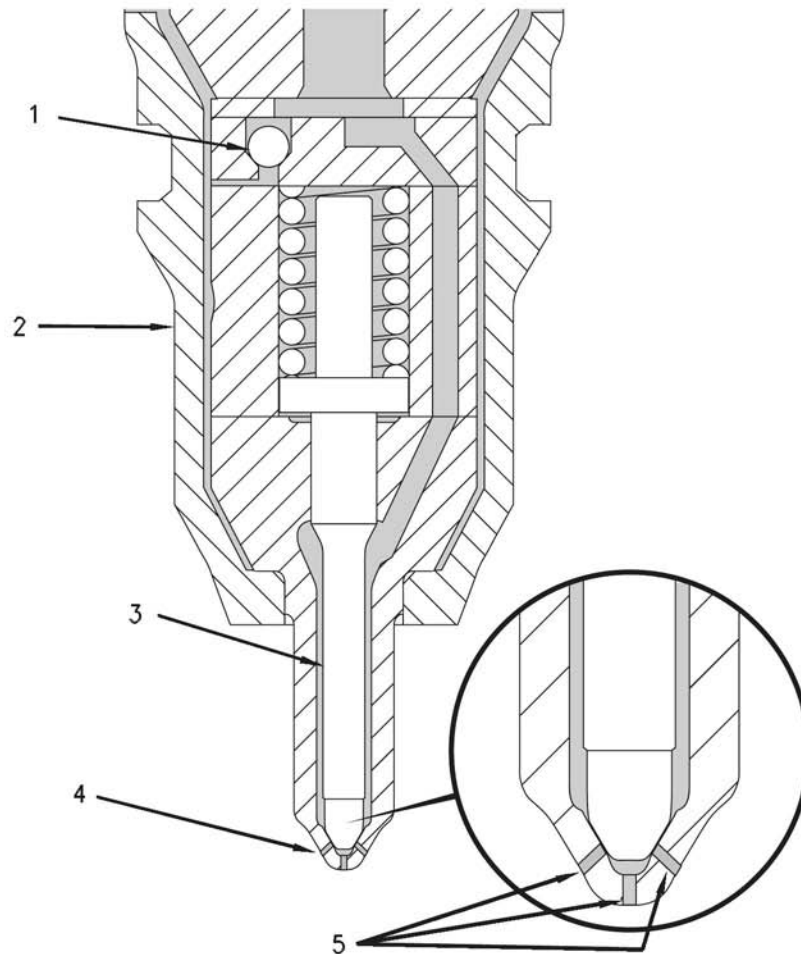

Illustration 16

g00295360

Nozzle assembly

(1) Inlet fill check ball
(2) Case

(3) Check
(4) Tip

(5) Tip orifice holes

The nozzle assembly is similar to all other unit injector's nozzle assemblies. Fuel that has been pressurized to the injection pressure flows from the plunger cavity through a passage in the nozzle to the nozzle tip (4). Fuel flow out of the tip is stopped by check (3), which covers the tip orifice holes (5) in the end of the tip (4). The force of a spring holds the check down in the closed position. This prevents the leakage of fuel out of tip (4) and this prevents the leakage of combustion gas into the unit injector when the cylinder fires.

When the injection pressure increases to approximately 28 MPa (4000 psi), the hydraulic force that is pushing on check (3) becomes greater than the spring force that is holding the check down. When the spring force is overcome by the hydraulic force, the check moves away from tip (4). When the check moves away from the tip, the check is in the open position. The amount of pressure that is required to open the check is called the Valve Opening Pressure (VOP). The fuel flows out of tip orifice holes (5) in the end of the tip and the fuel flows into the combustion chamber. The check remains open and fuel continues to flow out of the tip until fuel injection pressure drops below 28 MPa (4000 psi). When the pressure drops, the check closes and fuel injection is stopped. The amount of pressure that allows the check to close is called the Valve Closing Pressure (VCP).

Note: Valve Opening Pressures (VOP) and Valve Closing Pressures (VCP) vary among applications and horsepower ratings in order to meet exhaust emission standards. The above values were used as illustrations only.

The inlet fill check ball (1) unseats during upward travel of the plunger in order to allow the plunger cavity to refill. The inlet fill check ball seats during the downward stroke of the plunger and the inlet fill check ball seals during the downward stroke of the plunger. The inlet fill check ball seals during the downward stroke of the plunger in order to prevent fuel injection pressure leakage into the fuel supply.

Operation of the HEUI Fuel Injector

There are five stages of injection with the HEUI injector:

- Pre-injection
- Pilot injection
- Delay
- Main injection
- End of injection

Pre-Injection

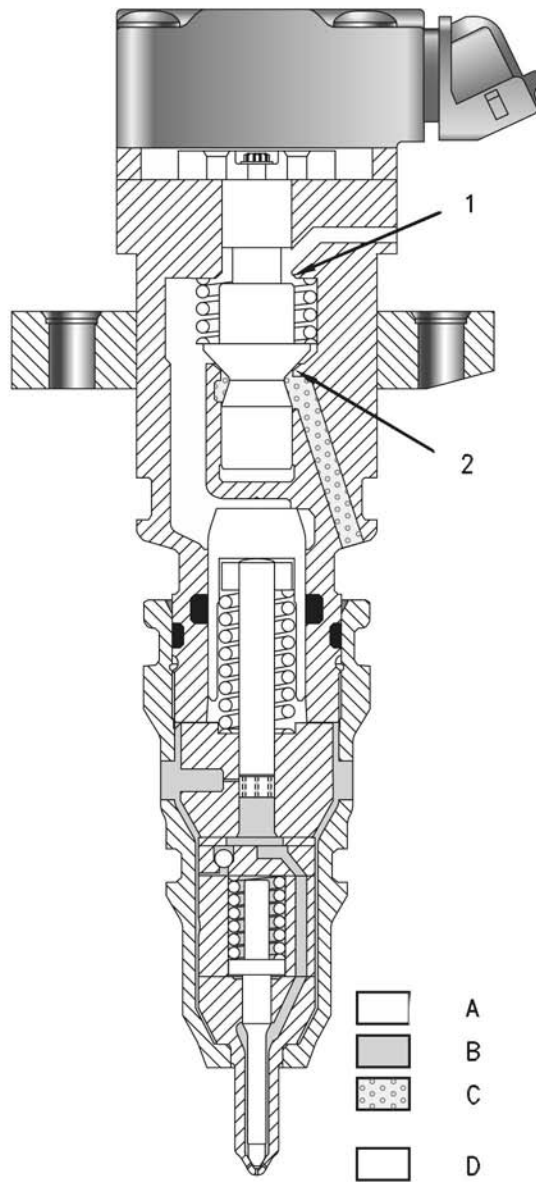

Illustration 17

g00295361

HEUI injector (Pre-injection)

(1) Upper poppet seat (open position)
(2) Closed lower poppet seat

(A) Drain (atmosphere)
(B) Fuel supply pressure

(C) Actuation oil pressure
(D) Moving parts

All of the internal components have been returned to the spring loaded position during the pre-injection. The solenoid is not energized and the lower poppet seat (2) is closed. When the lower poppet seat is closed, the lower poppet seat blocks high pressure actuation oil from entering the unit injector. The plunger and the intensifier piston are at the top of the bore and the plunger cavity is full of fuel. Fuel pressure in the plunger cavity is equal to the fuel supply pressure. The fuel supply pressure is approximately 450 kPa (65 psi).

Pilot Injection

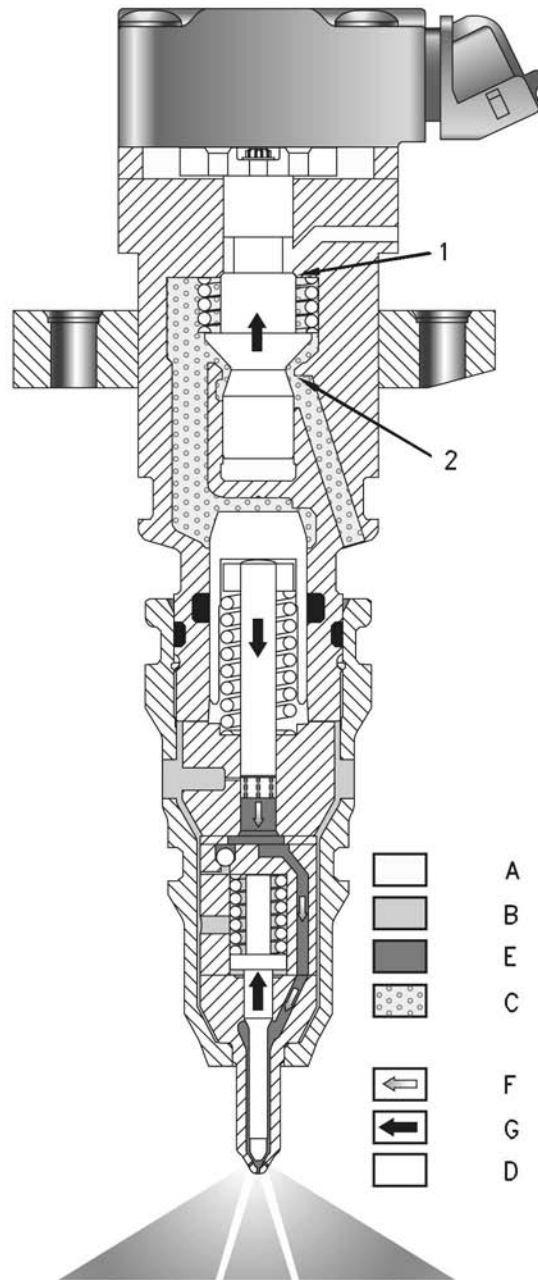

Illustration 18

HEUI injector (Pilot Injection)

- (1) Upper poppet seat (closed position)
- (2) Lower poppet seat (open position)
- (A) Drain (atmosphere)

- (B) Fuel supply pressure
- (C) Actuation oil pressure
- (D) Moving parts

- (E) Injection pressure
- (F) Fuel flow
- (G) Mechanical movement

When the ECM activates the unit injector, the ECM sends a current to the unit injector solenoid. The current causes the solenoid to produce a strong magnetic field which creates a pull on the armature. The armature is mechanically connected to the poppet valve by a screw. The magnetic pull of the solenoid overcomes the spring tension that is holding the poppet valve closed. When the poppet valve opens, the poppet moves away from the lower poppet seat.

When the poppet valve opens, the upper poppet seat (1) blocks the path to the drain and the lower poppet seat (2) opens the poppet chamber to incoming high pressure actuation oil. High pressure oil flows around the poppet. The high pressure oil flows through a passage onto the top of the intensifier piston. High pressure oil acts on the top of the intensifier piston. The piston and the plunger are pushed down by the high pressure oil. The downward movement of the plunger pressurizes the fuel in the plunger cavity and nozzle assembly. When the pressure reaches Valve Opening Pressure (VOP) of approximately 28 MPa (4000 psi), the check lifts up from the seat in the tip. When the check lifts up from the seat in the tip, injection begins.

Pre-Injection Metering (PRIME)

The 3126B and 3126E diesel engine's fuel system has a unique feature that is called PRIME. Pre-Injection Metering (PRIME) is a feature that offers a significant benefit in lower emissions. Also, PRIME offers a significant benefit in reducing combustion noise. While other fuel systems deliver a single large quantity of fuel into the combustion chamber, PRIME injectors break the delivery into two separate quantities. The first quantity is a small pilot injection which is followed by a short delay. Then, the injector delivers a large main injection. The pilot injection is not intended to produce power. The pilot injection is intended to establish a flame front. The pilot injection will help the larger main injection burn more completely and the pilot injection will help the larger main injection burn in a controlled manner.

Under certain engine operating conditions, when fuel is delivered in one large injection, the fuel tends to explode rather than burn in a controlled manner. This results in engine knock. When fuel explodes rather than burns in a controlled manner, engine knock and excess NOx emissions result.

The PRIME feature produces a small pilot injection that is followed by a brief delay. The brief delay gives the pilot injection the time that is required to start burning. The main injection follows the pilot injection and the main injection is delivered into the flame front that was established by the pilot injection. The main injection is immediately ignited. The main injection burns smoothly and the main injection burns completely. This complete combustion significantly reduces particulate emission (soot) and NOx. This complete combustion also reduces combustion noise from the engine up to 50 percent. This reduction of combustion noise from the engine results in noticeably quieter engine operation. The actual operation of PRIME is described in the following information.

Injection Delay

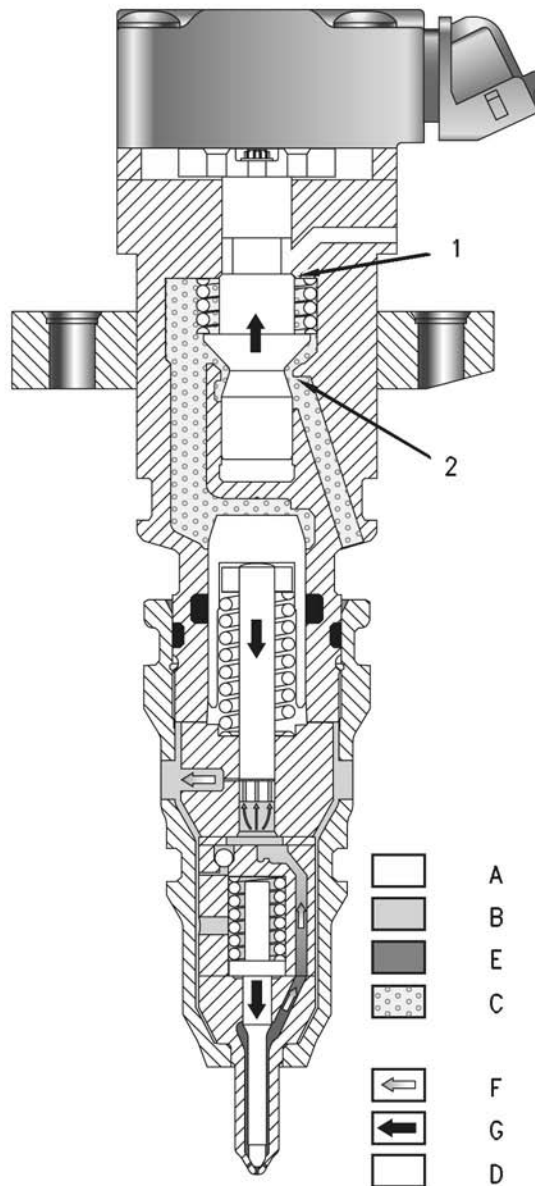

Illustration 19
HEUI injector delay

g00295363

(1) Upper poppet seat (closed position)
(2) Lower poppet seat (open position)
(A) Drain (atmosphere)

(B) Fuel supply pressure
(C) Actuation oil pressure
(D) Moving parts

(E) Injection pressure
(F) Fuel flow
(G) Mechanical movement

The plunger continues moving downward and the plunger continues to inject fuel into the combustion chamber. Until the PRIME groove in the plunger lines up with the PRIME spill port in the barrel, the plunger continues to inject fuel into the combustion chamber. When the groove in the plunger aligns with the spill port, high pressure fuel under the plunger can flow upward. The high pressure fuel flows through three holes in the bottom of the plunger. Then, the high pressure fuel flows out of the groove of the plunger and the spill port and the fuel flows back into the fuel supply passage. This loss of high pressure fuel causes injection pressure to drop below Valve Closing Pressure (VCP). The spring force overcomes the hydraulic force of the reduced injection pressure. When the spring force overcomes the hydraulic force of the reduced injection pressure, the check closes and fuel injection stops. This is the end of the pilot injection and the start of the short injection delay period.

Main Injection

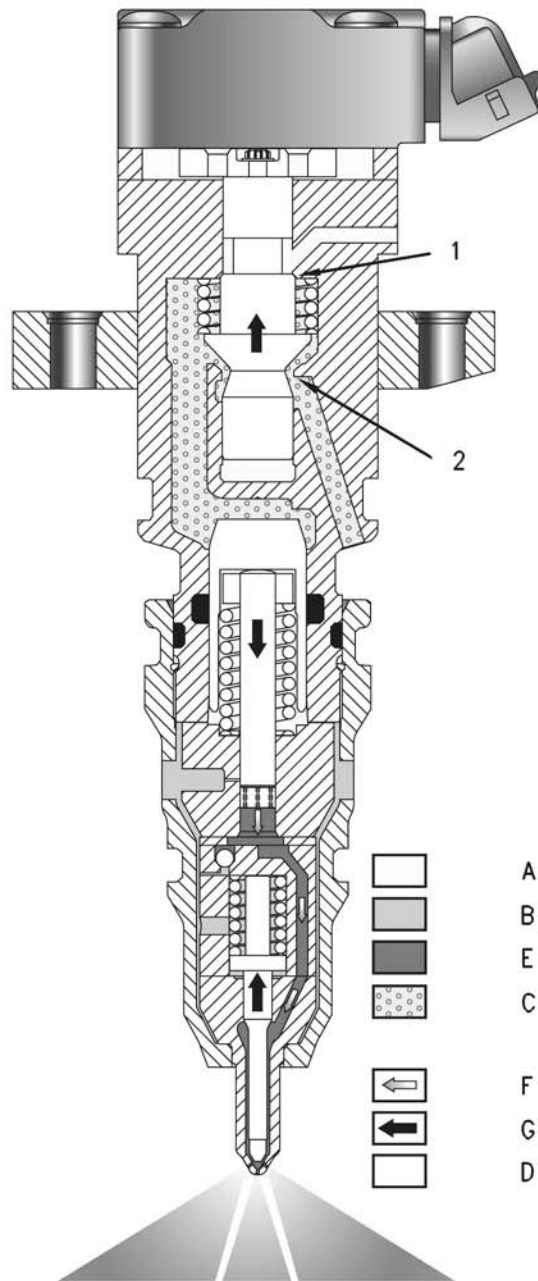

Illustration 20

HEUI injector (Main Injection)

- (1) Upper poppet seat (closed position)
- (2) Lower poppet seat (open position)
- (A) Drain (atmosphere)

- (B) Fuel supply pressure
- (C) Actuation oil pressure
- (D) Moving parts

- (E) Injection pressure
- (F) Fuel flow
- (G) Mechanical movement

While the solenoid is energized, the poppet valve remains open. While the poppet valve is open, high pressure oil continues to flow. The flow of the high pressure oil pushes downward on the intensifier piston and the plunger. The injection pressure fluctuates between 34 MPa (5000 psi) and 162 MPa (23500 psi). The injection pressure depends on the engine's requirements. Injection continues until either the solenoid is de-energized or the intensifier piston hits the bottom of the bore. When the solenoid is de-energized, the poppet spring is allowed to close the poppet valve. When the poppet valve closes, high pressure oil is shut off.

End of Injection

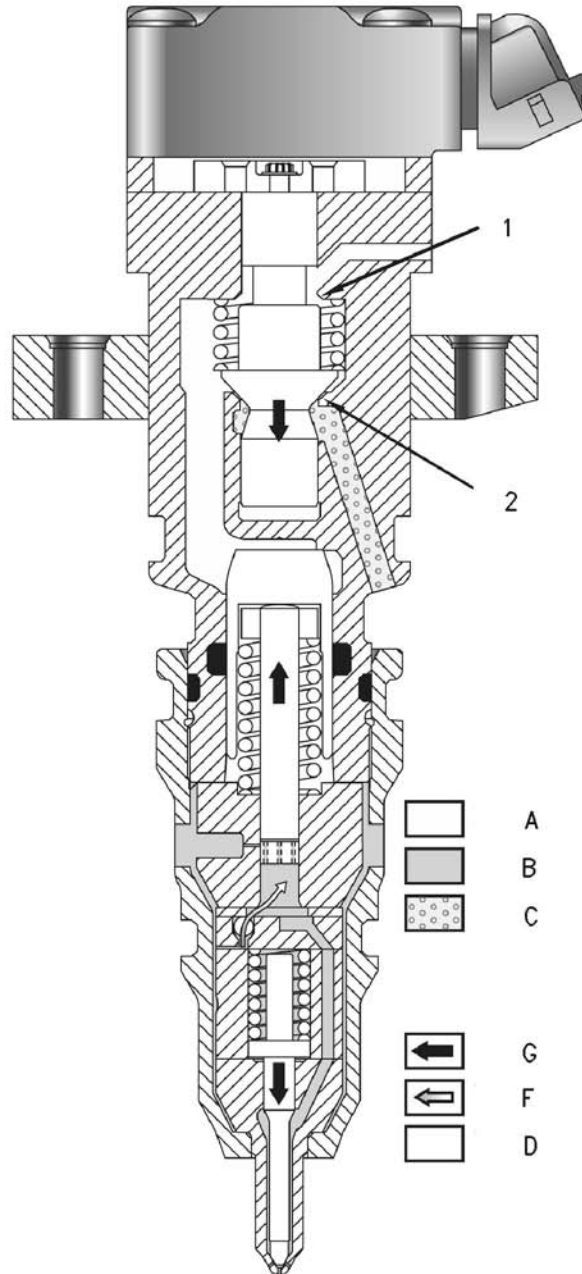

Illustration 21

g00295365

HEUI injector (End of Injection)

- (1) Upper poppet seat (open position)
- (2) Lower poppet seat (closed position)
- (A) Drain (atmosphere)
- (B) Fuel supply pressure

- (C) Actuation oil pressure
- (D) Moving parts
- (F) Fuel flow
- (G) Mechanical movement

The end of the injection cycle begins when the ECM stops the current to the unit injector solenoid. The magnetic field of the solenoid breaks down and the magnetic field is unable to overcome the spring force of the poppet. The poppet returns to the lower poppet seat which closes the poppet valve. When the poppet valve closes, high pressure oil is stopped from entering the unit injector. As the lower poppet seat closes, the upper poppet seat opens to the drain. When the upper poppet seat opens to the drain, the actuation pressure of the oil drops off.

Fuel injection pressure under the plunger exerts an upward force on the plunger and the intensifier piston. As the pressure of the actuation oil above the intensifier piston drops off, the downward force on the intensifier piston drops off. The upward force of the fuel injection pressure under the plunger suddenly becomes greater than the downward force on the intensifier piston. The downward motion of the intensifier piston and the plunger stops.

The exhaust oil on top of the intensifier piston can flow to the drain through the open upper poppet seat. Then, the oil flows through a vent hole to the rocker arm compartment under the valve cover.

When the downward travel of the plunger stops, fuel flow also stops. While the check is still open, the remaining fuel pressure pushes a small amount of fuel out of the orifice holes. This causes a large pressure drop which lowers injection pressure below Valve Closing Pressure (VCP). Spring tension on the check now reseats the check into the tip and injection stops.

When the check closes, injection stops. When injection stops, the fill cycle starts. The area above the intensifier piston cavity is open to atmospheric pressure through the upper poppet seat. Pressure drops very rapidly in the cavity above the intensifier piston to near zero. The return spring of the plunger pushes up on the plunger and the intensifier piston. As the plunger and the intensifier piston move upward, oil is forced around the upper poppet seat. After the oil is forced around the upper poppet seat, the oil is forced out of a vent hole.

As the plunger rises, pressure in the plunger cavity also drops to near zero. The fuel supply pressure is 450 kPa (65 psi). Fuel supply pressure unseats the plunger fill check in order to fill the plunger cavity with fuel. When the intensifier piston is pushed to the top of the bore, the fill cycle ends. When the fill cycle ends, the plunger cavity is full and the inlet fill check ball is reseated. Pressure above the intensifier piston and the poppet chamber is zero. The fuel injection cycle is complete and the unit injector is ready to begin again. The unit injector is now back in the pre-injection cycle.

Fuel Heater And Water Separator (If Equipped)

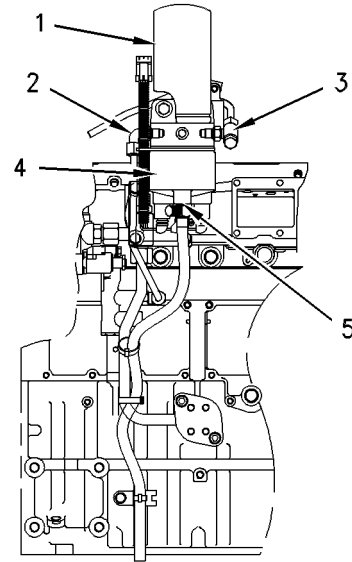

Illustration 22

g00291751

- (1) Fuel filter
- (2) Fuel inlet
- (3) Fuel outlet
- (4) Fuel heater and water separator
- (5) Drain valve

Some engines may have a combination of a fuel heater and a water separator. The fuel heater is controlled by a thermostat that is located in the base of the unit. The thermostat is preset. When the fuel temperature is below 4°C (40°F), the thermostat will turn on the heater. When the fuel temperature is 15°C (60°F), the thermostat will turn off the heater.

Water that has been separated from the fuel can be drained from the unit by lifting up on drain valve (5).

i01538883

Air Inlet and Exhaust System

SMCS Code: 1050

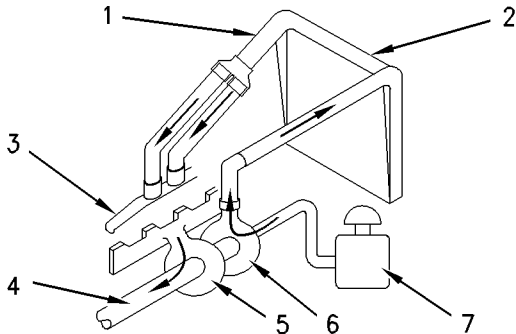

Illustration 23 g00787037

Airflow Schematic

(1) Air line. (2) Aftercooler core. (3) Air inlet elbow. (4) Exhaust outlet from turbocharger. (5) Turbine side of turbocharger. (6) Compressor side of turbocharger. (7) Air cleaner.

The components of the air inlet and exhaust system control the quality of the air that is available for combustion. These components also control the amount of the air that is available for combustion. The components of the air inlet and exhaust system are listed below:

- Air cleaner
- Turbocharger
- Aftercooler
- Cylinder head
- Valves and valve system components
- Piston and cylinder
- Exhaust manifold

Inlet air is pulled through the air cleaner. The inlet air is then compressed and heated by the compressor wheel of turbocharger (6) to about 150°C (300°F). The inlet air is then pushed through air-to-air aftercooler core (2) and the inlet air is moved to air inlet elbow (3). The temperature of the inlet air at air inlet elbow (3) is about 43°C (110°F). Cooling of the inlet air increases the combustion efficiency. Increased combustion efficiency helps to lower fuel consumption. Also, increased combustion efficiency helps to increase horsepower output.

Aftercooler core (2) is a separate cooler core. Aftercooler core (2) is installed in front of the core (standard) of the engine radiator on the machine. Air that is ambient temperature is moved across the aftercooler core by the engine fan. This cools the turbocharged inlet air.

From aftercooler core (2), the air is forced into the cylinder head in order to fill the inlet ports. Air flow from the inlet port into the cylinder is controlled by the inlet valves.

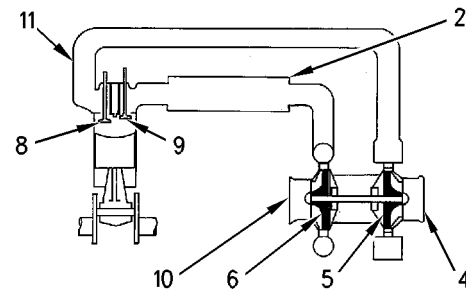

Illustration 24 g00805952

Air Inlet And Exhaust System

(2) Aftercooler core. (4) Exhaust outlet. (5) Turbine side of turbocharger. (6) Compressor side of turbocharger. (8) Exhaust valve. (9) Inlet valve. (10) Air inlet. (11) Exhaust manifold.

There are two inlet valves and one exhaust valve for each cylinder. Inlet valves open when the piston moves down on the inlet stroke. When the inlet valves open, cooled compressed air from the inlet port is pulled into the cylinder. The inlet valves close and the piston begins to move up on the compression stroke. The air in the cylinder is compressed. When the piston is near the top of the compression stroke, fuel is injected into the cylinder. The fuel mixes with the air and combustion starts. During the power stroke, the combustion force pushes the piston downward. After the power stroke is complete, the piston moves upward. This upward movement is the exhaust stroke. During the exhaust stroke, the exhaust valve opens, and the exhaust gases are pushed through the exhaust port into the exhaust manifold. After the piston completes the exhaust stroke, the exhaust valve closes and the cycle starts again. The complete cycle consists of four stages:

- Inlet stroke
- Compression stroke
- Power stroke
- Exhaust stroke

Exhaust gases from exhaust manifold (11) enter the turbine side of turbocharger (5) in order to turn the turbine wheel. The turbine wheel is connected to a shaft which drives the compressor wheel. Exhaust gases from the turbocharger pass through the exhaust outlet pipe, the muffler and the exhaust stack.

Turbocharger

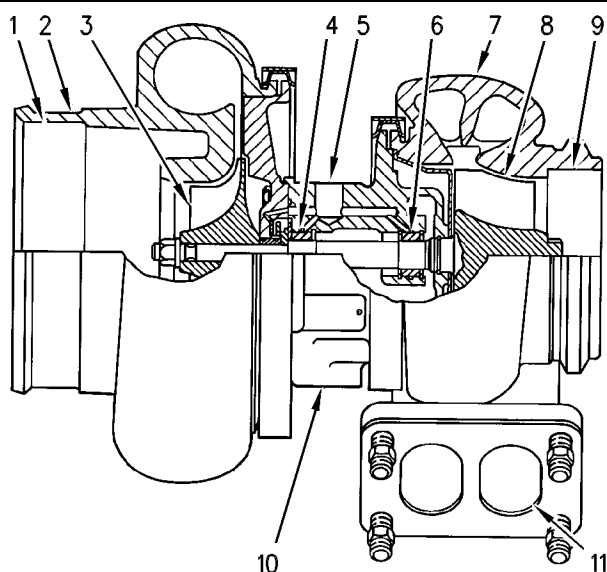

Illustration 25

g00294193

Turbocharger

(1) Air inlet. (2) Compressor housing. (3) Compressor wheel. (4) Bearing. (5) Oil Inlet port. (6) Bearing. (7) Turbine housing. (8) Turbine wheel. (9) Exhaust outlet. (10) Oil outlet port. (11) Exhaust inlet.

The turbocharger is installed on the center section of the exhaust manifold. All the exhaust gases from the engine go through the turbocharger. The compressor side of the turbocharger is connected to the aftercooler by a pipe.

The exhaust gases go into turbine housing (7) through exhaust inlet (11). The exhaust gases then push the blades of turbine wheel (8). The turbine wheel is connected by a shaft to compressor wheel (3).

Clean air from the air cleaners is pulled through compressor housing air inlet (1) by the rotation of compressor wheel (3). The action of the compressor wheel blades causes a compression of the inlet air. This compression gives the engine more power by allowing the engine to burn more air and more fuel during combustion.

When the load on the engine increases, more fuel is injected into the cylinders. The combustion of this additional fuel produces more exhaust gases. The additional exhaust gases cause the turbine and the compressor wheels of the turbocharger to turn faster. As the compressor wheel turns faster, more air is forced into the cylinders. The increased flow of air gives the engine more power by allowing the engine to burn the additional fuel with greater efficiency.

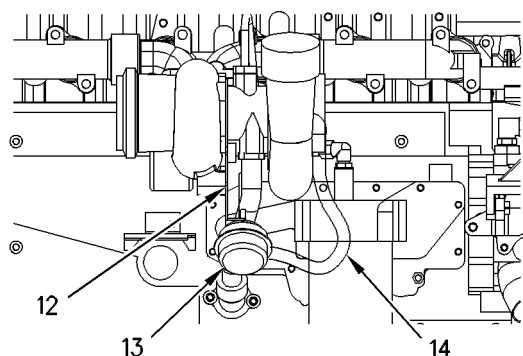

Illustration 26

g00294194

Turbocharger With Wastegate

(12) Actuating lever. (13) Canister. (14) Line (boost pressure).

When the engine is operating under conditions of low boost, a spring pushes on a diaphragm in canister (13). This action moves actuating lever (12) in order to close the valve of the wastegate. Closing the valve of the wastegate allows the turbocharger to operate at maximum performance.

As the boost pressure through line (14) increases against the diaphragm in canister (13), the valve of the wastegate is opened. When the valve of the wastegate is opened, the rpm of the turbocharger is limited by bypassing a portion of the exhaust gases. The exhaust gases are routed through the wastegate which bypasses the turbine wheel of the turbocharger.

Note: The turbocharger with a wastegate is preset at the factory and no adjustment can be made.

Bearings (4) and (6) for the turbocharger use engine oil under pressure for lubrication. The oil comes in through oil inlet port (5). The oil then goes through passages in the center section in order to lubricate the bearings. Oil from the turbocharger goes out through oil outlet port (10) in the bottom of the center section. The oil then goes back to the engine lubrication system.

Valve System Components

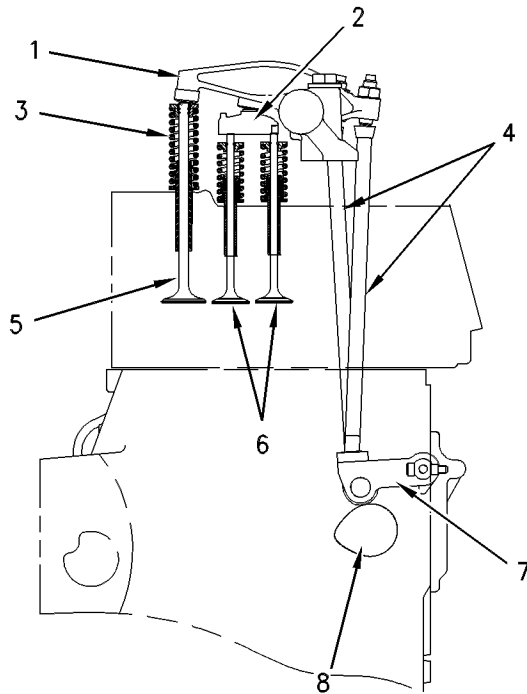

Illustration 27

g00294195

Valve System Components

(1) Rocker arms. (2) Bridge. (3) Spring. (4) Pushrods. (5) Exhaust valve. (6) Inlet valves. (7) Lifter. (8) Camshaft lobe.

The valve system components control the flow of inlet air into the cylinders during engine operation. The valve system components also control the flow of exhaust gases out of the cylinders during engine operation.

The crankshaft gear drives the camshaft gear through an idler gear. The camshaft must be timed to the crankshaft in order to get the correct relation between the piston movement and the valve movement.

The camshaft has two camshaft lobes for each cylinder. The lobes operate the inlet and exhaust valves. As the camshaft turns, lobes on the camshaft cause lifters (7) to move pushrods (4) up and down. Upward movement of the pushrods against rocker arms (1) results in downward movement (opening) of valves (5) and (6).

Each cylinder has two inlet valves and one exhaust valve. Valve springs (3) close the valves when the lifters move down.

Air Inlet Heater

The engines are equipped with an electric heater that is located behind the air inlet elbow. The electric heater has two functions:

- Aid in starting
- Aid in white smoke cleanup during start-up

Under the proper conditions, the ECM turns on the electric heater. The following conditions are evaluated prior to activating the electric heater:

- Jacket water coolant temperature
- Inlet manifold air temperature
- Ignition switch position
- Duration of time

The system is capable of delivering heat for 30 seconds prior to start-up and during cranking of the engine. After the engine has started, the system is capable of delivering heat constantly for 7 minutes, or the system can cycle the heat for 13 minutes. During the heating cycle, the heat is on for ten seconds and the heat is off for ten seconds.

If the air inlet heater malfunctions, the engine will still start and the engine will still run. There may be a concern regarding the amount of white smoke that is present. Also, there may be a concern regarding the need for an alternative starting aid.

System Components

The system of the air inlet heater consists of the following basic components:

- Relay of the air inlet heater
- Heater element
- Coolant temperature sensor
- Inlet air temperature sensor
- ECM
- Indicator lamp

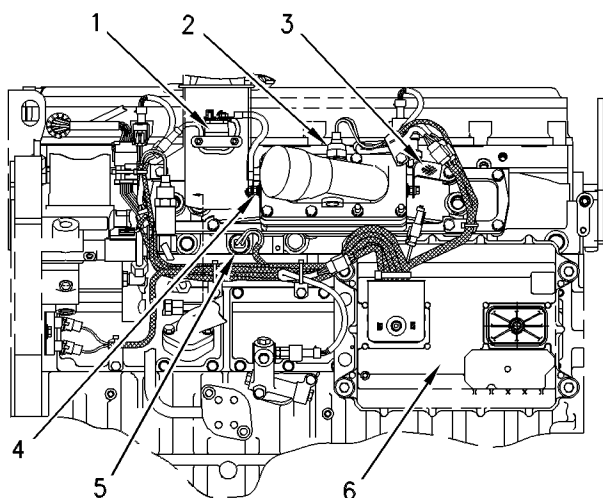

Illustration 28

g00294196

Location Of Components

(1) Relay of the air inlet heater. (2) Inlet air temperature sensor. (3) Ground strap (heater to engine). (4) Air inlet heater. (5) Coolant temperature sensor. (6) ECM.

The relay for the air inlet heater (1) is located on the mounting bracket for the fuel filter. The relay turns the 12 V heater ON and OFF in response to signals from the ECM (6).

The air inlet heater (4) is a component of the air inlet cover. The heater element has a ground strap (3) that must be connected to the engine.

There are three conditions that would cause the air inlet heater to be activated:

- Powerup and Mode of Preheat

Regardless of temperature, the heater and the lamp of the heater should come on for two seconds when the ECM is first powered (lamp check). When the sum of the coolant temperature plus the inlet manifold air temperature is less than 25°C (109°F), the ECM will turn on the heater and the lamp for 30 seconds. This is a cycle of preheat.

The ECM will then turn off the heater and the lamp. When the operator attempts to start the engine prior to the completion of preheat, the ECM proceeds into the mode of cranking for heater control.

- Mode of cranking

During engine cranking, when the sum of the coolant temperature plus the inlet manifold air temperature is less than 25°C (109°F), the ECM will turn on the heater. The heater will remain on during engine cranking. If the engine fails to start, the ECM reverts to preheat. Reverting to preheat will activate the heater for another 30 seconds.

- Running of the engine

After the engine has started, the same combination of inlet manifold air temperature and coolant temperature will determine the state of the heater. The cycle has two strategies.

The two strategies are continuous and intermittent. During the continuous strategy, the heater will remain on for a maximum of 7 minutes after starting. If the same conditions exist, the ECM will activate the intermittent strategy. During the intermittent strategy, the heater is cycled for a maximum of 13 minutes. During this cycle, the heater is turned on for 10 seconds and the heater is turned off for 10 seconds. After the 13 minute time limit, the heater is shut off.

When one of the temperature sensors fails, the system will operate in the following manner:

- Coolant temperature sensor

When the coolant temperature sensor has an open circuit or a short circuit, the coolant temperature sensor has failed. During this condition, the heater will be activated when the inlet manifold air temperature is less than 10°C (50°F).

- Inlet air temperature sensor

When the inlet air temperature sensor has an open circuit or a short circuit, the inlet air temperature sensor has failed. During this condition, the heater will be activated when the coolant temperature is less than 40°C (104°F).

Under the proper condition, the heater will be reactivated. When the sum of the coolant temperature and the inlet manifold air temperature has dropped below 25°C (109°F), the heater will be reactivated. This condition could exist after a warm engine has cooled and the operator attempts to start the engine.

When the sum of the coolant temperature and the inlet manifold air temperature does not attain 35°C (127°F), the heater will be activated. The heater can be activated no longer than 20 minutes (maximum). The ECM will turn off the heater after the 20 minute time limit.

For additional information on the air inlet heater, refer to Troubleshooting, "Air Inlet Heater Circuit - Test".

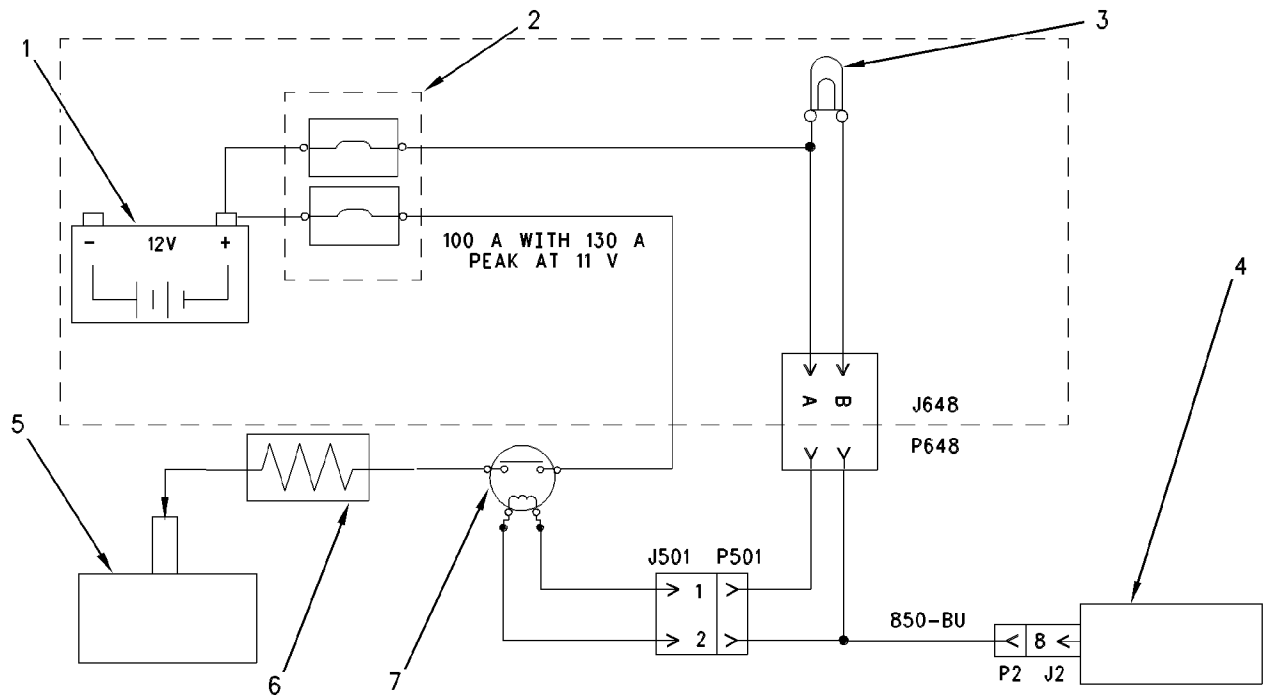
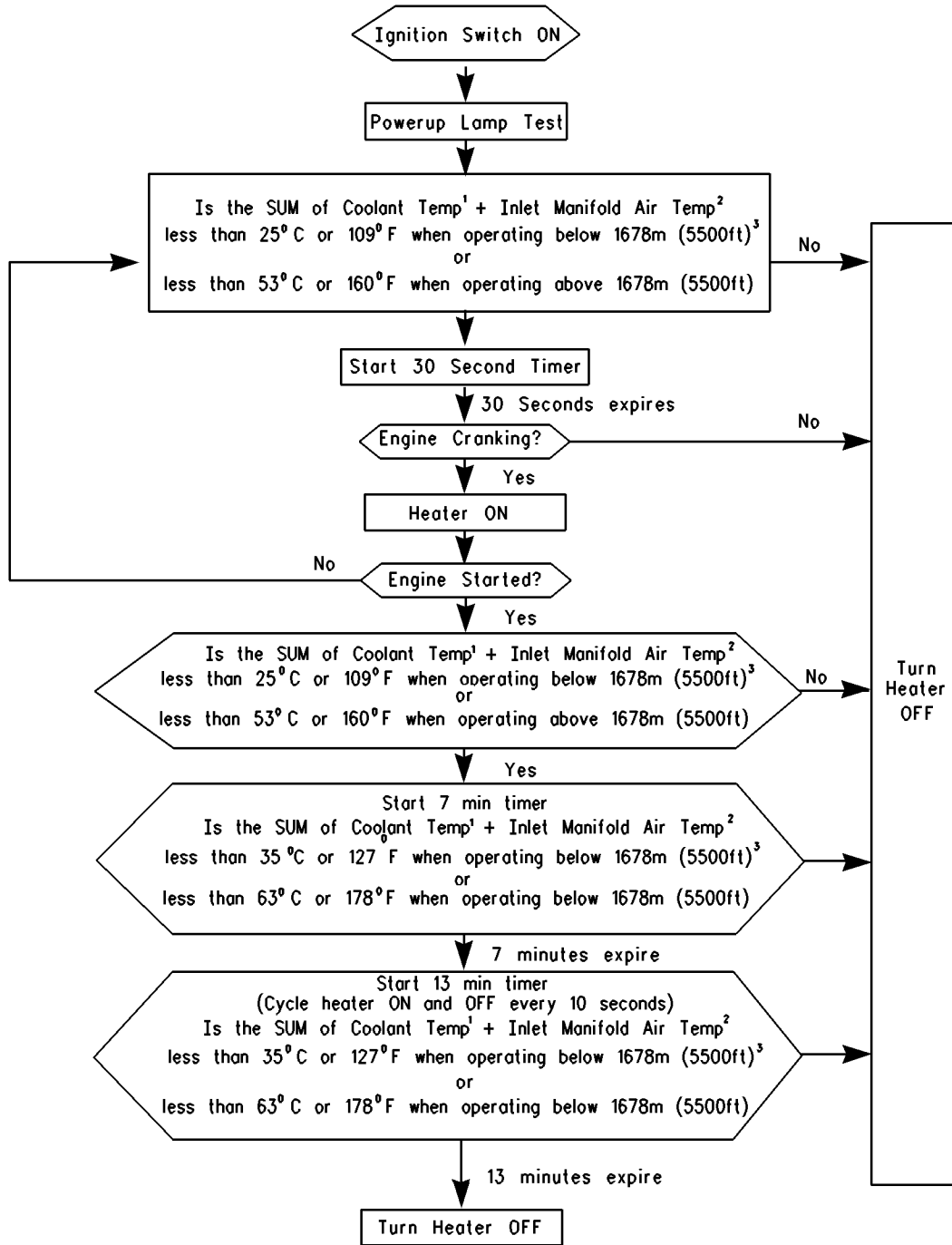

Illustration 29

g00786279

Schematic Of Air Inlet Heater (Typical Example)

(1) Battery. (2) Fuse panel. (3) Lamp of air inlet heater. (4) ECM. (5) Engine ground. (6) Air inlet heater. (7) Relay of air inlet heater.



¹ If a coolant temperature sensor open circuit or short circuit diagnostic code is active, the heater will come ON if Inlet Manifold air temperature <10°C (50°F)

² If an Inlet Manifold air temperature sensor open circuit or short circuit diagnostic code is active, the heater will come ON if coolant temperature <40°C (140°F)

³ With APR99 and Newer Personality Modules, the Boost Pressure reading is used to determine Atmospheric Pressure. This indicates if the engine is operating above 1678m (5500ft). If so, the temperature calculations used to determine Inlet Air Heater operation are adjusted to compensate for the extreme altitude operation.

i01486056

Lubrication System

SMCS Code: 1300

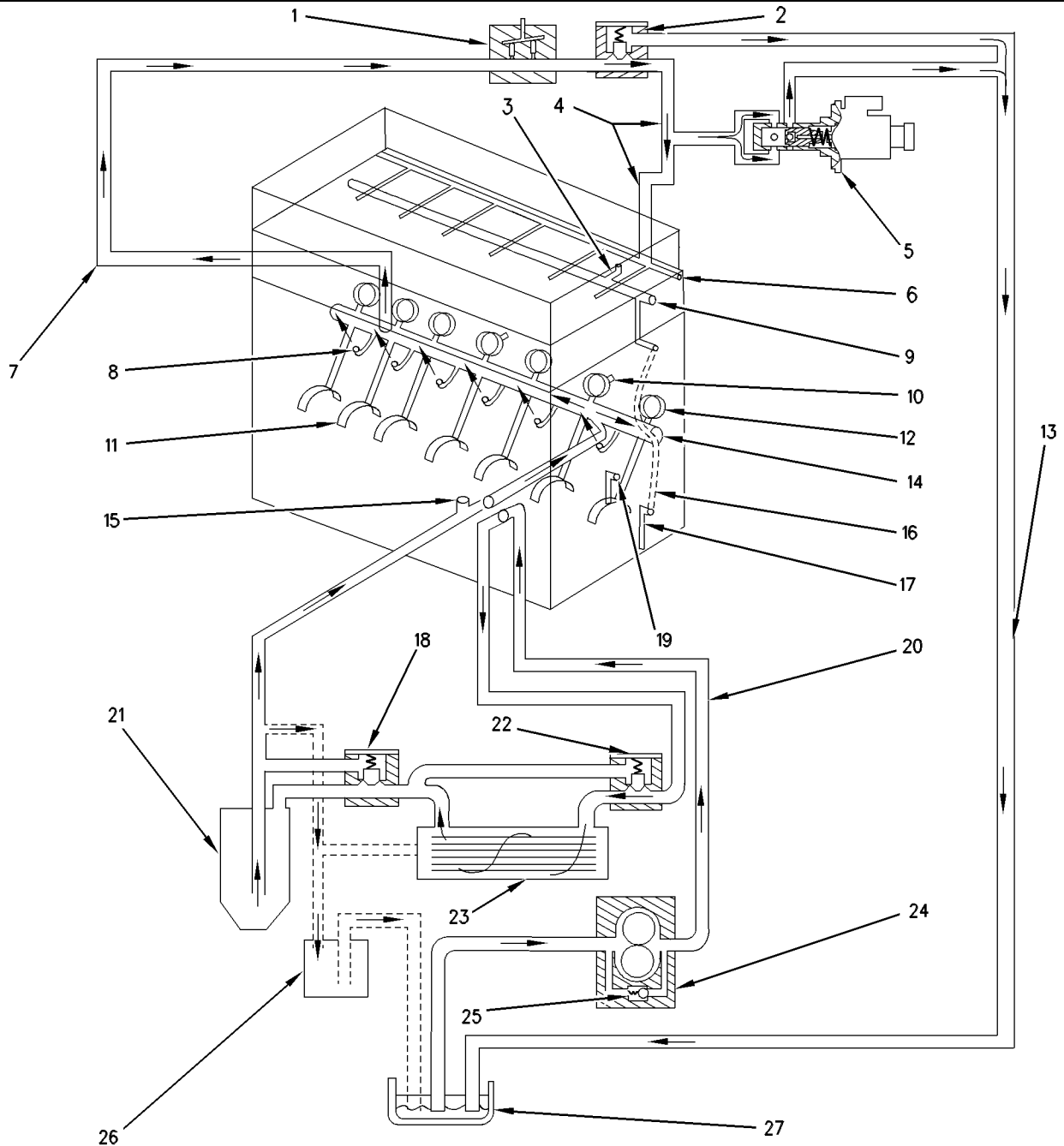

Illustration 31

g00292659

Lubrication System Schematic

(1) Hydraulic pump. (2) High pressure oil line. (3) Passage to the rocker arms. (4) High pressure oil line. (5) Injection actuation pressure control valve. (6) High pressure oil manifold. (7) Oil supply line for hydraulic pump. (8) Piston cooling jets. (9) Cylinder head gallery. (10) Passage to pushrod lifters. (11) Main bearings. (12) Camshaft bearing. (13) Passage to engine oil pan. (14) Main oil gallery. (15) Turbocharger oil supply line. (16) Passage to front housing. (17) Passage to oil pump idler gear bearing. (18) Oil filter bypass valve. (19) Passage to camshaft idler gear bearing. (20) Passage. (21) Engine oil filter. (22) Oil cooler bypass valve. (23) Engine oil cooler. (24) Engine oil pump. (25) Oil pump bypass valve. (26) Auxiliary engine oil filter (if equipped). (27) Engine oil pan.

Engine oil pump (24) is mounted to the bottom of the cylinder block inside the engine oil pan (27). The engine oil pump (24) pulls oil from engine oil pan (27). The engine oil pump pushes the oil through the passage to the engine oil cooler (23). Oil then flows through engine oil filter (21). The filtered oil then enters the turbocharger oil supply line (15) and main oil gallery (14).

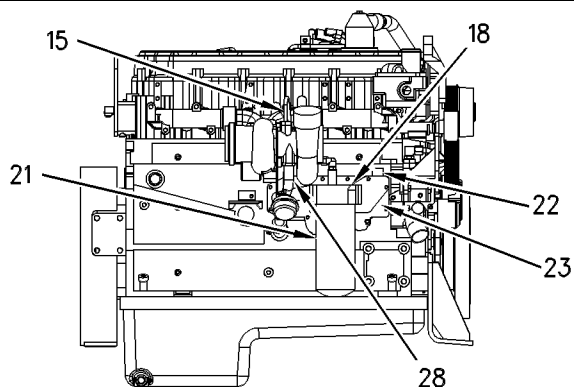

Illustration 32

g00292660

Right Side View Of Engine

(15) Turbocharger oil supply line. (18) Oil filter bypass valve. (21) Engine oil filter. (22) Oil cooler bypass valve. (23) Oil cooler. (28) Turbocharger oil return tube.

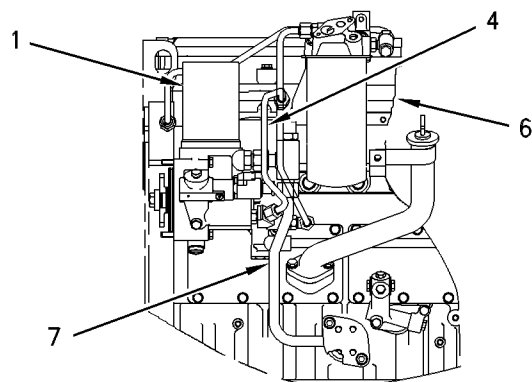

Illustration 33

g00292662

Left Side View Of Engine

(1) Hydraulic pump. (4) Oil supply line (high pressure). (6) Oil manifold (high pressure). (7) Oil supply line (hydraulic pump).

The main oil gallery (14) distributes oil to main bearings (11), piston cooling jets (8), and camshaft bearing (12). Oil from main oil gallery (14) exits the front of the block. The oil then enters a groove that is cast in front housing (16).

Oil enters the crankshaft through holes in the bearing surfaces (journals) for the main bearing (11). Passages connect the bearing surface (journal) for the main bearing (11) with the bearing surface (journal) for the connecting rod.

The passage in front housing (16) sends the oil flow in two directions. At the upper end of the passage, oil is directed back into the block and up to cylinder head gallery (9) through passage (3) to the rocker arm mechanism. A passage (17) sends oil to the oil pump idler gear bearing.

Oil from the front main bearing enters a passage (19) to the camshaft idler gear bearing. Oil passages in the crankshaft send oil from all the main bearings (11) through the connecting rods to the connecting rod bearings.

The passages send oil from the camshaft bearing (12) to an oil passage in the side covers. The oil then enters a hole in the shafts to pushrod lifters (10). The oil lubricates the bearings of the lifter.

Note: Engines that are equipped with an auxiliary oil filter (26) will receive oil at a port. The filtered oil will be returned to engine oil pan (27).

The hydraulic pump (1) is a gear-driven axial piston pump. The hydraulic pump raises the engine oil pressure from the typical operating oil pressure to the actuation pressure that is required by the unit injectors. The injection actuation pressure control valve (5) electronically controls the output pressure of the hydraulic pump (1).

The oil circuit consists of a low pressure circuit and a high pressure circuit. The low pressure circuit typically operates at a pressure of 240 kPa (35 psi) to 480 kPa (70 psi). The low pressure circuit provides engine oil that has been filtered to the hydraulic pump (1). Also, the low pressure circuit provides engine oil that has been filtered to the lubricating system of the engine. Oil is drawn from the engine oil pan (27). Oil is supplied through the engine oil cooler (23) and engine oil filter (21) to both the engine and the hydraulic pump (1).

The high pressure oil system provides actuation oil to the unit injector. The high pressure circuit operates in a pressure range typically between 4 MPa (581 psi) and 23 MPa (3350 psi). This high pressure oil flows through a line into the cylinder head. The cylinder head stores the oil at actuation pressure. The oil is ready to actuate the unit injector. Oil is discharged from the unit injector under the valve cover so that no return lines are required.

After the lubrication oil's work is done, the lubrication oil returns to the engine oil pan.

The oil pump bypass valve (25) limits the pressure of the oil that is coming from the engine oil pump (24). The engine oil pump (24) can pump more than enough oil into the system. When there is more than enough oil, the oil pressure increases. When the oil pressure increases, the oil pump bypass valve (25) will open. This allows the oil that is not needed to go back to the suction side of the engine oil pump (24).

The bypass valves (22) and (18) will open when the engine is cold (starting conditions). Opening the bypass valves achieves immediate lubrication of all components. Immediate lubrication is critical when cold oil with high viscosity causes a restriction to the oil flow through engine oil cooler (23) and engine oil filter (21). The engine oil pump (24) sends the cold oil through the bypass valves around the engine oil cooler (23) and engine oil filter (21) to the turbocharger oil supply line (15) and the main oil gallery (14) in the cylinder block.

When the oil gets warm, the pressure difference in the bypass valves decreases and the bypass valves close. After the bypass valves close, there is a normal flow of oil through the engine oil cooler and the engine oil filter.

The bypass valves will also open when there is a restriction in the engine oil cooler (23) or engine oil filter (21). This design allows the engine to be lubricated even though engine oil cooler (23) or engine oil filter (21) are restricted.

The engine oil cooler bypass valve is also activated by pressure. If the oil pressure differential across the engine oil cooler reaches 125 ± 30 kPa (18 ± 4.5 psi), the valve will open. Opening the valve allows the oil flow to bypass the engine oil cooler (23).

The main oil flow now reaches the main engine oil filter (21). When the oil pressure differential across the oil filter bypass valve (18) reaches 125 ± 30 kPa (18 ± 4.5 psi), the valve opens in order to allow the oil flow to go around the oil filter (21). The oil flow continues in order to lubricate the engine components. When the oil is cold, an oil pressure difference in the bypass valve also causes the valve to open. This bypass valve then provides immediate lubrication to all the engine components when cold oil with high viscosity causes a restriction to the oil flow through the engine oil filter (21). The bypass valve will also open when there is a restriction in the engine oil filter (21). This design allows the engine to be lubricated even though engine oil filter (21) is restricted.

Note: Refer to Specifications, "Engine Oil Filter Base".

Filtered oil flows through the main oil gallery (14) in the cylinder block. Oil is supplied from the main oil gallery (14) to the following components:

- Piston cooling jets (8)
- Valve mechanism
- Camshaft bearing (12)

- Crankshaft main bearings
- Turbocharger cartridge

An oil cooling chamber is formed by the lip that is forged at the top of the skirt of the piston and the cavity that is behind the ring grooves in the crown. Oil flow for the piston cooling jet enters the cooling chamber through a drilled passage in the skirt. Oil flow from the piston cooling jet returns to the engine oil pan (27) through the clearance gap between the crown and the skirt. Four holes that are drilled from the piston oil ring groove to the interior of the piston drain excess oil from the oil ring.

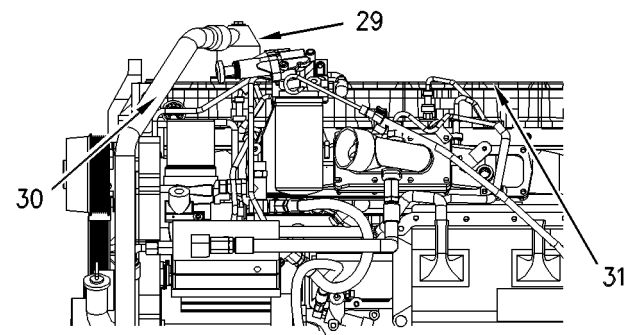

Illustration 34
Front Left Side View Of Engine
(29) Breather. (30) Hose. (31) Valve cover.

g00292663

Breather (29) allows engine blowby to escape from the crankcase. The engine blowby is discharged through hose (30) into the atmosphere. This prevents pressure from building up that could cause seals or gaskets to leak.

i00665400

Cooling System

SMCS Code: 1350

This engine has a pressure type cooling system that is equipped with a shunt line.

A pressure type cooling system offers two advantages:

- The cooling system can operate safely at a temperature that is higher than the normal boiling point of water.
- The cooling system prevents cavitation in the water pump.

Cavitation is the sudden formation of low pressure bubbles in liquids by mechanical forces. The formation of air or steam pockets is more difficult within a pressure type cooling system.

The shunt line prevents cavitation by the water pump. The shunt line provides a constant flow of coolant to the water pump.

Note: In air to air aftercooled systems, a coolant mixture with a minimum of 30 percent ethylene glycol base antifreeze must be used for efficient water pump performance. This mixture keeps the cavitation temperature range of the coolant high enough for efficient performance.

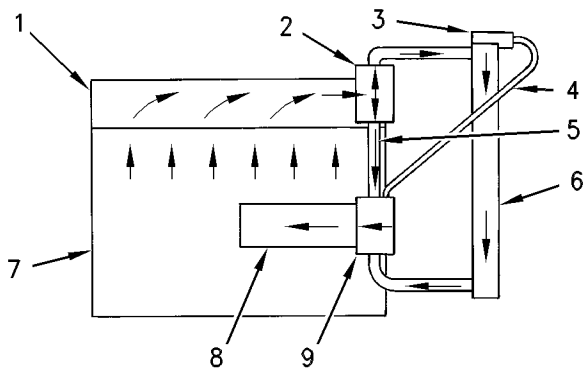

Illustration 35

g00293080

Cooling System Schematic

(1) Cylinder head. (2) Water temperature regulator housing. (3) Expansion tank. (4) Shunt line (expansion tank to water pump). (5) Bypass hose. (6) Radiator. (7) Cylinder block. (8) Oil cooler. (9) Water pump.

Water pump (9) is located on the right side of the cylinder block. The water pump is belt driven from the crankshaft pulley. Coolant can enter the water pump in three places:

- the inlet at the bottom of the water pump
- the bypass hose (5) into the top of the water pump
- the shunt line (4) into the top of the water pump

Coolant from the bottom of the radiator is pulled into the bottom inlet of the pump by impeller rotation. The coolant exits the back of the pump directly into the oil cooler cavity of the block.

All of the coolant passes through the core of the oil cooler and the coolant enters the internal water manifold of the cylinder block. The manifold disperses the coolant to water jackets around the cylinder walls.

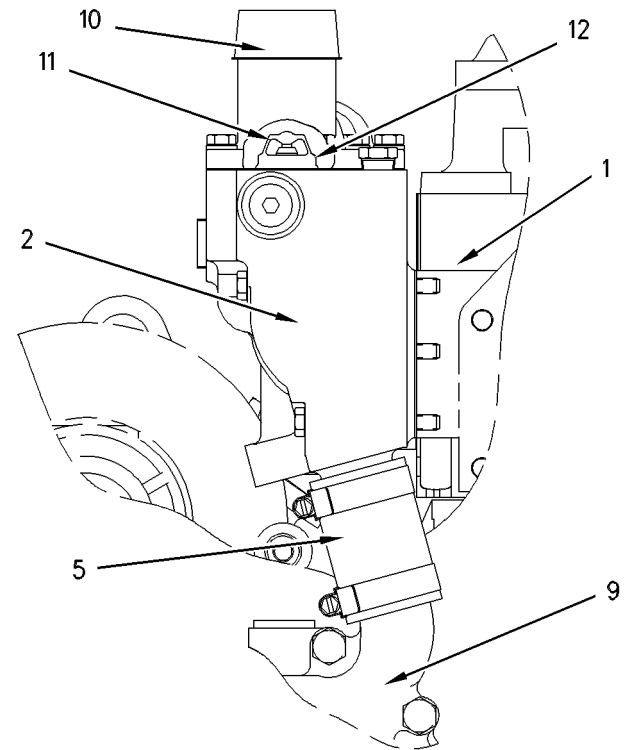

Illustration 36

g00293081

Water Lines Group

(1) Cylinder head. (2) Water temperature regulator housing. (5) Bypass hose. (9) Water pump. (10) Outlet to radiator. (11) Water temperature regulator. (12) Air vent valve in thermostat.

From the cylinder block, the coolant flows into passages in the cylinder head. The passages send the flow around the unit injector sleeves and the inlet and the exhaust passages. The coolant now enters water temperature regulator housing (2) at the front right side of the cylinder head.

Water temperature regulator (11) controls the direction of flow. When the coolant temperature is below the normal operating temperature, the water temperature regulator is closed. The coolant is directed through bypass hose (5) and into the top inlet of the water pump. When the coolant temperature reaches the normal operating temperature, water temperature regulator (11) opens. When the water temperature regulator is open, the bypass is closed. Most of the coolant goes through outlet (10) to the radiator for cooling. The remainder flows through bypass hose (5) and into the water pump.

Note: Some coolant systems may contain two water temperature regulators.

The shunt line (4) extends from the top of the water pump to an expansion tank. The shunt line must be routed properly in order to avoid trapping any air. By providing a constant flow of coolant to the water pump, the shunt line keeps the water pump from cavitation.

Note: Water temperature regulator (11) is an important part of the cooling system. The water temperature regulator divides coolant flow between the radiator and the bypass in order to maintain the normal operating temperature. If the water temperature regulator is not installed in the system, there is no mechanical control, and most of the coolant will travel the path of least resistance through the bypass. This will cause the engine to overheat in hot weather and the engine will not reach normal operating temperature in cold weather.

Note: Air vent valve (12) will allow the air to escape past the water temperature regulator from the cooling system while the radiator is being filled. During normal operation, the air vent valve will be closed in order to prevent coolant flow past the water temperature regulator.

Coolant For Air Compressor (If Equipped)

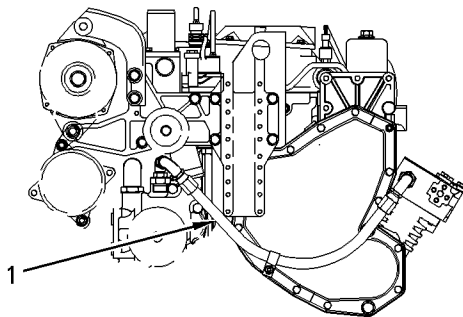

VIEW A-A

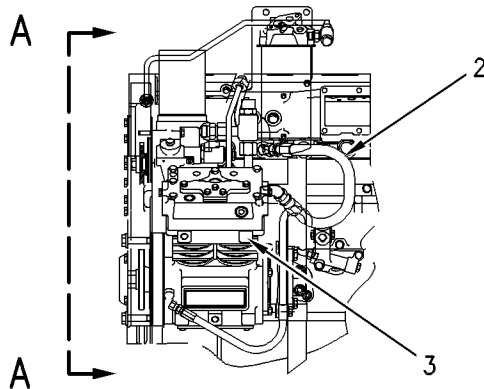

Illustration 37

g00293082

Coolant Lines For Air Compressor

(1) Coolant supply line. (2) Coolant return line. (3) Air compressor.

If the engine is equipped with an air compressor, coolant is supplied from the water temperature regulator housing to air compressor (3) through coolant supply line (1). The coolant is circulated through the air compressor and the coolant is returned to the cooling system through coolant return line (2) into the cylinder head.

Coolant Conditioner (If Equipped)

Some conditions of operation can cause pitting. This pitting is caused by corrosion or by cavitation erosion. A corrosion inhibitor is a chemical that provides a reduction in pitting. The addition of a corrosion inhibitor can keep this type of damage to a minimum.

The coolant conditioner element is a spin-on element that is similar to the fuel filter and to the oil filter elements. The coolant conditioner element attaches to the coolant conditioner base that is mounted on the front of the engine. Coolant flows from the water pump to the coolant conditioner base and back to the cylinder block. Coolant constantly flows through the coolant conditioner element when the valves are in the OPEN position.

The element has a specific amount of inhibitor for acceptable cooling system protection. As the coolant flows through the element, the corrosion inhibitor goes into the solution. The corrosion inhibitor is a dry solution, so the inhibitor dissolves. The corrosion inhibitor then mixes to the correct concentration. Two basic types of elements are used for the cooling system. The two elements are the precharge elements and the maintenance elements. Each type of element has a specific use. The elements must be used correctly in order to get the necessary concentration for cooling system protection. The elements also contain a filter. The elements should remain in the system so that coolant will flow through after the conditioner material is dissolved.

The precharge element contains more than the normal amount of inhibitor. The precharge element is used when a system is first filled with new coolant. This element must add enough inhibitor in order to bring the complete cooling system up to the correct concentration.

The maintenance elements have a normal amount of inhibitor. The maintenance elements are installed at the first change interval. A sufficient amount of inhibitor is provided by the maintenance elements in order to maintain the corrosion protection at an acceptable level. After the first change interval, only maintenance elements are installed. In order to provide the cooling system with protection, maintenance elements are installed at specific intervals.

i01855280

Basic Engine

SMCS Code: 1200

Cylinder Block And Head

The cylinder block has seven main bearings. The main bearing caps are fastened to the cylinder block with two bolts for each cap.

Removal of the oil pan allows access to the crankshaft, the main bearing caps, the piston cooling jets, and the oil pump.

The camshaft is accessible through the covers on the left side of the cylinder block. These side covers support the pushrod lifters. The camshaft is supported by bearings that are pressed into the cylinder block. There are seven camshaft bearings.

The cylinder head is separated from the cylinder block by a nonasbestos fiber gasket with a steel backing. Coolant flows out of the cylinder block through gasket openings and into the cylinder head. This gasket also seals the oil supply and drain passages between the cylinder block and the cylinder head.

The air inlet ports are on the left side of the cylinder head, while the exhaust ports are located on the right side of the cylinder head. There are two inlet valves and one exhaust valve for each cylinder. Replaceable valve guides are pressed into the cylinder head. The hydraulically actuated electronically controlled unit injector is located between the three valves. Fuel is injected directly into the cylinders at very high pressure. A pushrod valve system controls the valves.

Piston, Rings And Connecting Rods

Two-Piece Pistons

The two-piece articulated piston consists of an alloy forged steel crown that is connected to an aluminum skirt by the piston pin. The two-piece articulated piston has three rings:

- Compression ring
- Intermediate ring
- Oil ring

All of the rings are located above the piston pin bore. The compression ring is a Keystone ring. Keystone rings have a tapered shape. The action of the ring in the piston groove that is tapered helps prevent seizure of the rings. Seizure of the rings is caused by deposits of carbon. The intermediate ring is rectangular with a sharp lower edge. The oil ring is a standard type of ring or a conventional type of ring. Oil returns to the crankcase through holes in the oil ring groove.

Oil from the piston cooling jets sprays the underside of the pistons. The spray lubricates the pistons and the spray cools the pistons. The spray also improves the piston's life and the spray also improves the ring's life.

The connecting rod has a taper on the pin bore end. This taper gives the connecting rod and the piston more strength. The additional strength is concentrated in the areas with the most load. Two bolts hold the connecting rod cap to the connecting rod. This design keeps the connecting rod width to a minimum, so that the connecting rod can be removed through the cylinder.

Crankshaft

The crankshaft changes the combustion forces in the cylinder into usable rotating torque which powers the equipment. A vibration damper is used at the front of the crankshaft to reduce torsional vibrations (twist on the crankshaft) that can cause damage to the engine.

The crankshaft drives a group of gears on the front of the engine. The gear group can drive any of the following devices:

- Oil pump
- Camshaft
- Hydraulic oil pump
- Gear-driven air compressor
- Power steering pump

In addition, belt pulleys on the front of the crankshaft may drive any of the following components:

- Radiator fan
- Water pump

- Alternator
- Refrigerant compressor

Hydrodynamic seals are used at both ends of the crankshaft to control oil leakage. The hydrodynamic grooves in the seal lip move lubrication oil back into the crankcase as the crankshaft turns. The front seal is located in the front housing. The rear seal is installed in the flywheel housing.

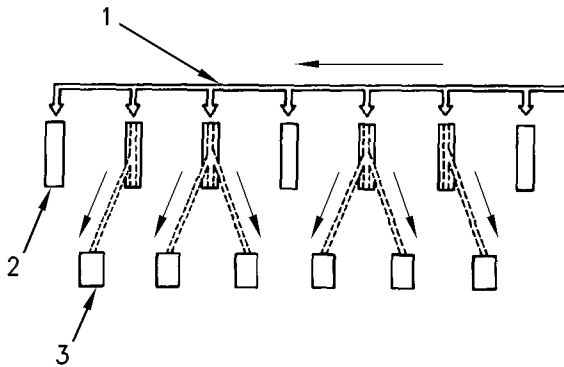

Illustration 38 g00293227

Schematic of oil passages in crankshaft

- (1) Oil gallery
- (2) Main bearings
- (3) Connecting rod bearings

Pressure oil is supplied to all main bearings through drilled holes in the webs of the cylinder block. The oil then flows through drilled holes in the crankshaft in order to provide oil to the connecting rod bearings. The crankshaft is held in place by seven main bearings. A thrust bearing next to the rear main bearing controls the end play of the crankshaft.

Vibration Damper

The force from combustion in the cylinders will cause the crankshaft to twist. This is called torsional vibration. If the vibration is too great, the crankshaft will be damaged. The vibration damper limits the torsional vibrations to an acceptable amount in order to prevent damage to the crankshaft.

Rubber Vibration Damper

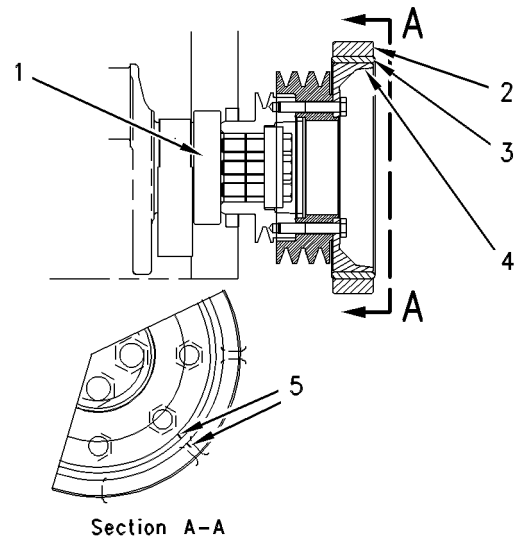

Illustration 39 g00293231

Rubber vibration damper

- (1) Crankshaft
- (2) Ring
- (3) Rubber ring
- (4) Hub
- (5) Alignment marks

The rubber vibration damper is installed on the front of crankshaft (1). The hub (4) and ring (2) are isolated by a rubber ring (3). The rubber vibration damper has alignment marks (5) on the hub and the ring. These marks give an indication of the condition of the rubber vibration damper.

Camshaft

The camshaft is located in the upper left side of the cylinder block. The camshaft is driven by gears at the front of the engine. Seven bearings support the camshaft. A thrust plate is mounted between the camshaft drive gear and a shoulder of the camshaft in order to control the end play of the camshaft.

The camshaft is driven by an idler gear which is driven by the crankshaft gear. The camshaft rotates in the same direction as the crankshaft. The crankshaft rotates in the counterclockwise direction when the engine is viewed from the flywheel end of the engine. There are timing marks on the crankshaft gear, the idler gear, and the camshaft gear in order to ensure the correct camshaft timing to the crankshaft for proper valve operation.

As the camshaft turns, each lobe moves a lifter assembly. There are two lifter assemblies for each cylinder. Each lifter assembly moves a pushrod. Each pushrod moves a valve (exhaust) or a set of valves (inlet). The camshaft must be in time with the crankshaft. The relation of the camshaft lobes to the crankshaft position causes the valves in each cylinder to operate at the correct time.

i01854525

Electrical System

SMCS Code: 1400; 1550; 1900

Grounding Practices

Proper grounding for the vehicle electrical system and the engine electrical systems is necessary for proper vehicle performance and reliability. Improper grounding will result in unreliable electrical circuit paths and uncontrolled electrical circuit paths.

Uncontrolled engine electrical circuit paths can result in damage to main bearings, crankshaft bearing journal surfaces, and aluminum components.

Uncontrolled electrical circuit paths can cause electrical noise which may degrade the vehicle and radio performance.

To ensure proper functioning of the vehicle and engine electrical systems, an engine-to-frame ground strap with a direct path to the battery must be used. This may be provided by a starting motor ground, by a frame to starting motor ground, or by a direct frame to engine ground. An engine-to-frame ground strap must be used in order to connect the grounding stud of the engine to the frame of the vehicle and to the negative battery post.

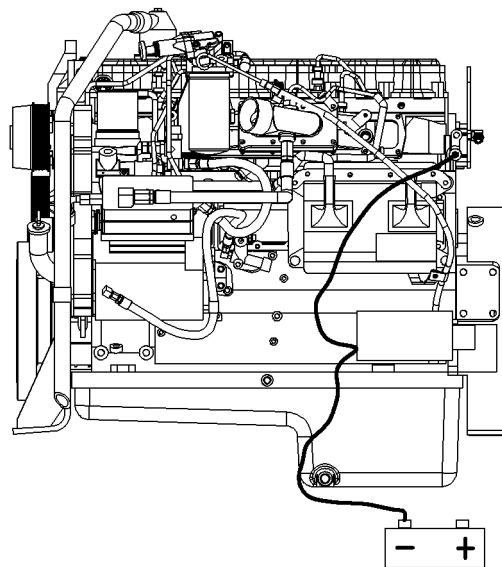

Illustration 40

g00769833

Grounding Stud To Battery Ground (“-”)

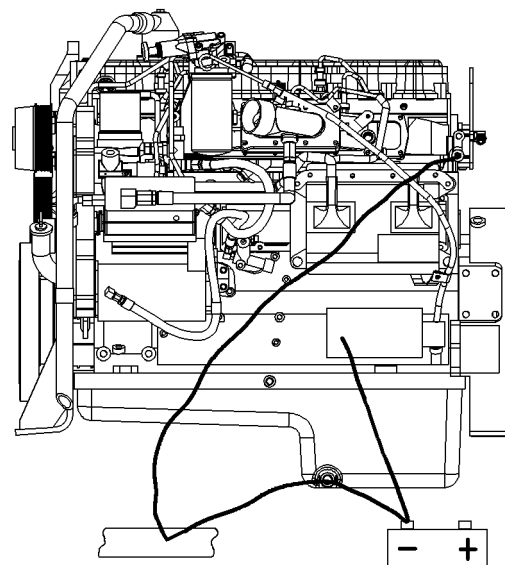

Illustration 41

g00769834

Alternate Grounding Stud To Battery Ground (“-”)

The engine must have a wire ground to the battery.

Ground wires or ground straps should be combined at ground studs that are only for ground use. The engine grounds should be inspected after every 20125 km (12,500 miles) or every 250 hours. All of the grounds should be tight and free of corrosion.

The engine alternator should be battery ground with a wire size that is capable of managing the full charging current of the alternator.

NOTICE

When boost starting an engine, the instructions in Systems Operation, "Engine Starting" should be followed in order to properly start the engine.

This engine may be equipped with a 12 volt starting system or a 24 volt starting system. Only equal voltage for boost starting should be used. The use of a higher voltage will damage the electrical system.

The Electronic Control Module (ECM) must be disconnected at the "J1/P1" and "J2/P2" locations before welding on the vehicle.

Engine Electrical System

The electrical system has three separate circuits:

- Charging circuit
- Starting circuit
- Low amperage circuit

Some of the electrical system components are used in more than one circuit. The following components are used in each of the three circuits:

- Battery
- Circuit breaker
- Ammeter
- Battery cables

The charging circuit is in operation when the engine is running. An alternator generates electricity for the charging circuit. A voltage regulator in the circuit controls the electrical output in order to keep the battery at full charge.

NOTICE

The disconnect switch, if equipped, must be in the ON position in order to let the electrical system function. There will be damage to some of the charging circuit components if the engine is running with the disconnect switch in the OFF position.

If the vehicle has a disconnect switch, the starting circuit can operate only after the disconnect switch is put in the ON position.

The starting circuit is in operation only when the start switch is activated.

Both the low amperage circuit and the charging circuit are connected to the same side of the ammeter. The starting circuit is connected to the opposite side of the ammeter.

NOTICE

Never operate the alternator without the battery in the circuit. Making or breaking an alternator connection with heavy load on the circuit can cause damage to the regulator.

Testing and Adjusting Section

Fuel System

Fuel System - Inspect

i01334705

SMCS Code: 1250-040

Initial Inspection Of The Fuel System

A problem with the components that send fuel to the engine can cause low fuel pressure. This can decrease engine performance.

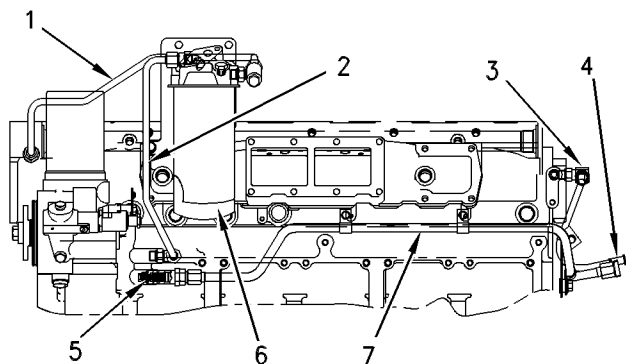

Illustration 42

g00296730

Fuel System

- (1) Tube assembly (fuel filter to fuel supply passage)
- (2) Tube assembly (fuel transfer pump to fuel filter)
- (3) Pressure regulator
- (4) Tube assembly (tank return line)
- (5) Fuel inlet port (fuel transfer pump)
- (6) Fuel filter
- (7) Tube assembly

1. Check the fuel level in the fuel tank. Inspect the cap for the fuel tank. Ensure that the vent in the fuel cap is not filled with dirt.
2. Check all fuel lines for fuel leakage. The fuel lines must be free from restrictions and faulty bends. Verify that the fuel return line is not collapsed.
3. Clean the screen inside the inlet fitting of the fuel transfer pump.
4. Operate the hand priming pump (if equipped). If excessive resistance is felt, inspect the fuel pressure regulating valve (3). Make sure that the pressure regulator (3) is installed correctly, and make sure that the pressure regulator functions correctly.

5. Install a new fuel filter (6).
6. Cut the old filter open with the 4C-5084 Oil Filter Cutter. Inspect the filter for excess contamination. Determine the source of the contamination. Make the necessary repairs.
7. Service the primary fuel filter (if equipped).
8. Operate the hand priming pump (if equipped). If uneven resistance is felt, test for air in the fuel. Refer to Testing and Adjusting, "Air in Fuel - Test" for more information.
9. Remove any air that may be in the fuel system. Refer to Testing and Adjusting, "Fuel System - Prime".

Start Up Procedure

Note: Refer to Operation and Maintenance Manual, "Engine Starting" in the Operation Section.

After work has been done on the fuel system, consider the following precautions before you start the engine. Make sure that you use this starting procedure to start the engine only after the fuel system has been worked on:

1. Disconnect the air inlet system from the turbocharger.

WARNING

Be careful when placing the steel plate against the opening on the turbocharger air inlet. To avoid crushed fingers, do not position fingers between the steel plate and the opening on the turbocharger air inlet. Due to excessive suction, the plate can be forcefully pulled against the opening on the turbocharger air inlet.

2. Another person will need to help as a precautionary step. This person should be ready to use the steel plate to cover the turbocharger air inlet if a problem occurs.

Note: Make sure that the steel plate is large enough to cover the entire turbocharger air inlet.

3. Start the engine.

Immediately place the steel plate against the opening on the turbocharger air inlet, if the engine operates in one of the following ways:

- The engine runs too fast.
- The engine runs out of control.

Covering the opening will stop the air supply to the engine, so the engine will stop.

Inspection With The Engine Running

Either too much fuel for combustion or not enough fuel for combustion can be the cause of a problem in the fuel system. Finding the source of the problem can be difficult, especially when you have smoke that rises from the exhaust. Therefore, work is often done on the fuel system when the problem is really with some other part of the engine.

When noticeable smoke rises from the exhaust, this problem can be caused by a damaged unit injector. This unusual smoke can also be caused by one or more of the reasons that follow:

- not enough air for good combustion
- an overload at high altitude
- oil leakage into combustion chamber
- altitude
- air inlet and exhaust leaks

Note: Refer to Troubleshooting for more information on the fuel system.

Checking The Operation Of Individual Cylinders

Low temperature at an exhaust manifold port is an indication of no fuel to the cylinder. This can possibly be an indication of an injector with a defect. An extra high temperature at an exhaust manifold port can be an indication of too much fuel to the cylinder. High temperatures may also be caused by an injector with a defect.

Refer to Testing And Adjusting, "Exhaust Temperature - Test" for the procedure for checking the temperatures in the exhaust manifold port.

Air in Fuel - Test

SMCS Code: 1280-081

This procedure checks for air in the fuel. This procedure also assists in finding the source of the air.

1. Examine the fuel system for leaks. Ensure that the fuel line fittings are properly tightened. Check the fuel level in the fuel tank. Air can enter the fuel system on the suction side between the fuel transfer pump and the fuel tank.

2. Install a 2P-8278 Fuel Flow Tube (Sight Gauge) in the fuel return line. When possible, install the sight gauge in a straight section of the fuel line that is at least 304.8 mm (12 inches) long. Do not install the sight gauge near the following devices that create turbulence:

- Elbows
- Relief valves
- Check valves

Observe the fuel flow during engine cranking. Look for air bubbles in the fuel. If there is no fuel in the sight gauge, prime the fuel system. Refer to Testing and Adjusting, "Fuel System - Prime" for more information. If the engine starts, check for air in the fuel at varying engine speeds. When possible, operate the engine under the conditions which have been suspect of air in the fuel.

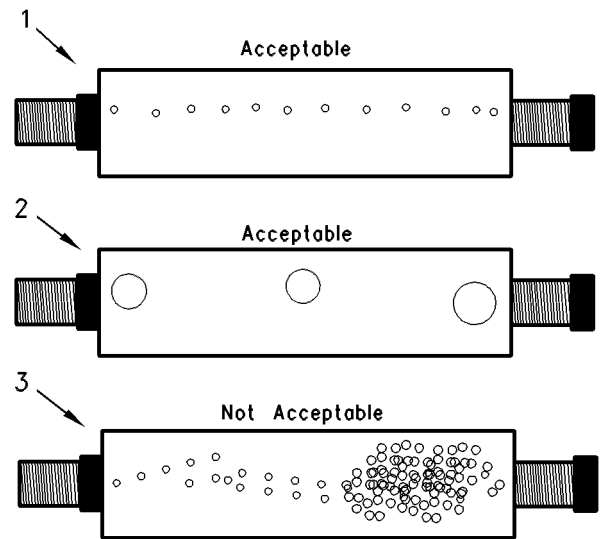

Illustration 43

g00578151

2P-8278 Fuel Flow Tube (Sight Gauge)

- (1) A steady stream of small bubbles with a diameter of approximately 1.60 mm (0.063 inch) is an acceptable amount of air in the fuel.
- (2) Bubbles with a diameter of approximately 6.35 mm (0.250 inch) are also acceptable if there is two seconds to three seconds intervals between bubbles.
- (3) Excessive air bubbles in the fuel are not acceptable.

- If excessive air is seen in the sight gauge in the fuel return line, install a second sight gauge at the inlet to the fuel transfer pump. If a second sight gauge is not available, move the sight gauge from the fuel return line and install the sight gauge at the inlet to the fuel transfer pump. Observe the fuel flow during engine cranking. Look for air bubbles in the fuel. If the engine starts, check for air in the fuel at varying engine speeds.

If excessive air is not seen at the inlet to the fuel transfer pump, the air is entering the system after the fuel transfer pump. Proceed to Step 6.

If excessive air is seen at the inlet to the fuel transfer pump, air is entering through the suction side of the fuel system.

WARNING

To avoid personal injury, always wear eye and face protection when using pressurized air.

NOTICE

To avoid damage, do not use more than 55 kPa (8 psi) to pressurize the fuel tank.

- Pressurize the fuel tank to 35 kPa (5 psi). Do not use more than 55 kPa (8 psi) in order to avoid damage to the fuel tank. Check for leaks in the fuel lines between the fuel tank and the fuel transfer pump. Repair any leaks that are found. Check the fuel pressure in order to ensure that the fuel transfer pump is operating properly. For information about checking the fuel pressure, see Testing and Adjusting, "Fuel System Pressure - Test".
- If the source of the air is not found, disconnect the supply line from the fuel tank and connect an external fuel supply to the inlet of the fuel transfer pump. If this corrects the problem, repair the fuel tank or the stand pipe in the fuel tank.
- If the injector sleeve is worn or damaged, combustion gases may be leaking into the fuel system. Also, if the O-rings on the injector sleeves are worn, missing, or damaged, combustion gases may leak into the fuel system.

Engine Speed - Check

SMCS Code: 1000

Table 3

Tools Needed		
Part Number	Part Name	Quantity
1U-6602 or 9U-7400	Photo-Tachometer ⁽¹⁾ or Multitach Tool Group	1

⁽¹⁾ This unit is a hand-held service tool.

Note: The Electronic Service Tools can also be used.

You can observe the engine rpm, which is displayed on the status screen of the electronic service tool.

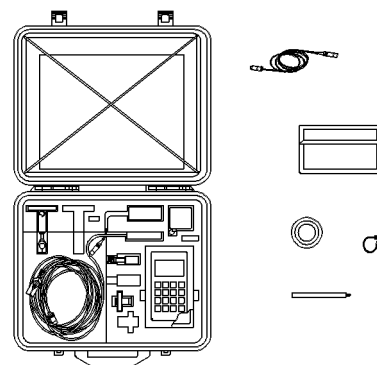

Illustration 44

g00286276

9U-7400 Multitach Tool Group

The 9U-7400 Multitach Tool Group can measure engine rpm from a magnetic pickup. This magnetic pickup is located in the flywheel housing. The multitach also uses the ability to measure engine rpm from visual engine parts that are rotating.

Note: Refer to Special Instruction, NEHS0605 that is with the 9U-7400 Multitach Tool Group. This manual gives instructions for the test procedure.

The 1U-6602 Photo-Tachometer is a phototach for general use. This tachometer can only register the basic input frequency on any rotating part that is visible. The basic input frequency is 1 pulse per revolution per piece of reflective tape.

Note: Refer to Special Instruction, SEHS8854 that is with this group. This manual provides instructions for using this tool.

Note: The measurement of engine rpm can be set with the Electronic Service Tool. Refer to Electronic Troubleshooting.

i01626172

Finding Top Center Position for No. 1 Piston

SMCS Code: 1105-531

Table 4

Required Tools		
Part Number	Description	Qty
136-4632	Timing Pin	1
139-7064	Timing Pin Adapter	1
9S-9082	Engine Turning Tool	1

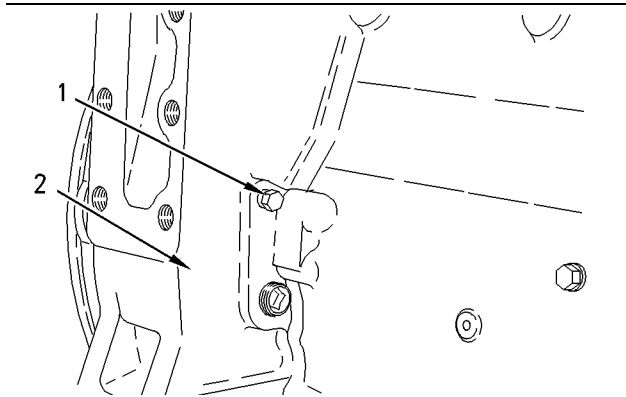

Illustration 45

g00842050

Timing Hole Location (Typical Example)

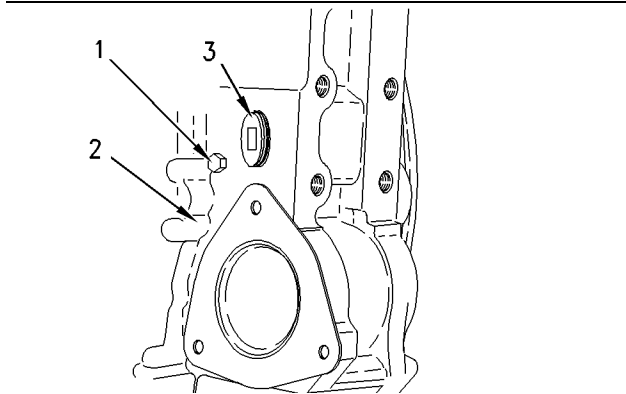

Illustration 46

g00842034

Timing Hole Location (Typical Example)

Note: The hole for the timing pin can be in one of two positions:

- The right front face of the flywheel housing (Illustration 45)
- The left front face of the flywheel housing (Illustration 46)

1. Remove plug (1) from flywheel housing (2). Install timing pin through timing hole in the flywheel housing.

Note:

- 2.

Remove plug (3). Use the engine turning tool in order to turn the engine. Do not use the eight small bolts on the front of the crankshaft pulley.

Turn the flywheel in the direction of normal engine rotation. Turn the flywheel until the timing pin engages with the hole in the flywheel.

Note: If the flywheel is turned beyond the point of engagement, the flywheel must be turned in the direction that is opposite of normal engine rotation. Turn the flywheel by approximately 30 degrees. Then turn the flywheel in the direction of normal engine rotation until the timing pin engages with the threaded hole. When the No. 1 piston is at the top center position, this procedure will remove the play from the gears.

3. Remove the valve cover.

The inlet valves and the exhaust valve for the No. 1 cylinder are fully closed under two conditions:

- No. 1 piston is on the compression stroke.
- The rocker arms can be moved by hand.

If the rocker arms cannot be moved and the valves are slightly open, the No. 1 piston is on the exhaust stroke.

Note: Refer to Testing And Adjusting, "Crankshaft Positions for Valve Lash Setting".

4. After the timing bolt has been installed in the flywheel, complete these procedures, as required:
 - a. Find the cylinders that need to be checked for the stroke position of the crankshaft.
 - b. Find the cylinders that need to be adjusted for the stroke position of the crankshaft.
5. When the actual stroke position is identified and the other stroke position is needed, remove the timing bolt from the flywheel.
6. Turn the flywheel by 360 degrees in the direction of normal engine rotation.

Note: The timing hole is used during the procedure to set the valve lash.

i01370330

Fuel Quality - Test

SMCS Code: 1280-081

This test checks for problems regarding fuel quality. Refer to Diesel Fuels and Your Engine, SEBD0717 for additional details.

Use the following procedure to test for problems regarding fuel quality:

1. Determine if water and/or contaminants are present in the fuel. Check the water separator (if equipped). If a water separator is not present, proceed to Step 2. Drain the water separator, if necessary. A full fuel tank minimizes the potential for overnight condensation.

Note: A water separator can appear to be full of fuel when the water separator is actually full of water.

2. Determine if contaminants are present in the fuel. Remove a sample of fuel from the bottom of the fuel tank. Visually inspect the fuel sample for contaminants. The color of the fuel is not necessarily an indication of fuel quality. However, fuel that is black, brown, and/or similar to sludge can be an indication of the growth of bacteria or oil contamination. In cold temperatures, cloudy fuel indicates that the fuel may not be suitable for operating conditions. The following methods can be used to prevent wax from clogging the fuel filter:
 - Fuel heaters
 - Blending fuel with additives
 - Utilizing fuel with a low cloud point such as kerosene

- Fuel heaters

- Blending fuel with additives

- Utilizing fuel with a low cloud point such as kerosene

Refer to Operation and Maintenance Manual, "Fuel Recommendations" for more information.

3. Check fuel API with a **9U-7840** Fluid and Fuel Calibration Gp for low power complaints. The acceptable range of the fuel API is 30 to 45 when the API is measured at 15 °C (60 °F), but there is a significant difference in energy within this range. Refer to Tool Operating Manual, NEHS0607 for API correction factors when a low power problem is present and API is high.

Note: A correction factor that is greater than 1.000 may be the cause of low power and/or poor fuel consumption.

4. If fuel quality is still suspected as a possible cause to problems regarding engine performance, disconnect the fuel inlet line, and temporarily operate the engine from a separate source of fuel that is known to be good. This will determine if the problem is caused by fuel quality. If fuel quality is determined to be the problem, drain the fuel system and replace the fuel filters. Engine performance can be affected by the following characteristics :
 - Cetane number of the fuel
 - Air in the fuel
 - Other fuel characteristics

- Cetane number of the fuel

- Air in the fuel

- Other fuel characteristics

i01823195

Fuel System - Prime

SMCS Code: 1258-548

WARNING

Fuel leaked or spilled onto hot surfaces or electrical components can cause a fire. To help prevent possible injury, turn the start switch off when changing fuel filters or water separator elements. Clean up fuel spills immediately.

If the engine's fuel system is run dry, fill the fuel tank. Then prime the fuel system in order to remove any air bubbles from the system.

NOTICE

Do not loosen fuel lines at the fuel manifold. The engine components may be damaged and/or loss of priming pressure may occur when the fuel lines are loosened.

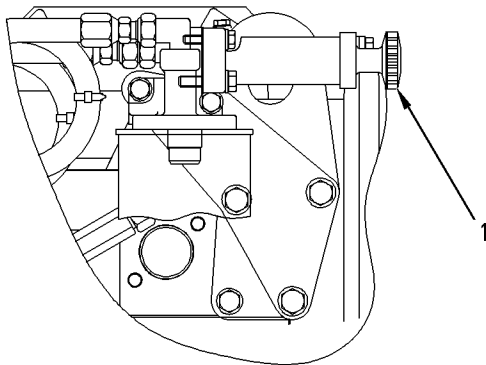

Illustration 47 g00936682
Typical example

Follow these steps in order to prime the fuel system:

1. Locate the fuel priming pump.
2. Operate priming pump's plunger (1) in order to fill the final fuel filter. Continue until you feel resistance.

Note: You may need to pump the priming pump for 25 times or more in order to fill the fuel filter. Furthermore, you may need up to 75 pump strokes to fill the fuel supply passage.

3. Push the plunger and tighten the plunger in a counterclockwise direction. Tighten the plunger by hand.
4. After you pressurize the fuel system, promptly crank the engine.

Note: Use the engine starting procedure. Refer to Operation and Maintenance Manual, "Engine Starting" in the Operation Section.

Fuel System Pressure - Test

SMCS Code: 1250-081; 1256-081

Table 5

Tools Needed		
Part Number	Part Name	Quantity
1U-5470 or 198-4240	Engine Pressure Test Group or Pressure Indicator Tool Gp	1
3Y-2888	Connector	1
3J-1907	O-Ring Seal	1

Note: Both the 5P-2720 Probe Adapter and the 5P-2718 Pressure Probe can be used with these tools. Use these additional tools to allow the future installation of pressure probes.

WARNING

Fuel leaked or spilled onto hot surfaces or electrical components can cause a fire. Clean up fuel spills immediately.

NOTICE

Keep all parts clean from contaminants.

Contaminants may cause rapid wear and shortened component life.

NOTICE

Care must be taken to ensure that fluids are contained during performance of inspection, maintenance, testing, adjusting and repair of the product. Be prepared to collect the fluid with suitable containers before opening any compartment or disassembling any component containing fluids.

Refer to Special Publication, NENG2500, "Caterpillar Tools and Shop Products Guide" for tools and supplies suitable to collect and contain fluids on Caterpillar products.

Dispose of all fluids according to local regulations and mandates.

The 1U-5470 Engine Pressure Test Group or the 198-4240 Pressure Indicator Tool Gp can be used in order to check the engine's fuel pressures.

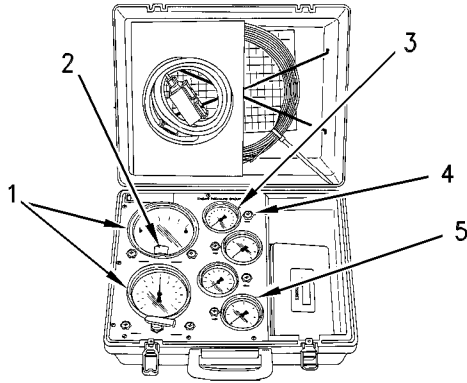

Illustration 48 g00284796
1U-5470 Engine Pressure Test Group
(1) Pressure indicators. (2) Zero adjustment screw. (3) Pressure indicator. (4) Pressure tap. (5) Pressure indicator.

This tool group has a gauge that is used to register the pressure in the fuel manifolds. The Special Instruction, SEHS8907 is with the tool group.

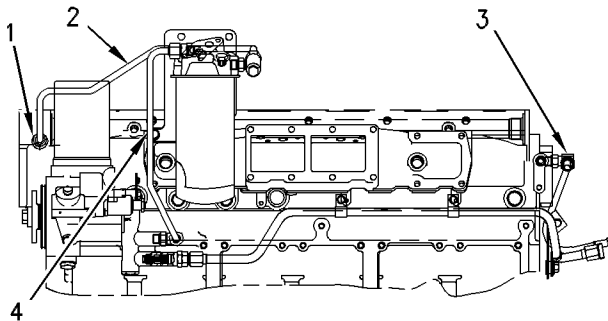

Illustration 49 g00296502
Fuel Return Line (Typical Example)
(1) Fuel supply passage. (2) Tube assembly (CPU to fuel supply passage). (3) Pressure regulator. (4) Tube assembly (fuel transfer pump to fuel filter).

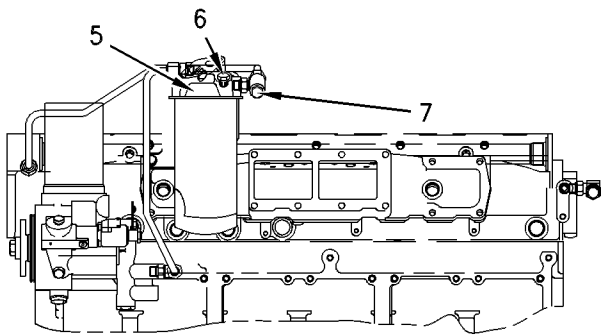

Illustration 50 g00296503
Fuel Pressure Test (Typical Example)
(5) Fuel filter base. (6) Fuel pressure tap (unfiltered tap). (7) Fuel pressure tap (filtered tap).

During both normal operating conditions and load conditions, the fuel pressure should register the following range:

- 400 to 525 kPa (58 to 76 psi)

At low idle, the fuel pressure at the fuel filter's inlet should be at the following amount:

- 400 to 435 kPa (58 to 63 psi)

The fuel pressure to fuel supply passage (1) should be the same amount, if you subtract the change in pressure (delta P) across the filter.

With a new filter, the pressure drop across the fuel filter typically registers the following amount:

- 35 kPa (5 psi)

As abrasive particles collect in the fuel filter, the pressure differential across the filter will increase. When a filter becomes plugged, fuel supply pressure may drop as low as 69 kPa (10 psi) before a significant power loss is detected by the operator. Low fuel pressure will cause cavitation and internal damage to the unit injectors. **The pressure differential across the fuel filter should not exceed 69 kPa (10 psi).**

Pressure regulator (3) is mounted directly in the cylinder head. The regulator is located at the fuel return port toward the rear end of the fuel supply passage (1). The orifice maintains fuel pressure at low engine rpm.

To check the unfiltered fuel pressure, follow this procedure:

1. Remove the plug from fuel pressure tap (6).
2. Install the connector, the seal, and the engine pressure test group to fuel pressure tap (6).

This will obtain the fuel transfer pump pressure.

To check the fuel pressure in the fuel supply passage (1), follow these steps:

1. Remove the plug from fuel pressure tap (7).
2. Install the adapter, the seal, and the engine pressure test group to fuel pressure tap (7).
3. Operate the engine.

Note: Make sure that the fuel filter is clean before you check the fuel pressure. A restricted fuel filter causes lower fuel pressure at fuel pressure tap (7) than the fuel pressure at fuel pressure tap (6).

i01851185

i01280287

Gear Group (Front) - Time

SMCS Code: 1206-531

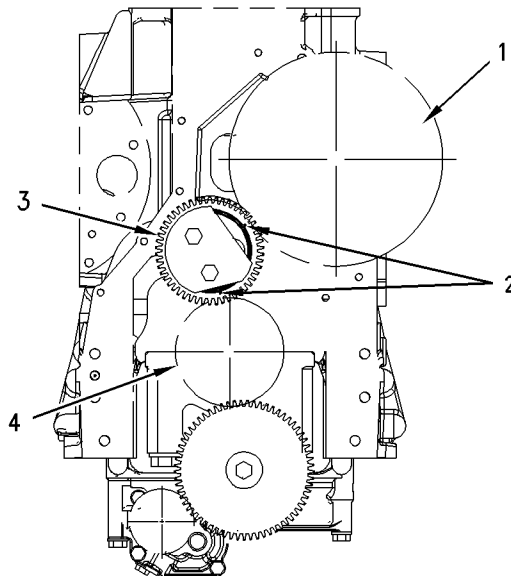

Illustration 51

g00943251

Front gear group

- (1) Camshaft gear and timing reference gear
- (2) Timing marks
- (3) Idler gear
- (4) Crankshaft gear

Correct fuel injection timing and correct valve mechanism operation is determined by the timing reference gear and the alignment of the front gear group. The timing reference gear is located on the camshaft gear. The timing reference gear is used to measure crankshaft rotation. During installation of the front gear, timing marks (2) on idler gear (3) must be in alignment with the timing marks on crankshaft gear (4) and the timing marks on camshaft gear (1).

Check the teeth on the timing reference gear. The teeth should not be defaced. The teeth should have sharp clean edges and the teeth should be free of contaminants.

Note: The electronic injection timing must be calibrated after reassembly of the front gear train. Refer to Troubleshooting, "Engine Speed/Timing Calibration".

Unit Injector - Test

SMCS Code: 1290-081

This procedure assists in identifying the cause for an injector misfiring. Perform this procedure only after performing the Cylinder Cutout Test. Refer to Troubleshooting, "Injector Solenoids Circuits Test" for more information.

1. Check for air in the fuel, if this procedure has not already been performed. Refer to Testing and Adjusting, "Air in Fuel - Test".

WARNING

Electrical shock hazard. The electronic unit injector system uses 90-120 volts.

2. Remove the valve cover and look for broken parts. Repair any broken parts or replace any broken parts that are found. Inspect all wiring for the solenoids. Look for loose connections. Also look for frayed wires or broken wires. Ensure that the connector for the unit injector solenoid is properly connected. Perform a pull test on each of the wires.
3. Look for signs of fuel leakage. Investigate the source of the leaking fuel. Remedy the cause of the fuel leak.
4. Check the valve lash setting for the cylinder of the suspect unit injector. Refer to Testing and Adjusting, "Engine Valve Lash - Inspect/Adjust".
5. Ensure that the bolts that hold the unit injector are tightened to the proper torque. In order to check the torque, loosen the bolts that hold the unit injector. Tighten the bolts to the proper torque. Refer to either the Disassembly and Assembly Manual, "Unit Injector - Install" or the Specifications Manual, "Unit Injector - Install" for the proper tightening procedure.

6. Remove the suspect unit injector and check the unit injector for signs of exposure to coolant. Exposure to coolant will cause rust to form on the injector. If the unit injector shows signs of exposure to coolant, remove the injector sleeve and inspect the injector sleeve. Replace the injector sleeve if the injector sleeve is damaged. Check the unit injector for an excessive brown discoloration that extends beyond the injector tip. If excessive discoloration is found, check the quality of the fuel. Refer to Testing and Adjusting, "Fuel Quality - Test". Replace the seals on the injector and reinstall the injector. Refer to Disassembly and Assembly Manual, "Unit Injector - Install". Also refer to Disassembly and Assembly Manual, "Unit Injector Sleeve - Install". Inspect the injector for deposits of soot that are above the surface of the seat of the injector. Deposits of soot indicate combustion gas leakage. The source of the leak should be found, and the source of the leak should be remedied. The injector will not need to be replaced if combustion gas leakage was the problem.
7. If the problem is not resolved, replace the suspect injector with a new injector. In order to verify that the new injector is working properly, perform the Cylinder Cutout Test. Use the Caterpillar Electronic Technician (ET).

Air Inlet and Exhaust System

i01854769

Air Inlet and Exhaust System - Inspect

SMCS Code: 1050-040

Air Inlet Restriction

There will be a reduction in the performance of the engine if there is a restriction in the air inlet system or the exhaust system.

Table 6

Required Tools		
Part Number	Part Name	Quantity
1U-5470 or 198-4240	Engine Pressure Group or Digital Pressure Indicator	1

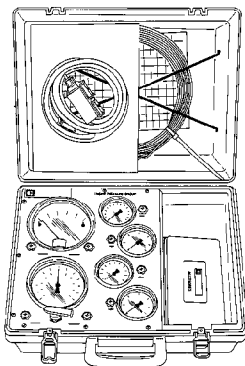

Illustration 52

g00293196

1U-5470 Engine Pressure Group

Refer to Special Instruction, SEHS8907, "Using the 1U-5470 Engine Pressure Group" for the instructions that are needed to use the 1U-5470 Engine Pressure Group. Refer to Operation Manual, NEHS0818, "Using the 198-4240 Pressure Indicator Tool Gp" for the instructions that are needed to use the 198-4240 Pressure Indicator Tool Gp.

1. Inspect the engine air cleaner inlet and ducting in order to ensure that the passageway is not blocked or collapsed.
2. Inspect the engine air cleaner element. Replace a dirty engine air cleaner element with a clean engine air cleaner element.

3. Check for dirt tracks on the clean side of the engine air cleaner element. If dirt tracks are observed, contaminants are flowing past the engine air cleaner element and/or the seal for the engine air cleaner element.

WARNING

Hot engine components can cause injury from burns. Before performing maintenance on the engine, allow the engine and the components to cool.

WARNING

Making contact with a running engine can cause burns from hot parts and can cause injury from rotating parts.

When working on an engine that is running, avoid contact with hot parts and rotating parts.

4. Use the differential pressure gauge of the 1U-5470 Engine Pressure Group.

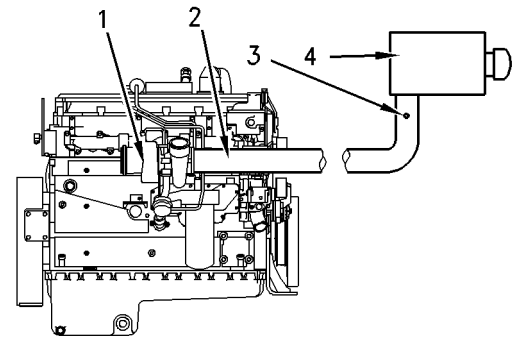

Illustration 53

g00678913

Typical example

- (1) Turbocharger
- (2) Air inlet piping
- (3) Test location
- (4) Air cleaner

- a. Connect the vacuum port of the differential pressure gauge to test location (3). Test location (3) can be located anywhere along air inlet piping (2) after engine air cleaner (4) but before turbocharger (1).
- b. Leave the pressure port of the differential pressure gauge open to the atmosphere.
- c. Start the engine. Run the engine in the no-load condition at high idle.
- d. Record the value.

- e. Multiply the value from Step 4.d by 1.8.
- f. Compare the result from Step 4.e to the appropriate values that follow.

The air flow through a used engine air cleaner may have a restriction. The air flow through a plugged engine air cleaner will be restricted to some magnitude. In either case, the restriction must not be more than the following amount:

Maximum restriction 6.2 kPa (25 inch of H₂O)

The air flow through a new engine air cleaner element must not have a restriction of more than the following amount:

Maximum restriction 3.7 kPa (15 inch of H₂O)

Exhaust Restriction

⚠ WARNING

The muffler and converter will become extremely hot during engine operation. A hot muffler and converter can cause serious burns. Allow adequate cooling time before working on or near the muffler and converter.

Excessive idling can cause the catalytic converter/muffler to plug. A plugged catalytic converter/muffler will lead to an increase in exhaust back pressure. Operating the engine in extremely cold conditions may cause the catalytic converter/muffler to plug. One indication of a plugged catalytic converter/muffler is poor engine response.

If the engine is operated at low idle or at low load for 24 or more consecutive hours, the engine should be run at rated conditions for five to fifteen minutes. Running the engine at rated conditions should clean out the catalytic converter/muffler.

Exhaust Back Pressure

Back pressure is the difference in the pressure between the exhaust and the atmospheric air.

Table 7

Required Tools		
Part Number	Part Name	Quantity
1U-5470 or 198-4240	Engine Pressure Group or Digital Pressure Indicator	1

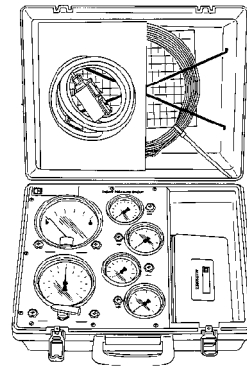

Illustration 54

g00293196

1U-5470 Engine Pressure Group

Refer to Special Instruction, SEHS8907, "Using the 1U-5470 Engine Pressure Group" for the instructions that are needed to use the 1U-5470 Engine Pressure Group. Refer to Operation Manual, NEHS0818, "Using the 198-4240 Pressure Indicator Tool Gp" for the instructions that are needed to use the 198-4240 Pressure Indicator Tool Gp.

⚠ WARNING

Hot engine components can cause injury from burns. Before performing maintenance on the engine, allow the engine and the components to cool.

⚠ WARNING

Making contact with a running engine can cause burns from hot parts and can cause injury from rotating parts.

When working on an engine that is running, avoid contact with hot parts and rotating parts.

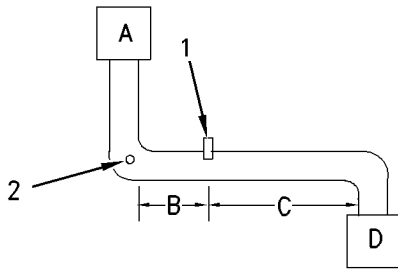

Illustration 55

g00780838

- (A) Catalytic converter/muffler
- (B) 152 mm (6 inches)
- (C) 305 mm (12 inches)
- (D) Turbocharger or exhaust manifold
- (1) Preferred test location
- (2) Optional test location

The location of the back pressure tap is important in order to obtain an accurate back pressure reading. The test location should be located on a straight length of exhaust pipe. This back pressure tap should be located as close as possible to the turbocharger or the exhaust manifold. The tap should be located at least 305 mm (12 inches) downstream of a bend. The tap should have 152 mm (6 inches) before a bend. If a continuous straight length of exhaust that is 457 mm (18 inches) is not available, the tap should be located as close as possible to the neutral axis on an elbow.

If the exhaust is not equipped with a back pressure tap, the following procedure may be used in order to install a pressure tap.

1. Mark the position for the pressure tap.
2. Weld or braze a 1/8 inch NPT half coupling to the exhaust pipe.
3. Drill a 3.18 mm (0.125 inch) hole through the wall of the exhaust inside the half coupling.
4. Remove any burrs from the inside of the exhaust pipe.

Use the differential pressure gauge of the 1U-5470 Engine Pressure Group in order to measure back pressure from the exhaust. Use the following procedure in order to measure back pressure from the exhaust:

Catalytic Converter/Muffler

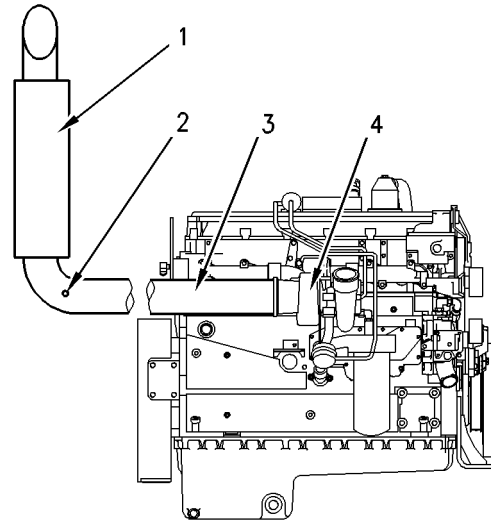

Illustration 56

g00678914

Typical example

- (1) Catalytic converter/muffler
- (2) Test location
- (3) Exhaust piping
- (4) Turbocharger

1. Connect the pressure port of the differential pressure gauge to the test location. The test location should be located on a straight length of exhaust pipe. This back pressure tap should be located as close as possible to the turbocharger or the exhaust manifold.
2. Leave the vacuum port of the differential pressure gauge open to the atmosphere.
3. Start the engine. Run the engine in the no-load condition at high idle until the engine reaches normal operating temperature.
4. Record the value.
5. Multiply the value from Step 4 by 1.8.
6. Compare the result from Step 5 to the value that follows.

Maximum back pressure for engines without a catalytic converter/muffler 10.0 kPa
(40 inch of H₂O)

Maximum back pressure for catalytic converter/muffler 14.9 kPa (60 inch of H₂O)

If the maximum back pressure is within the allowable limits, refer to Troubleshooting, "Low/Power/Poor or No Response to Throttle".

If the back pressure exceeds 14.9 kPa (60 inch of H₂O), replace the catalytic converter/muffler.

i01388605

Turbocharger - Inspect

SMCS Code: 1052-040

WARNING

Disconnect batteries before performance of any service work.

WARNING

Hot engine components can cause injury from burns. Before performing maintenance on the engine, allow the engine and the components to cool.

WARNING

Personal injury can result from rotating and moving parts.

Stay clear of all rotating and moving parts.

Never attempt adjustments while the machine is moving or the engine is running unless otherwise specified.

The machine must be parked on a level surface and the engine stopped.

NOTICE

Keep all parts clean from contaminants.

Contaminants may cause rapid wear and shortened component life.

NOTICE

Care must be taken to ensure that fluids are contained during performance of inspection, maintenance, testing, adjusting and repair of the product. Be prepared to collect the fluid with suitable containers before opening any compartment or disassembling any component containing fluids.

Refer to Special Publication, NENG2500, "Caterpillar Tools and Shop Products Guide" for tools and supplies suitable to collect and contain fluids on Caterpillar products.

Dispose of all fluids according to local regulations and mandates.

Before you begin inspection of the turbocharger, be sure that the inlet air restriction is within the specifications for your engine. Be sure that the exhaust system restriction is within the specifications for your engine. Refer to Systems Operation/Testing and Adjusting, "Air Inlet and Exhaust System - Inspect".

The condition of the turbocharger will have definite effects on engine performance. Use the following inspections and procedures to determine the condition of the turbocharger.

- Inspection of the Compressor and the Compressor Housing
- Inspection of the Turbine Wheel and the Turbine Housing
- Inspection of the Wastegate

Inspection of the Compressor and the Compressor Housing

Remove air piping from the compressor inlet.

1. Inspect the compressor wheel for damage from a foreign object. If there is damage, determine the source of the foreign object. As required, clean the inlet system and repair the intake system. Replace the turbocharger. If there is no damage, go to Step 3.
2. Clean the compressor wheel and clean the compressor housing if you find buildup of foreign material. If there is no buildup of foreign material, go to Step 3.
3. Turn the rotating assembly by hand. While you turn the assembly, push the assembly sideways. The assembly should turn freely. The compressor wheel should not rub the compressor housing. Replace the turbocharger if the compressor wheel rubs the compressor wheel housing. If there is no rubbing or scraping, go to Step 4.
4. Inspect the compressor and the compressor wheel housing for oil leakage. An oil leak from the compressor may deposit oil in the aftercooler. Drain and clean the aftercooler if you find oil in the aftercooler.
 - a. Check the oil level in the crankcase. If the oil level is too high, adjust the oil level.
 - b. Inspect the air cleaner element for restriction. If restriction is found, correct the problem.
 - c. Inspect the engine crankcase breather. Clean the engine crankcase breather or replace the engine crankcase breather if the engine crankcase breather is plugged.

- d. Remove the turbocharger oil drain line. Inspect the drain opening. Inspect the oil drain line. Inspect the area between the bearings of the rotating assembly shaft. Look for oil sludge. Inspect the oil drain hole for oil sludge. Inspect the oil drain line for oil sludge in the drain line. If necessary, clean the rotating assembly shaft. If necessary, clean the oil drain hole. If necessary, clean the oil drain line.
- e. If Steps 4.a through 4.d did not reveal the source of the oil leakage, the turbocharger has internal damage. Replace the turbocharger.

Inspection of the Turbine Wheel and the Turbine Housing

Remove the air piping from the turbine outlet casing.

1. Inspect the turbine for damage by a foreign object. If there is damage, determine the source of the foreign object. Replace the turbocharger. If there is no damage, go to Step 2.
2. Inspect the turbine wheel for buildup of carbon and other foreign material. Inspect the turbine housing for buildup of carbon and foreign material. Clean the turbine wheel and clean the turbine housing if you find buildup of carbon or foreign material. If there is no buildup of carbon or foreign material, go to Step 3.
3. Turn the rotating assembly by hand. While you turn the assembly, push the assembly sideways. The assembly should turn freely. The turbine wheel should not rub the turbine wheel housing. Replace the turbocharger if the turbine wheel rubs the turbine wheel housing. If there is no rubbing or scraping, go to Step 4.
4. Inspect the turbine and the turbine wheel housing for oil leakage. Inspect the turbine and the turbine wheel housing for oil coking. Some oil coking may be cleaned. Heavy oil coking may require replacement of the turbocharger. If the oil is coming from the turbocharger center housing go to Step 4.a. Otherwise go to "Inspection of the Wastegate".
 - a. Remove the turbocharger oil drain line. Inspect the drain opening. Inspect the area between the bearings of the rotating assembly shaft. Look for oil sludge. Inspect the oil drain hole for oil sludge. Inspect the oil drain line for oil sludge. If necessary, clean the rotating assembly shaft. If necessary, clean the drain opening. If necessary, clean the drain line.

- b. If crankcase pressure is high, or if the oil drain is restricted, pressure in the center housing may be greater than the pressure of the turbine housing. Oil flow may be forced in the wrong direction and the oil may not drain. Check the crankcase pressure and correct any problems.
- c. If the oil drain line is damaged, replace the oil drain line.
- d. Check the routing of the oil drain line. Eliminate any sharp restrictive bends. Make sure that the oil drain line is not too close to the engine exhaust manifold.
- e. If Steps 4.a through 4.d did not reveal the source of the oil leakage, the turbocharger has internal damage. Replace the turbocharger.

Inspection of the Wastegate

The turbocharger senses boost pressure which actuates the wastegate valve. The wastegate valve controls the amount of exhaust gas that is allowed to bypass the turbine side of the turbocharger. Regulating the amount of exhaust gas that enters the turbocharger regulates the rpm of the turbocharger.

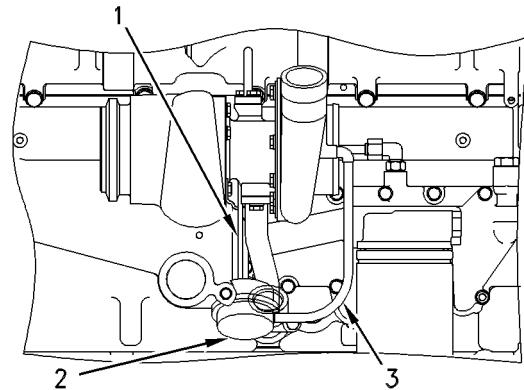

Illustration 57

g00295815

Typical Example

- (1) Actuating Rod
- (2) Canister
- (3) Line

When the engine operates in conditions of low boost (lug), a spring presses against a diaphragm in canister (2). This moves actuating rod (1) in order to close the wastegate valve. Then, the turbocharger can operate at maximum performance.

As the boost pressure increases against the diaphragm in canister (2), the wastegate valve opens. The rpm of the turbocharger becomes limited. This limitation occurs because a portion of the exhaust gases bypass the turbine wheel of the turbocharger.

The following levels of boost pressure indicate a problem with the wastegate valve:

- Too high at full load conditions
- Too low at all lug conditions

The Technical Marketing Information (TMI) provides the correct pressure for the inlet manifold.

To check the operation of the wastegate valve, verify the correct pressure for the wastegate valve. This can be accomplished by referring to the letter designation that is stamped on the actuating lever of the wastegate valve. This letter designation indicates a corresponding amount of pressure.

Note: Refer to Table 8 for the letter designation and the corresponding amounts of pressure.

Remove the air line, and slowly apply the corresponding amount of pressure to the canister. DO NOT EXCEED 200 kPa (29 psi).

When the external supply of air that is connected to line (3) reaches the corresponding pressure for the wastegate valve, the actuating lever should move by 0.50 ± 0.25 mm (0.020 ± 0.010 inch). If the actuating lever does NOT move by this amount, replace the turbine's housing assembly of the turbocharger. This housing assembly includes the wastegate valve. If necessary, replace the complete turbocharger.

Note: The housing assembly for the wastegate turbine is preset at the factory and no adjustments can be made.

Table 8

Amount Of Pressure That Is Required To Check The Wastegate Valve		
Letter Designation	kPa	psig
B	156	(23)
C	153	(22)
D	124	(18)
E	130	(19)
F	135	(20)
G	180	(26)
H	144	(21)
J	188	(27)
M	200	(29)
V	161	(23)
W	164	(24)

The boost pressure controls the maximum rpm of the turbocharger, because the boost pressure controls the position of the wastegate. The following factors also affect the maximum rpm of the turbocharger:

- Engine rating
- Horsepower demand on the engine
- High idle rpm
- Height above sea level for engine operation
- Inlet air restriction
- Exhaust system restriction

NOTICE

If the high idle rpm or the engine rating is higher than given in the Technical Marketing Information (TMI) for the height above sea level at which the engine is operated, there can be damage to engine or to turbocharger parts. Damage will result when increased heat and/or friction due to the higher engine output goes beyond the engine cooling and lubrication system's abilities.

i01665958

Inlet Manifold Pressure - Test

SMCS Code: 1058-081

The efficiency of an engine can be checked by making a comparison of the pressure in the inlet manifold with the information given in the TMI (Technical Marketing Information). The information is also listed on the Fuel Setting And Related Information Microfiche. This test is used when there is a decrease of horsepower from the engine, yet there is no real sign of a problem with the engine.

The correct pressure for the inlet manifold is listed in the TMI (Technical Marketing Information). The correct pressure is also on the Fuel Setting And Related Information Microfiche. Development of this information is performed under the following conditions:

- 96 kPa (28.8 in Hg) dry barometric pressure
- 25 °C (77 °F) outside air temperature
- 35 API rated fuel

Any change from these conditions can change the pressure in the inlet manifold. The outside air may have a higher temperature and a lower barometric pressure than the values that are given above. This will cause a lower inlet manifold pressure measurement than the pressure in the TMI. Outside air that has both a lower temperature and a higher barometric pressure will cause a higher inlet manifold pressure measurement.

A difference in fuel density will change horsepower (stall speed) and boost. If the fuel is rated above 35 API, the pressure in the inlet manifold can be less than the pressure that appears in the TMI. If the fuel is rated below 35 API, the pressure in the inlet manifold can be more than the pressure that appears in the TMI. **BE SURE THAT THE AIR INLET OR THE EXHAUST DOES NOT HAVE A RESTRICTION WHEN YOU ARE MAKING A CHECK OF THE PRESSURE.**

Note: The electronic service tool may be used to check the pressure in the inlet manifold.

Table 9

Tools Needed		
Part Number	Part Description	Qty
1U-5470 or 198-4240	Engine Pressure Test Group or Pressure Indicator Tool Gp	1

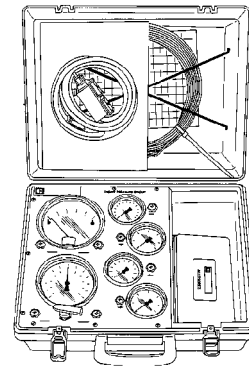

Illustration 58
1U-5470 Engine Pressure Test Group

g00293196

Refer to Special Instruction, SEHS8907, "Using the 1U-5470 Engine Pressure Test Group" for the instructions that are needed to use the 1U-5470 Engine Pressure Test Group. Refer to Operation Manual, NEHS0818, "Using the 198-4240 Pressure Indicator Tool Gp" for the instructions that are needed to use the 198-4240 Engine Indicator Test Gp.

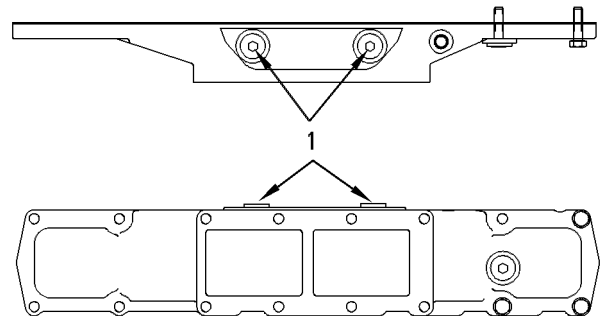

Illustration 59
Pressure Test Location
(1) Plug

g00295555

Use the following procedure in order to measure the inlet manifold pressure:

1. Remove plug (1) from the air inlet cover.
2. Connect the 1U-5470 Engine Pressure Test Group to the air inlet cover at the pressure test location.

Note: A tee fitting or some other plumbing component will be necessary to allow the boost pressure sensor to be connected with a test location.

3. Record the value.

4. Compare the value that was recorded in Step 3 to the pressure that is given in the TMI (Technical Marketing Information). The correct pressure is also given in the Fuel Setting And Related Information Microfiche.

i01281586

Exhaust Temperature - Test

SMCS Code: 1088-081

Table 10

Tools Needed		
Part Number	Part Name	Quantity
123-6700	Laser Infrared Thermometer	1

When the engine runs at low idle, the temperature of an exhaust manifold port can indicate the condition of a unit injector:

A low temperature indicates that no fuel is flowing to the cylinder. An inoperative unit injector pump could cause this low temperature.

A very high temperature can indicate that too much fuel is flowing to the cylinder. A malfunctioning unit injector could cause this very high temperature.

Use the 123-6700 Infrared Thermometer to check this exhaust temperature. You can find operating instructions and maintenance instructions inside the Operator's Manual, NEHS0630, "123-6700 Infrared Thermometer II with Laser Sighting".

i01665993

Aftercooler - Test

SMCS Code: 1063-081

Table 11

Required Tools		
Part Number	Part Name	Quantity
1U-5470 or 198-4240	Engine Pressure Group or Pressure Indicator Tool Gp	1
FT-1984	Aftercooler Testing Group	1
FT-1438	Aftercooler (Dynamometer Test)	1

Visual Inspection

Inspect the following parts at each oil change:

- Air lines

- Hoses
- Gasket joints

WARNING

Pressurized air can cause personal injury. When pressurized air is used for cleaning, wear a protective face shield, protective clothing, and protective shoes.

Ensure that the constant torque hose clamps are tightened to the correct torque. Check the truck manufacturer's specifications for the correct torque. Check the welded joints for cracks. Ensure that the brackets are tightened in the correct positions. Ensure that the brackets are in good condition. Use compressed air to clean any debris or any dust from the aftercooler core assembly. Inspect the cooler core fins for the following conditions:

- Damage
- Debris
- Corrosion

Use a stainless steel brush to remove any corrosion. Ensure that you use soap and water.

Note: When parts of the air-to-air aftercooler system are repaired, a leak test is recommended. When parts of the air-to-air aftercooler system are replaced, a leak test is recommended.

The use of winter fronts or shutters is discouraged with air-to-air aftercooled systems. Winter fronts can only be used on certain truck models. On these trucks, tests have shown that the engine jacket water will overheat before the inlet manifold air temperature is excessive. These trucks use sensors and indicators that are installed in order to indicate engine operating conditions before excessive inlet manifold air temperatures are reached. Check with the truck manufacturer about the use of both winter fronts and shutters.

Inlet Manifold Pressure

Normal inlet manifold pressure with high exhaust temperature can be caused by blockage of the fins of the aftercooler core. Clean the fins of the aftercooler core. Refer to "Visual Inspection" for the cleaning procedure.

Low inlet manifold pressure and high exhaust manifold temperature can be caused by any of the following conditions:

Plugged air cleaner – Clean the air cleaner or replace the air cleaner, as required. Refer to the Operation and Maintenance Manual, “Engine Air Cleaner Element - Clean/Replace”.

Blockage in the air lines – Blockage in the air lines between the air cleaner and the turbocharger must be removed.

Aftercooler core leakage – Aftercooler core leakage should be pressure tested. Refer to “Aftercooler Core Leakage” topic for the testing procedure.

Leakage of the induction system – Any leakage from the pressure side of the induction system should be repaired.

Inlet manifold leak – An inlet manifold leak can be caused by the following conditions: loose fittings and plugs, missing fittings and plugs, damaged fittings and plugs, and leaking inlet manifold gasket.

Aftercooler Core Leakage

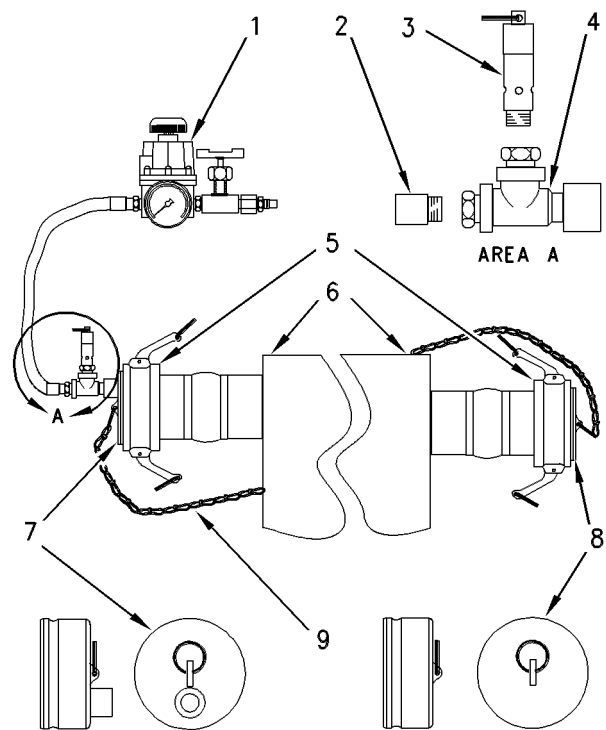

Illustration 60

g00295702

FT - 1984 Aftercooler Testing Group

- (1) Regulator and valve assembly
- (2) Nipple
- (3) Relief valve
- (4) Tee
- (5) Coupler
- (6) Aftercooler
- (7) Dust plug
- (8) Dust plug
- (9) Chain

A low power problem in the engine can be the result of aftercooler leakage. Aftercooler system leakage can result in the following problems:

- Low power
- Low boost pressure
- Black smoke
- High exhaust temperature

NOTICE

Remove all air leaks from the system to prevent engine damage. In some operating conditions, the engine can pull a manifold vacuum for short periods of time. A leak in the aftercooler or air lines can let dirt and other foreign material into the engine and cause rapid wear and/or damage to engine parts.

A large leak of the aftercooler core can often be found by making a visual inspection. To check for smaller leaks, use the following procedure:

1. Disconnect the air pipes from the inlet and outlet side of the aftercooler core.

WARNING

Dust plug chains must be installed to the aftercooler core or to the radiator brackets to prevent possible injury while you are testing. Do not stand in front of the dust plugs while you are testing.

2. Install couplers (5) on each side of the aftercooler core. Also, install dust plugs (7) and (8). These items are included with the FT-1984 Aftercooler Testing Group.

Note: Installation of additional hose clamps on the hump hoses is recommended in order to prevent the hoses from bulging while the aftercooler core is being pressurized.

NOTICE

Do not use more than 240 kPa (35 psi) of air pressure or damage to the aftercooler core can be the result.

3. Install the regulator and valve assembly (1) on the outlet side of the aftercooler core assembly. Also, attach the air supply.
4. Open the air valve and pressurize the aftercooler to 205 kPa (30 psi). Shut off the air supply.
5. Inspect all connection points for air leakage.
6. The aftercooler system's pressure should not drop more than 35 kPa (5 psi) in 15 seconds.
7. If the pressure drop is more than the specified amount, use a solution of soap and water to check all areas for leakage. Look for air bubbles that will identify possible leaks. Replace the aftercooler core, or repair the aftercooler core, as needed.

WARNING

To help prevent personal injury when the tooling is removed, relieve all pressure in the system slowly by using an air regulator and a valve assembly.

8. After the testing, remove the FT-1984 Aftercooler Testing Group. Reconnect the air pipes on both sides of the aftercooler core assembly.

Air System Restriction

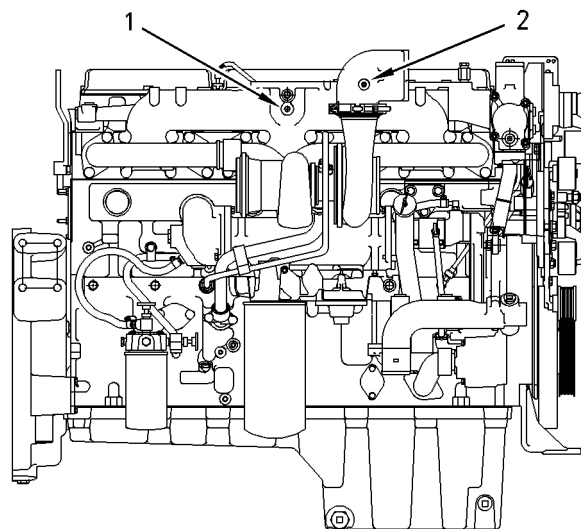

Illustration 61

g00581364

Pressure measurements should be taken at the inlet manifold (1) and at the turbocharger outlet (2).

Use the differential pressure gauge of the 1U-5470 Engine Pressure Group or use the 198-4240 Pressure Indicator Tool Gp. Use the following procedure in order to measure the restriction of the aftercooler:

1. Connect the vacuum port of the differential pressure gauge to port (1).
2. Connect the pressure port of the differential pressure gauge to port (2).
3. Record the value.

The air lines and the cooler core must be inspected for internal restriction when both of the following conditions are met:

- Air flow is at a maximum level.
- Total air pressure drop of the charged system exceeds 16.9 kPa (5 in Hg).

If a restriction is discovered, proceed with the following tasks, as required:

- Clean
- Repair
- Replacement

Turbocharger Failure

WARNING

Personal injury can result from air pressure.

Personal injury can result without following proper procedure. When using pressure air, wear a protective face shield and protective clothing.

Maximum air pressure at the nozzle must be less than 205 kPa (30 psi) for cleaning purposes.

If a turbocharger failure occurs, remove the air-to-air aftercooler core. Internally flush the air-to-air aftercooler core with a solvent that removes oil and other foreign substances. Shake the air-to-air aftercooler core in order to eliminate any trapped debris. Wash the aftercooler with hot, soapy water. Thoroughly rinse the aftercooler with clean water and blow dry the aftercooler with compressed air. Blow dry the assembly in the reverse direction of normal air flow. To make sure that the whole system is clean, carefully inspect the system.

NOTICE

Do not use caustic cleaners to clean the air-to-air aftercooler core.

Caustic cleaners will attack the internal metals of the core and cause leakage.

Dynamometer Test

In hot ambient temperatures, chassis dynamometer tests for models with an air-to-air aftercooler can add a greater heat load to the jacket water cooling system. Therefore, the jacket water cooling system's temperature must be monitored. The following measurements may also need a power correction factor:

- Inlet air temperature
- Fuel API rating
- Fuel temperature
- Barometric pressure

With dynamometer tests for engines, use the FT-1438 Aftercooler (Dynamometer Test). This tool provides a water cooled aftercooler in order to control the inlet air temperature to 43 °C (110 °F).

Engine Crankcase Pressure (Blowby) - Test

SMCS Code: 1215; 1317

Table 12

Tools Needed		
Part Number	Part Name	Quantity
8T-2700	Blowby/Air Flow Indicator	1

Damaged pistons or damaged rings can cause too much pressure in the crankcase. This condition will cause the engine to run rough. There will be more than the normal amount of fumes (blowby) rising from the crankcase breather. The breather can then become restricted in a very short time. This condition can cause oil leakage at gaskets and seals that would not normally have leakage. Blowby can also be caused by worn valve guides or by a failed turbocharger seal.

Note: The electronic service tool can be used to measure crankcase pressure.

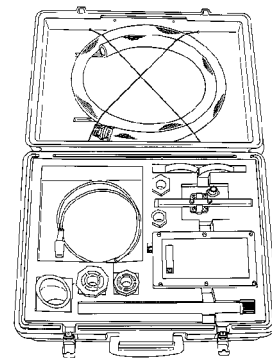

Illustration 62

g00286269

8T-2700 Blowby/Air Flow Indicator

The 8T-2700 Blowby/Air Flow Indicator is used to check the amount of blowby. Refer to Special Instruction, SEHS8712, "Using the 8T-2700 Blowby/Air Flow Indicator" for the test procedure for checking the blowby.

i01120286

Compression - Test

SMCS Code: 1215

An engine that runs roughly can have a leak at the valves. An engine that runs roughly can also have valves that need an adjustment. Remove the head and inspect the valves and valve seats. This is necessary to find those small defects that would not normally cause problems. Repairs of these problems are normally performed when you are reconditioning the engine.

i01849733

Engine Valve Lash - Inspect/Adjust

SMCS Code: 1102-025

! WARNING

To prevent possible injury, do not use the starter to turn the flywheel.

Hot engine components can cause burns. Allow additional time for the engine to cool before measuring valve clearance.

! WARNING

This engine uses high voltage to control the fuel injectors.

Disconnect electronic fuel injector enable circuit connector to prevent personal injury.

Do not come in contact with the fuel injector terminals while the engine is running.

Note: Valve lash is measured between the rocker arm and the bridge for the inlet valves. Valve lash is measured between the rocker arm and the valve stem for the exhaust valve. All of the clearance measurements and the adjustments must be made with the engine stopped. The valves must be FULLY CLOSED.

Valve Lash Check

An adjustment is NOT NECESSARY if the measurement of the valve lash is in the acceptable range. Adjust the valve lash while the engine is stopped. The range is specified in Table 13.

Table 13

	Inlet Valves	Exhaust Valves
Valve Lash Check (Stopped Engine)	0.38 ± 0.08 mm (0.0150 ± 0.0031 inch)	0.64 ± 0.08 mm (0.0252 ± 0.0031 inch)
TC Compression Stroke	1-2-4	1-3-5
TC Exhaust Stroke⁽¹⁾	3-5-6	2-4-6
Firing Order	1-5-3-6-2-4 ⁽²⁾	

(1) 360° from TC compression stroke

(2) The No. 1 cylinder is at the front of the engine.

If the measurement is not within this range adjustment is necessary. See Testing And Adjusting, "Valve Lash And Valve Bridge Adjustment".

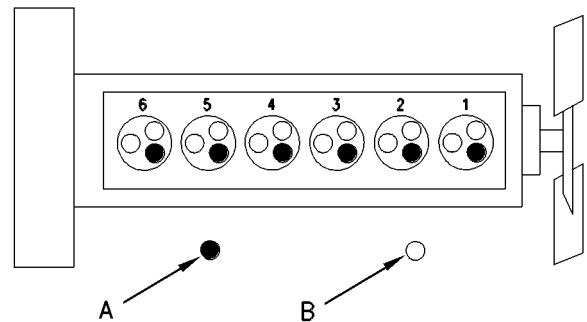

Illustration 63

g00290846

Cylinder and Valve Location

- (A) Exhaust valve
- (B) Inlet valves

Valve Lash and Valve Bridge Adjustment

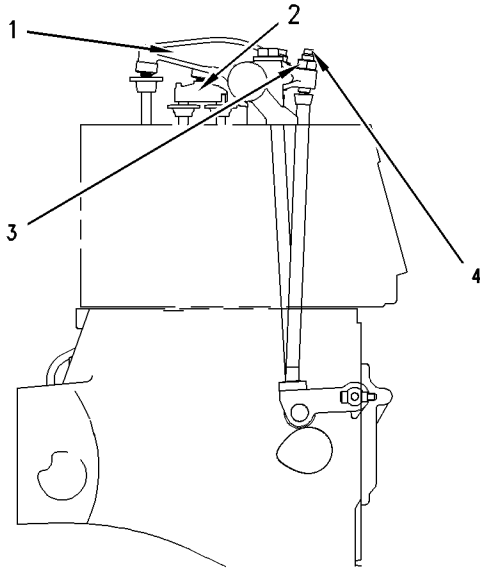

Illustration 64

g00942236

- (1) Exhaust rocker arm
- (2) Inlet valve bridge
- (3) Rocker arm adjustment screw locknut for the exhaust rocker arm
- (4) Rocker arm adjustment screw for the exhaust rocker arm

Table 14

Valve Lash	
Valves	Dimension of Gauge
Inlet	0.38 ± 0.08 mm (0.0150 ± 0.0031 inch)
Exhaust	0.64 ± 0.08 mm (0.0252 ± 0.0031 inch)

Adjust the valve lash while the engine is stopped. Use the following procedure to adjust the valves:

1. Put the No. 1 piston at the top center position on the compression stroke. Refer to Testing and Adjusting, "Finding Top Center Position for No. 1 Piston".

Table 15

TC Compression Stroke	Inlet Valves	Exhaust Valves
Valve Lash	0.38 ± 0.08 mm (0.0150 ± 0.0031 inch)	0.64 ± 0.08 mm (0.0252 ± 0.0031 inch)
Cylinders	1-2-4	1-3-5

2. Adjust the valve lash according to Table 15.

- a. Lightly tap the rocker arm at the top of the adjustment screw with a soft mallet. This will ensure that the lifter roller seats against the camshaft's base circle.
- b. Loosen the adjustment locknut.
- c. Place the appropriate feeler gauge between rocker arm and the valve bridge. Then, turn the adjustment screw in a clockwise direction. Slide the feeler gauge between the rocker arm and the valve bridge. Continue turning the adjustment screw until a slight drag is felt on the feeler gauge. Remove the feeler gauge.
- d. Tighten the adjustment locknut to a torque of 30 ± 7 N·m (22 ± 5 lb ft). Do not allow the adjustment screw to turn while you are tightening the adjustment locknut. Recheck the valve lash after tightening the adjustment locknut.

3. Remove the timing bolt and turn the flywheel by 360 degrees in the direction of engine rotation. This will put the No. 6 piston at the top center position on the compression stroke. Install the timing bolt in the flywheel.

Table 16

TC Exhaust Stroke ⁽³⁾	Inlet Valves	Exhaust Valves
Valve Lash	0.38 ± 0.08 mm (0.0150 ± 0.0031 inch)	0.64 ± 0.08 mm (0.0252 ± 0.0031 inch)
Cylinders	3-5-6	2-4-6

⁽³⁾ Position for No. 1 cylinder

4. Adjust the valve lash according to Table 16.

- a. Lightly tap the rocker arm at the top of the adjustment screw with a soft mallet. This will ensure that the lifter roller seats against the camshaft's base circle.
- b. Loosen the adjustment locknut.
- c. Place the appropriate feeler gauge between rocker arm and the valve bridge. Then, turn the adjustment screw in a clockwise direction. Slide the feeler gauge between the rocker arm and the valve bridge. Continue turning the adjustment screw until a slight drag is felt on the feeler gauge. Remove the feeler gauge.

- d.** Tighten the adjustment locknut to a torque of 30 ± 7 N·m (22.1268 ± 5 lb ft). Do not allow the adjustment screw to turn while you are tightening the adjustment locknut. Recheck the valve lash after tightening the adjustment locknut.
- 5.** Remove the timing bolt from the flywheel after all adjustments to the valve lash have been made. Reinstall the timing cover.

Lubrication System

i01565985

Engine Oil Pressure - Test

SMCS Code: 1304-081

Measuring Engine Oil Pressure

WARNING

Work carefully around an engine that is running. Engine parts that are hot, or parts that are moving, can cause personal injury.

NOTICE

Keep all parts clean from contaminants.

Contaminants may cause rapid wear and shortened component life.

NOTICE

Care must be taken to ensure that fluids are contained during performance of inspection, maintenance, testing, adjusting and repair of the product. Be prepared to collect the fluid with suitable containers before opening any compartment or disassembling any component containing fluids.

Refer to Special Publication, NENG2500, "Caterpillar Tools and Shop Products Guide" for tools and supplies suitable to collect and contain fluids on Caterpillar products.

Dispose of all fluids according to local regulations and mandates.

Table 17

Required Tools		
Part Number	Part Name	Quantity
1U-5470 or 198-4240	Engine Pressure Group or Digital Pressure Indicator	1
8J-7844	Adapter Fitting	1
3K-0360	O-Ring Seal	1
4M-5317 or 5P-2720	Terminal Bushing or Probe Adapter	1

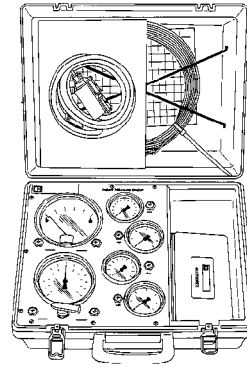

Illustration 65

g00296486

1U-5470 Engine Pressure Group

The 1U-5470 Engine Pressure Group measures the oil pressure in the system. This engine tool group can read the oil pressure inside the oil manifold.

Note: Refer to Special Instruction, SEHS8907, "Using the 1U-5470 Engine Pressure Group" for more information on using the 1U-5470 Engine Pressure Group.

Note: The engine oil pressure can also be measured by using an electronic service tool. Refer to Troubleshooting for information on the use of the electronic technician.

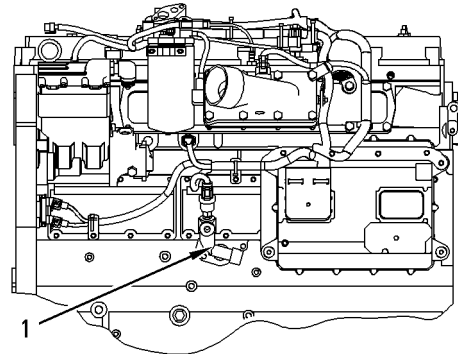

Illustration 66

g00864075

Oil Gallery Plug
(1) Plug.

1. Install the 1U-5470 Engine Pressure Group into oil gallery plug (1).

Note: Engine oil pressure to the camshaft and main bearings should be checked on each side of the cylinder block at oil gallery plug (1).

2. Start the engine. Run the engine with SAE 10W30 or SAE 15W40 oil. The information in the engine oil pressure graph is invalid for other oil viscosities. Refer to Operation and Maintenance Manual, "Engine Oil" for the recommendations of engine oil.

Note: Allow the engine to reach operating temperature before you perform the pressure test.

Note: The engine oil temperature should not exceed 115°C (239°F).

3. Record the value of the engine oil pressure when the engine has reached operating temperature.
4. Locate the point that intersects the lines for the engine rpm and for the oil pressure on the engine oil pressure graph.

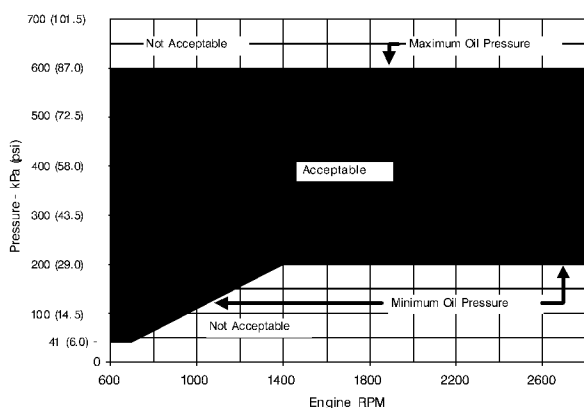

Illustration 67

g00866125

Engine Oil Pressure Graph

5. The results must fall within the "ACCEPTABLE" range on the chart. A problem exists when the results fall within the "NOT ACCEPTABLE" range on the chart. The problem needs to be corrected. Engine failure or a reduction in engine life can be the result if engine operation is continued with oil manifold pressure outside this range.

Note: A record of engine oil pressure can be used as an indication of possible engine problems or damage. A possible problem could exist if the oil pressure suddenly increases or decreases 70 kPa (10 psi) and the oil pressure is in the "ACCEPTABLE" range. The engine should be inspected and the problem should be corrected.

6. Compare the recorded engine oil pressure with the oil pressure indicators on the instrument panel and the engine oil pressure that is displayed on the electronic service tool.
7. An engine oil pressure indicator that has a defect or an engine oil pressure sensor that has a defect can give a false indication of a low oil pressure or a high oil pressure. If there is a notable difference between the engine oil pressure readings make necessary repairs.
8. If low engine oil pressure is determined, refer to "Reasons for Low Engine Oil Pressure".
9. If high engine oil pressure is determined, refer to "Reason for High Engine Oil Pressure".

Reasons for Low Engine Oil Pressure

NOTICE

Keep all parts clean from contaminants.

Contaminants may cause rapid wear and shortened component life.

NOTICE

Care must be taken to ensure that fluids are contained during performance of inspection, maintenance, testing, adjusting and repair of the product. Be prepared to collect the fluid with suitable containers before opening any compartment or disassembling any component containing fluids.

Refer to Special Publication, NENG2500, "Caterpillar Tools and Shop Products Guide" for tools and supplies suitable to collect and contain fluids on Caterpillar products.

Dispose of all fluids according to local regulations and mandates.

- Engine oil level is low. Refer to Step 1.
- Engine oil is contaminated. Refer to Step 2.
- The engine oil bypass valves are open. Refer to Step 3.
- The engine lubrication system is open. Refer to Step 4.
- The oil suction tube has a leak or a restricted inlet screen. Refer to Step 5.
- The engine oil pump is faulty. Refer to Step 6.
- Engine Bearings have excessive clearance. Refer to Step 7.

1. Check the engine oil level in the crankcase. The oil level can possibly be too far below the oil pump supply tube. This will cause the oil pump not to have the ability to supply enough lubrication to the engine components. If the engine oil level is low add engine oil in order to obtain the correct engine oil level. Refer to Operation and Maintenance Manual, "Engine Oil" for the recommendations of engine oil.
 2. Engine oil that is contaminated with fuel or coolant will cause low engine oil pressure. High engine oil level in the crankcase can be an indication of contamination. Determine the reason for contamination of the engine oil and make the necessary repairs. Replace the engine oil with the approved grade of engine oil. Also replace the engine oil filter. Refer to Operation and Maintenance Manual, "Engine Oil" for the recommendations of engine oil.
-
- NOTICE**
- Caterpillar oil filters are built to Caterpillar specifications. Use of an oil filter not recommended by Caterpillar could result in severe engine damage to the engine bearings, crankshaft, etc., as a result of the larger waste particles from unfiltered oil entering the engine lubricating system. Only use oil filters recommended by Caterpillar.
-
3. If the engine oil bypass valves are held in the open position, a reduction in the oil pressure can be the result. This may be due to debris in the engine oil. If the engine oil bypass valves are stuck in the open position, remove each engine oil bypass valve and clean each bypass valve in order to correct this problem. You must also clean each bypass valve bore. Install new engine oil filters. For information on the repair of the engine oil bypass valves, refer to Disassembly and Assembly, "Engine Oil Filter Base - Disassemble".
 4. An oil line or an oil passage that is open, broken, or disconnected will cause low engine oil pressure. An open lubrication system could be caused by a piston cooling jet that is missing or damaged.
- Note:** The piston cooling jets direct engine oil toward the bottom of the piston in order to cool the piston. This also provides lubrication for the piston pin. Breakage, a restriction, or incorrect installation of the piston cooling jets will cause seizure of the piston.
5. The inlet screen of the oil suction tube for the engine oil pump can have a restriction. This restriction will cause cavitation and a loss of engine oil pressure. Check the inlet screen on the oil pickup tube and remove any material that may be restricting engine oil flow. Low engine oil pressure may also be the result of the oil pickup tube that is drawing in air. Check the joints of the oil pickup tube for cracks or a damaged O-ring seal. Remove the engine oil pan in order to gain access to the oil pickup tube and the oil screen. Refer to Disassembly and Assembly, "Engine Oil Pan - Remove and Install" for more information.
 6. Check the following problems that may occur to the engine oil pump.
 - a. Air leakage in the supply side of the oil pump will also cause cavitation and loss of oil pressure. Check the supply side of the oil pump and make necessary repairs. For information on the repair of the engine oil pump, refer to Disassembly and Assembly, "Engine Oil Pump - Remove".
 - b. Oil pump gears that have too much wear will cause a reduction in oil pressure. Repair the engine oil pump. For information on the repair of the engine oil pump, refer to Disassembly and Assembly, "Engine Oil Pump - Remove".
 7. Excessive clearance at engine bearings will cause low engine oil pressure. Check the engine components that have excessive bearing clearance and make the necessary repairs.

Reason for High Engine Oil Pressure

NOTICE

Keep all parts clean from contaminants.

Contaminants may cause rapid wear and shortened component life.

NOTICE

Care must be taken to ensure that fluids are contained during performance of inspection, maintenance, testing, adjusting and repair of the product. Be prepared to collect the fluid with suitable containers before opening any compartment or disassembling any component containing fluids.

Refer to Special Publication, NENG2500, "Caterpillar Tools and Shop Products Guide" for tools and supplies suitable to collect and contain fluids on Caterpillar products.

Dispose of all fluids according to local regulations and mandates.

Engine oil pressure will be high if the engine oil bypass valves become stuck in the closed position and the engine oil flow is restricted. Foreign matter in the engine oil system could be the cause for the restriction of the oil flow and the movement of the engine oil bypass valves. If the engine oil bypass valves are stuck in the closed position, remove each bypass valve and clean each bypass valve in order to correct this problem. You must also clean each bypass valve bore. Install new engine oil filters. New engine oil filters will prevent more debris from causing this problem. For information on the repair of the engine oil filter bypass valve, refer to Disassembly and Assembly, "Engine Oil Filter Base - Disassemble".

NOTICE

Caterpillar oil filters are built to Caterpillar specifications. Use of an oil filter not recommended by Caterpillar could result in severe engine damage to the engine bearings, crankshaft, etc., as a result of the larger waste particles from unfiltered oil entering the engine lubricating system. Only use oil filters recommended by Caterpillar.

i01378651

Engine Oil Pump - Inspect

SMCS Code: 1304-040

If any part of the engine oil pump is worn enough in order to affect the performance of the engine oil pump, the engine oil pump must be replaced. Refer to the Specifications Module, "Engine Oil Pump" topic for clearances.

i01126690

Excessive Bearing Wear - Inspect

SMCS Code: 1203-040; 1211-040; 1219-040

When some components of the engine show bearing wear in a short time, the cause can be a restriction in an oil passage.

An engine oil pressure indicator may show that there is enough oil pressure, but a component is worn due to a lack of lubrication. In such a case, look at the passage for the oil supply to the component. A restriction in an oil supply passage will not allow enough lubrication to reach a component. This will result in early wear.

i01282970

Excessive Engine Oil Consumption - Inspect

SMCS Code: 1348-040

Oil Leakage On Outside Of Engine

Check for leakage at the seals at each end of the crankshaft. Look for leakage at the oil pan gasket and all lubrication system connections. Look for any oil that may be leaking from the crankcase breather. This can be caused by combustion gas leakage around the pistons. A dirty crankcase breather will cause high pressure in the crankcase. A dirty crankcase breather will cause the gaskets and the seals to leak.

Oil Leakage Into Combustion Area Of Cylinders

Oil leakage into the combustion area of the cylinders can be the cause of blue smoke. There are four possible ways for oil leakage into the combustion area of the cylinders:

- Oil leakage between worn valve guides and valve stems
- Worn components or damaged components (pistons, piston rings, or dirty oil return holes)
- Incorrect installation of the compression ring and/or the intermediate ring
- Oil leakage past the seal rings in the impeller end of the turbocharger shaft

Excessive oil consumption can also be the result if oil with the wrong viscosity is used. Oil with a thin viscosity can be caused by fuel leakage into the crankcase or by increased engine temperature.

i01283115

Increased Engine Oil Temperature - Inspect

SMCS Code: 1348-040

When the engine is at operating temperature and you are using SAE 10W30 oil, the maximum oil temperature is 115 °C (239 °F). This is the temperature of the oil after passing through the oil cooler.

Look for a restriction in the oil passages of the oil cooler. The oil temperature may be higher than normal when the engine is operating. In such a case, the oil cooler may have a restriction. A restriction in the oil cooler will not cause low oil pressure in the engine.

Determine if the oil cooler bypass valve is held in the open position. This condition will allow the oil to pass through the valve instead of the oil cooler. The oil temperature will increase.

Cooling System

i01389751

Cooling System - Check (Overheating)

SMCS Code: 1350-535

Above normal coolant temperatures can be caused by many conditions. Use the following procedure to determine the cause of above normal coolant temperatures:

WARNING

Personal injury can result from escaping fluid under pressure.

If a pressure indication is shown on the indicator, push the release valve in order to relieve pressure before removing any hose from the radiator.

1. Check the coolant level in the cooling system. Refer to Operation and Maintenance Manual, "Cooling System Coolant Level - Check". If the coolant level is too low, air will get into the cooling system. Air in the cooling system will cause a reduction in coolant flow and bubbles in the coolant. Air bubbles cause a reduction in the cooling of engine parts.
2. Check the quality of the coolant. The coolant should have the following properties:
 - Color that is similar to new coolant
 - Odor that is similar to new coolant
 - Free from dirt and debris

If the coolant does not have these properties, drain the system and flush the system. Refill the cooling system with the correct mixture of water, antifreeze, and coolant conditioner. Refer to Operation and Maintenance Manual, "General Coolant Information".

3. Check the coolant mixture of antifreeze and water. The mixture should be approximately 50 percent water and 50 percent antifreeze with 3 to 6 percent coolant conditioner. Refer to Operation and Maintenance Manual, "General Coolant Information". If the coolant mixture is incorrect, drain the cooling system and flush the cooling system. Refill the cooling system with the correct mixture of water, antifreeze, and coolant conditioner.

4. Check for air in the cooling system. Air can enter the cooling system in different ways. The following items are some of the most common causes for air in the cooling system:
 - Filling the cooling system incorrectly
 - Combustion gas leakage into the cooling system
 - Loose hose clamp

Combustion gas can get into the system through the following conditions: inside cracks, damaged cylinder head, and damaged cylinder head gasket. A loose hose clamp can allow air into the cooling system during the cooldown period. Air in the cooling system causes a reduction in the cooling capacity of the coolant.

5. Check the fan drive system. A fan drive system that is not turning at the correct speed can cause improper air speed across the radiator core. The lack of proper air flow across the radiator core can cause the coolant not to cool to the proper temperature differential.
6. Check the water temperature gauge. A water temperature gauge which does not work correctly will not show the correct temperature. Refer to Testing and Adjusting, "Cooling System - Test".
7. Check the sending unit. In some conditions, the temperature sensor in the engine sends signals to a sending unit. The sending unit converts these signals to an electrical impulse which is used by a mounted gauge. If the sending unit malfunctions, the gauge can show an incorrect reading. Also if the electric wire breaks or if the electric wire shorts out, the gauge can show an incorrect reading.
8. Check the radiator.
 - a. Check the radiator for a restriction to coolant flow. Check the radiator for debris, for dirt, or for deposits on the inside of the radiator core. Debris, dirt, or deposits will restrict the flow of coolant through the radiator.
 - b. Check for debris or for damage between the fins of the radiator core. Debris between the fins of the radiator core restricts air flow through the radiator core. Refer to Testing and Adjusting, "Cooling System - Inspect".
 - c. Check for missing radiator baffles or for damaged radiator baffles. Radiator baffles prevent recirculation of air around the sides of the radiator. A missing radiator baffle or a damaged radiator baffle raises the temperature of the air that goes through the radiator.

- d. Ensure that the radiator size is according to the OEM specifications. An undersized radiator does not have enough area for the effective release of heat. This may cause the engine to run at a temperature that is higher than normal. The normal temperature is dependent on the ambient temperature.
9. Check the filler cap. A pressure drop in the radiator can cause the boiling point to be lower. This can cause the cooling system to boil. Refer to Testing and Adjusting, "Cooling System - Test".
10. Check the fan and/or the fan shroud.
 - a. Ensure that the fan is installed correctly. Improper installation of the fan can cause engine overheating.
 - b. The fan must be large enough to send air through most of the area of the radiator core. Ensure that the size of the fan and the position of the fan are according to the OEM specifications.
 - c. The fan shroud and the radiator baffling must be the proper size. The fan shroud and the radiator baffling must be positioned correctly. The size of the fan shroud and the position of the fan shroud should meet the OEM specifications. The size of the radiator baffling and the position of the radiator baffling should meet the OEM specifications.
11. Check for loose drive belts.
 - a. A loose fan drive belt will cause a reduction in the air flow across the radiator. Check the fan drive belt for proper belt tension. Adjust the tension of the fan drive belt, if necessary. Refer to Operation and Maintenance Manual, "Belt - Inspect".
 - b. A loose water pump drive belt will cause a reduction in coolant flow through the radiator. Check the water pump drive belt for proper belt tension. Adjust the tension of the water pump drive belt, if necessary. Refer to Operation and Maintenance Manual, "Belt - Inspect".
12. Check the cooling system hoses and clamps. Damaged hoses with leaks can normally be seen. Hoses that have no visual leaks can soften during operation. The soft areas of the hose can become kinked or crushed during operation. These areas of the hose can cause a restriction in the coolant flow. Hoses can become soft. Also, hoses can get cracks after a period of time. The inside of a hose can deteriorate, and the loose particles of the hose can cause a restriction of the coolant flow. Refer to Operation and Maintenance Manual, "Hoses and Clamps - Inspect/Replace".
13. Check for a restriction in the air inlet system. A restriction of the air that is coming into the engine can cause high cylinder temperatures. High cylinder temperatures can cause higher than normal temperatures in the cooling system. Refer to Testing and Adjusting, "Air Inlet and Exhaust System - Inspect".
 - a. If the measured restriction is higher than the maximum permissible restriction, remove the foreign material from the engine air cleaner element or install a new engine air cleaner element. Refer to Operation and Maintenance Manual, "Engine Air Cleaner Element - Clean/Replace".
 - b. Check the air inlet system for a restriction again.
 - c. If the measured restriction is still higher than the maximum permissible restriction, check the air inlet piping for a restriction.
14. Check for a restriction in the exhaust system. A restriction of the air that is coming out of the engine can cause high cylinder temperatures.
 - a. Make a visual inspection of the exhaust system. Check for damage to exhaust piping. Also, check for a damaged muffler. If no damage is found, check the exhaust system for a restriction. Refer to Testing and Adjusting, "Air Inlet and Exhaust System - Inspect".
 - b. If the measured restriction is higher than the maximum permissible restriction, there is a restriction in the exhaust system. Repair the exhaust system, as required.
 - c. Ensure that the exhaust gas is not being drawn into the cooling air inlet.

i01390078

15. Check the shunt line. The shunt line must be submerged in the expansion tank. A restriction of the shunt line from the radiator top tank to the engine water pump inlet will cause a reduction in water pump efficiency. A reduction in water pump efficiency will result in low coolant flow and overheating.
16. Check the water temperature regulator. A water temperature regulator that does not open, or a water temperature regulator that only opens part of the way can cause overheating. Refer to Testing and Adjusting, "Water Temperature Regulator - Test".
17. Check the water pump. A water pump with a damaged impeller does not pump enough coolant for correct engine cooling. Remove the water pump and check for damage to the impeller. Refer to Testing and Adjusting, "Water Pump - Test".
18. Check the air flow through the engine compartment. The air flow through the radiator comes out of the engine compartment. Ensure that the filters, the air conditioner, and similar items are not installed in a way that prevents the free flow of air through the engine compartment.
19. Check the aftercooler. A restriction of air flow through the air to air aftercooler (if equipped) can cause overheating. Check for debris or deposits which would prevent the free flow of air through the aftercooler. Refer to Testing and Adjusting, "Aftercooler - Test".
20. Consider high outside temperatures. When outside temperatures are too high for the rating of the cooling system, there is not enough of a temperature difference between the outside air and coolant temperatures.
21. Consider high altitude operation. The cooling capacity of the cooling system goes down as the engine is operated at higher altitudes. A pressurized cooling system that is large enough to keep the coolant from boiling must be used.
22. The engine may be running in the lug condition. When the load that is applied to the engine is too large, the engine will run in the lug condition. When the engine is running in the lug condition, engine rpm does not increase with an increase of fuel. This lower engine rpm causes a reduction in air flow through the radiator. This lower engine rpm also causes a reduction in coolant flow through the system. This combination of less air and less coolant flow during high input of fuel will cause above normal heating.

Cooling System - Inspect

SMCS Code: 1350-040

Cooling systems that are not regularly inspected are the cause for increased engine temperatures. Make a visual inspection of the cooling system before any tests are performed.

WARNING

Personal injury can result from escaping fluid under pressure.

If a pressure indication is shown on the indicator, push the release valve in order to relieve pressure before removing any hose from the radiator.

1. Check the coolant level in the cooling system. Refer to Operation and Maintenance Manual, "Cooling System Coolant Level - Check".
2. Check the quality of the coolant. The coolant should have the following properties:
 - Color that is similar to new coolant
 - Odor that is similar to new coolant
 - Free from dirt and debris

If the coolant does not have these properties, drain the system and flush the system. Refill the cooling system with the correct mixture of water, antifreeze, and coolant conditioner. Refer to Operation and Maintenance Manual, "General Coolant Information".
3. Look for leaks in the system.

Note: A small amount of coolant leakage across the surface of the water pump seals is normal. This leakage is required in order to provide lubrication for this type of seal. A hole is provided in the water pump housing in order to allow this coolant/seal lubricant to drain from the pump housing. Intermittent leakage of small amounts of coolant from this hole is not an indication of water pump seal failure.
4. Ensure that the airflow through the radiator does not have a restriction. Look for bent core fins between the folded cores of the radiator. Also, look for debris between the folded cores of the radiator.
5. Inspect the drive belts for the fan.
6. Check for damage to the fan blades.

7. Look for air or combustion gas in the cooling system.
8. Inspect the filler cap, and check the surface that seals the filler cap. This surface must be clean.

i01849241

Cooling System - Test

SMCS Code: 1350-040; 1350-081

This engine has a pressure type cooling system. A pressure type cooling system has two advantages. The cooling system can be operated in a safe manner at a temperature higher than the normal boiling point (steam) of water.

This type of system prevents cavitation in the water pump. Cavitation is the forming of low pressure bubbles in liquids that are caused by mechanical forces. The formation of an air pocket or a steam pocket in this type of cooling system is difficult.

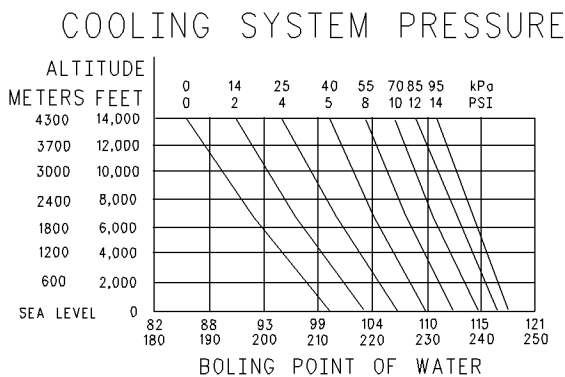

Illustration 68

g00921815

Boiling point of water

Remember that temperature and pressure work together. When a diagnosis is made of a cooling system problem, temperature and pressure must be checked. Cooling system pressure will have an effect on the cooling system temperature. For an example, refer to Illustration 68. This will show the effect of pressure on the boiling point (steam) of water. This will also show the effect of height above sea level.

WARNING

Personal injury can result from hot coolant, steam and alkali.

At operating temperature, engine coolant is hot and under pressure. The radiator and all lines to heaters or the engine contain hot coolant or steam. Any contact can cause severe burns.

Remove filler cap slowly to relieve pressure only when engine is stopped and radiator cap is cool enough to touch with your bare hand.

Cooling System Conditioner contains alkali. Avoid contact with skin and eyes.

The coolant level must be to the correct level in order to check the coolant system. The engine must be cold and the engine must not be running.

After the engine is cool, loosen the pressure cap in order to relieve the pressure out of the cooling system. Then remove the pressure cap.

The level of the coolant should not be more than 13 mm (0.5 inch) from the bottom of the filler pipe. If the cooling system is equipped with a sight glass, the coolant should be to the proper level in the sight glass.

Test Tools For Cooling System

Table 18

Tools Needed		
Part Number	Part Name	Quantity
4C-6500	Digital Thermometer	1
8T-2700	Blowby/Air Flow Indicator	1
9S-8140	Pressurizing Pump	1
9U-7400 or 1U-6602	Multitach Tool Group or Photo-Tachometer	1
1U-7297	Coolant/Battery Tester	1
1U-7298	Coolant/Battery Tester	1

WARNING

Making contact with a running engine can cause burns from hot parts and can cause injury from rotating parts.

When working on an engine that is running, avoid contact with hot parts and rotating parts.

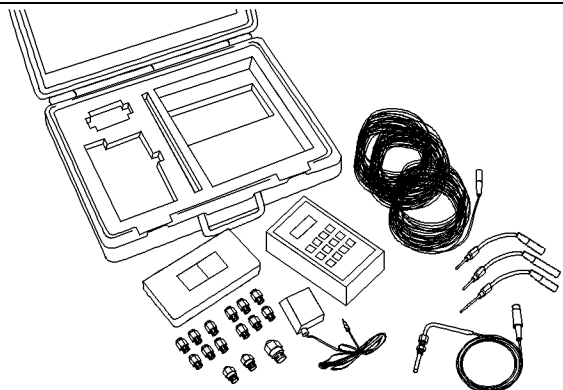

Illustration 69 g00876179
4C-6500 Digital Thermometer

The **4C-6500** Digital Thermometer is used in the diagnosis of overheating conditions and in the diagnosis of overcooling conditions. This group can be used to check temperatures in several different parts of the cooling system. Refer to Operating Manual, NEHS0554, “**4C-6500** Digital Thermometer Group” for the testing procedure.

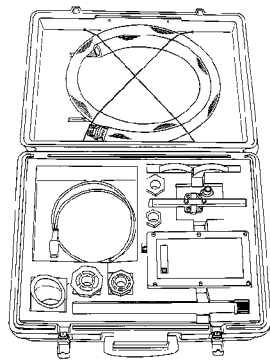

Illustration 70 g00286269
8T-2700 Blowby/Air Flow Indicator

The **8T-2700** Blowby/Air Flow Indicator is used to check the air flow through the radiator core. Refer to Special Instruction, SEHS8712, “Using the **8T-2700** Blowby/Air Flow Indicator” for the test procedure for checking blowby.

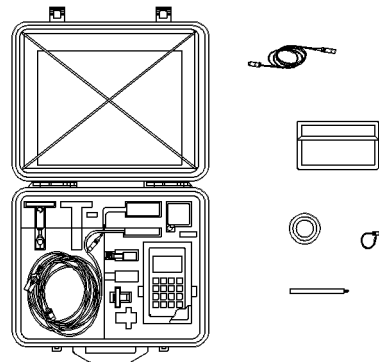

Illustration 71 g00286276
9U-7400 Multitach Tool Group

The **9U-7400** Multitach Tool Group is used to check the fan speed. Refer to Operating Manual, NEHS0605, “**9U-7400** Multitach Tool Group ” for the testing procedure.

The **9U-7400** Multitach Tool Group can measure engine rpm from a magnetic pickup. This magnetic pickup is located in the flywheel housing. The magnetic pickup also uses the ability to measure engine rpm from visual engine parts that are rotating.

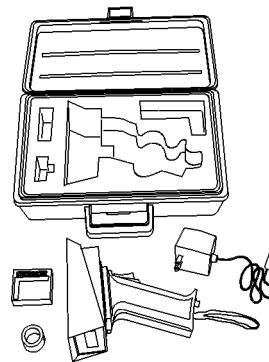

Illustration 72 g00296064
1U-6602 Photo-Tachometer

The **1U-6602** Photo-Tachometer is a photo-tachometer that is held by hand for general use. The **1U-6602** Photo-Tachometer is a phototach, so this tachometer only registers basic input frequency on any visible, rotating part. The basic input frequency equals one revolution per a piece of reflective tape. The **1U-6602** Photo-Tachometer does not replace the **9U-7400** Multitach Tool Group.

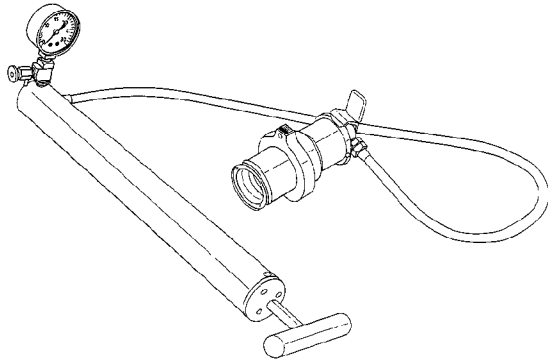

Illustration 73 g00286369
9S-8140 Pressurizing Pump

The 9S-8140 Pressurizing Pump is used to test the filler caps. This pressurizing pump is also used to pressure test the cooling system for leaks.

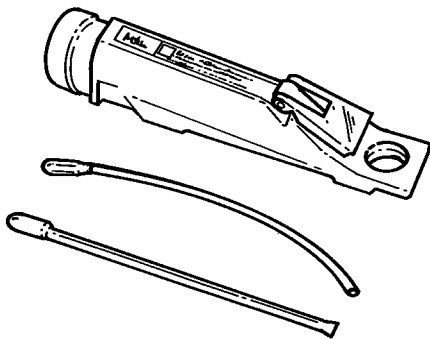

Illustration 74 g00439083
1U-7297 Coolant/Battery Tester or 1U-7298 Coolant/Battery Tester

Check the coolant frequently in cold weather for the proper glycol concentration. Use either the 1U-7297 Coolant/Battery Tester or the 1U-7298 Coolant/Battery Tester in order to ensure adequate freeze protection. The testers are identical except for the temperature scale. The testers give immediate, accurate readings. The testers can be used for antifreeze/coolants that contain ethylene or propylene glycol.

Making the Correct Antifreeze Mixtures

Adding pure antifreeze as a makeup solution for the cooling system top-off is an unacceptable practice. Adding pure antifreeze increases the concentration of antifreeze in the cooling system. This increases the concentration of the dissolved solids and the undissolved chemical inhibitors in the cooling system. Add the antifreeze and water mixture to the same freeze protection as your cooling system. The following chart assists in determining the concentration of antifreeze to use. Refer to Operation and Maintenance Manual, "General Coolant Information".

Table 19

Antifreeze Concentrations	
Temperature	Concentration
Protection to -15 °C (5 °F)	30% antifreeze and 70% water
Protection to -23 °C (-10 °F)	40% antifreeze and 60% water
Protection to -37 °C (-34 °F)	50% antifreeze and 50% water
Protection to -51 °C (-60 °F)	60% antifreeze and 40% water

Checking the Filler Cap

Table 20

Tools Needed		
Part Number	Part Name	Quantity
9S-8140	Pressurizing Pump	1

One cause for a pressure loss in the cooling system can be a damaged seal on the radiator filler cap.

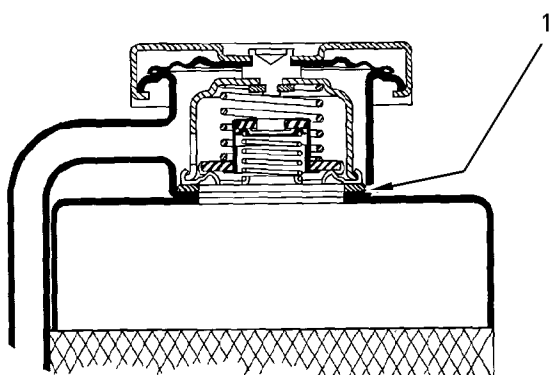

Illustration 75

g00296067

Typical schematic of filler cap

(1) Sealing surface of both filler cap and radiator

⚠ WARNING

Personal injury can result from hot coolant, steam and alkali.

At operating temperature, engine coolant is hot and under pressure. The radiator and all lines to heaters or the engine contain hot coolant or steam. Any contact can cause severe burns.

Remove filler cap slowly to relieve pressure only when engine is stopped and radiator cap is cool enough to touch with your bare hand.

Cooling System Conditioner contains alkali. Avoid contact with skin and eyes.

To check for the amount of pressure that opens the filler cap, use the following procedure:

1. After the engine cools, carefully loosen the filler cap. Slowly release the pressure from the cooling system. Then, remove the filler cap.

Carefully inspect the filler cap. Look for any damage to the seals and to the sealing surface. Inspect the following components for any foreign substances:

- Filler cap
- Seal
- Surface for seal

Remove any deposits that are found on these items, and remove any material that is found on these items.

2. Install the filler cap on the **9S-8140** Pressurizing Pump.

3. Look at the gauge for the exact pressure that opens the filler cap.
4. Compare the gauge's reading with the opening pressure that is listed on the filler cap.
5. If the filler cap is damaged, replace the filler cap.

Testing The Radiator And Cooling System For Leaks

Table 21

Tools Needed		
Part Number	Part Name	Quantity
9S-8140	Pressurizing Pump	1

Use the following procedure in order to check the cooling system for leaks:

⚠ WARNING

Personal injury can result from hot coolant, steam and alkali.

At operating temperature, engine coolant is hot and under pressure. The radiator and all lines to heaters or the engine contain hot coolant or steam. Any contact can cause severe burns.

Remove filler cap slowly to relieve pressure only when engine is stopped and radiator cap is cool enough to touch with your bare hand.

Cooling System Conditioner contains alkali. Avoid contact with skin and eyes.

1. After the engine is cool, loosen the filler cap slowly and allow pressure out of the cooling system. Then remove the filler cap from the radiator.
2. Ensure that the coolant level is above the top of the radiator core.
3. Install the **9S-8140** Pressurizing Pump onto the radiator.
4. Take the pressure reading on the gauge to 20 kPa (3 psi) more than the pressure on the filler cap.
5. Check the radiator for leakage on the outside.
6. Check all connection points for leakage, and check the hoses for leakage.

The cooling system does not have leakage only if the following conditions exist:

- You do NOT observe any outside leakage.
- The reading remains steady after five minutes.

The inside of the cooling system has leakage only if the following conditions exist:

- The reading on the gauge goes down.
- You do NOT observe any outside leakage.

Make any repairs, as required.

Test For The Water Temperature Gauge

Table 22

Tools Needed		
Part Number	Part Name	Quantity
4C-6500 or 2F-7112	Digital Thermometer or Thermometer	1

WARNING

Personal injury can result from escaping fluid under pressure.

If a pressure indication is shown on the indicator, push the release valve in order to relieve pressure before removing any hose from the radiator.

WARNING

Making contact with a running engine can cause burns from hot parts and can cause injury from rotating parts.

When working on an engine that is running, avoid contact with hot parts and rotating parts.

Check the accuracy of the water temperature indicator or water temperature sensor if you find either of the following conditions:

- The engine runs at a temperature that is too hot, but a normal temperature is indicated. A loss of coolant is found.
- The engine runs at a normal temperature, but a hot temperature is indicated. No loss of coolant is found.

Coolant temperature can also be read on the display screens of the Electronic Service Tool (ET or ECAP).

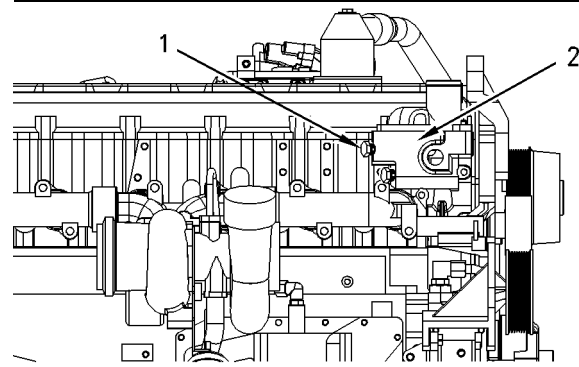

Illustration 76

g00296551

Test Location

- (1) Plug
- (2) Water temperature regulator housing

Remove the plug from one of ports (1). Install one of the following thermometers in the open port:

- The 4C-6500 Digital Thermometer
- The 2F-7112 Thermometer

A temperature indicator of known accuracy can also be used to make this check.

Start the engine. Run the engine until the temperature reaches the desired range according to the test thermometer. If necessary, place a cover over part of the radiator in order to cause a restriction of the air flow. The reading on the water temperature indicator should agree with the test thermometer within the tolerance range of the water temperature indicator.

i01666401

Water Temperature Regulator - Test

SMCS Code: 1355-081; 1355-081-ON

WARNING

Personal injury can result from escaping fluid under pressure.

If a pressure indication is shown on the indicator, push the release valve in order to relieve pressure before removing any hose from the radiator.

1. Remove the water temperature regulator from the engine.

2. Heat water in a pan until the temperature of the water is equal to the fully open temperature of the water temperature regulator. Refer to Specifications, "Water Temperature Regulator" for the fully open temperature of the water temperature regulator. Stir the water in the pan. This will distribute the temperature throughout the pan.
3. Hang the water temperature regulator in the pan of water. The water temperature regulator must be below the surface of the water. The water temperature regulator must be away from the sides and the bottom of the pan.
4. Keep the water at the correct temperature for ten minutes.
5. After ten minutes, remove the water temperature regulator. Immediately measure the opening of the water temperature regulator. Refer to Specifications, "Water Temperature Regulator" for the minimum opening distance of the water temperature regulator at the fully open temperature.

If the distance is less than the amount listed in the manual, replace the water temperature regulator.

i01849228

Water Pump - Test

SMCS Code: 1361-081

Table 23

Required Tools		
Part Number	Part Name	Quantity
6V - 7775	Air Pressure Gauge	1
8J - 7844	Adapter Fitting	1
3K - 0360	O-Ring Seal	1
5P - 2725	Probe Seal Adapter	1
164 - 2192	Pressure Probe ⁽¹⁾	1
5P - 4487	Adapter	1
5P - 2720	Probe Adapter	1

⁽¹⁾ If port (1) is used, two tools are required.

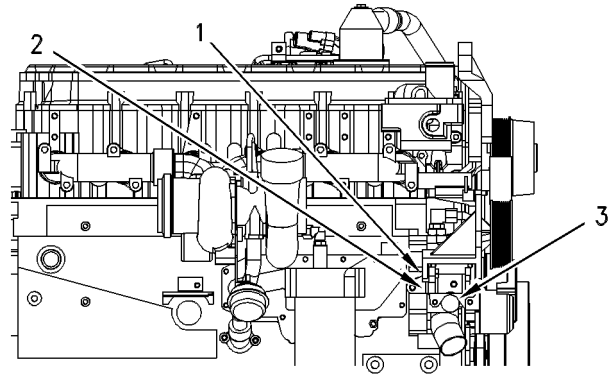

Illustration 77

g00296313

Pressure test ports for the water pump (Typical example)

- (1) Port (alternate heater supply)
- (2) Port (engine diagnosis)
- (3) Port (heater return line)

⚠ WARNING

Making contact with a running engine can cause burns from hot parts and can cause injury from rotating parts.

When working on an engine that is running, avoid contact with hot parts and rotating parts.

The pressure rise is the difference between inlet pressure and outlet pressure. The pressure rise indicates if the water pump operates correctly. Port (1) and Port (2) represent the water pump outlet pressure. Port (3) represents the water pump inlet pressure.

To measure the pressure rise, compare inlet pressure with outlet pressure. Calculate the difference between the pressure of the inlet port and the outlet ports. The pressure rise must add up to a minimum of 80 kPa (12 psi) under both of the following conditions:

- The engine is at operating temperature.
- The engine operates at full load condition.

Basic Engine

i01432013

Piston Ring Groove - Inspect

SMCS Code: 1214-040

The 186-0190 Piston Ring Groove Gauge Gp is available to check the top ring groove in the piston. Refer to the instruction card with the tool for the correct use of the 186-0190 Piston Ring Groove Gauge Gp.

i01284815

Connecting Rod Bearings - Inspect

SMCS Code: 1219-040

The connecting rod bearings fit tightly in the bore in the rod. If the bearing joints are fretted, check the bore size. This can be an indication of wear because of a loose fit.

Connecting rod bearings are available with 0.25 mm (0.010 inch) and 0.50 mm (0.020 inch) smaller inside diameter than the original size bearings. These bearings are for crankshafts that have been ground.

i01284843

Main Bearings - Inspect

SMCS Code: 1203-040

Main bearings are available with 0.25 mm (0.010 inch) and a 0.50 mm (0.020 inch) smaller inside diameter than the original size bearings. These bearings are for crankshafts that have been ground.

Main bearings are also available with a larger outside diameter than the original size bearings. These bearings are used for the cylinder blocks with the main bearing bore that is made larger than the bore's original size. The size that is available has a 0.50 mm (0.020 inch) outside diameter that is larger than the original size bearings.

Refer to Special Instruction, SMHS7606, "Use of 1P-4000 Line Boring Tool Group" for the instructions that are needed to use the 1P-4000 Line Boring Tool Group. The 1P-4000 Line Boring Tool Group is used in order to check the alignment of the main bearing bores. The 1P-3537 Dial Bore Gauge Group can be used to check the size of the bore. Refer to Special Instruction, GMG00981, "1P-3537 Dial Bore Gauge Group" for the instructions that are needed to use the 1P-3537 Dial Bore Gauge Group.

i01854009

Cylinder Block - Inspect

SMCS Code: 1201-040

Table 24

Required Tools		
Part Number	Part Name	Quantity
1P-3537	Dial Bore Gauge Group	1

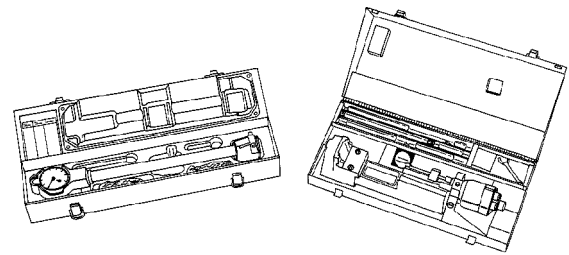

Illustration 78

g00285686

1P-3537 Dial Bore Gauge Group

If the main bearing caps are installed without bearings, the bore in the block for the main bearings can be checked. Tighten the nuts on the bearing caps to the torque that is given in Specifications, "Cylinder Block". Alignment error in the bores must not be more than 0.08 mm (0.003 inch).

The 1P-3537 Dial Bore Gauge Group can be used to check the size of the bore. Refer to Special Instruction, GMG00981, "1P-3537 Dial Bore Gauge Group" for the instructions that are needed to use the 1P-3537 Dial Bore Gauge Group.

i01284996

Flywheel - Inspect

SMCS Code: 1156-040

Table 25

Tools Needed		
Part Number	Part Name	Quantity
8T-5096	Dial Indicator	1

Face Runout (axial eccentricity) of the Flywheel

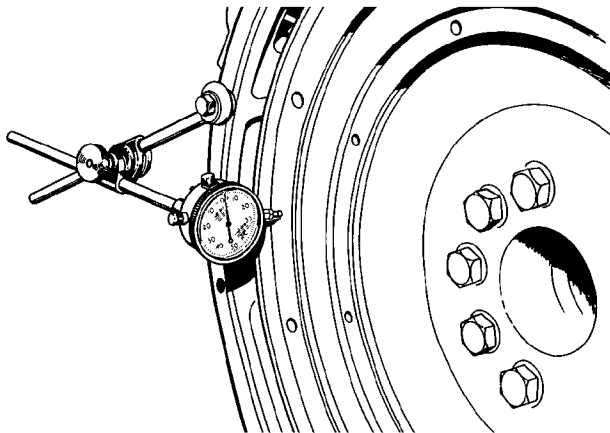

Illustration 79

g00286049

Checking face runout of the flywheel

1. Refer to Illustration 79 and install the dial indicator. Always put a force on the crankshaft in the same direction before the dial indicator is read. This will remove any crankshaft end clearance.
2. Set the dial indicator to read 0.0 mm (0.00 inch).
3. Turn the flywheel at intervals of 90 degrees and read the dial indicator.
4. Take the measurements at all four points. The difference between the lower measurements and the higher measurements that are performed at all four points must not be more than 0.15 mm (0.006 inch), which is the maximum permissible face runout (axial eccentricity) of the flywheel.

Bore Runout (radial eccentricity) of the Flywheel

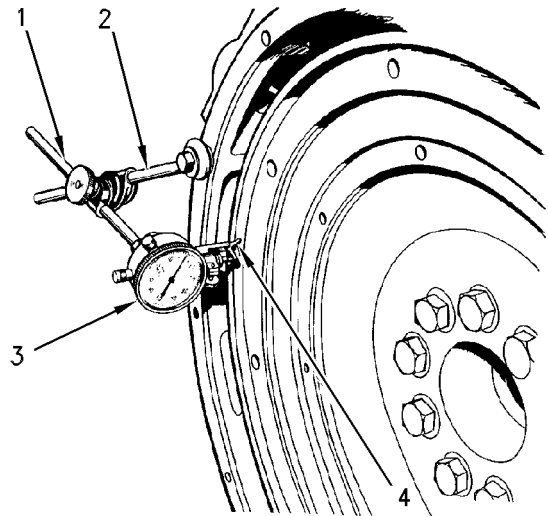

Illustration 80

g00286054

Checking bore runout of the flywheel

- (1) 7H-1945 Holding Rod
- (2) 7H-1645 Holding Rod
- (3) 7H-1942 Dial Indicator
- (4) 7H-1940 Universal Attachment

1. Install 7H-1942 Dial Indicator (3). Make an adjustment of 7H-1940 Universal Attachment (4) so the dial indicator makes contact on the flywheel.
2. Set the dial indicator to read 0.0 mm (0.00 inch).
3. Turn the flywheel at intervals of 90 degrees and read the dial indicator.
4. Take the measurements at all four points. The difference between the lower measurements and the higher measurements that are performed at all four points must not be more than 0.15 mm (0.006 inch), which is the maximum permissible face runout (radial eccentricity) of the flywheel.

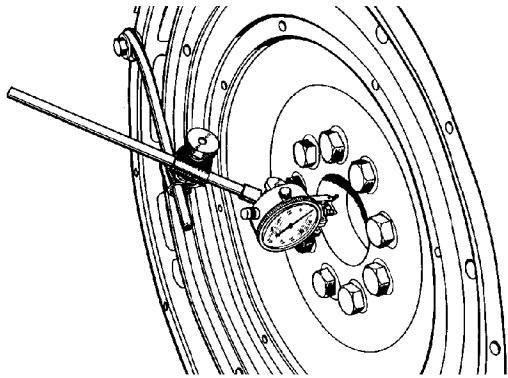

Illustration 81
Flywheel clutch pilot bearing bore

5. To find the runout (eccentricity) of the pilot bearing bore, use the preceding procedure.
6. The runout (eccentricity) of the bore for the pilot bearing in the flywheel must not exceed 0.13 mm (0.005 inch).

i01340595

Flywheel Housing - Inspect

SMCS Code: 1157-040

Table 26

Tools Needed		
Part Number	Part Name	Quantity
8T-5096	Dial Indicator	1

Face Runout (Axial Eccentricity) of the Flywheel Housing

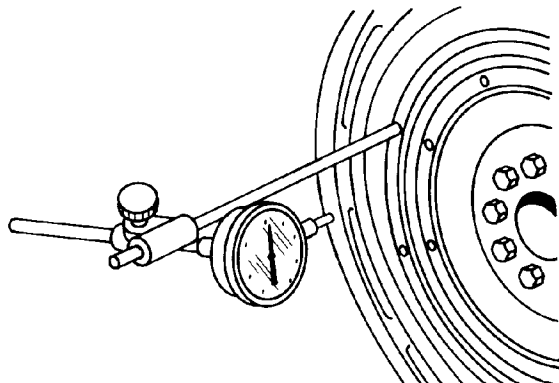

Illustration 82
8T-5096 Dial Indicator

If you use any other method except the method that is given here, always remember that the bearing clearance must be removed in order to receive the correct measurements.

1. Fasten a dial indicator to the flywheel so the anvil of the dial indicator will contact the face of the flywheel housing.
2. Put a force on the crankshaft toward the rear before the dial indicator is read at each point.

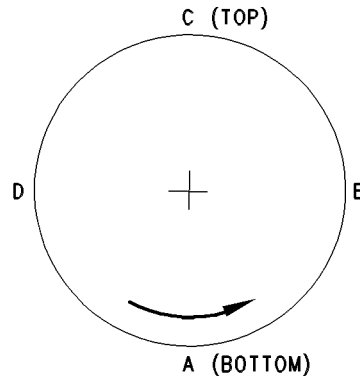

Illustration 83
Checking face runout of the flywheel housing

3. Turn the flywheel while the dial indicator is set at 0.0 mm (0.00 inch) at location (A). Read the dial indicator at locations (B), (C) and (D).
4. The difference between the lower measurements and the higher measurements that are performed at all four points must not be more than 0.30 mm (0.012 inch), which is the maximum permissible face runout (axial eccentricity) of the flywheel housing.

Bore Runout (Radial Eccentricity) of the Flywheel Housing

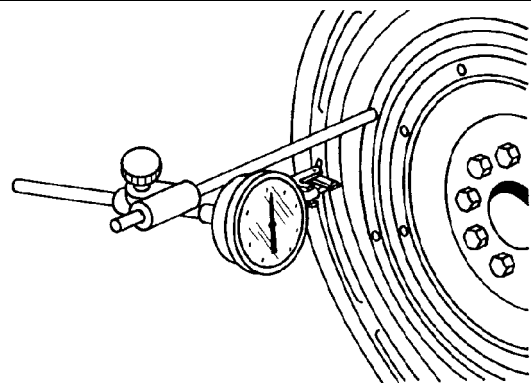

Illustration 84
8T-5096 Dial Indicator

1. Fasten a dial indicator to the flywheel so the anvil of the dial indicator will contact the bore of the flywheel housing.

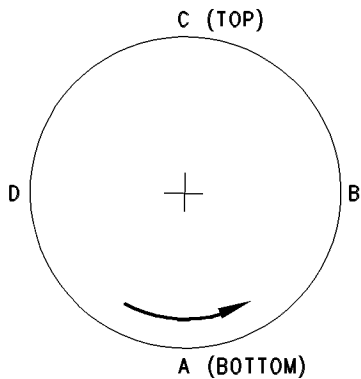

Illustration 85 g00285932
Checking bore runout of the flywheel housing

CHART FOR DIAL INDICATOR MEASUREMENTS					
	Position of dial indicator				
	Line No.	A	B	C	D
Correction for bearing clearance	I	0			
Dial Indicator Reading	II	0			
Total of Line 1 & 2	III	0	**	*	**
*Total Vertical eccentricity (out of round). **Subtract the smaller No. from the larger No. The difference is the total horizontal eccentricity.					

Illustration 86 g00285936

2. While the dial indicator is in the position at location (C) adjust the dial indicator to 0.0 mm (0.00 inch). Push the crankshaft upward against the top of the bearing. Refer to Illustration 86. Write the measurement for bearing clearance on line 1 in column (C).

Note: Write the measurements for the dial indicator with the correct notations. This notation is necessary for making the calculations in the chart correctly.

3. Divide the measurement from Step 2 by two. Write this number on line 1 in columns (B) and (D).
4. Turn the flywheel in order to put the dial indicator at position (A). Adjust the dial indicator to 0.0 mm (0.00 inch).
5. Turn the flywheel counterclockwise in order to put the dial indicator at position (B). Write the measurements in the chart.
6. Turn the flywheel counterclockwise in order to put the dial indicator at position (C). Write the measurement in the chart.

7. Turn the flywheel counterclockwise in order to put the dial indicator at position (D). Write the measurement in the chart.
8. Add the lines together in each column.
9. Subtract the smaller number from the larger number in column B and column D. Place this number on line III. The result is the horizontal eccentricity (out of round). Line III in column C is the vertical eccentricity.

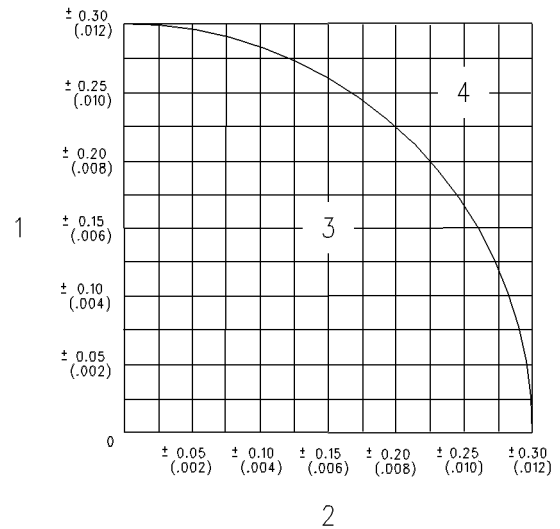

Illustration 87 g00286046

Graph for total eccentricity

- (1) Total vertical eccentricity
 - (2) Total horizontal eccentricity
 - (3) Acceptable value
 - (4) Unacceptable value
10. Find the intersection of the eccentricity lines (vertical and horizontal) in Illustration 87.
 11. If the point of the intersection is in the ACCEPTABLE range, the bore is in alignment. If the point of intersection is in the NOT ACCEPTABLE range, the flywheel housing must be changed.

i01854720

Vibration Damper - Check

SMCS Code: 1205-535

Rubber Vibration Damper

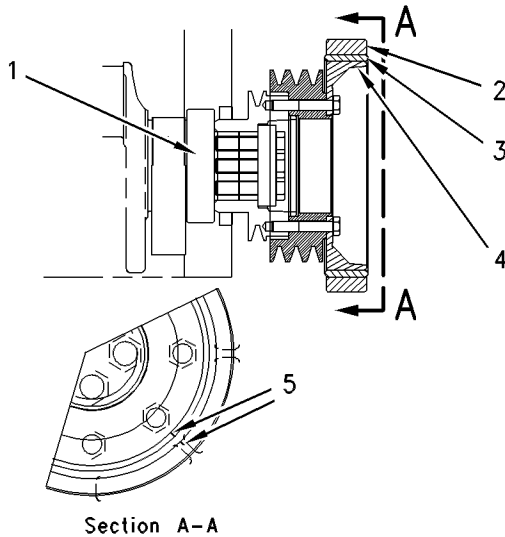

Illustration 88

g00295949

Rubber vibration damper

- (1) Crankshaft
- (2) Hub
- (3) Rubber
- (4) Ring
- (5) Alignment marks

Damage to the vibration damper or failure of the vibration damper will increase vibrations. This will result in damage to the crankshaft.

If any of the following problems with the rubber vibration damper exist, replace the rubber vibration damper:

- Damaged
- Bent
- Worn bolt holes with loose fit for bolts
- Crankshaft failure due to torsional forces

The rubber vibration damper displays alignment marks on the hub and on the ring. These marks indicate the condition of the rubber vibration damper.

If the alignment marks are not aligned, the rubber portion of the rubber vibration damper has separated from the hub and/or from the ring. When the alignment marks are not aligned, replace the rubber vibration damper.

A used rubber vibration damper can have a visual wobble of the outer ring. When the vibration damper rotates, this wobble consists of movement from the front to the rear. This does not call for a replacement, because some wobble of the outer ring is typical. Use the following procedure to make sure that the wobble of the outer ring is acceptable:

1. Install a dial indicator, a contact point, or other parts that are required to hold the dial indication stationary.

Note: The contact point must be perpendicular (90 degree angle) to the face of the outer ring of the rubber vibration damper. The contact point must make contact near to the center of the outer ring.

2. Push on the front end of the crankshaft in order to prevent any end play. End play would be free movement on the centerline. You must keep pressure on the crankshaft, until you complete the measurements.
3. Set the dial indicator to a reading of 0.0 mm (0.00 inch).
4. Turn the crankshaft by 360 degrees and watch the dial indicator. A total indicator reading of 0.00 to 2.03 mm (0.000 to 0.080 inch) is acceptable.

Electrical System

i01665449

Battery - Test

SMCS Code: 1401-081

Most of the tests of the electrical system can be done on the engine. The wiring insulation must be in good condition. The wire and cable connections must be clean, and both components must be tight.

WARNING

Never disconnect any charging unit circuit or battery circuit cable from the battery when the charging unit is operated. A spark can cause an explosion from the flammable vapor mixture of hydrogen and oxygen that is released from the electrolyte through the battery outlets. Injury to personnel can be the result.

The battery circuit is an electrical load on the charging unit. The load is variable because of the condition of the charge in the battery.

NOTICE

The charging unit will be damaged if the connections between the battery and the charging unit are broken while the battery is being charged. Damage occurs because the load from the battery is lost and because there is an increase in charging voltage. High voltage will damage the charging unit, the regulator, and other electrical components.

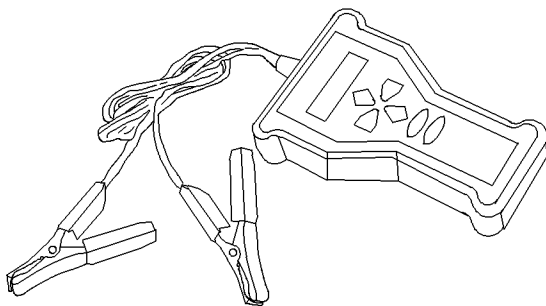

Illustration 89

177-2330 Battery Analyzer

g00859857

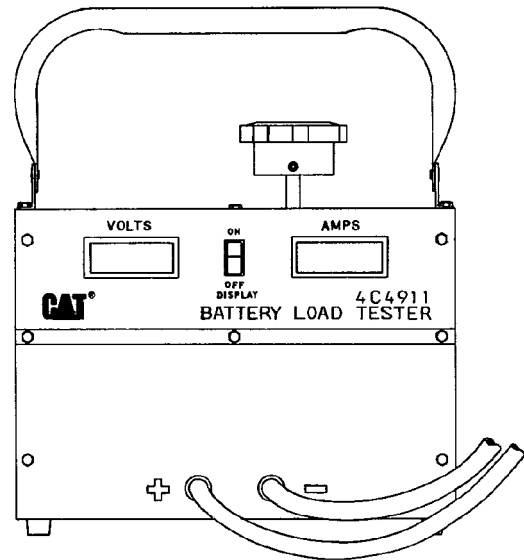

Illustration 90

4C-4911 Battery Load Tester

g00283565

Use the 4C-4911 Battery Load Tester or the 177-2330 Battery Analyzer in order to test a battery that does not maintain a charge when the battery is active. The 4C-4911 Battery Load Tester or the 177-2330 Battery Analyzer is a portable unit. The 4C-4911 Battery Load Tester or the 177-2330 Battery Analyzer can be used under field conditions and under high temperatures. The tester can be used to load test all 6, 8, and 12 Volt batteries. This tester has two heavy-duty load cables that can easily be fastened to the battery terminals. A load adjustment knob is located on the top of the tester. The load adjustment knob permits the current that is being drawn from the battery to be adjusted to a maximum of 1000 amperes. The tester is cooled by an internal fan that is automatically activated when a load is applied.

The tester has a built-in LCD. The LCD is a digital voltmeter. The LCD is a digital meter that will also display the amperage. The digital voltmeter accurately measures the battery voltage at the battery through wires for tracing. These wires are buried inside the load cables. The digital meter, that displays the amperage, accurately displays the current that is being drawn from the battery which is being tested.

Note: Refer to Operating Manual , SEHS9249 for detailed instruction on the use of the 4C-4911 Battery Load Tester. Refer to Operating Manual , NEHS0764 for detailed instruction on the use of the 177-2330 Battery Analyzer. See Special Instruction, SEHS7633, "Battery Test Procedure" for the correct procedures to use when you test the battery. This publication also contains the specifications to use when you test the battery.

i01660532

Belt Tension Chart

SMCS Code: 1357

Note: Do not use the belt tension charts for belts with tensioners that are spring loaded.

Table 27

Belt Tension Chart					
Size of Belt	Width of Belt	Gauge Reading		Kent-Moore Gauge Numbers	
		Belt Tension "Initial" ⁽¹⁾	Belt Tension "Used" ⁽²⁾⁽³⁾	Number of the Old Gauge	Number of the New Gauge
3/8	10.72 mm (0.422 inch)	534 ± 111 N (120 ± 25 lb)	400 ± 22 N (90 ± 5 lb)	BT-33-97	BT 3397
1/2	13.89 mm (0.547 Inch)	578 ± 111 N (130 ± 25 lb)	445 ± 44 N (100 ± 10 lb)	BT-33-97	BT 3397
5V	15.88 mm (0.626 Inch)	712 ± 111 N (160 ± 25 lb)	445 ± 44 N (100 ± 10 lb)	BT-33-72C	BT 3372C
11/16	17.48 mm (0.688 Inch)	712 ± 111 N (160 ± 25 lb)	445 ± 44 N (100 ± 10 lb)	BT-33-72C	BT 3372C
3/4	19.05 mm (0.750 Inch)	712 ± 111 N (160 ± 25 lb)	445 ± 44 N (100 ± 10 lb)	BT-33-72C	BT 3372C
15/16	23.83 mm (0.938 Inch)	712 ± 111 N (160 ± 25 lb)	445 ± 44 N (100 ± 10 lb)	BT-33-77	BT 3372C
8PK	27.82 mm (1.095 inch)	1068 ± 111 N (240 ± 25 lb)	890 ± 44 N (200 ± 10 lb)	BT-33-109	BT 33109
6PK	20.94 mm (0.824 Inch)	801 ± 111 N (180 ± 25 lb)	667 ± 44 N (150 ± 10 lb)	BT-33-109	BT 33109
Measure the tension of the belt that is farthest from the engine.					

⁽¹⁾ Belt tension "Initial" is for a new belt.

⁽²⁾ Belt tension "Used" is for a belt that has operated for 30 minutes or more of operation at the rated speed.

⁽³⁾ If a belt falls below the "Used" belt tension, the belt should be tightened again to the high side of the "Used" belt tension.

Table 28

DAYCO Supplied Belts Only		
Size of Belt	Belt Tension "Initial"	Belt Tension "Used" ⁽⁴⁾
0.380 (V-Belt)	623 ± 22 N (140 ± 5 lb)	245 - 534 N (100 ± 5 lb)
0.440 (V-Belt)	667 ± 22 N (150 ± 5 lb)	245 - 534 N (100 ± 5 lb)
0.500 (V-Belt)	712 ± 22 N (160 ± 5 lb)	245 - 534 N (100 ± 5 lb)
0.600 (V-Belt)	779 ± 22 N (175 ± 5 lb)	245 - 534 N (100 ± 5 lb)
0.660 (V-Belt)	890 ± 22 N (200 ± 5 lb)	245 - 534 N (100 ± 5 lb)
0.790 (V-Belt)	890 ± 22 N (200 ± 5 lb)	245 - 534 N (100 ± 5 lb)
4 - RIB PVK	623 ± 22 N (140 ± 5 lb)	267 - 445 N (90 ± 5 lb)
5 - RIB PVK	779 ± 22 N (175 ± 5 lb)	334 - 556 N (100 ± 5 lb)
6 - RIB PVK	934 ± 22 N (210 ± 5 lb)	400 - 667 N (130 ± 5 lb)
8 - RIB PVK	1157 ± 22 N (260 ± 5 lb)	534 - 890 N (180 ± 5 lb)
10 - RIB PVK	1557 ± 22 N (350 ± 5 lb)	667 - 1112 N (230 ± 5 lb)
12 - RIB PVK	1869 ± 22 N (420 ± 5 lb)	800 - 1335 N (270 ± 5 lb)
15 - RIB PVK	2336 ± 22 N (525 ± 5 lb)	1000 - 1669 N (350 ± 5 lb)

⁽⁴⁾ If a belt falls below the "Used" belt tension, the belt should be tightened again to the "Initial" belt tension.

i01852470

Charging System - Test

SMCS Code: 1406-081

The condition of charge in the battery at each regular inspection will show if the charging system is operating correctly. An adjustment is necessary when the battery is constantly in a low condition of charge or a large amount of water is needed. A large amount of water would be more than one ounce of water per a cell per a week or per every 100 service hours.

When it is possible, make a test of the charging unit and voltage regulator on the engine, and use wiring and components that are a permanent part of the system. Off-engine testing or bench testing will give a test of the charging unit and voltage regulator operation. This testing will give an indication of needed repair. After repairs are made, perform a test in order to prove that the units have been repaired to the original condition of operation.

Test Tools For The Charging System

Table 29

Tools Needed		
Part Number	Part Name	Quantity
8T-0900	Ammeter	1
6V-7070 or 146-4080	Digital Multimeter or Digital Multimeter	1

8T-0900 Ammeter

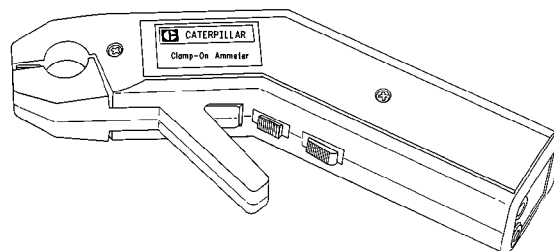

Illustration 91
8T-0900 Ammeter

g00296441

The **8T-0900** Ammeter is completely portable. This ammeter is a self-contained instrument that measures electrical currents without breaking the circuit and without disturbing the conductor's insulation.

The ammeter contains a digital display that is used to monitor current directly within a range between 1 ampere and 1200 amperes. If an optional **6V-6014** Cable is connected between this ammeter and a digital multimeter, current readings can be viewed directly from the display of the multimeter. This can be accomplished under only one condition:

- the readings are less than 1 ammeter.

A lever opens the ammeter's jaws over a conductor. The conductor's diameter can not be larger than 19 mm (0.75 inch).

The spring loaded jaws close around the conductor for measuring the current. A trigger switch controls the ammeter. The trigger switch can be locked into the ON position or into the OFF position.

After the trigger has been working and the trigger is turned to the OFF position, the reading appears in the digital display for five seconds. This accurately measures currents in areas with a limited access. For example, these areas include areas that are beyond the operator's sight. For DC operation, an ammeter contains a zero control, and batteries inside the handle supply the power.

Note: Refer to Special Instruction, SEHS8420 for more information about using the **8T-0900** Ammeter.

6V-7070 Digital Multimeter or 146-4080 Digital Multimeter

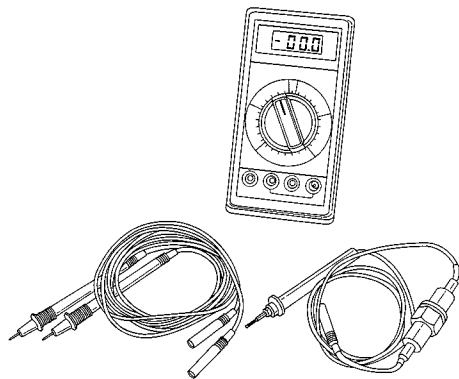

Illustration 92

g00283566

6V-7070 Digital Multimeter or 146-4080 Digital Multimeter

The **6V-7070** Digital Multimeter or the **146-4080** Digital Multimeter is a hand-held service tool with a digital display, that is completely portable. This multimeter is built with extra protection against damage in field applications. The multimeter is equipped with 7 functions and 29 ranges. The **6V-7070** Digital Multimeter or the **146-4080** Digital Multimeter has an instant ohms indicator. This indicator permits checking continuity for a fast inspection of the circuits. The multimeter can also be used for troubleshooting capacitors that have small values.

Note: Refer to Special Instruction, SEHS7734 for complete information for the use of the **6V-7070** Digital Multimeter. Refer to Operation Manual, NEHS0678 for complete information for the use of the **146-4080** Digital Multimeter.

i01665659

Electric Starting System - Test

SMCS Code: 1450-081

Most of the tests of the electrical system can be done on the engine. The wiring insulation must be in good condition. The wire and cable connections must be clean, and both components must be tight. The battery must be fully charged. If the on-engine test shows a defect in a component, remove the component for more testing.

The starting system consists of the following components:

- Keyswitch
- Starting motor solenoid
- Starting motor

Table 30

Tools Needed		
Part Number	Part Name	QTY
6V-7070 or 146-4080	Digital Multimeter	1

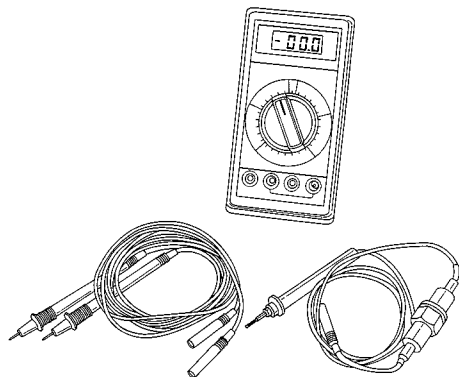

Illustration 93

g00283566

6V-7070 Digital Multimeter or the 146-4080 Digital Multimeter

The **6V-7070** Digital Multimeter or the **146-4080** Digital Multimeter is a hand-held service tool with a digital display, that is completely portable. This multimeter is built with extra protection against damage in field applications. The multimeter is equipped with 7 functions and 29 ranges. The **6V-7070** Digital Multimeter or the **146-4080** Digital Multimeter has an instant ohms indicator. This indicator permits checking continuity for a fast inspection of the circuits. The multimeter can also be used for troubleshooting capacitors that have small values.

Note: Refer to Special Instruction, SEHS7734 for complete information for the use of the **6V-7070** Digital Multimeter. Refer to Operation Manual, NEHS0678 for complete information for the use of the **146-4080** Digital Multimeter.

Use the multimeter in the DCV range to find starting system components which do not function.

Move the start control switch in order to activate the starting solenoids. The starting solenoid's operation can be heard as the pinions of the starting motors are engaged with the ring gear on the engine flywheel.

If a solenoid for a starting motor will not operate, it is possible that the current from the battery did not reach the solenoid. Fasten one lead of the multimeter to the terminal connection for the battery cable on the solenoid. Touch the other lead to a good ground. A zero reading indicates that there is a broken circuit from the battery. More testing is necessary when there is a voltage reading on the multimeter.

The solenoid operation also closes the electric circuit to the motor. Connect one lead of the multimeter to the terminal connection of the solenoid that is fastened to the motor. Touch the other lead to a good ground. Activate the starting solenoid and look at the multimeter. A reading of the battery voltage shows that the problem is in the motor. The motor must be removed for further testing. A zero reading on the multimeter shows that the solenoid contacts do not close. This is an indication of the need for repair to the solenoid or an adjustment to be made to the pinion clearance for the starting motor.

Perform a test. Fasten one multimeter lead to the terminal connection for the small wire at the solenoid and fasten the other lead to the ground. Look at the multimeter and activate the starting solenoid. A voltage reading shows that the problem is in the solenoid. A zero reading indicates that the problem is in the start switch or the wires for the start switch.

Fasten one multimeter lead to the start switch at the terminal connection for the wire from the battery. Fasten the other lead to a good ground. A zero reading indicates a broken circuit from the battery. Make a check of the circuit breaker and wiring. If there is a voltage reading, the problem is in the start switch or in the wires for the start switch.

Starting motors that operate too slowly can have an overload because of too much friction in the engine that is being started. Slow operation of the starting motors can also be caused by a short circuit, loose connections and/or dirt in the motors.

i01854743

Engine Oil Pressure Sensor - Test

SMCS Code: 1924-081

Refer to the Troubleshooting, SENR9819, "PC-42: Engine Oil Pressure Sensor Open Or Short Circuit Test" for information on checking the engine oil pressure sensor.

Index

A

Aftercooler - Test	75
Aftercooler Core Leakage	76
Air System Restriction	77
Dynamometer Test.....	78
Turbocharger Failure.....	78
Visual Inspection.....	75
Air in Fuel - Test.....	60
Air Inlet and Exhaust System	44, 68
Air Inlet Heater	46
Turbocharger.....	45
Valve System Components.....	46
Air Inlet and Exhaust System - Inspect.....	68
Air Inlet Restriction.....	68
Exhaust Back Pressure.....	69
Exhaust Restriction.....	69

B

Basic Engine.....	55, 96
Camshaft.....	56
Crankshaft.....	55
Cylinder Block And Head	55
Piston, Rings And Connecting Rods.....	55
Vibration Damper.....	56
Battery - Test	101
Belt Tension Chart.....	102

C

Charging System - Test	103
Test Tools For The Charging System.....	103
Compression - Test.....	79
Connecting Rod Bearings - Inspect.....	96
Cooling System	52, 87
Coolant Conditioner (If Equipped).....	54
Coolant For Air Compressor (If Equipped).....	54
Cooling System - Check (Overheating)	87
Cooling System - Inspect.....	89
Cooling System - Test.....	90
Checking the Filler Cap.....	92
Making the Correct Antifreeze Mixtures.....	92
Test For The Water Temperature Gauge	94
Test Tools For Cooling System	90
Testing The Radiator And Cooling System For Leaks.....	93
Cylinder Block - Inspect.....	96

E

Electric Starting System - Test	104
Electrical System	57, 101
Engine Electrical System	58
Grounding Practices	57

Electronic Control System Components.....	11
Engine Crankcase Pressure (Blowby) - Test	78
Engine Design	4
Engine Oil Pressure - Test.....	82
Measuring Engine Oil Pressure	82
Reason for High Engine Oil Pressure	84
Reasons for Low Engine Oil Pressure	83
Engine Oil Pressure Sensor - Test	105
Engine Oil Pump - Inspect.....	85
Engine Speed - Check.....	61
Engine Valve Lash - Inspect/Adjust	79
Valve Lash and Valve Bridge Adjustment	80
Valve Lash Check	79
Excessive Bearing Wear - Inspect.....	85
Excessive Engine Oil Consumption - Inspect.....	85
Oil Leakage Into Combustion Area Of Cylinders	85
Oil Leakage On Outside Of Engine.....	85
Exhaust Temperature - Test.....	75

F

Finding Top Center Position for No. 1 Piston	62
Flywheel - Inspect.....	97
Bore Runout (radial eccentricity) of the Flywheel.....	97
Face Runout (axial eccentricity) of the Flywheel	97
Flywheel Housing - Inspect	98
Bore Runout (Radial Eccentricity) of the Flywheel Housing.....	98
Face Runout (Axial Eccentricity) of the Flywheel Housing.....	98
Fuel Quality - Test.....	63
Fuel System.....	15, 59
Component Description	16
Components of the HEUI Injector	29
Fuel Heater And Water Separator (If Equipped)..	43
HEUI Fuel System Operation.....	18
Introduction	15
Operation of the HEUI Fuel Injector.....	33
Fuel System - Inspect.....	59
Checking The Operation Of Individual Cylinders	60
Initial Inspection Of The Fuel System	59
Inspection With The Engine Running.....	60
Start Up Procedure	59
Fuel System - Prime	63
Fuel System Pressure - Test	64

G

Gear Group (Front) - Time.....	66
General Information.....	5
Cold Mode Operation.....	7
Starting The Engine	7

Glossary of Electronic Control Terms 7

I

Important Safety Information 2
Increased Engine Oil Temperature - Inspect 86
Inlet Manifold Pressure - Test 74

L

Lubrication System 50, 82

M

Main Bearings - Inspect 96

P

Piston Ring Groove - Inspect 96

S

Systems Operation Section 4

T

Table of Contents 3
Testing and Adjusting Section 59
Turbocharger - Inspect 71
 Inspection of the Compressor and the Compressor
 Housing 71
 Inspection of the Turbine Wheel and the Turbine
 Housing 72
 Inspection of the Wastegate 72

U

Unit Injector - Test 66

V

Vibration Damper - Check 100
 Rubber Vibration Damper 100

W

Water Pump - Test 95
Water Temperature Regulator - Test 94

Troubleshooting

3126E Truck Engine

LEF1-Up (Engine)



Important Safety Information

Most accidents that involve product operation, maintenance and repair are caused by failure to observe basic safety rules or precautions. An accident can often be avoided by recognizing potentially hazardous situations before an accident occurs. A person must be alert to potential hazards. This person should also have the necessary training, skills and tools to perform these functions properly.

Improper operation, lubrication, maintenance or repair of this product can be dangerous and could result in injury or death.

Do not operate or perform any lubrication, maintenance or repair on this product, until you have read and understood the operation, lubrication, maintenance and repair information.

Safety precautions and warnings are provided in this manual and on the product. If these hazard warnings are not heeded, bodily injury or death could occur to you or to other persons.

The hazards are identified by the "Safety Alert Symbol" and followed by a "Signal Word" such as "DANGER", "WARNING" or "CAUTION". The Safety Alert "WARNING" label is shown below.



The meaning of this safety alert symbol is as follows:

Attention! Become Alert! Your Safety is Involved.

The message that appears under the warning explains the hazard and can be either written or pictorially presented.

Operations that may cause product damage are identified by "NOTICE" labels on the product and in this publication.

Caterpillar cannot anticipate every possible circumstance that might involve a potential hazard. The warnings in this publication and on the product are, therefore, not all inclusive. If a tool, procedure, work method or operating technique that is not specifically recommended by Caterpillar is used, you must satisfy yourself that it is safe for you and for others. You should also ensure that the product will not be damaged or be made unsafe by the operation, lubrication, maintenance or repair procedures that you choose.

The information, specifications, and illustrations in this publication are on the basis of information that was available at the time that the publication was written. The specifications, torques, pressures, measurements, adjustments, illustrations, and other items can change at any time. These changes can affect the service that is given to the product. Obtain the complete and most current information before you start any job. Caterpillar dealers have the most current information available.



When replacement parts are required for this product Caterpillar recommends using Caterpillar replacement parts or parts with equivalent specifications including, but not limited to, physical dimensions, type, strength and material.

Failure to heed this warning can lead to premature failures, product damage, personal injury or death.

Table of Contents

Troubleshooting Section

Electronic Troubleshooting

System Overview	5
Glossary	14
Electronic Service Tools	20
Sensors and Electrical Connectors	22
Engine Wiring Harness Diagram	26

Programming Parameters

Programming Parameters	27
Customer Passwords	29
ECM Date/Time Stamped Information	29
ECM Snapshot	30
Factory Passwords	32
Factory Passwords Worksheet	33
Flash Programming	33
Service Information Report	34

Customer Specified Parameters

Customer Specified Parameters	35
Customer Specified Parameters Table	36
Customer Specified Parameters Worksheet	41
Cruise Control Parameters	44
Data Link Parameters	46
Dedicated PTO Parameters	46
Engine/Gear Parameters	49
Engine Monitoring Parameters	52
Idle Parameters	53
Input Selections	55
Maintenance Parameters	59
Output Selections	59
Passwords	62
Selected Engine Rating	62
Smart Idle Parameters	62
Trip Parameters	62
Truck Manufacture Parameters	64
Timer Parameters	64
Vehicle Speed Parameters	65

System Configuration Parameters

System Configuration Parameters	68
---------------------------------------	----

Troubleshooting without a Diagnostic Code

Can Not Reach Top Engine RPM	69
Can Not Reach Vehicle Speed Limit	70
Check Engine Lamp or Warning Lamp Is Malfunctioning	72
Cruise Control, Idle, or PTO Can Not Be Set	73
Driver Questionnaire	76
Driver Questionnaire Response	77
ECM Will Not Accept Factory Passwords	78
Electronic Service Tool Will Not Communicate with ECM	79
Elevated Idle	80
Engine Cranks but Will Not Start	80
Engine Has Early Wear	83
Engine Misfires, Runs Rough or Is Unstable	84
Engine Vibration	85

Engine Will Not Crank	86
Excessive Black Smoke	87
Excessive Valve Lash	87
Excessive White Smoke	88
Intermittent Cruise Control, Idle, or PTO Kickout ..	89
Intermittent Engine Shutdown	91
Intermittent Low Power or Power Cutout	92
Low Power/Poor or No Response to Throttle	94
Poor Acceleration or Response	97

Troubleshooting with a Diagnostic Code

No Diagnostic Code Detected (55)	99
0001-11 Cylinder 1 Fault (72)	99
0002-11 Cylinder 2 Fault (72)	99
0003-11 Cylinder 3 Fault (73)	100
0004-11 Cylinder 4 Fault (73)	100
0005-11 Cylinder 5 Fault (74)	101
0006-11 Cylinder 6 Fault (74)	101
0022-13 Check Timing Sensor Calibration (42) ..	102
0030-08 Invalid PTO Throttle Signal (29)	102
0030-13 PTO Throttle Sensor Calibration (29) ...	102
0041-03 8 Volt Supply Above Normal (21)	103
0041-04 8 Volt Supply Below Normal (21)	103
0042-11 Injection Actuation Pr Control Valve Driver (18)	103
0043-02 Ignition Key Switch Fault (71)	104
0064-02 Loss of Engine RPM Signal #2 (34)	104
0064-11 No Pattern on Speed Sensor #2 (34) ...	104
0070-05 Inlet Air Heater Open Circuit (49)	105
0070-06 Inlet Air Heater Short Circuit (49)	105
0071-00 Idle Shutdown Override (01)	105
0071-01 Idle Shutdown Occurrence (47)	106
0071-14 PTO Shutdown Timer Occurrence (47)	106
0084-00 Vehicle Overspeed Warning (41)	106
0084-01 Loss of Vehicle Speed Signal (31)	107
0084-02 Invalid Vehicle Speed Signal (36)	107
0084-08 Vehicle Speed Out of Range (36)	107
0084-10 Vehicle Speed Rate of Change (36)	108
0091-08 Invalid Throttle Signal (32)	108
0091-13 Throttle Sensor Calibration (28)	109
0096-03 Primary Fuel Level Sensor Open Circuit (44)	109
0096-04 Primary Fuel Level Sensor Short Circuit (44)	109
0100-03 Oil Pressure Sensor Open Circuit (24) ..	110
0100-04 Oil Pressure Sensor Short Circuit (24) ..	110
0100-11 Very Low Oil Pressure (46)	110
0102-00 Boost Pressure Reading Stuck High (25)	112
0102-03 Boost Pressure Sensor Open Circuit (25)	112
0102-04 Boost Pressure Sensor Short Circuit (25)	112
0102-07 Excessive Boost Pressure	113
0105-00 High Inlet Manifold Temp Warning (64) ..	113
0105-03 Inlet Manifold Temp Sensor Open Circuit (38)	115
0105-04 Inlet Manifold Temp Sensor Short Circuit (38)	115
0105-11 Very High Inlet Manifold Temp (64)	116
0108-03 Atmospheric Pr Sensor Open Circuit (26)	118

Table of Contents

0108-04 Atmospheric Pr Sensor Short Circuit (26)	118	ATA (SAE J1587 / J1708) Data Link Circuit - Test	161
0110-00 High Coolant Temperature Warning (61)	118	Change Oil Lamp Circuit - Test	167
0110-03 Coolant Temp Sensor Open Circuit (27)	120	Check Engine Lamp Circuit - Test	170
0110-04 Coolant Temp Sensor Short Circuit (27)	121	Clutch Pedal Position Switch Circuit - Test	175
0110-11 Very High Coolant Temperature (61)	121	Coolant Level Sensor Circuit - Test	187
0111-01 Low Coolant Level Warning (62)	124	Cooling Fan Circuit and A/C Compressor Clutch Circuit - Test	196
0111-02 Coolant Level Sensor Fault (12)	125	Cooling Fan Circuit and A/C High Pressure Switch Circuit - Test	204
0111-03 Coolant Level Sensor Open Circuit (12)	126	Cruise Control Switch Circuit - Test	219
0111-04 Coolant Level Sensor Short Circuit (12)	126	ECM Memory - Test	233
0111-11 Very Low Coolant Level (62)	127	Electrical Connectors - Inspect	236
0128-03 Secondary Fuel Level Sensor Open Circuit (44)	128	Engine Pressure Sensor Open or Short Circuit - Test	243
0128-04 Secondary Fuel Level Sensor Short Circuit (44)	129	Engine Running Output Circuit - Test	251
0164-00 Injection Actuation Pr Out of Range (17)	129	Engine Speed/Timing Sensor Circuit - Test	254
0164-02 Injection Actuation Pr Sensor Erratic (15)	130	Engine Temperature Sensor Open or Short Circuit - Test	260
0164-03 Injection Actuation Pr Sensor Open Circuit (15)	130	Exhaust Brake Circuit - Test	265
0164-04 Injection Actuation Pr Sensor Short Circuit (15)	130	Exhaust Particulate Filter Circuit - Test	271
0164-11 Injection Actuation Pressure System (39)	131	Fast Idle Enable Circuit - Test	273
0168-02 Intermittent Battery (51)	131	Fast Idle Lamp Circuit - Test	277
0186-04 PTO Engine Shutdown Short Circuit	131	Fuel Level Sensor Circuit - Test	280
0186-14 PTO Shutdown Switch Occurrence (47)	132	Idle Shutdown Timer - Test	284
0190-00 Engine Overspeed Warning (35)	132	Ignition Key Switch Circuit and Battery Supply Circuit - Test	287
0190-02 Loss of Engine RPM Signal (34)	132	Ignore Brake/Clutch Switch Circuit - Test	294
0190-11 No Pattern on Speed Sensor #1 (34) ...	133	Injection Actuation Pressure - Test	298
0224-11 Theft Deterrent Active (00)	133	Injection Actuation Pressure Control Valve Circuit - Test	303
0224-14 Engine Cranking with Theft Deterrent Active (00)	134	Injection Actuation Pressure Sensor - Test	308
0231-02 J1939 Required Data Not Received (58)	134	Injector Solenoid Circuit - Test	311
0231-11 J1939 Data Link Fault (58)	134	Input Selection Switch Circuit - Test	318
0231-12 J1939 Device Not Responding	135	Neutral Switch Circuit - Test	324
0232-03 5 Volt Supply Above Normal (21)	135	Powertrain Data Link Circuit - Test	337
0232-04 5 Volt Supply Below Normal (21)	136	PTO Engine Shutdown Switch Circuit - Test	345
0246-11 Brake Switch #1	136	PTO Shutdown Timer - Test	349
0247-11 Brake Switch #2	137	PTO Switch Circuit - Test	351
0252-11 Incorrect Engine Software (59)	137	PTO Switch ON Lamp Circuit - Test	361
0253-02 Check Customer or System Parameters (56)	137	Remote PTO Accelerator Position Sensor Circuit - Test	366
0253-14 Truck Manufacturer Parameter Not Programed	138	Service Brake Pedal Position (Switch 1) Circuit - Test	373
Diagnostic Functional Tests		Service Brake Pedal Position (Switch 2) Circuit - Test	385
5 Volt Engine Pressure Sensor Supply Circuit - Test	139	Starting Aid Output Circuit - Test	397
Accelerator Pedal (Throttle) Position Sensor Circuit - Test	143	Tachometer Circuit - Test	399
Air Inlet Heater Circuit - Test	151	Transmission (AT/MT/HT) Relay Circuit - Test	405
		Vehicle Speed and Speedometer Circuit - Test ..	408
		Wait To Start Lamp Circuit - Test	417
		Warning Lamp Circuit - Test	421
		Calibration Procedures	
		Engine Speed/Timing Sensor - Calibrate	425
		Vehicle Speed Circuit - Calibrate	427
		Index Section	
		Index	430

Troubleshooting Section

Electronic Troubleshooting

i01857056

System Overview

SMCS Code: 1900

System Operation

The engine uses a Hydraulic Electronic Unit Injector fuel system. The injection pump, the fuel lines and the nozzles that are used in mechanical engines have been replaced with an hydraulic electronic unit injector in each cylinder. A solenoid on each injector controls the amount of fuel that is delivered by the injector. An axial piston pump increases the engine oil pressure in order to activate the injector. An Engine Control Module (ECM) sends a signal to the injection actuation pressure control valve in order to control injection pressure. Another electrical signal is sent to each injector solenoid in order to inject fuel.

Electronic Controls

The engine's electronic system consists of the Engine Control Module (ECM), the engine sensors, the injection actuation pressure control valve, and the vehicle interface. The ECM is the computer. The personality module is the software for the computer. The personality module contains the operating maps. The operating maps define the following characteristics of the engine:

- Horsepower
- Torque curves
- Engine speed (rpm)

Engine Governor

The electronic controls on the engine serves as the engine governor. The electronic control system determines:

- The timing of the fuel delivery to the cylinders
- The amount of fuel that is delivered to the cylinders
- Injection pressure

The electronic control system uses the actual conditions and the desired conditions in order to make the decisions. The electronic control system controls the engine during starting and operation.

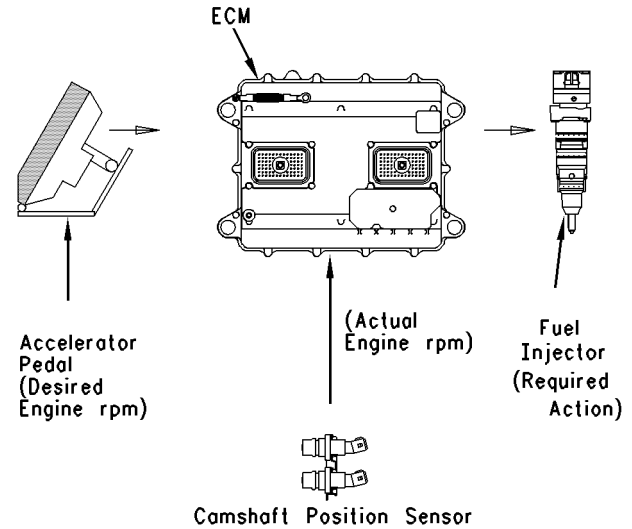

Illustration 1

g00693055

The governor considers the desired conditions and the actual conditions. The governor then takes the action that best accommodates the desired conditions. The desired conditions are typically the accelerator pedal position, the desired vehicle speed during cruise control, or the desired engine speed during PTO control. The actual conditions are based on current operating conditions such as coolant temperature, load conditions, etc.

Timing Considerations

Once the ECM has determined the amount of fuel that is required, the ECM must then determine when the injection is needed. Injection timing is determined by the ECM after considering input from the coolant temperature sensor, the sensor for the intake air temperature, and the boost pressure sensor.

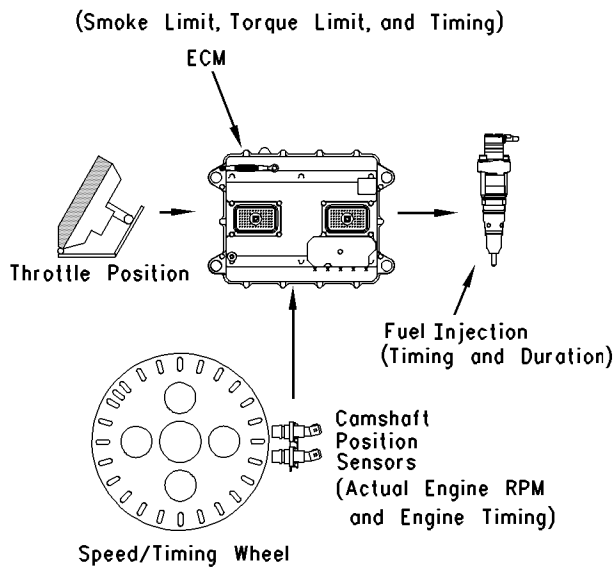

Illustration 2

g00693339

The ECM knows the cylinder position for timing because of the signal from the engine speed/timing sensors. The ECM adjusts timing for best engine performance, for fuel economy, and for the control of white smoke. Actual timing and desired timing cannot be viewed with the electronic service tool. The ECM determines the location of top center of the number one cylinder from the signal that is provided by the engine speed/timing sensors. The ECM decides when injection should occur relative to top center. The ECM then provides the signal to the injector at the desired time.

Fuel Injection

The ECM controls the amount of fuel that is injected by varying the signals to the injectors. The injectors will pump fuel only if the injector solenoid is energized. The ECM sends a high voltage signal in order to energize the solenoid. The injector solenoid unseats the poppet valve. The oil path to the drain passage will close while the inlet oil passage opens for the high pressure oil. The high pressure oil enters the injector and pushes on the intensifier piston. This causes the fuel pressure to increase. The diesel fuel is then injected into the combustion chamber. By controlling the timing and the duration of the high voltage signal, the ECM can control injection timing and the ECM can control the amount of fuel that is injected.

The ECM controls the fuel pressure that is injected into the cylinder by controlling the injection actuation pressure control valve. The output pressure of the injection actuation pressure control valve is a dump valve that is controlling the output pressure of the high pressure oil pump.

The personality module inside the ECM sets certain limits on the amount of fuel that can be injected. The “FRC Fuel Limit” is a limit that is based on the boost pressure. The “FRC Fuel Limit” is used to control the air/fuel ratio for control of emissions. When the ECM senses a higher boost pressure, the ECM increases the “FRC Fuel Limit”. A higher boost pressure indicates that there is more air in the cylinder. When the ECM increases the “FRC Fuel Limit”, the ECM allows more fuel into the cylinder.

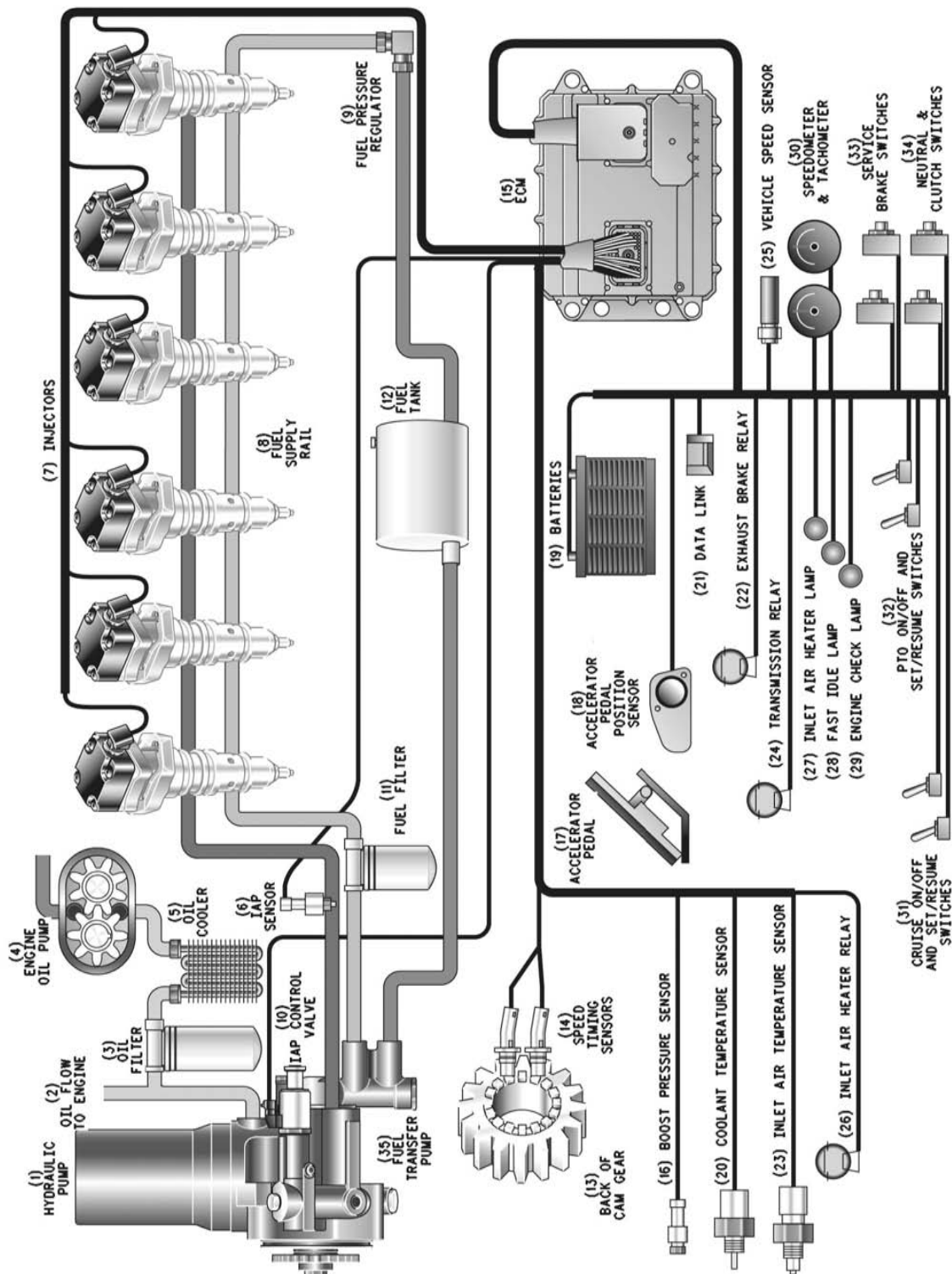

Illustration 3

HEUI Fuel System

(1) Hydraulic pump. (2) Oil flow to engine. (3) Oil filter. (4) Engine oil pump. (5) Oil cooler. (6) IAP sensor. (7) Injectors. (8) Fuel supply rail. (9) Fuel pressure regulator. (10) IAP control valve. (11) Fuel filter. (12) Fuel tank. (13) Back of cam gear. (14) Speed/Timing sensors. (15) ECM. (16) Boost pressure sensor. (17) Accelerator pedal. (18) Accelerator pedal position sensor. (19) Batteries. (20) Coolant temperature sensor. (21) Data link. (22) Exhaust brake relay. (23) Inlet air temperature sensor. (24) Transmission relay. (25) Vehicle speed sensor. (26) Inlet air heater relay. (27) Air inlet heater. (28) Fast idle lamp. (29) Check engine lamp. (30) Speedometer and tachometer. (31) Cruise ON/OFF switch and SET/RESUME switch. (32) PTO ON/OFF switch and SET/RESUME switch. (33) Service brake switches. (34) Neutral and clutch switches. (35) Fuel transfer pump.

The “Rated Fuel Limit” is a limit that is based on the power rating of the engine and engine rpm. The “Rated Fuel Limit” is similar to the rack stops and the torque spring on a mechanically governed engine. The “Rated Fuel Limit” provides the power curves and the torque curves for a specific engine family and a specific engine rating. All of these limits are determined at the factory. These limits are in the personality module and these limits cannot be changed.

Injection Actuation Pressure Control System

The ECM controls fuel injection by controlling oil pressure to the fuel injectors. The pressure of the oil in the high pressure oil manifold is controlled by the ECM through control of the injection actuation pressure control valve. The injection actuation pressure control valve (dump valve) controls the high pressure pump outlet pressure by dumping excess flow back to the oil sump.

The ECM monitors the pressure in the high pressure manifold through the injection actuation pressure sensor. The injection actuation pressure sensor is located in the top of the manifold on the left side of the engine. The injection actuation pressure sensor’s signal is compared by the ECM to the desired injection actuation pressure. The injection actuation pressure sensor’s signal is based on sensor inputs. The sensor inputs are used to adjust the position of the injection actuation pressure control valve in order to adjust the oil pressure in the high pressure manifold.

High pressure oil is routed from the pump to the high pressure manifold through a steel tube. From the manifold, the oil is routed to each injector through the high pressure oil manifold. All injectors have a constant supply of oil while the engine is running. Disabling the electrical signal to the injector solenoid does not interrupt the oil flow to the fuel injector.

Cold Mode

Cold Mode is activated when the sum of coolant temperature and the inlet manifold air temperature is below 18 °C (64 °F). When Cold Mode begins, the idle rpm speed ramps up to the default value of 1000 rpm unless another value has been programmed into the “Warm Up Mode Idle Speed” parameter. Cold Mode stays active until any of the following conditions are met:

- The sum of coolant temperature and the inlet manifold air temperature reaches 18 °C (64 °F).
- 12 minutes have expired.

- The service brake is depressed.
- The clutch pedal is depressed.
- The automatic transmission is placed in gear.

Customer Parameters and Engine Speed Governing

A unique feature with electronic engines is Customer Specified parameters. These parameters allow the vehicle owner to fine tune the ECM for engine operation. Fine tuning the ECM for engine operation allows the vehicle owner to accommodate the typical usage of the vehicle and the power train of the vehicle.

Many of the customer parameters provide additional restrictions on the actions that will be performed by the ECM in response to the driver’s input. For example, the “PTO Top Engine Limit” is an engine rpm limit. The “PTO Top Engine Limit” is an engine rpm limit that is used by the ECM as a cutoff for the fuel. The ECM will not fuel the injectors above this rpm.

Some parameters are intended to notify the driver of potential engine damage (Engine Monitoring Parameters). Some parameters enhance fuel economy (Vehicle Speed, Cruise Control, Engine/Gear Speed Limit Parameter and Idle Shutdown). Other parameters are used to enhance the engine installation into the vehicle. Other parameters are also used to provide engine operating information to the truck engine owner.

Engine Monitoring

Caterpillar provides a factory installed engine monitoring system. The Caterpillar Engine Monitoring system monitors the following variables:

- Coolant temperature
- Inlet manifold air temperature
- Coolant level (optional variable)
- Engine oil pressure (optional variable)

Caterpillar Engine Monitoring can be programmed to four different modes. The four modes of programming are “OFF”, “WARNING”, “DERATE”, and “SHUTDOWN”. The sensors will operate in the engine monitoring mode that is selected.

Caterpillar Engine Monitoring

“Off” Operation

This option is not applicable for OCT01 software.

If Caterpillar Engine Monitoring is programmed to “OFF”, the ECM will not flag high coolant temperature or high inlet manifold air temperature. No warnings will occur even though conditions that could cause the ECM to take action (engine monitoring) are exceeded.

The ECM still uses the sensors for engine operation. The coolant temperature sensor is still used for cold mode operation, control of the air inlet heater, and control of the cooling fan. The inlet manifold temperature is still used for operation in cold air, control of the air inlet heater, and control of the cooling fan. The coolant level is not used even if a coolant level sensor is installed.

“WARNING” Operation

If Caterpillar Engine Monitoring is programmed to “WARNING”, the ECM will illuminate the Warning lamp and the ECM will flash the Check Engine lamp because of the active diagnostic code. The flashing lamp indicates that a problem has been detected by the engine monitoring system. The diagnostic code is logged. No further action by the ECM or action by the engine occurs if the ECM is programmed to “WARNING”.

“DERATE” Operation

If the system is programmed to “DERATE”, the ECM begins by flashing the Check Engine lamp and the Warning lamp. The flashing lamps indicate that a problem has been detected by the engine monitoring system. The diagnostic code is logged. High coolant temperature will signal the ECM to limit the maximum vehicle speed and the ECM will reduce the engine power rating. Refer to Illustration 4 and Illustration 6.

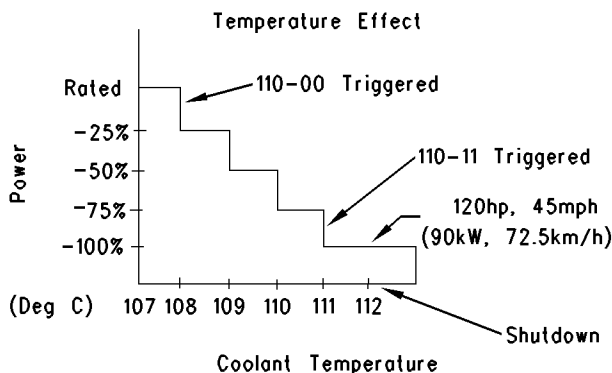

Illustration 4
Coolant temperature bargraph
Derate mode is limited. (10% per second)

Low coolant level will signal the ECM to limit the maximum vehicle speed and the ECM will reduce the engine power rating. Refer to Illustration 5.

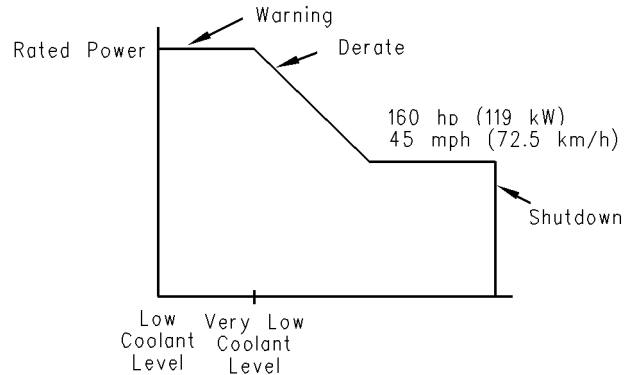

Illustration 5
Graph for the coolant level
Derate mode is limited. (10% per second)

Very low oil pressure will signal the ECM to limit the maximum vehicle speed and the ECM will reduce the engine power rating. Refer to Illustration 6.

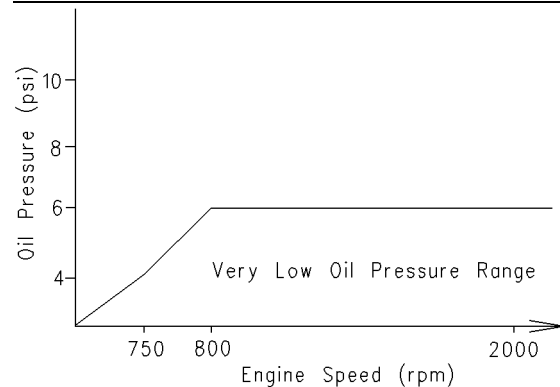

Illustration 6
Graph for very low oil pressure

This derating of engine performance is provided in order to get the driver’s attention so the driver can take action in order to avoid engine damage.

“SHUTDOWN” Operation

If the system is programmed to “SHUTDOWN”, the ECM takes all the action that is indicated for the “DERATE” mode and the ECM will eventually shut down the engine under some conditions.

The “SHUTDOWN” mode begins when any of the following conditions exist:

- “Very low oil pressure”
- “Very low coolant level”
- “Very high coolant temperature”

“SHUTDOWN” mode begins by flashing the warning lamp. This response is similar to the response when the system is in “DERATE”. “SHUTDOWN” mode will eventually shut down the engine if the conditions continue for a long enough time and the conditions are severe enough. The engine can be restarted as many times as needed after an Engine Monitoring Shutdown. This allows the vehicle to be pulled off of the road.

Other ECM Functions of Performance

The ECM also provides enhanced control of the engine for vehicle functions such as exhaust brake control. Refer to Troubleshooting, “Customer Specified Parameters” for supplemental information about the systems that can be monitored by the ECM in order to provide enhanced vehicle performance, fuel economy and convenience for the driver.

Self-Diagnostics

The electronic system has the ability to diagnose problems. When a problem is detected, a diagnostic code is generated and the check engine/diagnostic lamp may be turned on. In most cases, the code is also stored in permanent memory or logged in the ECM.

When diagnostic codes occur, the diagnostic codes are called active diagnostic codes. Active diagnostic codes indicate that a problem of some kind currently exists. Active diagnostic codes should always be serviced before any other work is performed. If a truck is brought in with an active code, find the code in the table of contents and proceed to diagnose the cause.

Diagnostic codes that are stored in memory are called logged diagnostic codes. Logged diagnostic codes do not necessarily indicate that something needs to be repaired. The problem may have been temporary, or the problem may have been repaired since the problem was logged. Logged diagnostic codes are instead meant to be an indication of probable causes for intermittent problems.

Diagnostic codes that identify operating conditions outside the normal operating range are called events. Event codes are not typically an indication of an electronic system problem.

Some of the diagnostic codes require passwords to be cleared from memory. Diagnostic codes that do not require passwords to be cleared from memory are automatically deleted after 50 hours of engine operation.

Engine Snapshot Data

Whenever most diagnostic codes occur, the ECM records the time in engine hours of the occurrence. Also, the ECM records the operating parameters of the engine for 9.6 seconds before the diagnostic code and 3.4 seconds after the diagnostic code. The operating parameters of the engine that are recorded are similar to the operating parameters of the engine that are displayed in the status screens of the Electronic Technician. Not all of the status screens of the Electronic Technician or parameters are recorded. The Engine Snapshot can also be triggered from the cruise control set/resume switch. In order to trigger the Engine Snapshot from the cruise control set/resume switch, quickly toggle the switch to the Set position. Then, quickly toggle the switch to the Resume position. You can also toggle the cruise control set/resume switch from the Resume position to the Set position. The Engine Snapshot can also be triggered from the Electronic Technician.

Effect Of Diagnostic Codes on Engine Performance

The discussion on engine monitoring mentions that the check engine lamp flashes when a specific condition exists. When the ECM detects the engine problem, the ECM generates an active diagnostic code. Also, the ECM logs the diagnostic code in order to indicate the time of the problem's occurrence. The ECM also logs the number of occurrences of the problem. There are two types of diagnostic codes. There are fault codes and event codes.

Diagnostic Fault Codes

Diagnostic fault codes are provided in order to indicate that an electrical problem or an electronic problem has been detected by the ECM. In some cases, the engine performance can be affected when the condition that is causing the code exists. More frequently, the driver cannot detect any difference in the engine performance.

If the check engine lamp is flashing and the driver indicates that a performance problem occurs, the diagnostic code may indicate the cause of the problem. The problem should be corrected.

If the driver does not indicate a problem with the engine performance and a diagnostic code is logged by the ECM, the situation indicates that the ECM detected an abnormal condition, but the abnormal condition did not affect engine performance.

In this situation, the system has no faults except when either of the following conditions exist:

- There are several occurrences of the diagnostic code in a very short period of time.
- The ECM is indicating an active code at the present time.

Diagnostic Event Codes

Diagnostic event codes are used to indicate that some operational problem has been detected in the engine or in the truck by the ECM. Usually, this does not indicate an electronic malfunction.

The ECM also provides an ECM date/time clock that is used to time stamp the following diagnostic event codes:

- 84-00 Vehicle Overspeed Warning (41)
- 100-11 Very Low Oil Pressure (46)
- 110-11 Very High Coolant Temperature (61)
- 111-11 Very Low Coolant Level (62)
- 190-00 Engine Overspeed Warning (35)

ECM Lifetime Totals

The ECM maintains total data of the engine for the following parameters:

- Total Time (Engine Hours)
- Total Distance
- PTO Time and PTO Fuel
- Idle Time and Idle Fuel
- Average Load Factor (Engine)
- Total Fuel
- Total Maximum Fuel

The total time is the engine's operating hours. The engine hours do not include operating time when the ECM is powered ON but the engine is not running.

Distance data requires a vehicle speed sensor or an electronic vehicle speed source to be connected to the ECM. The same sensor is used for ECM vehicle speed. Distance can be displayed in miles or kilometers.

PTO time and PTO fuel are logged when engine rpm is set by using the cruise switches and the engine is operating under some load. Also, PTO time and PTO fuel are logged when the PTO on/off switch is in the ON position and vehicle speed is within the range of the "PTO Vehicle Speed Limit" parameter.

Idle time and idle fuel can include operating time when all of the following conditions are met:

- When engine speed is set by using the cruise switches and the vehicle speed is within the range of the "Idle Vehicle Speed Limit" parameter.
- The engine is not operating under a load.

Fuel information can be displayed in US gallons or liters.

"Average Load Factor" provides relative engine operating information. Engine load factor compares actual engine operation information to the maximum engine operation that is available. "Average Load Factor" is determined by using "Total Maximum Fuel", "Idle Fuel", and Fuel Consumption. "Total Maximum Fuel" is the maximum amount of fuel that is used by the engine during operation. All of these parameters are available by using with the electronic service tool. These parameters are available within the menu for current tools.

Trip Data that is Stored in the ECM

The Fleet Trip Data allows the tracking of engine operation by the vehicle owner over intervals that are defined by the vehicle owner (July 1999 and newer personality modules). All of the trip data is stored in memory and the trip data is maintained through the unswitched battery lines when the ignition switch is off. An internal battery will maintain this information while the unswitched battery lines are disconnected.

Fleet Trip Data

Fleet Trip Data includes a "Fleet Trip Segment", histograms, and custom data. The "Fleet Trip Segment" includes data for the following parameters:

- Time (engine hours)
- Driving Time
- Distance
- Fuel
- Idle Time
- Idle Fuel

- PTO Time
- PTO Fuel
- Average Load Factor
- Average Vehicle Speed
- Percent Idle Time
- Percent PTO Time
- Overall Fuel Economy
- Driving Fuel Economy
- Average Driving Speed
- Maximum Vehicle Speed
- Maximum Engine Speed
- Start Time
- End Time
- Start Odometer
- End Odometer

Three histograms are available. One histogram records the engine's operation versus the engine speed. The second histogram records time versus vehicle speed. The third histogram records time versus "engine speed" and "vehicle speed".

The electronic service tool calculates the percentage of time that is spent in each of the engine rpm or vehicle speed ranges. Custom data is available. Custom data allows the recording of engine parameters that are specified by the vehicle owner. The ECM records the custom data.

A reset of the Fleet Trip Data which includes the "Fleet Trip Segment", the histograms, and the custom data can be done in several ways. The following tools can be used to reset the Fleet Trip Data:

- The electronic service tool which may require customer passwords
- Caterpillar Fleet Information Software (FIS)
- Caterpillar Messenger which requires Customer Parameters Programming to provide access

When the data is reset, the ECM records the current totals at the time of the reset. These totals are used as the starting point for the fleet trip. The following tools access the recorded starting point:

- Electronic Service Tool
- Caterpillar Fleet Information Software (FIS)
- Caterpillar Messenger

The tool then subtracts the recorded starting point from the current totals in the ECM in order to calculate the Fleet Trip Data. Resetting the Fleet Trip Data requires customer passwords if the passwords are programmed.

Maintenance Indicator Data

The ECM records the current totals when a reset occurs for the following three levels of maintenance:

- PM1
- PM2
- Cooling system clean/flush

The ECM uses the previous point of maintenance in order to calculate the timing of the next scheduled maintenance work.

The "Maintenance Indicator Mode" is programmable to hours or distance. The "PM1" maintenance is programmable to the "Off", "Automatic Distance", "Automatic Hours", "Manual Distance", or "Manual Hours" setting.

If the "PM1" is programmed to the "Automatic" mode, the ECM calculates the next point of maintenance by considering the history of the vehicle's operation from the previous maintenance interval. If the vehicle has a history of poor fuel economy the "Maintenance Indicator" parameter will occur sooner than a vehicle with better fuel economy.

The ECM also uses the engine oil capacity. A larger engine oil capacity provides a longer maintenance interval. The engine oil capacity is programmed into the ECM in liters or quarts. If the "PM1" is programmed to the "Manual" mode, the owner can program the ECM in the owner's specific maintenance interval. The maintenance interval can be programmed to the owner's specific interval that is based on mileage or time. The interval for the "PM2" and the interval for the cooling system clean/flush are established by the factory.

Caterpillar Messenger

The Caterpillar Messenger provides information on the engine operation. The "Maintenance Indicator" data may be viewed.

The CaterpillarMessenger provides the ability to enter an ID code for an operator in order to divide the information for two operators.

The CaterpillarMessenger may be used in order to tag portions of the operating information into two ID codes. The ID code and the information regarding the operation of the engine cannot be viewed from the display. Only the Caterpillar Fleet Information Software (FIS) can view this information. The ability to reset any of these parameters is dependent on customer parameters in the ECM.

The CaterpillarMessenger will display operating information such as engine rpm, coolant temperature, boost pressure, etc.

The CaterpillarMessenger will also display engine diagnostic codes with the PID-FMI Diagnostic Codes. The Caterpillar Messenger will also display a brief text description of the diagnostic codes.

An available feature of the Caterpillar Messenger is the Theft Deterrent. The Theft Deterrent allows the driver to input a password prior to shutdown. The Theft Deterrent will prevent the engine from restarting until the password is successfully entered. The CaterpillarMessenger must have the version of software that is capable of supporting this feature.

An "Auto-Enable" option is available as a Theft Deterrent on personality modules which are dated JUL99 and newer. If this option is selected, the Theft Deterrent feature will automatically be activated when the engine is shut down. The driver must input the correct password in order to start the engine.

Fleet Information Software (FIS) (JUL99 and Newer Personality Modules)

The Caterpillar Fleet Information Software (FIS) is another method that can be used to review engine operating information. Engine operating information, which includes the following elements of data may be accessed with Caterpillar FIS:

- Histograms
- Custom data
- Information that is tagged by the ID code

Maintenance indicator information can also be accessed by using the Caterpillar FIS.

When the Caterpillar FIS downloads the information, the Caterpillar FIS also resets the ECM in order to prepare the ECM for the next interval of engine operation. The information can be downloaded to a computer with the Caterpillar FIS program, or the information can be downloaded to an Argo Mobile Data Tool (MDT). The Argo Mobile Data Tool (MDT) is then connected to a computer in order to download the information.

Programmable Parameters

Certain parameters that affect the operation of the HEUI truck engine may be changed with the electronic service tool. The parameters are stored in the ECM, and the parameters are protected from unauthorized changes by passwords. These parameters are either system configuration parameters or customer parameters.

System configuration parameters are set at the factory. System configuration parameters affect emissions or power ratings within an engine family. Factory passwords must be obtained and factory passwords must be used to change the system configuration parameters.

Customer parameters are variable. Customer parameters can be used to affect the following characteristics of the engine within the limits that are set by the factory, Caterpillar Engine Monitoring, and PTO operation:

- Cruise control
- Vehicle speed limits
- Progressive shifting
- Rpm ratings
- Power ratings

Customer passwords may be required to change customer specified parameters.

Some of the parameters may affect engine operation in an unusual way. A driver might not expect this type of effect. Without adequate training, these parameters may lead to power complaints or performance complaints even though the engine's performance is to the specification.

Refer to Troubleshooting, "Customer Specified Parameters".

Passwords

System configuration parameters are protected by factory passwords. Factory passwords are calculated on a computer system that is available only to Caterpillar dealers. Since factory passwords contain alphabetic characters, only the electronic service tool may change system configuration parameters. System configuration parameters affect the power rating family or emissions.

Customer parameters are protected by customer passwords. The customer passwords are programmed by the customer. Factory passwords can be used to change customer passwords if customer passwords are lost.

Refer to Troubleshooting, "Customer Passwords" and Troubleshooting, "Factory Passwords".

i01632525

Glossary

SMCS Code: 1000

A/C High Pressure Switch – The a/c high pressure switch senses refrigerant pressure in the air conditioning system. The a/c high pressure switch opens the electrical contacts and/or the a/c high pressure switch closes the electrical contacts. The opening and/or closing of the electrical contacts depends on the pressure in the system in order to turn on the cooling fan. This switch may be connected to the ECM or this switch may not be connected to the ECM.

ATA Data Link (American Trucking Association) – The ATA data link is a two wire electrical connection for communication with other microprocessor based devices that are compatible with the American Trucking Association standards and SAE standards (J1587 and J1708) such as trip recorders, electronic dashboards, power train controls, and maintenance systems. The data link is also the serial communication medium that is used for programming and troubleshooting with Caterpillar devices.

Accelerator Pedal Position – The accelerator pedal position is the interpretation by the ECM of the signal from the accelerator pedal position sensor.

Accelerator Pedal Position Sensor – The accelerator pedal position sensor is an electronic sensor that is connected to the accelerator pedal. The accelerator pedal position sensor sends a pulse width modulated signal to the ECM.

Active Diagnostic Code – An active diagnostic code describes a condition that is currently present in order to alert the driver or the service technician of an abnormal parameter of engine operation. Refer to a Diagnostic Fault Code.

Aftermarket Device – An aftermarket device is a device or an accessory that is installed by the customer after the vehicle is delivered.

Air-To-Air Aftercooler – An air-to-air aftercooler is a device that is used on turbocharged engines in order to cool inlet air that has undergone compression. The inlet air is cooled after the inlet air passes through the turbocharger. The inlet air is passed through an aftercooler (heat exchanger) that uses ambient air for cooling. The inlet air that has been cooled advances to the inlet manifold.

Alternating Current (AC) – Alternating current is an electric current that reverses direction at a regular interval that is reoccurring.

American Wire Gauge (AWG) – AWG is a measure of the diameter of electrical wire. AWG is also a measure of the current carrying capacity of electrical wire. When the AWG number is smaller, the diameter of the wire is larger. When the AWG number is larger, the diameter of the wire is smaller.

Anti-Lock Brake System (ABS) – An ABS is a brake system that attempts to reduce a skid during brake operation. A power train electronic control can turn off the engine retarder, if necessary. Also, a power train electronic control can signal the engine ECM to deactivate the engine retarder.

Atmospheric Pressure Sensor – The atmospheric pressure sensor measures barometric pressure. The sensor sends a signal to the ECM. The signal is used in engine control and in engine operation.

Auxiliary Retarder Relay – The brakes' solenoids are driven by an OEM installed relay, which is driven by the ECM.

Before Top Center (BTC) – BTC is the 180 degrees of crankshaft rotation before the piston reaches the top center position in the normal direction of rotation.

Boost Pressure Sensor – The boost pressure sensor measures inlet manifold air pressure. The boost pressure sensor sends a signal to the ECM.

Bypass Circuit – A bypass circuit is a circuit that is used as a substitute circuit for an existing circuit. A bypass circuit is typically used as a test circuit.

Calibration – Calibration is an electronic adjustment of a sensor signal.

Camshaft Speed/Timing Sensor – This sensor provides a variable amplitude and PWM signal to the ECM. The ECM interprets this signal as the crankshaft position and the engine speed.

CAT Data Link – The data link is an electrical connection that is used to communicate with other microprocessor based devices. The microprocessor based devices are compatible with the proposed American Trucking Association and the SAE Standard. These devices include trip recorders, electronic dashboards, and maintenance systems. The data link is also the communication medium that is used for programming with the Caterpillar Electronic Technician (ET). The data link is also used for troubleshooting with ET .

Caterpillar Driver Information Display (CAT ID) – The Caterpillar Driver Information Display is a digital readout of the performance parameters of the vehicle and performance parameters that are monitored by the ECM.

Caterpillar Engine Monitoring – Caterpillar Engine Monitoring is the part of the Caterpillar electronic engine control that monitors coolant temperature, oil pressure, inlet manifold air temperature and coolant level. The monitoring alerts the operator of detected problems. Coolant temperature, intake manifold air temperature, and oil pressure sensors are supplied by Caterpillar and monitored by the ECM. The coolant level sensor is installed by the vehicle OEM but still monitored by the ECM. Aftermarket engine monitoring systems do not interface with the Caterpillar Electronic Engine Control.

Check Engine Lamp – The check engine lamp is sometimes referred to as the diagnostic lamp. The check engine lamp is used to alert the operator of the presence of an active event. The lamp then flashes a diagnostic code.

Clutch Pedal Position Switch – The switch is typically supplied and installed by the OEM. This switch is typically a limit switch that is mounted near the clutch pedal. The switch is usually adjustable. This switch is in the normally closed position when the clutch pedal is released. Depressing the clutch pedal will open the circuit.

Code – Refer to the Diagnostic Fault Code and the Diagnostic Event Code.

Cold Mode – Cold Mode is a mode for cold starting and for cold engine operation that includes timing that is retarded and low idle that is raised. This mode is used for engine protection, reduced smoke emissions and faster warm up time.

Coolant Level Sensor – This OEM installed sensor detects the absence or presence of coolant at the probe. The sensor then sends a signal to the ECM.

Coolant Temperature Sensor – This sensor detects the engine coolant temperature for Cold Mode operation and the Caterpillar Engine Monitoring. The Caterpillar Engine Monitoring must be programmed in the ON position for the coolant temperature sensor to be effective.

Cooling Fan Cab Override Switch – This switch overrides control of the cooling fan relay so the cooling fan operates continuously. This switch is supplied and installed by the OEM.

Cooling Fan Relay – This relay is controlled by the ECM which uses information from the coolant temperature sensor, the engine retarder and the air conditioning high pressure switch. The air conditioning high pressure switch is not always installed. The relay and the air conditioning high pressure switch is supplied and installed by the OEM.

Cruise Control Range – The cruise control range is the speed range that is monitored by the cruise control. This speed range is typically the anticipated speed range on the open road. The cruise control range is programmable by using the low cruise limit and the high cruise limit.

Custom Data – Custom data is part of the fleet trip data that is stored in the ECM. This capability allows the vehicle owner to specify operating parameters for monitoring purposes while the engine is in service.

Customer Specified Parameter – A customer specified parameter is a value that can be set and changed by the customer. The parameters can be protected by customer passwords.

Data Link – Refer to the ATA Data Link and J1939 Data Link.

Desired RPM – The desired rpm is input to the electronic governor within the ECM. The electronic governor uses the signal from the accelerator pedal position sensor, the engine speed sensor, the cruise control, and the customer parameters in order to determine desired rpm.

Diagnostic Event Code – These codes indicate an event that describes an abnormal engine condition such as an idle shutdown occurrence. These codes are not necessarily an indication of problems within the electronic system.

Diagnostic Fault Code – A diagnostic fault code is sometimes referred to as a fault code. These codes indicate an electronic system malfunction.

Diagnostic Flash Code – The diagnostic flash codes are flashed on the check engine lamp. These flash codes indicate a malfunction in the electronic system or an event that is detected by the ECM.

Diagnostic Lamp – A diagnostic lamp is sometimes called the check engine light. The diagnostic lamp is used to warn the operator of the presence of an active diagnostic code.

Direct Current (DC) – Direct current is the type of current that flows consistently in only one direction.

Dual Coil Vehicle Speed Sensor – The dual coil vehicle speed sensor is a magnetic pickup that senses movement of the teeth on the output shaft of the transmission. The sensor contains two coils. One of the coils supplies a signal to the vehicle speedometer, and the other coil is a vehicle speed buffer.

Duty Cycle – Refer to Pulse Width Modulation.

Electronic Control Analyzer Programmer (ECAP) – The ECAP is an electronic service tool that was replaced by the CAT Electronic Technician.

Electronic Engine Control – The electronic engine control is a complete electronic system. The electronic engine control monitors the engine operation under all conditions. The electronic engine control also controls the engine operation under all conditions.

Electronic Technician (CAT ET) – The ET is a service tool that uses a software program in order to run on a personal computer (PC). This program replaced the ECAP tool.

Engine Control Module (ECM) – The ECM is the engine's control computer. The ECM provides power to the electronics. The ECM monitors data that is input from the engine's sensors. The ECM acts as a governor in order to control engine rpm.

Estimated Dynamic Timing – The estimated dynamic timing is the estimate that is provided by the ECM of the actual injection timing.

Exhaust Brake Relay – The brake solenoids are driven by an OEM installed relay, which is driven by the ECM.

Failure Mode Identifier (FMI) – This identifier indicates the type of failure that has been experienced by the component. The FMI has been adopted from the SAE practice of J1587 diagnostics. The descriptions for the diagnostic codes are shown in the following list:

- 0 The data is valid but the data is above the normal operational range
- 1 The data is valid but the data is below the normal operational range

- 2 The data is erratic, intermittent, or incorrect.
- 3 The voltage is above normal or the voltage is shorted high
- 4 The voltage is below normal or the voltage is shorted low
- 5 The current is below normal or the circuit is open
- 6 The current is above normal or the circuit is grounded
- 7 The mechanical system is not responding properly
- 8 Abnormal frequency, pulse width, or period
- 9 Abnormal update
- 10 Abnormal rate of change
- 11 The failure mode is not identifiable
- 12 Damaged device or component
- 13 The device or the component is not calibrated
- 14 and 15 These locations are reserved for a future assignment

Flash Code (FC) – The flash codes are proprietary Caterpillar code numbers that are flashed on the diagnostic lamp.

Flash Programming – Flash programming is the method of programming or updating an ECM with ET over the data link instead of replacing components.

Fleet Information Software (FIS) – FIS is a software program that operates on a PC. This program allows the user to review the trip information. The program also allows the user to reset the trip information which includes the "Maintenance Indicator" information.

Fuel Position – This is an internal signal within the ECM. The signal comes from the electronic governor and the signal then goes to the fuel injection control. The information that is gathered is based on the desired rpm, the FRC limit, the rated fuel limit, and the actual engine rpm.

Fuel Ratio Control (FRC) – The FRC is a limit that is based on the control of the fuel to air ratio. The FRC is used for purposes of emission control. When the ECM senses a higher boost pressure (more air into the cylinder), the FRC increases the FRC limit (more fuel into the cylinder).

Fuel Temperature Sensor – This sensor detects the fuel temperature. The ECM monitors the fuel temperature and the ECM adjusts the calculated fuel rate accordingly.

Full Load Setting (FLS) – The FLS is the number that represents the fuel system adjustment. This adjustment is made at the factory in order to help ensure the maximum fuel delivery of the fuel system. The correct value for this parameter is stamped on the engine information ratings plate. This parameter must be programmed. If the parameters are not programmed 253-02 Check Customer Parameters will be generated or 56 Check System Parameters will be generated.

Full Torque Setting (FTS) – The FTS is similar to the FLS. This parameter must be programmed. If the parameters are not programmed 253-02 Check Customer Parameters will be generated or 56 Check System Parameters will be generated.

Gear Down Protection – This feature consists of the high gear limits that are programmable. High gear limits are used in order to promote driving in higher gears for increased fuel economy.

Harness – The harness is the bundle of wiring (loom) that connects all components of the electronic system.

Hertz (Hz) – Hertz is the measure of electrical frequency in cycles per second.

High Pressure Oil Manifold – The high pressure oil manifold is an oil gallery that is added to the cylinder head in order to supply the unit injectors with high pressure oil.

High Pressure Oil Pump – The high pressure oil pump is an axial piston pump that is driven by gears. The high pressure oil pump is used to raise the engine oil pressure in order to activate the unit injectors. The amount of oil pressure that is required to activate the unit injectors is called the actuation pressure.

Histogram – The histogram is a bar graph which may indicate the relative frequency of vehicle operation in specific operating ranges. A histogram can be used to show many relationships.

Hydraulic Electronic Unit Injector (HEUI) – The unit injector is an injection pump which is a hydraulically actuated, electronically controlled unit injector. This unit combines the pumping, electronic fuel metering and injecting elements in a single unit.

Idle rpm Limit – This is a programmable parameter which indicates the maximum allowable engine rpm that is allowed when the engine rpm is set with the cruise set/resume switch.

Idle Shutdown Time – This programmable parameter indicates a designated idle time in minutes that is allowed before shutdown.

Idle/PTO Bump rpm – This programmable parameter indicates the amount of change to the engine rpm that will occur when the switch for acceleration is toggled or the switch for deceleration is toggled.

Injector Codes – The injector codes or injector trim codes are numeric codes or alphanumeric codes that are etched or stamped on individual injectors.

Injection Actuation Pressure Control Valve – This is a dump valve that is controlled by an electrical signal that maintains high pressure for the high pressure oil manifold. The ECM controls the pressure in the high pressure oil manifold by inputs from the other sensors. The control valve regulates the high pressure oil to the hydraulic electronic unit injector through the high pressure oil manifold. Proper fuel injection pressure is necessary for desired engine operation.

Injection Actuation Pressure Sensor – An electrical sensor on the high pressure oil manifold converts oil pressure into an electrical signal for the ECM.

Inlet Manifold Air Temperature Sensor – This sensor detects the air inlet temperature. The ECM monitors the inlet air temperature and other data in order to adjust injection timing and other performance functions.

Integrated Electronic Controls – The engine is designed with the electronic controls as a necessary part of the system. The engine will not operate without the electronic controls.

J1939 Data Link – This data link is an SAE diagnostic communications data link that is used to communicate between the electronic engine, the transmission, and/or the power train controls.

Kickout Switch – This term refers to the service brake switch and the clutch switch. These switches are used as an exit or a kickout for the cruise control set speed, the idle speed setting, or the PTO/idle set speed.

Latch Mode – This is a programmable parameter for control of the exhaust brake. The exhaust brake engages when the service brake pedal is depressed. The exhaust brake remains engaged until the control detects a change in a control input.

Logged Diagnostic Codes – Logged diagnostic codes are codes which are stored in memory. These codes are meant to be an indicator of possible causes for intermittent problems. Refer to the Diagnostic Fault Code for more information.

Oil Pressure Sensor – This sensor measures engine oil pressure and the sensor signals the ECM.

Open Circuit – An open circuit is a condition that is caused by an open switch, or an electrical wire or a connection is broken. When this condition exists, the signal or the supply voltage can no longer reach the intended destination.

Original Equipment Manufacturer (OEM) – The OEM is the manufacturer of a vehicle that uses a Caterpillar engine for the power source.

Parameter – A parameter is a value or a limit that is programmable. This helps determine specific characteristics or behaviors of the engine and/or vehicle.

Parameter Identifier (PID) – The PID is a two digit code or a three digit code which is assigned to each component in order to identify data via the data link to the ECM.

Passive Magnetic Speed Sensor (Vehicle) – This sensor is a vehicle speed sensor that does not require a power and a ground connection. The sensor produces a signal that is based on the change in magnetic flux of a ferrous metal gear near the sensing tip.

Password – A password is a group of numeric characters or a group of alphanumeric characters that is designed to restrict access to parameters. The electronic system requires correct passwords in order to change customer specified parameters (customer passwords) or certain engine specifications (factory passwords). Passwords are also required to clear certain diagnostic codes.

Pedal Mounted Accelerator Pedal Position Sensor – This sensor measures the position of the accelerator pedal and the sensor sends a signal to the ECM. The sensor is mounted on an accelerator pedal assembly.

Personality Module or Ratings Personality Module – This module is attached to the inside of the ECM. The module contains all the instructions (software) for the ECM and the module contains the performance maps for a specific horsepower family.

Power Take-Off (PTO) – The PTO operates with the cruise control switches and the dedicated PTO on/off switch. This mode permits the setting of constant engine speeds or the mode permits varying the speed with either the accelerator pedal in the cab or a remote accelerator.

Pro-Link – Pro-Link is an electronic service tool that is hand-held. The tool is manufactured by Micro Processor Systems, Inc. (MPSI). This tool is supplied with a Caterpillar cartridge in order to service a Caterpillar engine that is electronically controlled.

Progressive Shifting – This is a method of upshifting through the lower gears quickly and not using excessive engine rpm in each gear. Shifts are made above peak torque but below rated rpm. Using excessively high engine rpm ranges before shifting to the next gear wastes fuel. Using the excessively high engine rpm ranges also fails to take advantage of the torque rise of the engine. The two steps LoGr 1 and LoGr 2 give the opportunity for progressive shifting. LoGr 1 is typically set no lower than peak torque plus 200 rpm. LoGr 2 is typically set at a point that is midway between the LoGr 1 rpm limit and the top engine limit.

PTO Configuration – This is a programmable parameter that determines the best use of the ECM input and the ECM output for PTO applications.

Pulse Width Modulation (PWM) – The PWM is a signal that consists of pulses that are of variable width. These pulses occur at fixed intervals. The ratio of "time on" versus total "time off" can be varied. This ratio is also referred to as a duty cycle.

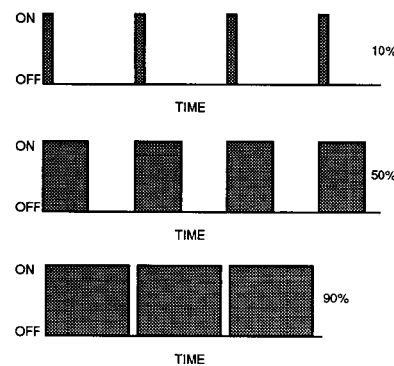

Illustration 7

g00284479

Rated Fuel Limit – This term indicates the maximum allowable fuel position (longest injection pulse). This position will produce rated power for this engine configuration.

Reference Voltage – The reference voltage is a regulated voltage and a steady voltage that is supplied by the ECM to a sensor. The reference voltage is used by the sensor to generate a signal voltage.

Remote Station Operation – This is a location that is outside of the vehicle cab. The functions such as the engine speed control are typically used for some type of PTO operation that is for pumping or for some other application that uses the engine power. These functions are controlled from the remote station.

Sensor – The sensor is a device that is used to detect a change in pressure, temperature, or mechanical movement. The information that is detected is converted into an electrical signal.

Service Brake Pedal Position Switch – This switch is typically a pressure switch that is supplied and installed by the OEM. This switch is normally closed when the brake pedal is in the released position. Depressing the brake will open the circuit.

Service Engine Soon Lamp – This is sometimes referred to as the diagnostic lamp. The Service Engine Soon Lamp is used to alert the operator of the presence of an active event by flashing a diagnostic code.

Service Program Module (SPM) – The service program module is a software program that is used to adapt the electronic service tool to a specific engine application.

Short Circuit – A short circuit is a condition that has an electrical circuit that is inadvertently connected to an undesirable point. An example of a short circuit is a wire which rubs against a vehicle frame and this rubbing eventually wears off the wire insulation. Electrical contact with the frame is made and a short circuit results.

Signal – The signal is a voltage or a waveform that is used in order to transmit information typically from a sensor to the ECM.

Speed Burp – A speed burp is a sudden, brief, unwanted change in the engine rpm.

Standard SAE Diagnostic Communications Data Link – Refer to the ATA Data Link.

Subsystem – A subsystem that is used in this application is a part of the electronic system that relates to a particular function. An example of a subsystem is the throttle subsystem.

Supply Voltage – The supply voltage is a constant voltage that is supplied to a component in order to provide electrical power that is required for the component to operate. The power may be generated by the ECM or the power may be battery voltage that is supplied by the vehicle wiring.

System Configuration Parameters – System configuration parameters are parameters that affect the power rating family or emissions.

T-Harness – The T-Harness is a test harness that is designed to connect into the vehicle harness or the engine harness. This connection allows a normal circuit operation and the connection simultaneously provides a breakout T in order to measure the signals.

Theft Deterrent – This feature uses a four digit code in order to prevent the engine from starting. The feature requires a password to be entered via the CAT ID.

Throttle Position – The ECM calculates the throttle position from the signal of the accelerator pedal position sensor. The throttle position may be used as part of a power take-off control.

Timing Calibration – The timing calibration is the adjustment of an electrical signal as a means of correcting the timing error between the crankshaft and the crankshaft position sensor.

Torque Limit – The torque limit is a programmable parameter which limits the maximum torque that is based on the programming of the parameter. An OEM installed torque limit switch is required.

Total Tattletale – The “Total Tattletale” is the total number of changes to all the customer specified parameters that are stored in the ECM.

Transducer – A transducer is a device that converts a mechanical signal to an electrical signal.

Transmission Style – The “Transmission Style” is a programmable parameter that designates the type of transmission in the vehicle and the various circuits that are connected to the ECM. The relay for the transmission, cruise control, PTO/idle set speed, and the operation of the exhaust brake are affected by this parameter setting.

Trip Recorder – The trip recorder is an after market device that is dedicated to recording the parameters of the vehicle and the parameters of the operating engine during the vehicle service. The trip recorder is used to analyze the driving habits and the recorder is used in order to produce the logs of the driver.

Vehicle Speed Calibration – The “Vehicle Speed Calibration” is a programmable parameter that is used by the ECM to convert the vehicle speed signal into miles per hour or kilometers per hour.

Vehicle Speed Sensor – The vehicle speed sensor is an electromagnetic pickup that measures vehicle speed from the rotation of gear teeth in the drive train of the vehicle.

i01850054

Electronic Service Tools

SMCS Code: 1900

The Caterpillar electronic service tools for the electronic control system are designed to help the service technician analyze faults or problems within the system. The Caterpillar electronic service tools are required to perform some sensor calibrations electronically. The Caterpillar electronic service tools are required to read engine parameters and the Caterpillar electronic service tools are required to change engine parameters. The Caterpillar Electronic Technician (Cat ET) requires a personal computer with the Cat ET software. Cat ET also requires a Caterpillar Communication Adapter.

There are several adapter cables, breakout T cables, probes, and other miscellaneous items that are used in order to access measurements of signals. A heavy duty multimeter is suitable in order to make the necessary measurements. A multimeter that has the ability to measure the Duty Cycle may also be required. Special tools that are used to measure pressure and temperature may be needed.

Required Service Tools

Table 1

Part Number	Description
5P-7277	Voltage Tester (Test Lamp)
9U-5103	Socket (Coolant Temperature Sensor Removal)
6V-2197	Magnetic Transducer (Timing Calibration Probe)
7X-1171	Transducer Adapter (Timing Probe Adapter)
7X-1695	Cable (Timing Probe Cable)
1U-5804	Crimp Tool
1U-5805	Wire Removal Tool (14 AWG Wire)
151-6320	Wire Removal Tool (16 and 18 AWG Wire)
167-9225	Harness (Bypass for Service Tool)
140-2266	Harness (70-Terminal Breakout T for ECM)
6V-7070	Digital Multimeter
9U-7330	Digital Multimeter
146-4080	Digital Multimeter
212-2160	Digital Multimeter

Caterpillar Electronic Technician (Cat ET)

Cat ET can be used to display the following information:

- Programmable Parameter Settings
- Active Diagnostic Codes and Logged Diagnostic Codes
- Logged Events
- Engine Rating History
- Driver and Fleet Trip Segments
- Histograms
- Custom Data
- ECM Date/Time Clock
- Maintenance Intervals

Cat ET can also be used to perform the following functions:

- Diagnostic Tests
- Sensor Calibrations
- Flash Programming
- Parameter Programming
- Copy Configuration for ECM Replacement
- Data Logging
- Real Time Graphing
- Snapshot Recorder

The following components are required to use Cat ET to service the engine.

Table 2

Required Electronic Service Tools for the Use of Cat ET	
Part Number	Description
	Caterpillar Electronic Technician
JERD2124	Single Use Program License
JERD2125 or JERD2128	Data Subscription (Truck Engine) Data Subscription (Truck and Commercial Engine)
JERD2129	"Data Subscription for All Engines and Machines"
171 - 4400 ⁽¹⁾	Communication Adapter II Gp

⁽¹⁾ The 7X - 1700 Communication Adapter Gp may also be used.

Connecting Cat ET and the Communication Adapter II

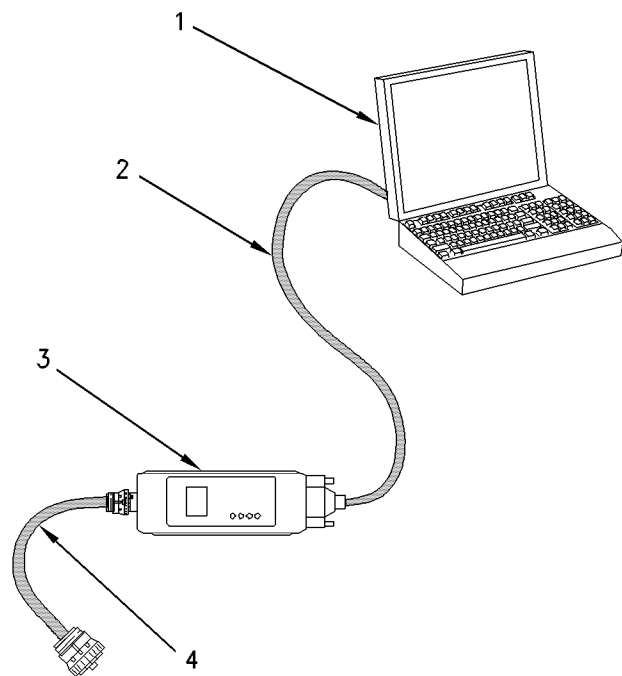

Illustration 8

g00647144

- (1) Personal computer (PC)
- (2) 196 - 0055 Adapter Cable As (PC Serial)
- (3) 171 - 4401 Communication Adapter II
- (4) 207 - 6845 Adapter Cable (Data Link)

Note: Items (2), (3), and (4) are part of the 171 - 4400 Communication Adapter II Gp.

Use the following procedure to connect Cat ET and the Communication Adapter II.

1. Turn the keyswitch to the OFF/RESET position. If the keyswitch is not placed in the OFF/RESET position, the engine may start.
2. Connect cable (2) between the "COMPUTER" end of communication adapter (3) and the RS232 serial port of PC (1).
3. Connect cable (4) between the "DATA LINK" end of communication adapter (3) and the service tool connector.
4. Turn the keyswitch to the ON position. If Cat ET and the communication adapter do not communicate with the ECM, refer to Troubleshooting, "Electronic Service Tool Will Not Communicate With ECM".

Optional Service Tools

Table 3

Part Number	Description
190 - 8900	Connector Repair Kit ⁽¹⁾
7X - 6370	Adapter Cable (3 Pin DT Breakout T)
8T - 8726	Adapter Cable (3 Pin HD Breakout T)
7X - 1710	Multimeter Probe (Spoons)
1U - 5718	Vacuum Pump
1U - 8757	Tube (Attachment for Vacuum Pump)
169 - 7372	Bottle Assembly (Vacuum Pump)
9S - 9082	Engine Turning Tool
1U - 5470	Engine Pressure Group
6V - 9130	Temperature Adapter
124 - 5643	Cable (3 Pin Packard Breakout T)
125 - 3662	Cable (3 Pin DT Bypass T)
157 - 4829	Cable Adapter (9 Pin J1939 Dash)
7X - 1403	Adapter Cable (9 Pin Navistar Dash)
7X - 1686	Cable Adapter (6 Pin Dash)
139 - 4166	Data Link Cable As (Communication Adapter to Dash Connector)
139 - 4166	Adapter Cable (9 Pin Service Tool Breakout T)

⁽¹⁾ This kit includes a 1U - 5804 Crimp Tool.

i01584339

Sensors and Electrical Connectors

SMCS Code: 1900-035

(Table 4, contd)

J501/P501	Air Inlet Heater Relay (2-Pin Connector)
J648/P648	Air Inlet Heater Lamp (2-Pin Connector)

Table 4

Connector	Function
J1/P1	ECM Connector (70-Pin OEM Harness)
J2/P2	ECM Connector (70-Pin Engine Harness)
J100/P100	Coolant Temperature Sensor (2-Pin Connector)
J103/P103	Inlet Manifold Air Temperature Sensor (2-Pin Connector)
J200/P200	Boost Pressure Sensor (3-Pin Connector)
J201/P201	Engine Oil Pressure Sensor (3-Pin Connector)
J203/P203	Atmospheric Pressure Sensor (3-Pin Connector)
J204/P204	Injection Actuation Pressure Sensor (3-Pin Connector)
J300/P300	Injector Solenoid Harness (12-Pin Connector)
J301/P301	Injector Solenoid for Cylinder number 1 (2-Pin Connector)
J302/P302	Injector Solenoid for Cylinder number 2 (2-Pin Connector)
J303/P303	Injector Solenoid for Cylinder number 3 (2-Pin Connector)
J304/P304	Injector Solenoid for Cylinder number 4 (2-Pin Connector)
J305/P305	Injector Solenoid for Cylinder number 5 (2-Pin Connector)
J306/P306	Injector Solenoid for Cylinder number 6 (2-Pin Connector)
J400/P400	Engine Timing Calibration Probe (2-Pin Connector)
J401/P401	Top Camshaft Speed/Timing Sensor (2-Pin Connector)
J402/P402	Bottom Camshaft Speed/Timing Sensor (2-Pin Connector)
J403/P403	Accelerator Pedal Position Sensor (3-Pin Connector)
J500/P500	Injection Actuation Pressure Control Valve (2-Pin Connector)

(continued)

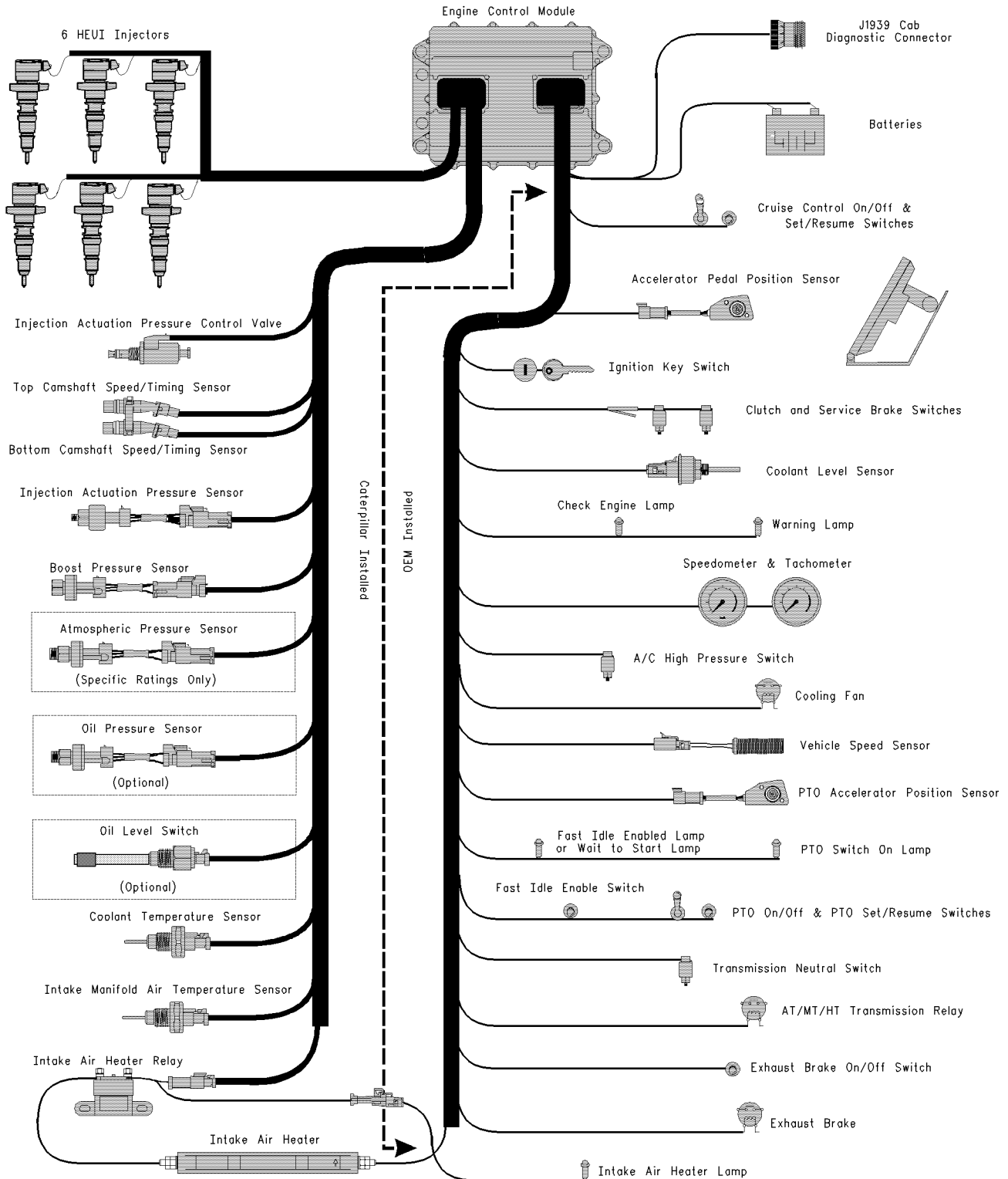

Illustration 9

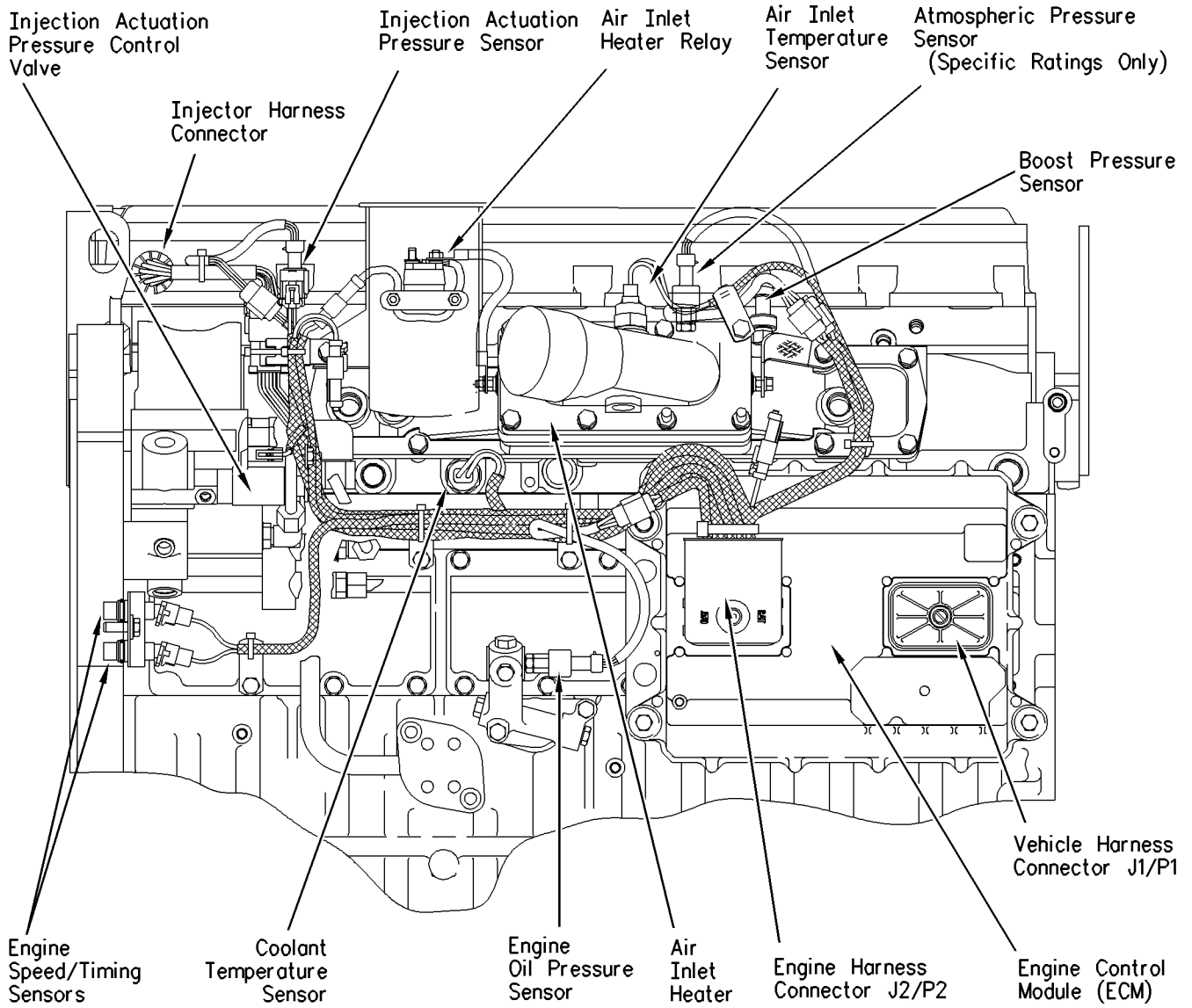

Illustration 10
Left side engine view

g00754879

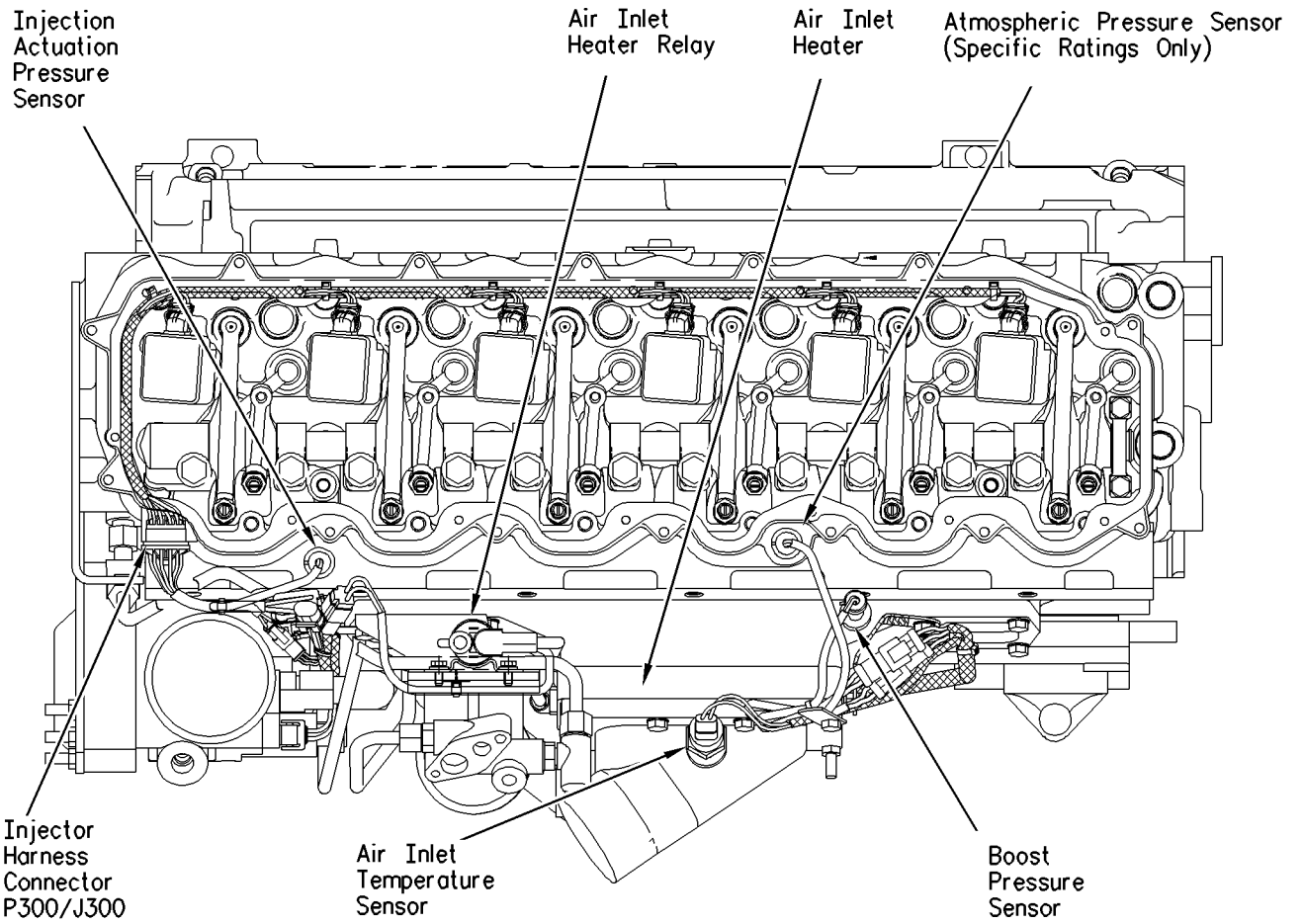

Illustration 11
Top engine view

g00754881

Engine Wiring Harness Diagram

SMCS Code: 1408-035

101585208

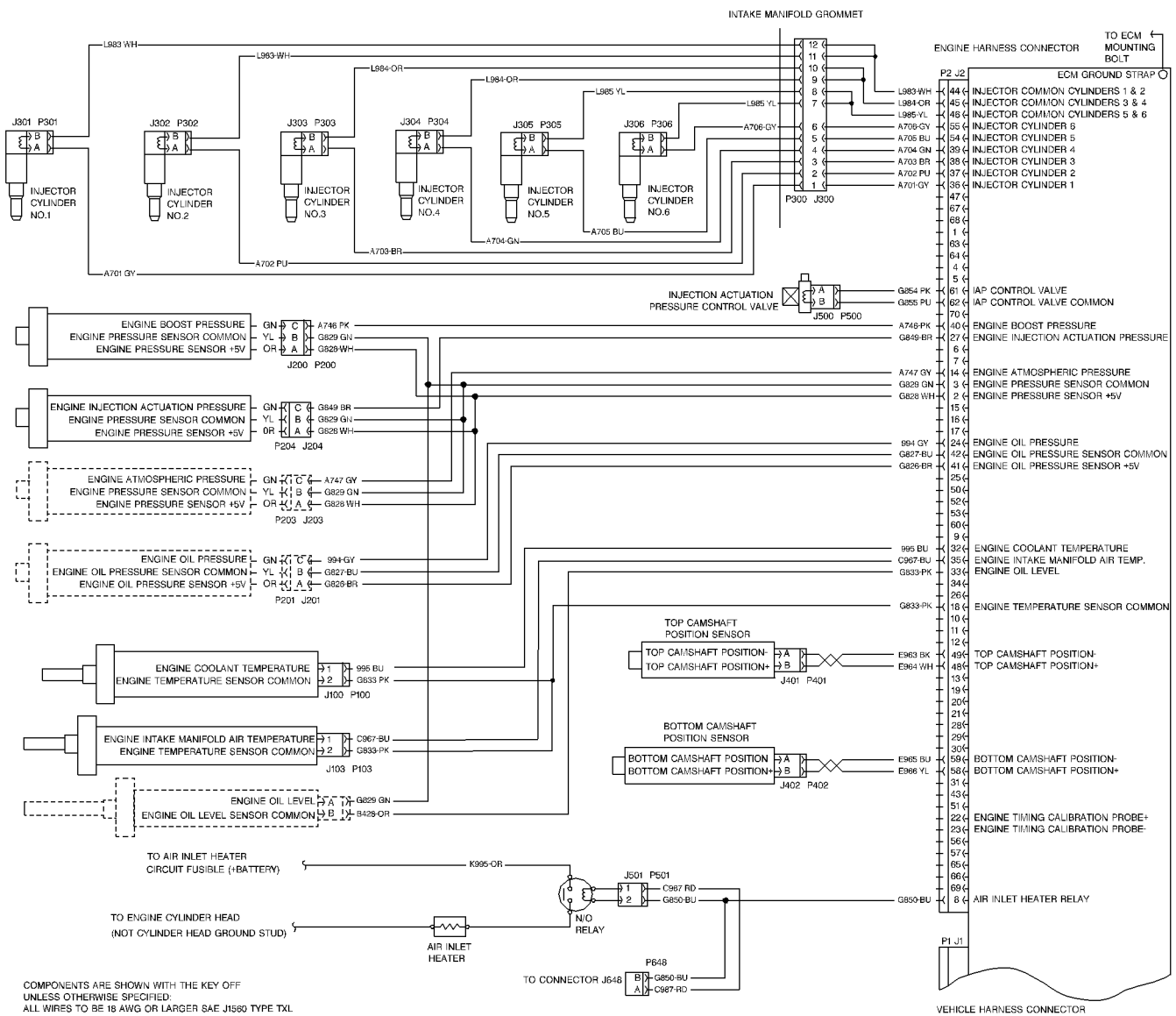

COMPONENTS ARE SHOWN WITH THE KEY OFF
UNLESS OTHERWISE SPECIFIED.
ALL WIRES TO BE 18 AWG OR LARGER SAE J1580 TYPE TXL
OR EQUIVALENT FOR TWISTED PAIR SPECIFICATION SEE
SAE J1708

NOTE A: DASHED LINES INDICATE AN OPTIONAL
COMPONENT NOT INSTALLED ON ALL ENGINES

Illustration 12

900822505

Programming Parameters

i01585627

Programming Parameters

SMCS Code: 1900

Many programmable parameters affect the engine operation. These parameters may be changed by using ET. The parameters are stored in the ECM. The parameters are not stored in the personality module. Any parameter can be read. However, passwords protect parameters from unauthorized changes.

Two categories contain various parameters, System Configuration Parameters and Customer Specified Parameters. System Configuration Parameters can be altered only with the proper factory passwords by using the Caterpillar Electronic Technician (ET).

Customer Specified Parameters can be changed by using ET only with the proper customer passwords. Refer to Troubleshooting, "Customer Passwords" and Troubleshooting, "Factory Passwords" for additional information.

Programming a New ECM

The Engine Control Module or the ECM is the brain of the system. So when a problem occurs, it is easy to assume that the ECM is responsible. This is usually the wrong assumption. Most failures occur at the wiring and connectors or at a sensor input or sensor output. Follow the procedures in the troubleshooting guide, and do not replace an ECM on an assumption. However, when your troubleshooting indicates that a failure has in fact occurred in the ECM, use the following procedure to replace a faulty ECM.

Note: If a replacement for the ECM is required, the customer parameters and the timing calibration can be transferred from the suspect ECM to the replacement ECM. Timing calibration will not be necessary. This feature requires the Caterpillar Electronic Technician (ET) and this feature is only possible if the suspect ECM can communicate with ET.

Test ECM Mode

Test ECM Mode is a feature in the software that can be used to help troubleshoot an engine that may have a problem with the ECM. This feature allows a standard ECM to be used as a test ECM. Using an ECM that has this capability eliminates the need to stock a test ECM. Test ECM Mode is available with engine software that is dated APR01 and later.

Use ET to start the Test ECM Mode. Access the feature through the "Service" menu. ET will display the status of the test ECM and the hours that are remaining for the Test ECM Mode.

Test ECM Mode can only be activated if the engine serial number has not already been programmed during normal operation of the ECM. If the engine serial number is programmed and the ECM is not in Test ECM Mode, the ECM can never be used as a test ECM.

While the ECM is in Test ECM Mode, the ECM can be programmed to meet the needs of the application. This is accomplished by copying the original configuration of the ECM to the test ECM.

When the Test ECM Mode is activated, an internal timer sets a 24 hour clock. This clock will count down only while the ECM is powered and the key switch is in the ON position. After the ECM has counted down the 24 hour period, the ECM will exit the Test ECM Mode. The parameters, the accumulated mileage, and the engine serial number will be set.

Once an ECM has been activated in the Test ECM Mode, the ECM will stay in the Test ECM Mode until the timer times out. If the ECM is used as a test ECM for more than one engine, the Test ECM Mode must be reactivated. Anytime prior to the Test ECM Mode timing out, the ECM can be reset to 24 hours.

Replacing the ECM with the Use of the ECM Replacement Feature from Caterpillar Electronic Technician (ET)

1. Ensure that the ECM is the problem by first connecting a test ECM. This is a temporary connection. Hang the test ECM on the side of the engine. Flash program the identical Personality Module that was used in the suspect ECM into the test ECM. Use the ECM Replacement Feature in ET to copy the parameters from the ECM that is suspect. Copy these parameters into the test ECM. Ensure that the parameters in the test ECM are equal to the parameters in the suspect ECM.
2. If the test ECM repairs the problem, reconnect the suspect ECM. Verify that the problem returns when the suspect ECM is reconnected.
3. Select the ECM Replacement Feature under the "Service/Copy Configuration" menu and load the parameters from the failed ECM.
4. Temporarily connect the new ECM by connecting both ECM connectors. Do not mount the ECM on the engine yet.

5. Flash program the Personality Module into the new ECM if the personality module is not already installed. The new ECM is shipped with a blank Personality Module.
6. Use the ECM replacement feature in ET to program the new ECM.
7. Enter the value for the "Rating Number" parameter into the new ECM.
8. Check for active codes. Program any required parameters that have not been programmed.

Note: On initial powerup of a new ECM, the parameter "Rating Number" must be programmed to avoid activating a 253-02 Check Customer Or System Parameters (56).

9. If 22-13 Check Timing Sensor Calibration is not active, install the new ECM on the engine. Otherwise, perform a timing calibration first.

Replacing the ECM without the Use of the ECM Replacement Feature from Caterpillar Electronic Technician (ET)

1. Ensure that the ECM is the problem by first connecting a test ECM. This is a temporary connection. Hang the test ECM on the side of the engine. Flash program the identical Personality Module that was used in the suspect ECM into the test ECM. Program any parameters that are necessary to use the ECM for the test. For example, Vehicle speed parameters need to be programmed to check the vehicle speed circuit. Program the parameters in the test ECM to be equal to the parameters in the suspect ECM.
2. If the test ECM repairs the problem, reconnect the suspect ECM. Verify that the problem returns when the suspect ECM is reconnected.
3. Obtain customer parameters from the failed ECM.
 - a. Obtain the Customer Passwords and record the Customer Passwords. If the customer (owner) has lost the passwords or if the customer (owner) has forgotten the passwords, proceed to Troubleshooting, "Customer Passwords" for more details.
 - b. Use ET to access Customer Specified Parameters from the ECM that is being replaced. If the ECM does not communicate with ET, obtain the required parameter list from the OEM.

- c. Use the Troubleshooting, "Customer Specified Parameters Worksheet" to record the customer parameters.

4. Record ECM lifetime totals.

- a. Use the Troubleshooting, "Customer Specified Parameters Worksheet (Current Totals Worksheet)" to record the old ECM Current Totals.

5. Temporarily connect the new ECM by connecting both ECM connectors. Do not mount the ECM to the engine until the timing calibration has been performed.

6. Flash program the Personality Module into the new ECM if the Personality Module is not already installed. The new ECM is shipped with a blank Personality Module.

7. Obtain the factory passwords when the passwords are required.

Note: The following parameters can be programmed on a new ECM without factory passwords: "Full Load Setting (FLS)", "Full Torque Setting (FTS)", and "Engine Serial Number". System Configuration parameters must be entered before the Customer Specified Parameters are entered. If Customer Parameters are entered before the System Configuration Parameters, the Total Tattletale will change. It will then be necessary to obtain another set of factory passwords in order to access System Configuration Parameters.

8. Perform the following operations.

- a. Use the Troubleshooting, "Factory Passwords Worksheet" to record the following information from the engine information plate: "Full Load Setting (FLS)", "Full Torque Setting (FTS)", and "Engine Serial Number".

- b. Record the mileage from the vehicle odometer. Use ET to access System Configuration Parameters. When the screen for the "Factory Specified Passwords" appears, record the following information: "ECM Serial Number", "Engine Serial Number", "ET Serial Number", "Total Tattletale", and "Reason Code".

- c. Leave ET on the screen for the "Factory Specified Passwords" and obtain the factory passwords. Complete the Troubleshooting, "Factory Passwords Worksheet".

9. Program the new ECM.

Note: On initial powerup of a new ECM, the following parameters must be programmed to avoid activating 253-02 Check Customer Or System Parameters (56): "Full Load Setting (FLS)", "Full Torque Setting (FTS)", "Vehicle Speed Calibration" (ppm), "Rating Number", and "Engine Serial Number".

- a. Use ET to access System Configuration Parameters. Enter the following parameters that are recorded on the worksheet: "Full Load Setting (FLS)", "Full Torque Setting (FTS)", and "Engine Serial Number".
 - b. Use ET to access Customer Specified Parameters. Enter the Customer Specified Parameters and the original Customer Passwords that are recorded on the worksheet.
 - c. Use ET to access Current Totals from the Read/Change Current Totals main menu. Record the information by using the Troubleshooting, "Factory Passwords Worksheet" to obtain the factory passwords. Enter the totals from the original ECM that are recorded on the worksheet.
 - d. Select the following screens in order to calibrate the engine timing: "Service", "Calibrations", and "Timing Calibration". Calibrate the timing. Refer to Troubleshooting, "Engine Speed/Timing Circuit - Test".
10. Install the new ECM on the engine.

i01330282

Customer Passwords

SMCS Code: 1901

If Customer passwords have been entered, then the customer passwords are required to change ANY customer parameter. Customer parameters are those parameters that affect the vehicle speed limits, the power rating within an engine family and the PTO operation. Refer to Troubleshooting, "Customer Specified Parameters" for more detail on parameters that are customer programmable.

An ET or a MPSI Pro-Link with the Caterpillar cartridge may change customer parameters. To obtain customer passwords, contact the owner of the vehicle. If the owner has lost the owner's passwords, customer passwords may be read by using an ET.

Note: Factory passwords are required in order to read customer passwords.

Use the following procedure in order to read customer passwords with an ET:

1. Use the ET to access the Utilities Menu. Then access View Passwords under the Utilities Menu.
2. When the Factory Password screen appears, record the information that is listed on the Factory Passwords Worksheet. Refer to Troubleshooting, "Factory Passwords Worksheet".
3. Obtain the factory passwords. The information that is recorded on the Factory Passwords Worksheet must be provided. When the factory passwords are obtained, a permanent record of the access is generated at Caterpillar.
4. From the Factory Password screen, enter the factory passwords.
5. When the Read Customer Passwords screen appears, record the customer passwords. The customer passwords may then be used to change customer parameters.

i01641423

ECM Date/Time Stamped Information

SMCS Code: 1901

The date/time clock indicates the month, the day, the year and the time of day. This clock is used to time stamp the following diagnostic event codes:

- 84-00 Vehicle Overspeed Warning
- 110-11 Very High Coolant Temperature
- 111-11 Very Low Coolant Level
- 190-00 Engine Overspeed Warning

The following types of ECM data are also time stamped information:

- Diagnostic snapshots
- Snapshots that are triggered by using the set/resume switch
- Quick Stop snapshots

Adjustment of ECM Date/Time Clock

Before adjusting the ECM Date/Time Clock on a vehicle, ask the owner/operator if the time stamped information should be recorded. After the time stamped information is recorded, clear this information before adjusting the ECM Date/Time Clock. This is a very important step if the adjustment of the clock is a big adjustment. This will prevent unnecessary confusion if someone else views the information at a later date.

Occurrence of Time Stamped Information

When the time stamped information is being viewed, remember that the vehicle may be based in a different time zone. Also remember the following two possibilities:

- Someone may have incorrectly set the clock.
- No one ever set the clock.

Compare the electronic control module's current time of day to the time stamped information in the ECM in order to determine the amount of time that has passed since the occurrence of the time stamped event. **DO NOT REPLACE AN ECM BECAUSE OF AN INCORRECT TIME OF DAY.** The following example indicates the proper use of the clock.

Proper Use of ECM Date/Time Stamped Information

Caterpillar Electronic Technician (ET) indicates that a diagnostic code occurred. The 190-00 Engine Overspeed Warning occurred on 19 November 1998 at 10:30:46. ET also indicates that the current time of day in the ECM is 24 November 1998 at 11:20:58. **This indicates that the problem occurred in the past (approximately one week and 50 minutes).**

Do not compare the electronic control module's time of day to the current time of day at your location. If the electronic control module's time of day differs significantly from the current time of day (wrong month), ensure that the important time stamped information is recorded. After recording the information, clear the code or the snapshot, and then adjust the clock.

ECM Diagnostic Clock

The diagnostic clock should not be confused with the ECM Date/Time clock. The diagnostic clock records the actual hours of the ECM under power. The information from the diagnostic clock is used in order to log occurrences of diagnostic codes and occurrences of event codes. Logged diagnostic codes and logged event codes display the diagnostic clock hour of the first occurrence and the last occurrence and the total number of occurrences. The diagnostic clock does not represent actual engine hours. The clock increments any time of the ECM under power. This happens when the engine is running or when the engine is not running. Actual engine running hours (Total Time) can be obtained from the menu for Current Totals of Electronic Technician (ET).

i01642339

ECM Snapshot

SMCS Code: 1901

The ECM can record a snapshot of the engine parameters and vehicle parameters. The snapshot records the parameters for a period of 13 seconds that surrounds the event. The event is either a diagnostic code or an external trigger.

Use Of Snapshot

Use snapshots **ONLY** to help determine engine/vehicle operating conditions when an intermittent problem occurs. If an intermittent diagnostic code is causing problems, use the snapshot data. Snapshot data can be used to determine whether the problem seems to occur under specific circumstances. The following list of conditions is an example of some of the specific circumstances:

- Engine rpm
- Ranges of vehicle speed
- Ranges of coolant temperature

Use this data to attempt to duplicate these conditions with the vehicle and get the code to reoccur.

Replacement of electronic components should not be based on the snapshot data alone. When the snapshot information is triggered externally, the snapshot information is stored in frames during every 0.24 seconds. When the snapshot information is triggered by a diagnostic code, the snapshot information is stored in frames during every 0.48 seconds. Frequently, the parameters are changing at a rate that is different from 0.24 seconds. If too much emphasis is put on this information, the result could be a misdiagnosed problem. Also when snapshot information that is triggered by a diagnostic code is being viewed, the ECM sets a sensor value with an active diagnostic code to a default value when the code is active. This is the reason that the sensor value suddenly jumps to a specific value at the trigger point and the sensor value remains there for the rest of the snapshot frames. DO NOT attempt to interpret the information and DO NOT attempt to analyze the reason that the engine is operating from this historical information. Incorrect diagnoses will occur by looking at this information under a microscope. Incorrect diagnoses will occur because some of the parameters will not be set to the values that are expected. Even though the parameters are not related to the problem that is under investigation, the parameters can lead to incorrect diagnoses.

Snapshot Information that is Triggered by a Diagnostic Code

When a diagnostic code occurs the ECM records many of the status parameters that are available on the Caterpillar ET. The ECM records this information for approximately 9 seconds before the code occurs, and approximately 4 seconds after the code.

Snapshot Information that Is Triggered Externally

A snapshot can be triggered externally by using either the cruise control set/resume switch, or Caterpillar Electronic Technician (ET). Use the following procedure in order to trigger the snapshot by using the cruise control set/resume switch:

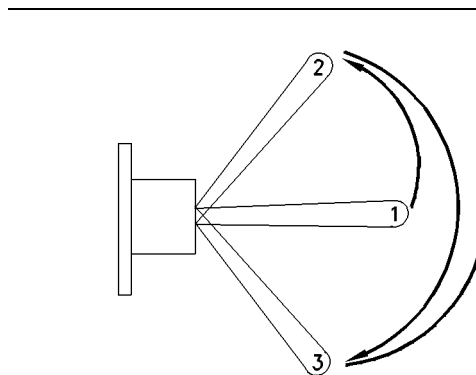

Illustration 13

g00627693

- (1) OFF position
- (2) SET position
- (3) RESUME position

1. Toggle the switch quickly from the OFF position (1) to the SET position (2).
2. Toggle the switch quickly from the SET position (2) to the RESUME position (3).
3. Toggle the switch quickly from the RESUME position (3) back to the OFF position (1).

Note: The switch must be toggled within a one second time period in order to take a snapshot of the engine parameters. The procedure can also be performed in the reverse order.

The snapshot can be triggered from the Snapshot Recorder Tool in ET. Refer to the instructions on the screen or the system's documentation for help.

Quick Stop Snapshot

A snapshot can also be stored for a quick stop event if the customer parameter is programmed. The ECM stores the number of occurrences of the Quick Stop Event and a snapshot of the latest occurrence.

One data record is kept for the most recent quick stop event. The previous record is replaced by the most recent record.

Each quick stop record contains 60 frames of information. Frame 45 is the quick stop event. The record contains 44 frames before the quick stop event and 15 frames following the quick stop event. Each frame is separated by 1.0 second. Each frame of the quick stop record stores the following data:

- Engine rpm
- Throttle position
- Clutch switch

- Vehicle speed
- Cruise status
- Brake switch

Storage of Snapshots in the ECM

The ECM can store a maximum of two snapshots that are triggered by a diagnostic code, two snapshots that are triggered externally, and one quick stop snapshot. The snapshots are stored in a circular buffer. The newest snapshot will replace the oldest snapshot.

The ECM stores the snapshots in memory. The memory is maintained through the unswitched battery connections. If the unswitched + battery pins are disconnected, or if the vehicle batteries are disconnected, the snapshot information is maintained by the internal battery in the ECM .

Also, the snapshots can be cleared manually by using ET. Snapshots are automatically cleared by the ECM after 100 hours of operation. Snapshots are similar to diagnostic codes in this characteristic.

i01443147

Factory Passwords

SMCS Code: 1901

Factory passwords are required to perform each of the following six functions:

1. Program a New ECM.

When an ECM is replaced, the System Configuration Parameters must be programmed into the new ECM. A new ECM will allow these parameters to be programmed once without Factory Passwords. After the initial programming, these parameters are protected by factory passwords.

2. Rerate to Another Engine Family

This requires changing the Personality Module Code, which is protected by factory passwords. This includes changing from a non-multitorque personality module to a multitorque personality module.

3. Read Customer Passwords

If the owner loses the owner's customer passwords, the owner will not be able to program customer parameters. By Using factory passwords, one can read customer passwords. Then use those customer passwords to program customer parameters.

4. Clear Certain Diagnostic Codes

The Diagnostic Code 190-00 that is Engine Overspeed Warning requires the use of factory passwords in order to clear the code once the code has been logged. The Diagnostic Code 252-11 that is Incorrect Engine Software (59) requires factory passwords. This diagnostic code should be cleared only when you are certain that the personality module is for the specific engine.

5. Unlock a Customer Parameter That is Locked.

If a Customer Parameter has been locked out, Factory Passwords are required to unlock the parameter. Also if a Customer Parameter has been locked out, Factory Passwords are required to change the parameter. Refer to Troubleshooting, "Customer Specified Parameters" for additional information.

NOTICE

Operating the engine with a Personality Module not designed for that engine will damage the engine. Be sure the Personality Module is correct for your engine.

Certain other codes require customer passwords. The majority of logged codes do not require passwords to be cleared. Since the factory passwords contain alphabetic characters, the Electronic Technician (ET) may perform these functions. In order to obtain the factory passwords, proceed as if you already have the password. At some point, if the factory passwords are actually needed, the Electronic Technician (ET) will request the factory passwords and the Electronic Technician (ET) will display the information that is required to obtain the passwords.

Note: The "Customer Parameter Lockout" may restrict changing some Customer Parameters unless Factory Passwords are obtained. If changing a Customer Parameter indicates that the Factory Passwords are required, the Parameter has been Locked Out. Refer to Troubleshooting, "Customer Specified Parameters" for additional information.

i01180795

Factory Passwords Worksheet

SMCS Code: 1901

Note: A mistake in recording these parameters will result in incorrect passwords.

Table 5

Dealer Code	
Customer's Name	
Address	
Telephone Number	
Information From Engine Information Plate	
Engine Serial Number	
Full Load Setting	
Full Torque Setting	
Information From Vehicle Odometer	
Engine's Miles (km)	
Information From Factory Password Entry Screen on ET	
Electronic Service Tool Serial Number	
Engine Serial Number	
ECM Serial Number	
Total Tattletale	
Reason Code	
From Interlock ⁽¹⁾	
To Interlock ⁽¹⁾	
Factory Passwords	
Factory Password (No. 1)	
Factory Password (No. 2)	

⁽¹⁾ This parameter is required when the engine is being rerated. This parameter is only displayed when the engine is being rerated.

i01330008

Flash Programming

SMCS Code: 1901

1. Connect the components. Refer to Troubleshooting, "Electronic Technician (ET)".

2. Start the WinFlash PC Program.

3. Ensure that the ignition key switch is ON and ensure that the engine is off.

4. Select the part number of the engine personality module that needs to be programmed into the ECM. Program the personality module. A new ECM is shipped with a blank personality module.

Note: The WinFlash PC Program provides the part number of the selected file for the ECM, the application and the software. Ensure that this file matches the engine before you begin to flash the file into the ECM.

5. Messages from the personality module and the meaning of the messages

A new ECM comes with a blank personality module. A blank personality module has not been programmed. A blank personality module will prompt you for all three of the following messages. The information that is contained in the ECM Status will be scrambled if the module has not been programmed previously. This is normal.

a. Message The engine ID in the flash file does not match the engine ID in the ECM.

b. Meaning The ECM has a personality module for a different engine.

c. Solution Stop the transfer of files. Access information about the ECM status under the menu for the ECM. Ensure that the file that was being transferred matches the engine application.

d. Message The application ID in the flash file does not match the application ID in the ECM.

e. Meaning The ECM has a personality module for a different application. For example, the ECM has a personality module for a 3126B HEUI On-Highway truck engine and you are attempting to program a personality module for a 3508B Marine engine.

f. Solution Stop the transfer of files. Access information about the ECM status under the menu for the ECM. Ensure that the file that was being transferred is for a personality module for an On-Highway truck.

g. Message The ID of the ECM in the flash file does not match the ID of the ECM in the ECM.

h. Meaning The ECM is not for use with an On-Highway truck application.

- i. **Solution** Stop the transfer of files. Access information about the ECM Status under the menu for the ECM. Ensure that the ECM on the engine is for an On-Highway truck application.

Note: The amount of time that is required to flash a personality module is significantly longer than earlier applications. The amount of time that is required to flash a personality module with a 7X-1700 Communication Adapter is approximately ten minutes or more. The amount of time that is required to flash a personality module with a MPSI Pro-link with the Caterpillar cartridge as a communications adapter is approximately 20 minutes or more.

Note: If you access the ECM status under the menu for the ECM, but you do not program the personality module, complete the following procedure. Before using the ET, turn the vehicle's ignition keyswitch to the OFF position, and then turn the vehicle's ignition keyswitch to the ON position. If the ignition keyswitch is not cycled after reading the ECM Status, the ECM will not communicate with your service tool or the ECM will not start. Cycling the ignition keyswitch is not necessary after the personality module has been programmed by using the WinFlash PC Program.

6. Start the engine and check for proper operation.
 - a. Program any parameters that were not previously in the old personality module if a 253-02 Check Customer Or System Parameters (56) diagnostic code is active. Read the diagnostic code from the ET Active Diagnostic Code screen in order to determine the parameter (parameters) that requires programming.
 - b. On initial powerup of a new ECM, six parameters must be programmed to avoid a 253-02 Check Customer Or System Parameters (56) Diagnostic Code: Full Load Setting (FLS), Full Torque Setting (FTS), Vehicle Speed Calibration (ppm), Rating Number, Engine Serial Number, and Injector Trim Codes. Refer to Troubleshooting, "Programming Parameters".

i01183143

Service Information Report

SMCS Code: 1000

After verifying the correct repair has been performed on the vehicle it is critical to provide brief, detailed information. This information helps Caterpillar better serve you and the Customer.

Recommendations

Customer's Complaint

Provide a copy of the Troubleshooting, "Driver Questionnaire". Include comments in as many categories as possible. The following information is of particular importance:

- Indicate whether the Check Engine Lamp was ON continuously or whether the Check Engine Lamp was ON intermittently.
- Indicate the symptoms of vehicle operation that are present.

Cause of Failure

Comments on the Cause of Failure should include the number of diagnostic codes that were logged. Comments should also indicate if the code was an Active Code. Indicate the source of the problem. Also indicate the method that was used to discover the problem. Examples of the methods that were used to discover the problem could be one of the following methods:

- A specific procedure in the manual was followed.
- A visual inspection indicated that wire abrasion on the engine harness existed.
- An engine dynamometer test indicated that the power was below the specification at 1700 rpm due to the loss of the no. 4 injector and an engine dynamometer test indicated that the power was below the specification at all engine speeds above 1700 rpm due to the loss of the no. 4 injector.

Be as specific as possible.

Repair Procedure

Comments on the Repair Procedure should include the following types of information:

- The wiring harness was repaired.
- The FLS was changed per the factory's instructions.

Customer Specified Parameters

i01726562

Customer Specified Parameters

SMCS Code: 1901

Customer Specified Parameters allow the vehicle owner to influence the operating technique of a driver. Some parameters may affect engine operation in a way that would not be expected by an inadequately trained driver. These parameters may lead to power or performance complaints even though the engine's performance is within the engine's specification.

Customer parameters may be changed repeatedly as a customer's operation changes or as new drivers are assigned to a truck. Customer passwords may be required to change these parameters.

The following information is a brief description of the Customer Specified Parameters. The following parameter values are included with the descriptions:

- Minimum
- Maximum
- Default

Note: Parameter values that are shown in bold text are programmed settings that disable the feature.

The tables show values in an approximate range for metric units that is followed by the metric conversion to English units. The exact range of the parameter in metric units depends on the service tool that is being used. Each tool may use slightly different conversion factors.

Customer Parameter Lockout

The Customer Parameter Lockout is available in order to restrict access to changing some of the available parameters. Locking out a parameter requires customer passwords (if used). Once a parameter is locked out, factory passwords are required to change the parameter. Also, once a parameter is locked out, factory passwords are required to unlock the parameter.

If a lockable parameter is not locked out, factory passwords are not required. A locked out parameter restricts the parameter from being changed directly by the customer. This helps vehicle owners that are encountering problems with operators that are obtaining customer passwords and altering some of these parameters.

A locked out parameter also provides an audit trail. The audit trail can be used to determine the following information:

- Time of change
- Operator during change

The following customer parameters are available for lockout:

- "A/C Pressure Switch Fan-On Time" (Full feature)
- "Battery Monitor and Engine Control Voltage " (OCT01 and newer Personality Modules)
- "Battery Monitor and Low Idle Engine Control" (OCT01 and newer Personality Modules)
- "High Cruise Control Speed Set Limit"
- "High Speed Range Axle Ratio"
- "Input #6" (MAR99 Personality Modules through JUL01 Personality Modules)
- "Low Speed Range Axle Ratio"(MAR98 and newer Personality Modules)
- "Max PTO Vehicle Speed" (OCT01 and newer Personality Modules)
- "Soft Vehicle Speed Limit"
- "Top Engine Limit"
- "Transmission Style"
- "Two Speed Axle Switch" (OCT01 and newer Personality Modules)
- "Vehicle ID"
- "Vehicle Speed Cal J1939-ABS)" (OCT01 and newer Personality Modules)
- "Vehicle Speed Cal (J1939-Trans)"
- "Vehicle Speed Calibration"
- "Vehicle Speed Limit"
- "VSL Protection"

When an attempt to change a locked out parameter occurs, the “Factory Password” screen will come up. If changing the parameter is required, follow the instructions on the service tool display.

Factory passwords are also required to change a parameter from a locked parameter to an unlocked parameter. If more than one parameter is locked out, and each one needs to be unlocked, one factory password is required.

i01592289

Customer Specified Parameters Table

SMCS Code: 1901

Table 6

Customer Specified Parameter Table		
Parameter	Available Range or Options	Default
Selected Engine Rating	Dependent on engine power	
Vehicle ID Vehicle ID	17 Digits Available characters are dependent on the service tools.	all zeroes
Truck Manufacturer Parameters Truck Manufacturer Truck Model Type	GM, Other GMT-560	Not Programmed GM 530/540
Vehicle Speed Parameters Vehicle Speed Calibration Vehicle Speed CAL (J1939-Trans) Vehicle Speed CAL (J1939-ABS) Vehicle Speed Limit (VSL) VSL Protection Tachometer Calibration Soft Vehicle Speed Limit Low Speed Range Axle Ratio High Speed Range Axle Ratio	GM: 2485 to 238080 PPKM (4000 to 384000 PPM) Other: 2485 to 93226 PPKM (4000 to 15000 PPM) 0 rev per km (0 rev per mile) to 43000 rev per km (65000 rev per mile) 0 to 6.550 GM: 48 to 121 km/h (30 to 75 mph) Other: 48 to 204 km/h (30 to 127 mph) GM: 1700 rpm Other: 1700 to TEL rpm 2.0 to 500.0 ppr NO 0.00 to 19.99 0.0 to 9.99	GM: 19884 PPKM (32000 PPM) Other (Not Programmed) (Not Programmed) (Not Programmed) GM: 121 km/h (75 mph) Other: 204 km/h (127 mph) GM: 1700 rpm Other: TEL rpm GM: 17.5 ppr Other: 134.0 ppr YES 0.00 0.00
Cruise Control Parameters Low Cruise Control Speed Set Limit	GM: 48 to 121 km/h (30 to 75 mph) Other: 24 to 204 km/h (15 to 127 mph)	GM: 48 km/h (30 mph) Other: 204 km/h (127 mph)

(continued)

(Table 6, contd)

Customer Specified Parameter Table		
Parameter	Available Range or Options	Default
High Cruise Control Speed Set Limit	GM: 48 to 121 km/h (30 to 75 mph) Other: 32 to 204 km/h (20 to 127 mph)	GM: 121 km/h (75 mph) Other: 204 km/h (127 mph)
Engine Brake Mode	Coast, Latch or Manual	Manual
Cruise/Idle/PTO Switch Configuration	Set/Decel-Set/Accel	GM: Set/Decel Other: Set/Accel
Soft Cruise Control	YES or NO	GM: NO Other: YES
Idle Parameters		
Idle Vehicle Speed Limit	2 to 24 km/h (1 to 15 mph)	2 km/h (1 mph)
Idle RPM Limit	700 rpm to TEL rpm	TEL rpm
Idle/PTO RPM Ramp Rate	5 to 1000 rpm/sec	50 rpm/sec
Idle/PTO Bump RPM	5 to 500 rpm	20 rpm
Fast Idle RPM 1	700 rpm to TEL	1000 rpm
Fast Idle RPM 2	700 rpm to TEL	0 rpm
Dedicated PTO Parameters		
PTO Configuration	OFF Cab Switches Remote Switches Remote Throttle	OFF
PTO Top Engine Limit	700 to TEL rpm	TEL rpm
PTO Engine RPM Set Speed	Low idle rpm to PTO TEL rpm	0
PTO Engine RPM Set Speed A PTO Engine RPM Set Speed B	Low Idle rpm, PTO TEL rpm	0
PTO to Set Speed	YES or NO	NO
PTO Cab Controls RPM Limit	Low idle rpm, TEL rpm, or PTO TEL rpm	TEL rpm
PTO Vehicle Speed Limit	2 to 204 km/h (1 to 127 mph)	2 km/h (1 mph)
Torque Limit	135 N·m (100 lb ft) to Rated Torque	2712 N·m (2000 lb ft)
PTO Shutdown Time	3 to 1440 minutes	0
PTO Activates Cooling Fan	Normal, Continuous	Normal
Maximum PTO Enable Speed	700 rpm to TEL rpm	TEL rpm
Maximum PTO Vehicle Speed	24 to 204 km/h (15 to 127 mph)	204 km/h (127 mph)
PTO Active Output	J1/P1:19	None
Engine/Gear Parameters		
Lower Gears Engine RPM Limit	1500 to TEL rpm	TEL rpm
Lower Gears Turn Off Speed	2 to 24 km/h (1 to 15 mph)	2 km/h (1 mph)
Intermediate Gears Engine RPM Limit	1500 to TEL rpm	TEL rpm
Intermediate Gears Turn Off Speed	16 to 80 km/h (10 to 50 mph)	16 km/h (10 mph)
Gear Down Protection RPM Limit	1700 to TEL rpm	TEL rpm
Gear Down Protection Turn On Speed	GM: 48 to 121 km/h (30 to 75 mph) Other: 48 to 204 km/h (30 to 127 mph)	GM: 121 km/h (75 mph) Other: 204 km/h (127 mph)
Top Engine Limit (TEL)	Dependent on the engine and the rating	Dependent on the engine rating

(continued)

(Table 6, contd)

Customer Specified Parameter Table		
Parameter	Available Range or Options	Default
Low Idle Engine RPM	700 to 800 rpm	700 rpm
Idle Quality Calibration	Decrease 1, 2, 3, or 4 Increase 1, 2, 3, or 4, Nominal	Nominal
Transmission Style	GM: Universal Manual Option 1 Manual Option 2 Automatic Option 1 Automatic Option 2 Automatic Option 3 Automatic Option 4 AT/MT/HT Option 1 AT/MT/HT Option 2 AT/MT/HT Option 3 AT/MT/HT Option 4	GM 30/540: Universal GMT-560: Manual Option 2 Other: ManualOption 1
AT/MT/HT Part Throttle Shift Speed	Low and Medium	High
Fan Pulley Ratio	7.375	1.25
Governor Type	Min/Max	Full Range
Timer Parameters		
Idle Shutdown Time	3 to 1440 minutes	0 minutes
Allow Idle Shutdown Override	YES NO	YES
A/C Switch Fan-On Time Full Feature Only	0 to 600 seconds	0 seconds
Fan with Engine Brake On Full Feature Only	YES or NO	NO
Exhaust Brake Configuration	None, Warm Up Only, Exhaust Brake & Warm Up	GM 530/540: Exhaust Brake Only GMT-560: None Other: Exhaust Brake Only
Warm Up Mode Idle Speed	700 rpm to 1400 rpm	1000 rpm
Smart Idle Parameters		
Battery Monitor & Engine Control Voltage	0 Volts to 25.5 Volts	GM 530/540: 0 Volts GMT-560: 11.5 Volts Other: 0 Volts
Battery Monitor Low Idle Speed Monitor	700 rpm to TEL	1000 rpm
Engine Monitoring Parameters		
Engine Monitoring Mode	GM: OFF,DERATE Other: OFF,DERATE, SHUTDOWN	WARNING
Engine Monitoring Mode OCT01 and newer Personality Modules	GM 530/540: WARNING,DERATE GMT- 560 & Other: WARNING,DERATE SHUTDOWN	GM: WARNING Other: DERATE
Engine Monitoring Lamps (GM only)	High Coolant Temp Warning Lamp or Warning Lamp	Warning Lamp
Coolant Level Sensor	4-pin	GM: NA Other: NO

(continued)

(Table 6, contd)

Customer Specified Parameter Table		
Parameter	Available Range or Options	Default
Coolant Level Sensor OCT01 and newer Personality Modules	GM 530/540: 4-pin GMT- 560: NO Other: 2-wire Float Sensor	GM 530/540 & Other: NO GMT- 560: 2-pin
Oil Pressure Sensor	Installed or Not Installed	Not Installed
Oil Pressure Sensor OCT01 and newer Personality Modules	GM 530/540 & Other: Installed GMT- 560: Not Installed	GM 530/540 & Other: Not Installed GMT- 560: Installed
Oil Level Switch Installation Status GMT-560 Only	Not Installed	Installed
Primary Fuel Tank Size GMT-560 Only	None 25 gallons 35 gallons	50 gallons
Secondary Fuel Tank Size GMT-560 Only	25 gallons 35 gallons 50 gallons	None
Maintenance Parameters		
Maintenance Indicator Mode	OFF Manual Distance Manual Hours Automatic Distance Automatic Hours	OFF
PM 1 Interval (Manual Maintenance Indicator Mode)	8050 to 56325 km (5000 to 35000 miles) 100 to 750 hours	24140 km (15000 miles) 250 hours
Engine Oil Capacity (Automatic Maintenance Indicator Mode)	19 to 57 L (20 to 60 qt)	GM: 21 L (22 qt) Other: 31 L (33 qt)
Trip Parameters		
Dash - PM 1 Reset	YES or NO	NO
Dash - Customer Parameters	YES or NO	NO
Theft Deterrent System Control	YES, NO or AUTO-Enable	NO
Theft Deterrent Password	Four Characters A thru Z 0 thru 9	0000
Quick Stop Rate	0 km/h per second (0 mph per second) to 205 km/h per second (128 mph per second)	0 km/h per second (0 mph per second)
Input Selections		
Transmission Neutral Switch	None, J1939	J1/P1:62
Exhaust Brake Switch	Installed or Not Installed	Installed
Exhaust Brake Switch OCT01 and newer Personality Modules	J1/P1:16 J1939 Body Controller J1939 Cab Controller J1939 Instrument Cluster	None
Input #4 MAR98 through JUN01 Personality Modules	Torque Limit Switch	None
Torque Limit Switch OCT01 and newer Personality Modules	J1/P1:17 J1/P1:23	None

(continued)

(Table 6, contd)

Customer Specified Parameter Table		
Parameter	Available Range or Options	Default
Input #5 MAR99 through JUN01 Personality Modules	None, Ignore Brake/Clutch Switch	None
Ignore Brake/Clutch Switch OCT01 and newer Personality Modules	J1/P1:47	None
Input #6 MAR99 through JUN01 Personality Modules	None, 2-Speed Axle On/Off Switch	None
2-Speed Axle Switch OCT01 and newer Personality Modules	J1/P1:6	None
Input #7 JUL99 through JUN01 Personality Modules	None, Diagnostic Enable PTO Engine RPM Set Speed Input A	None
Diagnostic Enable OCT01 and newer Personality Modules	J1/P1:46 J1939 Body Controller J1939 Cab Controller J1939 Instrument Cluster	None
PTO Engine RPM Set Speed Input A OCT01 and newer Personality Modules	J1/P1:46	None
Input #19 JUL99 through JUN01 Personality Modules	None, PTO Engine RPM Set Speed Input B	None
PTO Engine RPM Set Speed Input B OCT01 and newer Personality Modules	J1/P1:7 J1/P1:23	None
PTO Engine Shutdown Switch OCT01 and newer Personality Modules	J1/P1:7 J1/P1:23	None
Cruise Control On/Off Switch OCT01 and newer Personality Modules	J1939 Body Controller J1939 Cab Controller J1939 Instrument Cluster	J1/P1:59
Cruise Control Set/Resume Switch OCT01 and newer Personality Modules	J1939 Body Controller J1939 Cab Controller J1939 Instrument Cluster	J1/P1:35 & 44
Cruise Pause Switch OCT01 and newer Personality Modules	J1939 Body Controller J1939 Cab Controller J1939 Instrument Cluster	None
A/C High Pressure Switch OCT01 and newer Personality Modules	None	J1/P1:41
A/C Fan Request Switch OCT01 and newer Personality Modules	J1/P1:41	J1/P1:2
Vehicle Speed Input	J1939-ABS J1939-Trans	J1/P1:32 & 33
Fan Override Switch OCT01 and newer Personality Modules	J1939 Body Controller J1939 Cab Controller J1939 Instrument Cluster	None
Service Brake Pedal Position Switch #1 OCT01 and newer Personality Modules	J1939 Body Controller J1939 Cab Controller J1939 Instrument Cluster	J1/P1:45

(continued)

(Table 6, contd)

Customer Specified Parameter Table		
Parameter	Available Range or Options	Default
Clutch Pedal Position Switch OCT01 and newer Personality Modules	J1939 Body Controller J1939 Cab Controller J1939 Instrument Cluster	J1/P1:22
Output Selections		
Output #9 OCT98 through JUN01 Personality Modules	Wait to Start Lamp Fast Idle Lamp	GM: Unavailable Other: Fast Idle Lamp
Fast Idle Enable Lamp OCT01 and newer Personality Modules	None	Other: J1/P1:31 GMT-560: J1/P1:21
Wait To Start Lamp This feature is only available when "Truck Manufacturer" is programmed to "Other".	J1/P1:31	None
Change Oil Lamp OCT01 and newer Personality Modules	None	J1/P1:30
Fan Control Type (Full Feature Only) Personality Modules prior to JUN01	On/Off	None
Fan Control Type OCT01 and newer Personality Modules	GM: On/Off, Variable Speed Option S GMT-560: On/Off, Variable Speed Option B, Variable Speed Option B25, Variable Speed Option B27 Other: On/Off, Variable Speed Option S	None
Engine Running Output OCT01 and newer Personality Modules	J1/P1:31	None
Starting Aid Output OCT01 and newer Personality Modules	Automatic	OFF
Customer Passwords		
Customer Password (1)	8 Digits	
Customer Password (2)	Available characters are dependent on the service tools.	
Data Link Parameters		
Power train Data Link	None, J1939	GM: J1939 Other: None

i01596107

Table 9

Customer Specified Parameters Worksheet

SMCS Code: 1901

Truck Manufacturer Parameters	
Truck Manufacturer	
Truck Model Type	

Table 7

Selected Engine Rating	
Rating Number	

Table 8

ECM Identification Parameters	
Vehicle ID	

Table 10

Vehicle Speed Parameters	
Vehicle Speed Calibration (PPM)	
Vehicle Speed CAL (J1939-Trans)	
Vehicle Speed CAL (J1939-ABS)	
Vehicle Speed Limit (VSL)	
VSL Protection (rpm)	
Tachometer Calibration (PPR)	
Soft Vehicle Speed Limit	
Low Speed Range Axle Ratio	
High Speed Range Axle Ratio	

Table 11

Cruise Control Parameters	
Low Cruise Control Speed Set Limit	
High Cruise Control Speed Set Limit	
Engine Brake Mode	
Cruise/Idle/PTO Switch Configuration	
Soft Cruise Control	

Table 12

Idle Parameters	
Idle Vehicle Speed Limit	
Idle RPM Limit	
Idle/PTO RPM Ramp Rate (rpm/sec)	
Idle/PTO Bump RPM	
Fast Idle RPM (1)	
Fast Idle RPM (2)	

Table 13

Dedicated PTO Parameters	
PTO Configuration	
PTO Top Engine Limit	
PTO Engine RPM Set Speed	
PTO Engine RPM Set Speed Input A	
PTO Engine RPM Set Speed Input B	
PTO to Set Speed	
PTO Cab Throttle RPM Limit	
PTO Vehicle Speed Limit	
Torque Limit	
PTO Shutdown Time	
PTO Activates Cooling Fan	
Maximum PTO Enable Speed	
Maximum PTO Vehicle Speed	
PTO Active Output	

Table 14

Engine/Gear Parameters	
Lower Gears Engine RPM Limit	
Lower Gears Turn Off Speed	
Intermediate Gears Engine RPM Limit	
Intermediate Gears Turn Off Speed	
Gear Down Protection RPM Limit	
Gear Down Protection Turn On Speed	
Top Engine Limit (TEL)	
Low Idle Engine rpm	
Idle Quality Calibration	
Transmission Style	
AT/MT/HT Part Throttle Shift Speed	
Fan Pulley Ratio	
Governor Type	

Table 15

Timer Parameters	
Idle Shutdown Time (minutes)	
Allow Idle Shutdown Override	
A/C Switch Fan-On Time	
Fan with Engine Brake On	
Exhaust Brake Configuration	
Warm Up Mode Idle Speed	

Table 16

Engine Monitoring Parameters	
Engine Monitoring Mode	
Engine Monitoring Lamps (GM only)	
Coolant Level Sensor	
Oil Pressure Sensor	
Oil Level Switch Installation Status GMT-560 Only	
Primary Fuel Tank Size GMT-560 Only	
Secondary Fuel Tank Size GMT-560 Only	

Table 17

Maintenance Parameters	
Maintenance Indicator Mode	
PM 1 Interval (Distance/Hrs.)	
Engine Oil Capacity (Quarts/Liters)	

Table 18

Trip Parameters	
Dash - PM 1 Reset	
Dash - Customer Parameters	
Theft Deterrent Control System	
Theft Deterrent Password	
Quick Stop Rate	

Table 19

Input Selections	
Transmission Neutral Switch	
Exhaust Brake Switch	
Input No. 4	
Torque Limit Switch OCT01 and newer Personality Modules	
Input No. 5	
Ignore Brake/Clutch Switch OCT01 and newer Personality Modules	
Input No. 6	
2-Speed Axle Switch OCT01 and newer Personality Modules	
Input No. 7	
Diagnostic Enable OCT01 and newer Personality Modules	
Input No. 19	
PTO Engine RPM Set Speed Input B OCT01 and newer Personality Modules	
PTO Engine Shutdown Switch OCT01 and newer Personality Modules	
Cruise Control On/Off Switch OCT01 and newer Personality Modules	
Cruise Control Set/Resume Switch OCT01 and newer Personality Modules	
Cruise Pause Switch OCT01 and newer Personality Modules	
A/C High Pressure Switch OCT01 and newer Personality Modules	
A/C Fan Request Switch OCT01 and newer Personality Modules	
Vehicle Speed Input	
Fan Override Switch OCT01 and newer Personality Modules	

(continued)

(Table 19, contd)

Input Selections	
Service Brake Pedal Position Switch #1 OCT01 and newer Personality Modules	
Clutch Pedal Position Switch OCT01 and newer Personality Modules	

Table 20

Output Selections	
Output No. 9	
Fast Idle Enable Lamp OCT01 and newer Personality Modules	
Wait To Start Lamp This feature is only available when "Truck Manufacturer" is programmed to "Other".	
Change Oil Lamp OCT01 and newer Personality Modules	
Fan Control Type	
Engine Running Output OCT01 and newer Personality Modules	
Starting Aid Output OCT01 and newer Personality Modules	

Table 21

Customer Passwords	
Customer Password (1)	
Customer Password (2)	

Table 22

Data Link Parameters	
Power train Data Link	

Current Totals Worksheet

Table 23

Lifetime Totals	
Total Time	
Total PTO Time	
Total Idle Time	
Total Distance	
Total Fuel	
Total PTO Fuel	
Total Idle Fuel	

i01727005

Cruise Control Parameters

SMCS Code: 1901

“Low Cruise Control Speed Set Limit”

The “Low Cruise Control Speed Set Limit” sets the lowest vehicle speed that will allow the cruise control to be set. Programming this parameter to the maximum value disables cruise control.

Table 24

Manufacturer	Minimum	Maximum	Default
GM	48 km/h (30 mph)	121 km/h (75 mph)	48 km/h (30 mph)
Other	24 km/h (15 mph)	204 km/h (127 mph)	204 km/h (127 mph)

“High Cruise Control Speed Set Limit”

The “High Cruise Control Speed Set Limit” sets the highest vehicle speed that will allow the cruise control to be set. If a driver attempts to set a vehicle speed higher than this limit, the “High Cruise Control Speed Set Limit” will be the cruise set speed. If the “High Cruise Control Speed Set Limit” is programmed to a value that is greater than the “Vehicle Speed Limit”, the cruise control switches can be used to exceed the programmed “Vehicle Speed Limit”.

Table 25

Manufacturer	Minimum	Maximum	Default
GM	48 km/h (30 mph)	121 km/h (75 mph)	121 km/h (75 mph)
Other	32 km/h (20 mph)	204 km/h (127 mph)	204 km/h (127 mph)

“Engine Brake Mode”

“Engine Brake Mode” determines the operation of the engine brake while the cruise control on/off switch is in the ON position but the engine is not in cruise control. This does not determine the operation of the engine brake while the engine is in cruise control. Also, this does not allow operation of the engine brake while the engine is in cruise control.

The following modes are allowable options:

- Coast
- Latch
- Manual

When the “Engine Brake Mode” is programmed to the Coast Mode, the engine brake is enabled only while the service brakes are being applied. When the ECM is programmed to the Latch Mode, the engine brake stays enabled after the service brakes are released. A direct, immediate pressure on the brake pedal latches the engine brake in the ON position and the engine brake will remain in the ON position until the accelerator pedal is depressed.

When the “Engine Brake Mode” is programmed to the Manual Mode, the engine brake operates independently of the cruise control status.

The engine brake operates with the application and the release of the service brake in the Coast Mode.

The engine brake turns on with the application of the service brakes in the Latch Mode. The engine brake stays on even when the service brakes are released.

Table 26

Alternative	Default
“Coast” “Latch”	“Manual”

“Cruise/Idle/PTO Switch Configuration”

“Cruise/Idle/PTO Switch Configuration” defines the function of the set/resume switch for “ACCEL” mode and “DECEL” mode. This parameter affects cruise control mode, idle mode and PTO mode.

Table 27

Manufacturer	Alternative	Default
GM	“Set/Accel-Res/Decel”	“Set/Decel-Res/Accel”
Other	“Set/Decel-Res/Accel”	“Set/Accel-Res/Decel”

“Soft Cruise Control”

“Soft Cruise Control” provides a 8 km/h (5 mph) operating range around the cruise control set speed in order to provide a smoother cruise control. “Soft Cruise Control” controls the cruise speed within the following range:

- 4 km/h (2.5 mph) below the set vehicle speed at full load
- 4 km/h (2.5 mph) above the set vehicle speed at no load

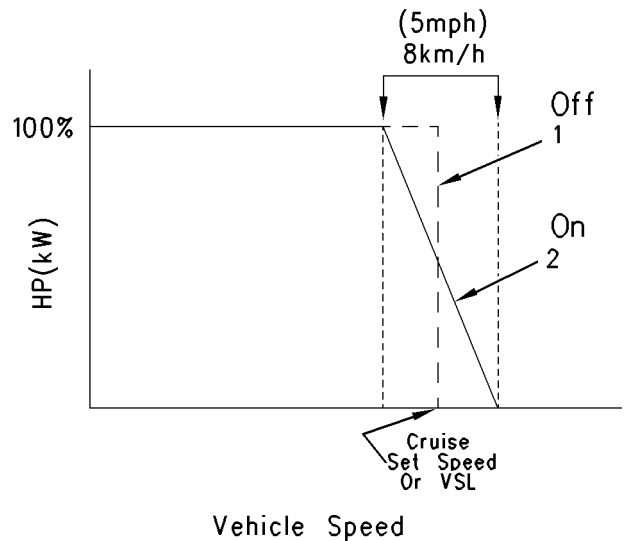

Illustration 14

g00670797

Soft Cruise control and soft vehicle speed limit

Table 28

Manufacturer	Alternative	Default
GM	“YES”	“NO”
Other	“NO”	“YES”

i01728860

Data Link Parameters

SMCS Code: 1901

“Powertrain Data Link”

This parameter must be programmed to “J1939” in order to receive any switch inputs from the “J1939” data link. This parameter determines if the ECM will communicate to a power train component by using the J1939 data link. If the vehicle is not using the data link for communication to the power train systems, this parameter should be programmed to “NONE”. The following systems are examples of power train systems:

- Traction control systems
- Anti-lock brake systems
- Electronically controlled transmissions

Note: A 231-11 J1939 Data Link Fault(58) will occur if the parameter for the power train data link is set to J1939 without a J1939 power train ECM on the vehicle. The J1939 power train ECM is used to communicate with the engine ECM.

Table 29

Manufacturer	Alternative	Default
GM	“NONE”	“J1939”
Other	“J1939”	“NONE”

i01727043

Dedicated PTO Parameters

SMCS Code: 1901

“PTO Configuration”

The “PTO Configuration” determines the features that are available for dedicated PTO applications and the input signals that are used for dedicated PTO applications. When the “PTO Configuration” is programmed to “OFF”, the application does not use the settings for the PTO. The remaining programmable options for the PTO require a PTO on/off circuit that is connected to ECM input 1 (ECM connector J1/P1:56). A PTO switch on lamp can also be connected to output 1 (ECM J1/P1 terminal 30).

If the parameter “PTO Configuration” is programmed to the “Cab Switches”, the ECM will use the signals from the following two switches for PTO control and cruise control:

- Cab set switch (J1/P1:35)
- Resume switch (J1/P1:44)

Note: When an exhaust particulate filter is installed, the parameter “PTO Configuration” is automatically programmed to “Cab Switches”. This parameter cannot be reprogrammed.

If the parameter “PTO Configuration” is programmed to “Remote Switches”, the ECM will monitor programmed signals such as the remote set switch and remote resume switch. Signals from the cab controls will be ignored when the PTO on/off circuit is on. The following components are cab controls:

- Brake switch
- Clutch switch
- Accelerator
- Cruise control switches

If the parameter “PTO Configuration” is programmed to “Remote Throttle”, the ECM will monitor input 8 (J1/P1:68) for the remote accelerator pedal. The ECM will monitor programmed signals and the ECM will ignore all cab controls when the PTO on/off circuit is on.

Table 30

Alternative	Default
“Cab Switches”, “Remote Switches”, and “Remote Throttle”	“OFF”

“PTO Top Engine Limit”

The “PTO Top Engine Limit” is the top engine limit that is available by using a PTO on/off circuit that is connected to input 1 of ECM connector (J1/P1:56).

Note: The “PTO Configuration” must be programmed to “Cab Switches”, “Remote Switches”, or “Remote Throttle” before this parameter can be programmed.

Table 31

Minimum	Maximum	Default
700	TEL rpm	TEL rpm

“PTO Engine RPM Set Speed”

The “PTO Engine RPM Set Speed” is the engine rpm that is allowed by the ECM when the PTO on/off circuit is on and the set switch is actuated.

If the “PTO to Set Speed” parameter is programmed to “YES”, the engine will proceed to this speed whenever the PTO on/off circuit is turned on.

Note: “PTO Configuration” must be programmed to “Cab Switches” or “Remote Switches” for this parameter to function.

This parameter must be programmed higher than the programmed low idle. If the “PTO to Set Speed” is programmed to a higher value than the “PTO Top Engine Limit”, the set speed will be limited by the lower “PTO Top Engine Limit”.

For one rpm set speed above low idle, program the “PTO Top Engine Limit” to the same rpm as the “PTO Engine RPM Set Speed”.

For two rpm set speeds above low idle, program this parameter to some intermediate value between the low idle and the “PTO Top Engine Limit”.

Move the PTO on/off switch to the ON position. Toggle the set switch once in order to cause the rpm to advance to the “PTO Engine RPM Set Speed”. Toggle the set switch again in order to increase the engine rpm to the “PTO Top Engine Limit”. Toggling the resume switch decreases the engine rpm to the previous set speed.

Table 32

Minimum	Maximum	Default
Low Idle rpm	PTO TEL rpm	0 rpm

“PTO Engine RPM Set Speed Input A”

JUL99 and newer Personality Modules.

If the “PTO Engine RPM Set Speed A” parameter is programmed to the corresponding switch input option, the switch is used in order to control engine speed during PTO operation. The “PTO Configuration” parameter must be programmed to “Cab Switches”, “Remote Switches”, or “Remote Throttle” and the “PTO Engine RPM Set Speed A” parameter must be programmed to a valid speed.

Table 33

Minimum	Maximum	Default
Low Idle rpm	PTO TEL rpm	0 rpm

Table 34

Minimum	Maximum	Default
Low Idle rpm	PTO TEL rpm	0 rpm

“PTO Engine RPM Set Speed Input B”

JUL99 and newer Personality Modules.

If the “PTO Engine RPM Set Speed B” parameter is programmed to the corresponding switch input option, the switch is used in order to control engine speed during PTO operation. The “PTO Configuration” parameter must be programmed to “Cab Switches”, “Remote Switches”, or “Remote Throttle” and the “PTO Engine RPM Set Speed B” parameter must be programmed to a valid speed.

“PTO to Set Speed”

This parameter causes the ECM to proceed to the programmed “PTO Engine RPM Set Speed” when the PTO on/off switch is on. “PTO Configuration” must be programmed to “Cab Switches” or “Remote Switches” before this parameter can be programmed.

Note: This parameter is not available when “PTO Configuration” is programmed to “Remote Throttle”.

Table 35

Alternative	Default
“YES”	“NO”

“PTO Cab Throttle RPM Limit”

This determines the engine rpm limit of the pedal position sensor for the cab accelerator and the cab set/resume switch when “PTO Configuration” is programmed to “Cab Switches” and the PTO on/off circuit is on. This parameter is intended to prevent engine overspeed when the dedicated PTO is used.

- If the parameter is programmed to “Low Idle”, the cab controls are ignored.
- If the parameter is programmed to “Top Engine Limit” (TEL), the engine will operate to the programmed “Top Engine Limit”.
- If the parameter is programmed to “PTO Top Engine Limit”, the engine will operate to the programmed “PTO Top Engine Limit”.

Note: “PTO Configuration” must be programmed to “Cab Switches” for this parameter to take effect. If “PTO Configuration” is programmed to “Remote Switches” or “Remote Throttle”, the ECM will always ignore the cab controls when the PTO on/off circuit is on.

Table 36

Alternative	Default
“Low Idle”, “TEL” and “PTO TEL”	“TEL”

“PTO Kickout Vehicle Speed Limit ”

This is the maximum vehicle speed for setting or maintaining a set engine rpm in PTO mode. PTO Mode is entered if the PTO on/off switch is on. (This uses input 1.) If the vehicle speed signal exceeds this value, the engine will not maintain the set engine rpm.

Table 37

Minimum	Maximum	Default
2 km/h (1 mph)	204 km/h (127 mph)	2 km/h (1 mph)

“Torque Limit”

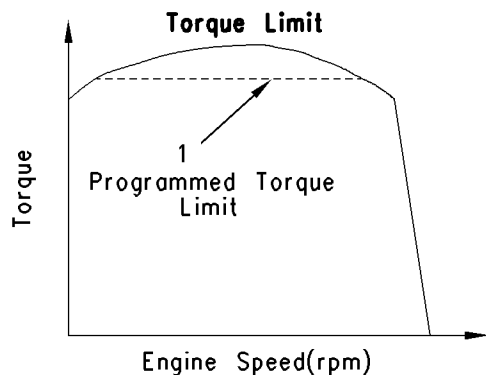

Illustration 15

g00628600

Operation of torque limit
(1) Programmed torque limit

The parameter for the “Torque Limit” defines the maximum torque output of the engine during dedicated PTO operation. This parameter provides temporary protection of equipment. The “Torque Limit” of the engine is active when the circuit for the torque limit switch is on. The maximum value is the rated torque of the engine. The “Torque Limit” is programmable to N·m (lb ft) of torque. Programming a value higher than the rated torque is limited by the ECM to rated torque. The torque limit is indicated by the dashed line in Illustration 15.

Table 38

Minimum	Maximum	Default
135 N·m (100 lb ft)	2712 N·m (2000 lb ft)	2712 N·m (2000 lb ft)

“PTO Shutdown Time”

The “PTO Shutdown Time” is the time (minutes) of engine operation with the PTO on/off circuit ON and no vehicle speed before shutting down. The timer will only count with no vehicle speed and the PTO on/off circuit turned on. The PTO shutdown timer will not begin counting if the engine is in Cold Mode. This parameter requires the “PTO Configuration” to be programmed to “Cab Switches”, “Remote Switches”, or “Remote Throttle” for the timer to function.

Note: This feature does not shut down the vehicle’s power. The ECM and the vehicle remain powered.

Table 39

Manufacturer / Model	Range	Default
GM 530/540	3 minutes to 1440 minutes	1440 minutes
GMT-560		0 minutes
Other		

“PTO Activates Cooling Fan”

This parameter requires the use of the ECM cooling fan circuit. When this parameter is programmed to “Continuous”, the ECM will signal the cooling fan to run continuously when the PTO on/off circuit is on. The cooling fan runs continuously in order to reduce changes in the load while the engine is being used for dedicated PTO applications. When this parameter is programmed to “Normal”, the PTO on/off circuit does not affect the cooling fan. In this mode, the operation of the fan is based on coolant temperature, inlet air temperature or air conditioning high head pressure. The “PTO Configuration” must be programmed to “Cab Switches”, “Remote Switches”, or “Remote Throttle” before this parameter can be programmed. The “Fan Control Type” must be programmed to “On/Off”.

Table 40

Alternate	Default
“Continuous”	“Normal”

“Maximum PTO Enable Speed”

This parameter specifies the maximum engine speed for the engagement of the PTO mode. The PTO mode will engage when the engine rpm is equal to the programmed limit or less than the programmed limit.

Table 41

Minimum	Maximum	Default
700 rpm	TEL rpm	TEL rpm

“PTO Active Output ”

OCT01 and newer Personality Modules.

The output driver is capable of providing 1.0 Amp when the PTO mode is active. The output is on if the following conditions are met:

- The PTO switch is on.
- PTO Mode is active.
- The engine speed is within the programmed limits.
- The vehicle speed is within the programmed limits.

Table 42

Alternate	Default
“J1/P1:19”	“None”

i01727137

Engine/Gear Parameters

SMCS Code: 1901

“Lower Gears Engine RPM Limit”

The engine will accelerate at a slower rate when this limit is exceeded under normal driving conditions. This parameter is used to encourage the driver to shift to the next highest gear.

Table 43

Minimum	Maximum	Default
1500 rpm	TEL rpm	TEL rpm

“Lower Gears Turn Off Speed”

The “Lower Gears Turn Off Speed” parameter is the vehicle speed when the “Lower Gears Engine RPM Limit” is shut off. This must be matched with the “Lower Gears Engine RPM Limit” to the specific drive train for best performance.

Table 44

Minimum	Maximum	Default
2 km/h (1 mph)	24 km/h (15 mph)	2 km/h (1 mph)

“Intermediate Gears Engine RPM Limit”

This parameter is similar to the “Lower Gears Engine RPM Limit”. The engine will accelerate at a slower rate when this limit is exceeded under normal driving conditions. This parameter is typically programmed to a slightly higher rpm than the “Lower Gears Engine RPM Limit”.

Table 45

Minimum	Maximum	Default
1500 rpm	TEL rpm	TEL rpm

“Intermediate Gears Turn Off Speed”

This parameter is similar to the “Lower Gears Turn Off Speed”. This parameter is typically programmed to a slightly higher vehicle speed than the “Lower Gears Turn Off Speed”.

Table 46

Minimum	Maximum	Default
16 km/h (10 mph)	80 km/h (50 mph)	16 km/h (10 mph)

“Gear Down Protection RPM Limit”

This parameter is the engine rpm limit when the vehicle speed is above the “Gear Down Protection Turn On Speed”. This is a hard limit. The ECM will not allow fuel to the engine above this limit. This parameter is used to encourage the driver to shift into overdrive or top gear.

Table 47

Minimum	Maximum	Default
1700 rpm	TEL rpm	TEL rpm

“Gear Down Protection Turn On Speed”

This parameter is the vehicle speed when the “Gear Down Protection RPM Limit” is turned on. This must be matched to the specific drive train for best performance. Above this “Vehicle Speed Limit”, the engine rpm will be limited by the “Gear Down Protection RPM Limit”.

Table 48

Manufacturer	Minimum	Maximum	Default
GM	48 km/h (30 mph)	121 km/h (75 mph)	121 km/h (75 mph)
Other	48 km/h (30 mph)	204 km/h (127 mph)	204 km/h (127 mph)

“Top Engine Limit (TEL)”

This parameter is the maximum engine rpm when the engine is under load. The engine will still achieve rated rpm under no load conditions.

Table 49

Minimum	Maximum	Default
2640 rpm	2640 rpm	2640 rpm

Note: Select ratings have a different “Top Engine Limit”.

“Low Idle Engine RPM”

The “Low Idle Engine RPM” is the minimum engine rpm.

Table 50

Minimum	Maximum	Default
700 rpm	800 rpm	700 rpm

“Idle Quality Calibration”

This parameter should not be adjusted without first consulting a Caterpillar representative.

Table 51

Alternative	Default
Decrease 1, 2, 3, or 4, Increase 1, 2, 3, or 4	Nominal

“Transmission Style”

(Full Feature Only)

This parameter is used to tell the ECM the type of transmission that is installed in the vehicle. This parameter is used by the ECM to read the signals from the following devices:

- Brake switch (No. 2)
- Clutch switch

- Neutral switch
- Output (No. 7)

The ECM must be programmed to one of the following options if an Allison Wt Automatic Transmission transmission is installed:

- AT/MT/HT option 1
- AT/MT/HT option 2
- AT/MT/HT option 3
- AT/MT/HT option 4

If any other automatic transmission is installed, this parameter should be programmed to one of the following options:

- Automatic Option 1
- Automatic Option 2
- Automatic Option 3
- Automatic Option 4

If one of the manual options is selected, terminal J1/P1:24 must receive a signal from a clutch pedal position switch or a message from a clutch switch from one of the supported J1939 sources. If one of the transmissions with a neutral switch is selected, terminal J1/P1:62 must receive a signal from a transmission neutral switch or a message from a neutral switch from one of the supported J1939 sources. If one of the transmissions with two brake switches is selected, the second brake switch must be connected to terminal J1/P1:64.

Table 52

Setting For Transmission Style Parameter	Switch Usage.			
	Service Brake Switch 1	Service Brake Switch 2	Clutch	Neutral
“Manual Option 1”	X		X	
“Manual Option 2”	X	X	X	
“Automatic Option 1”	X			
“Automatic Option 2”	X	X		
“Automatic Option 3”	X	X		X
“Automatic Option 4”	X			X
“AT/MT/HT Option 1”	X			
“AT/MT/HT Option 2”	X	X		
“AT/MT/HT Option 3”	X	X		X
“AT/MT/HT Option 4”	X			X
“Universal Option”	X	X	X	X

Table 53

Manufacturer / Model	Alternative	Default
GM	“Automatic Option 1”, “Automatic Option 2”, “Automatic Option 3”, “Automatic Option 4”, “AT/MT/HT Option 1”, “AT/MT/HT Option 2”, “AT/MT/HT Option 3”, “AT/MT/HT Option 4”	Universal
GMT-560	“Manual Option 1” “Manual Option 2”	“Manual Option 2”
Other	“Automatic Option 1”, “Automatic Option 2”, “Automatic Option 3”, “Automatic Option 4”, “AT/MT/HT Option 1”, “AT/MT/HT Option 2”, “AT/MT/HT Option 3”, “AT/MT/HT Option 4”	“Manual Option 1”

“AT/MT/HT Part Throttle Shift Speed”

JUL99 and newer Personality Modules.

Allison Wt Automatic Transmissions require an input from the ECM to regulate the transmission shifting. The ECM monitors the accelerator pedal position, engine speed, vehicle speed, load, cruise control status and neutral switch status in order to determine if the transmission should use closed throttle or full throttle shift modulation. The “AT/MT/HT Part Throttle Shift Speed” parameter provides three different settings for shift modulation.

Table 54

Alternative	Default
“Low” (80% Enable / 65% Disable) “Medium” (70% Enable / 55% Disable)	“High” (60% Enable / 45% Disable)

Programming the “Transmission Style” to “AT/MT/HT Option 1”, “AT/MT/HT Option 2”, “AT/MT/HT Option 3”, or “AT/MT/HT Option 4” activates ECM output 7. This output controls a shift relay that is connected to a modulator in the Allison transmission.

The high setting will cause the transmission to remain in a lower gear longer before upshifting to the next gear. The medium setting is a compromise between the default setting and the high setting.

“Fan Pulley Ratio”

Note: This feature is only available when “Truck Manufacturer” is programmed to “GMT-560”.

OCT01 and newer Personality Modules.

This variable is used to calculate the actual fan speed for control of the fan.

Table 55

Minimum	Maximum	Default
0	7.375	1.25

“Governor Type”

OCT01 and newer Personality Modules.

This parameter determines the type of governor that controls the engine. The Full Range governor tries to maintain a constant engine speed for a throttle position. The Min/Max Governor only governs engine speed when the engine speed is at the minimum allowable engine speed or at the maximum allowable engine speed. When the engine is operating between the engine speed limits, the Min/Max Governor tries to keep power constant across the engine speed range.

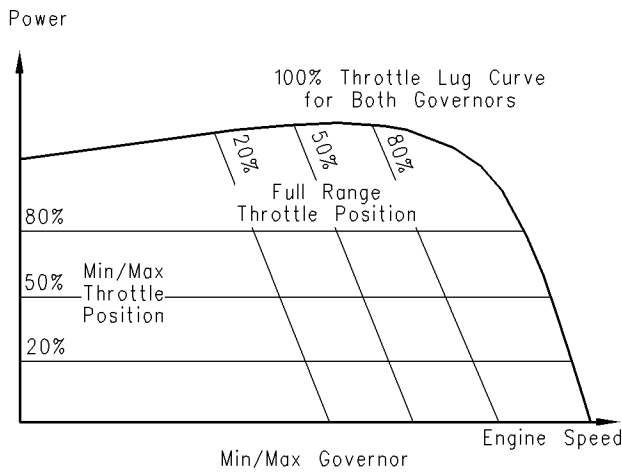

Illustration 16 g00837953
Graph for the Min/Max Governor

Select "Full Range" for manual transmissions and for electronically shifted manual transmissions. Select "Min/Max" for automatic transmissions.

Table 56

Alternative	Default
"Min/Max"	"Full Range"

i01858290

Engine Monitoring Parameters

SMCS Code: 1901

"Engine Monitoring Mode"

This parameter determines the level of action that will be taken by the ECM in response to a condition that has the capability to damage the engine. The ECM reads the Caterpillar coolant temperature sensor and the coolant level sensor, if equipped. If the ECM has been programmed to monitor the OEM installed coolant level sensor, the ECM will read that sensor.

Table 57

Manufacturer	Alternative	Default
GM	"OFF", "DERATE"	"WARNING"
Other	"OFF", "DERATE" and "SHUTDOWN"	"WARNING"

OCT01 and newer Personality Modules.

Table 58

Manufacturer or Model	Alternative	Default
GM 530/540	"WARNING", "DERATE"	"WARNING"
GMT-560	"WARNING", "DERATE", and "SHUTDOWN"	
Other		"DERATE"

"Engine Monitoring Lamps"

The "Engine Monitoring Lamps" parameter is only available for the GM Truck Manufacturer configuration. The "Warning Lamp" option configures "Output #9" to be used for the connection of a warning lamp for use with the Caterpillar Engine Monitoring System. The optional "High Coolant Temp Warning Lamp" setting configures the ECM to provide an indication when engine coolant temperature is abnormally high. This circuit is used to interface the GM Vehicle Shutdown System. When output 9 is programmed to "High Coolant Temp Warning Lamp", you can not use the output for a warning lamp for the Caterpillar Monitoring System.

Table 59

Manufacturer	Alternative	Default
GM	"High Coolant Temp Warning Lamp"	"Warning Lamp"
Other	N/A	N/A

OCT01 and newer Personality Modules.

Table 60

Manufacturer or Model	Alternative	Default
GM 530/540	"High Coolant Temp Warning Lamp"	"Warning Lamp"
GMT-560	"Warning Lamp"	"Warning Lamp"
Other		

"Coolant Level Sensor"

This parameter determines if the ECM monitors the input signal of the coolant level sensor. This feature requires the "Engine Monitoring Mode" to be programmed to "Warning", "Derate", or "Shutdown". An OEM installed coolant level sensor must be connected to the ECM in order to use this parameter.

Table 61

Manufacturer	Alternative	Default
GM	N/A	N/A
Other	“4-pin connector”	“NO”

OCT01 and newer Personality Modules.

Table 62

Manufacturer or Model	Alternative	Default
GM 530/540	“4-pin”	“NO”
GMT-560	“NO”	“2-pin switch”
Other	“2-wire float sensor”	“NO”

“Engine Oil Pressure Sensor”

JUN98 and newer Personality Module.

An optional engine oil pressure sensor is sometimes installed on applications with an instrument cluster that requires an engine oil pressure gauge. The 3126B engine and the 3126E engine does not require an engine oil pressure indicator for engine protection. The HEUI fuel system will not allow the engine to run if no engine oil pressure is present.

If the engine oil pressure sensor is installed in the engine, the “Engine Oil Pressure Sensor” parameter must be set to “Installed”. The engine oil pressure signal will be communicated over the ATA Data link.

Table 63

Alternatives	Default
“Installed”	“Not Installed”

OCT01 and newer Personality Modules.

Table 64

Manufacturer or Model	Alternatives	Default
GM 530/540	“Installed”	“Not Installed”
GMT-560	“Not Installed”	“Installed”
Other	“Installed”	“Not Installed”

“Oil Level Switch Installation Status”

Note: This feature is only available when “Truck Manufacturer” is programmed to “GMT-560”.

OCT01 and newer Personality Modules.

This parameter is used to tell the ECM that an oil level sensor is installed.

Table 65

Alternatives	Default
“Not Installed”	“Installed”

“Primary Fuel Tank Size”

Note: This feature is only available when “Truck Manufacturer” is programmed to “GMT-560”.

OCT01 and newer Personality Modules.

This parameter is used to identify the size of the primary fuel tank in gallons.

Table 66

Alternatives	Default
“None” “25 gallons” “35 gallons”	“50 gallons”

“Secondary Fuel Tank Size”

Note: This feature is only available when “Truck Manufacturer” is programmed to “GMT-560”.

OCT01 and newer Personality Modules.

This parameter is used to identify the size of the secondary fuel tank in gallons.

Table 67

Alternatives	Default
“25 gallons” “35 gallons” “50 gallons”	“None”

i01727019

Idle Parameters

SMCS Code: 1901

“Idle Vehicle Speed Limit”

The “Idle Vehicle Speed Limit” is the maximum vehicle speed for setting or maintaining a set engine rpm in the idle mode. In order to enter the idle mode, the engine rpm must be set by the set/resume switch while the cruise control on/off switch is in the ON position. If the vehicle speed signal exceeds this value, the engine will not maintain the set engine rpm.

Table 68

Minimum	Maximum	Default
2 km/h (1 mph)	24 km/h (15 mph)	2 km/h (1 mph)

“Idle RPM Limit”

The “Idle RPM Limit” is the maximum engine rpm in idle mode. The Idle Mode occurs if the engine rpm is set by using the cruise control on/off switch and the set/resume switch. Refer to “Idle Vehicle Speed Limit”. The actual high limit of this parameter is determined by the programmed “Top Engine Limit”. The lower limit is determined by the programmed “Low Idle Engine RPM”.

Programming this parameter to 600 rpm will prevent the engine from idling at a constant rpm above the programmed “Low Idle Engine RPM”.

Table 69

Minimum	Maximum	Default
700 rpm	TEL rpm	TEL rpm

“Idle/PTO RPM Ramp Rate”

The “Idle/PTO RPM Ramp Rate” determines the rate of increase or decrease of engine rpm. This parameter determines rates of increase or decrease in engine rpm for the following functions:

- Accel.
- Decel.
- Resume Idle
- PTO

The parameter can be set to a value between 5 rpm and 1000 rpm in one rpm increments.

Note: The parameter affects both idle control and PTO control. The idle mode occurs if the engine rpm is set by using the cruise control on/off switch and the set/resume switch. The PTO mode occurs if the engine rpm is set by using the PTO on/off switch and the set/resume switch.

Table 70

Minimum	Maximum	Default
5 rpm/sec	1000 rpm/sec	50 rpm/sec

“Idle/PTO Bump RPM”

The “Idle/PTO Bump RPM” determines the increment or the decrement in engine rpm when the Accel switch or the Decel switch is briefly toggled. The “Idle/PTO Bump RPM” also pertains to the dedicated PTO and idle. If a set speed has been programmed in parameter “PTO Engine RPM Set Speed”, the parameter “Idle/PTO Bump RPM” pertains only to the engine speed control that is initiated with the cruise control on/off switch. If a “PTO Engine RPM Set Speed” has been programmed, the “Idle/PTO Bump RPM” does not pertain to the control of the engine rpm that is initiated by utilizing the PTO on/off circuit.

Table 71

Minimum	Maximum	Default
5 rpm	500 rpm	20 rpm

“Fast Idle RPM 1”

“Fast Idle RPM 1” determines the fast idle engine rpm that is controlled by the fast idle enable switch. Actuating the fast idle switch will cause the engine speed to increase to the programmed value. This rpm can be overridden by the operator. To override the “Fast Idle RPM 1” setting, depress the accelerator pedal until the desired rpm is reached. Once the desired engine rpm is reached, depress the fast idle enable switch. This rpm setting will be the “Fast Idle RPM 1” until the ECM is shut down.

Table 72

Minimum	Maximum	Default
700 rpm	TEL rpm	1000 rpm

“Fast Idle RPM 2”

“Fast Idle RPM 2” determines the second fast idle engine rpm that is controlled by the fast idle enable switch. The “Fast Idle RPM 2” is disabled by changing the parameter to 0.

If the engine is operating at the “Fast Idle RPM 1” setting, actuating the fast idle enable switch will increase the engine idle speed to the engine speed that is programmed in the “Fast Idle RPM 2” parameter. The fast idle engine rpm will increase if the “Fast Idle RPM 2” parameter is set to a number higher than 0. Actuating the fast idle enable switch for a third time will cause the engine rpm to return to low idle. The engine rpm changes to “Fast Idle RPM 1”, “Fast Idle RPM 2”, and low idle rpm at a rate that is independent of the value that is programmed in the “Idle/PTO RPM Ramp Rate” parameter.

Table 73

Minimum	Maximum	Default
700 rpm	TEL rpm	0 rpm

i01728467

Input Selections

SMCS Code: 1901

“Transmission Neutral Switch”

This parameter is used to specify the input that will be used by the ECM to receive the status information from the Neutral Switch. The default J1/P1:62 configures the ECM to monitor pin 62 of the vehicle harness connector for a connection for the neutral switch circuit.

The ECM can also be configured to receive the status of the neutral switch via the J1939 data link. The transmission ECU must be capable of supporting the required protocol of the broadcast announcement message.

Table 74

Alternative	Default
“J1939”, “None”	“J1/P1:62”

OCT01 and newer Personality Modules.

Table 75

Manufacturer / Model	Alternatives	Default
GM 530/540	“J1939”, “None”	“J1/P1:62”
GMT-560	“J1/P1:62”, “None”	“J1939”
Other	“J1939”, “None”	“J1/P1:62”

“Exhaust Brake Switch”

The exhaust brake can be controlled by connecting an on/off switch into the ECM circuit for the output of the exhaust brake. The “Exhaust Brake Switch” parameter must be programmed to “Not Installed” if a switch is installed in the output circuit. A switch that is installed in the output circuit will disable the brake by opening the output circuit.

The exhaust brake can also be controlled by connecting a switch circuit to the ECM switch input. This parameter must be programmed to “Installed” if a switch is connected to the ECM at the dedicated input for the exhaust brake.

Table 76

Alternative	Default
“Installed”	“Not Installed”

OCT01 and newer Personality Modules.

The exhaust brake can be controlled by connecting an on/off switch into the ECM circuit for the output of the exhaust brake. The “Exhaust Brake Switch” parameter must be programmed to “NONE” if a switch is installed in the output circuit. A switch that is installed in the output circuit will disable the brake by opening the output circuit.

The exhaust brake can also be controlled by connecting a switch circuit to the ECM switch input. This parameter must be programmed to “J1/P1:16”, “J1939 Body Controller”, “J1939 Cab Controller”, or “J1939 Instrument Cluster” if a switch is connected to the ECM at the dedicated input for the exhaust brake.

Table 77

Alternative	Default
“J1/P1:16” “J1939 Body Controller” “J1939 Cab Controller” “J1939 Instrument Cluster”	“NONE”

“Input #4”

MAR98 through JUN01 Personality Modules.

The “Input #4” to the ECM can be used to connect a torque limit switch in order to limit the engine torque. This feature should only be used for temporary protection of equipment. This parameter must be programmed to “Torque Limit Switch” in order to enable this feature.

Table 78

Alternative	Default
“Torque Limit Switch”	“NONE”

“Torque Limit Switch”

OCT01 and newer Personality Modules.

This parameter configures an input for a torque limit switch. The torque limit switch is used to limit the engine torque. This feature should only be used for temporary protection of equipment. This parameter must be programmed to J1/P1:7 or J1/P1:23 in order to enable this feature.

Table 79

Alternative	Default
“J1/P1:7”, “J1/P1:23”	“NONE”

“Input #5”

MAR99 through JUN01 Personality Modules.

The “Input #5” to the ECM can be used to connect an brake/clutch disable switch. The brake/clutch disable switch is used for applications that require the mobile use of the vehicle with a set engine rpm that does not require the brake or the clutch to disengage the engine rpm set speed. This parameter must be programmed to “Ignore Brake/Clutch Switch” for this feature to be enabled.

Table 80

Alternative	Default
“Ignore Brake/Clutch Switch”	“NONE”

“Ignore Brake/Clutch Switch”

OCT01 and newer Personality Modules.

This parameter configures an input for a brake/clutch disable switch. The “Ignore Brake/Clutch Switch” is used for applications that require the mobile use of the vehicle with a set engine rpm that does not require the brake or the clutch to disengage the engine rpm set speed. This parameter must be programmed to “J1/P1:47” for this feature to be enabled.

Table 81

Alternative	Default
“J1/P1:47”	“NONE”

“Input #6”

MAR99 through JUN01 Personality Modules.

The “Input #6” to the ECM is used to connect the two-speed axle switch. When a two-speed axle is used, the change in gear ratios from the main drive axle ratio to the two-speed axle ratio alters the calibration of the vehicle speed signal. When the parameter is programmed to “Two Speed Axle Switch” and the switch is in the ON position the ECM automatically adjusts the vehicle speed calibration. This will ensure that the ECM driven speedometer and the information that is stored in the ECM correctly reflect the actual vehicle speed.

Table 82

Alternative	Default
“Two Speed Axle Switch”	“NONE”

“Two-Speed Axle Switch”

OCT01 and newer Personality Modules.

This parameter configures an input for a two-speed axle switch. When a two-speed axle is used, the change in gear ratios from the main drive axle ratio to the two-speed axle ratio alters the calibration of the vehicle speed signal. When the parameter is programmed to “J1/P1:6” and the switch is in the ON position the ECM automatically adjusts the vehicle speed calibration. This will ensure that the ECM driven speedometer and the information that is stored in the ECM correctly reflect the actual vehicle speed.

Table 83

Alternative	Default
“J1P1:6”	“NONE”

“Input #7”

JUL99 through JUN01 Personality Modules.

A PTO engine rpm set speed A switch or a diagnostic enable switch can be connected to “Input #7”. If the parameter is programmed to “Diagnostic Enable”, the switch is used to prompt diagnostic flash codes. If the parameter is programmed to “PTO Engine RPM Set Speed Input A”, the switch is used to control engine speed during PTO operation. The “PTO Configuration” parameter must be programmed to “Cab Switches”, “Remote Switches” or “Remote Throttle” and the “PTO Engine RPM Speed Input A” parameter must be programmed to a valid speed.

Table 84

Alternatives	Default
“Diagnostic Enable”, “PTO Engine RPM Set Speed Input A”	“NONE”

“Diagnostic Enable”

OCT01 and newer Personality Modules.

This parameter configures an input for a diagnostic enable switch. The diagnostic enable switch is used to retrieve diagnostic flash codes. Set this parameter to “J1/P1:46” if a switch is wired to this input. Set this parameter to “J1939 Body Controller”, “J1939 Cab Controller”, or “J1939 Instrument Cluster” if a J1939 message is used.

Table 85

Alternative	Default
J1/P1:46 "J1939 Body Controller" "J1939 Cab Controller" "J1939 Instrument Cluster"	"NONE"

"PTO Engine RPM Set Speed Input A"

OCT01 and newer Personality Modules.

This parameter configures an input for a PTO engine rpm set speed A switch. This switch is used to control engine speed during PTO operation. The "PTO Configuration" parameter must be programmed to "Cab Switches", "Remote Switches" or "Remote Throttle" and the "PTO Engine RPM Set Speed A" parameter must be programmed to a valid speed.

Table 86

Alternative	Default
"J1P1:46"	"NONE"

"Input #19"

JUL99 through JUN01 Personality Modules.

The PTO engine rpm set speed B switch can be connected to "Input #19". If the "Input #19" parameter is programmed to "PTO Engine RPM Set Speed Input B", the switch is used to control engine speed during PTO operation. The "PTO Configuration" parameter must be programmed to "Cab Switches", "Remote Switches" or "Remote Throttle" and the "PTO Engine RPM Speed Input B" parameter must be programmed to a valid speed.

Table 87

Alternatives	Default
"PTO Engine RPM Set Speed Input B"	"None"

"PTO Engine RPM Speed Input B"

OCT01 and newer Personality Modules.

This parameter configures an input for a PTO engine rpm set speed B switch. This switch is used to control engine speed during PTO operation. The "PTO Configuration" parameter must be programmed to "Cab Switches", "Remote Switches" or "Remote Throttle" and the "PTO Engine RPM Set Speed B" parameter must be programmed to a valid speed.

Table 88

Alternatives	Default
"J1/P1:7", "J1P1:23"	"None"

"PTO Engine Shutdown Switch"

OCT01 and newer Personality Modules.

This parameter configures an input to use for a engine shutdown switch. The switch will shut down the engine when the engine is in PTO mode and there is no vehicle speed.

Table 89

Alternatives	Default
"J1/P1:7", "J1P1:23"	"None"

"Cruise Control On/Off Switch"

OCT01 and newer Personality Modules.

This parameter configures an input for a cruise control on/off switch. Set this parameter to "J1/P1:59" if a switch is wired to this input. Set this parameter to "J1939 Body Controller", "J1939 Cab Controller", or "J1939 Instrument Cluster" if a J1939 message is used.

Table 90

Alternative	Default
"J1939 Body Controller" "J1939 Cab Controller" "J1939 Instrument Cluster"	"J1/P1:59"

"Cruise Control Set/Resume Switch"

OCT01 and newer Personality Modules.

This parameter configures an input for a cruise control set/resume switch. Set this parameter to "J1/P1:35 & 44" if a switch is wired to this input. Set this parameter to "J1939 Body Controller", "J1939 Cab Controller", or "J1939 Instrument Cluster" if a J1939 message is used.

Table 91

Alternative	Default
"J1939 Body Controller" "J1939 Cab Controller" "J1939 Instrument Cluster"	"J1/P1:35 & 44"

"Cruise Control Pause Switch"

OCT01 and newer Personality Modules.

This parameter configures an input for use as a cruise control pause switch. This functionality is only available for use over a J1939 data link. This feature affects cruise control, elevated idle, and PTO operation.

Table 92

Alternative	Default
"J1939 Body Controller" "J1939 Cab Controller" "J1939 Instrument Cluster"	"NONE"

"A/C High Pressure Switch"

OCT01 and newer Personality Modules.

This parameter determines if the high pressure switch for the air conditioning system will control the output for the cooling fan. When this parameter is programmed to "J1/P1:41", the ECM will turn on the cooling fan when the high pressure switch opens.

Table 93

Alternatives	Default
"None"	"J1/P1:41"

"A/C Fan Request Switch"

Note: This feature is only available when "Truck Manufacturer" is programmed to "GMT-560".

OCT01 and newer Personality Modules.

This parameter configures the cooling fan to start when the clutch for the air conditioning compressor is engaged.

Table 94

Alternatives	Default
"J1/P1:41"	"J1/P1:62"

"Vehicle Speed Input"

The ECM has an input circuit that can be used to receive vehicle speed information. The ECM input can receive the vehicle speed information in either of the following ways:

- A vehicle speed sensor can be connected to the input.
- A signal wire from an electronic control can be connected to the input.

The "Vehicle Speed Input" parameter must be programmed to "J1/P1:32 & 33" to use this option.

The ECM can also be configured to receive vehicle speed information from an Electronic Transmission Control Unit via the J1939 data link. The transmission must be capable of supporting the "J1939 ETC1 Broadcast Message". The "Vehicle Speed Input" must be programmed to "J1939-Trans".

The ECM can also be configured to receive vehicle speed information from the ABS system via the J1939 data link. The ABS system must be capable of supporting the "J1939 High Resolution Wheel Speed Broadcast Message". The "Vehicle Speed Input" must be programmed to "J1939-ABS". The "J1939-ABS" option is only available with OCT01 and newer Personality Modules .

Table 95

Alternative	Default
"J1939-Trans" "J1939-ABS"	"J1/P1:32 & 33"

"Fan Override Switch"

OCT01 and newer Personality Modules.

This parameter selects the J1939 source that will broadcast a switch position in order to override the fan control. When the fan override switch is activated, the ECM will receive a J1939 message. The ECM will disregard all other parameters for fan control and the ECM will turn on the fan.

Table 96

Alternative	Default
"J1939 Body Controller" "J1939 Cab Controller" "J1939 Instrument Cluster"	"NONE"

"Service Brake Pedal Position Switch #1"

OCT01 and newer Personality Modules.

This switch input is required. A switch can be wired to this input or a J1939 message may be used as an input.

Table 97

Alternative	Default
"J1939 Body Controller" "J1939 Cab Controller" "J1939 Instrument Cluster"	"J1/P1:45"

"Clutch Pedal Position Switch"

OCT01 and newer Personality Modules.

This switch input is required for some transmission styles. A switch can be wired to this input or a J1939 message may be used as an input.

Table 98

Alternative	Default
"J1939 Body Controller" "J1939 Cab Controller" "J1939 Instrument Cluster"	"J1/P1:22"

i01727522

Maintenance Parameters

SMCS Code: 1901

"Maintenance Indicator Mode"

The ECM records data that is related to the vehicle's maintenance. If "Distance" is selected, all maintenance indications on the service tool will be displayed in distance. Typical maintenance indications are "PM 1", "PM 2" and the "Coolant Flush/Fill".

If "Hour" is selected, all maintenance indications on the service tool will be displayed in Hours. Typical maintenance indications are "PM 1", "PM 2" and the "Coolant Flush/Fill". The ECM provides "PM 1" maintenance interval and last maintenance information.

Table 99

Alternative	Default
Manual Distance Manual Hours Automatic Distance Automatic Hours	OFF

Note: When the "Truck Manufacturer" parameter is programmed to "GMT-560", "Automatic Distance" is the default setting.

"PM 1 Interval (Manual Maintenance Indicator Mode)"

The "PM 1 Interval" allows a maintenance interval ("PM 1") to be specified by the user. This parameter ("PM 1 Interval") must be programmed only when the Maintenance Indicator Mode is programmed to a Manual Mode (Distance or Hours).

Table 100

Manual Distance		
Minimum	Maximum	Default
8047 km (5000 miles)	56327 km (35000 miles)	24140 km (15000 miles)

Table 101

Manual Hours		
Minimum	Maximum	Default
100	750	250

"PM1 Engine Oil Capacity (Automatic Maintenance Indicator Mode)"

The "PM 1 Interval" can be determined by the ECM. The ECM bases the "PM 1 Interval" on fuel usage. This parameter ("PM 1 Interval") must be programmed only when the Maintenance Indicator Mode is programmed to an Automatic Mode (Distance or Hours). Capacity of the sump influences the maintenance interval.

Table 102

Manufacturer	Minimum	Maximum	Default
GM	19 L (20 qt)	57 L (60 qt)	21 L (22 qt)
Other	19 L (20 qt)	57 L (60 qt)	31 L (33 qt)

OCT01 and newer Personality Modules.

Table 103

Manufacturer / Model	Minimum	Maximum	Default
GM 530/540	19 L (20 qt)	57 L (60 qt)	21 L (22 qt)
GMT-560	19 L (20 qt)	57 L (60 qt)	28 L (30 qt)
Other	19 L (20 qt)	57 L (60 qt)	31 L (33 qt)

i01728725

Output Selections

SMCS Code: 1901

"Output #9"

OCT98 through JUN01 Personality Modules.

"Output #9" can be used to connect a fast idle lamp or a wait to start lamp.

If "Output #9" is programmed to "Fast Idle Lamp", the output will turn on when fast idle operation is active. This requires the "Fast Idle RPM #1" parameter to be programmed to a value above low idle and a momentary switch to be installed on input 18.

If the “Output #9” parameter is programmed to “Wait to Start Lamp”, the output will turn on when the air inlet heater is on and the engine is not running.

Table 104

Manufacturer	Alternative	Default
GM	N/A	N/A
Other	“Wait to Start Lamp”	“Fast Idle Lamp”

When the “Truck Manufacturer” parameter is programmed to “GM” the “Output #9” (Warning Lamp) is used with the standard Caterpillar Engine Monitoring system. With SEP00 and newer Personality Modules, “Output #9” can be configured to only activate when the ECM detects high engine coolant temperature. The “Engine Monitoring Lamps” parameter can be programmed to “Warning Lamp” for normal operation with the Engine Monitoring system. This is the default option. The “Engine Monitoring Lamps” parameter can also be programmed to the “High Coolant Temp Warning Lamp” option. In this configuration, the ECM will only provide an indication of high coolant temperature. This setting allows the ECM to interface with the Vehicle Shutdown System. When this setting is used, the warning lamp will not be available for normal use with the Caterpillar Engine Monitoring System.

When the ECM is configured for the “High Coolant Temp Warning Lamp” option, the output for the warning lamp (terminal 29) will be connected to the vehicle shutdown module. The ECM will provide a ground path at terminal 29, if a high coolant temperature is detected. If a ground path is present at the ECM output for the warning lamp (terminal 29), the vehicle shutdown module will disrupt keyswitch power to the ECM. This will cause the engine to shut down. The ECM will only pull terminal 29 to ground when all of the following conditions are present:

- “Truck Manufacturer” parameter is programmed to “GM”.
- “Engine Monitoring Mode” parameter is not programmed to “OFF”.
- “Engine Monitoring Lamps” parameter is programmed to “High Coolant Temp Warning Lamp”.
- The engine has been running for a minimum of 30 seconds.
- The coolant temperature sensor circuit has no open circuit faults that are active.

- The coolant temperature sensor circuit has no short circuit faults that are active.
- The coolant temperature is at 113 °C (235 °F) or above 113 °C (235 °F) for four seconds.

Note: If the circuit for terminal 29 is shorted to ground in the wiring harness, the vehicle shutdown module will shut down the engine.

After a ground has been detected for two seconds, the vehicle shutdown module will alert the driver of an impending shutdown. A “Check Gauges” message and an audible tone will be present for approximately 25 seconds. A second tone will then sound when the vehicle shutdown module removes keyswitch power from the ECM input. When the keyswitch power is removed from the ECM input, the engine will shut down.

Note: When the “High Coolant Temp Warning Lamp” feature is utilized, the other Caterpillar engine monitoring features are not available to shut down the engine. The vehicle shutdown module may provide similar functions.

“Fast Idle Enabled Lamp”

OCT01 and newer Personality Modules.

This parameter configures the ECM to turn on a lamp that is connected to output J1/P1:31 or to output J1/P1:21 when fast idle operation is active. To use this feature, a momentary switch must be connected to input #18 (J1/P1:40) and the parameter “Fast Idle RPM #1” must be programmed to a valid speed that is above low idle.

Table 105

Manufacturer / Model	Alternatives	Default
Other	“J1/P1:21” “NONE”	“J1/P1:31”
GMT-560	“J1/P1:31” “NONE”	“J1/P1:21”

“Wait To Start Lamp”

Note: This feature is only available when “Truck Manufacturer” is programmed to “Other”.

This parameter configures the ECM to turn on a lamp that is connected to output J1/P1:31 when the air inlet heater is on and the engine is not running. “Fast Idle Enabled Lamp” must be programmed to “J1/P1:21” for this feature to be used.

Table 106

Alternatives	Default
“J1/P1:31”	“NONE”

“PTO Switch On Lamp”

OCT01 and newer Personality Modules.

This parameter configures the ECM to turn on a lamp that is connected to output J1/P1:30 when the engine is in PTO mode.

Table 107

Alternatives	Default
“NONE”	“J1/P1:30”

“Change Oil Lamp”

OCT01 and newer Personality Modules.

This parameter configures the ECM to turn on a lamp that is connected to output J1/P1:30 when the programmed maintenance parameters indicate that an oil change is needed.

Table 108

Alternatives	Default
“NONE”	“J1/P1:30”

“Fan Control Type”

Personality Modules prior to JUN01.

If the ECM is used to operate the cooling fan, this parameter must be programmed to the “On/Off”. This parameter should be programmed to “NONE” if the ECM is not connected to the cooling fan relay or the cooling fan solenoid. Also, this parameter should be programmed to “NONE” if the ECM is not operating the cooling fan relay or the cooling fan solenoid. When this parameter is programmed to “NONE”, the service technician can use Cat ET to determine that the ECM is not connected to the fan circuit.

Table 109

Alternative	Default
“On/Off”	“NONE”

“Fan Control Type”

OCT01 and newer Personality Modules.

If the ECM is used to operate the cooling fan, this parameter must be programmed to the “On/Off” or one of the optional parameters. This parameter should be programmed to “NONE” if the ECM is not connected to the cooling fan relay or the cooling fan solenoid. Also, this parameter should be programmed to “NONE” if the ECM is not operating the cooling fan relay or the cooling fan solenoid. When this parameter is programmed to “NONE”, the service technician can use Cat ET to determine that the ECM is not connected to the fan circuit.

Table 110

Manufacturer / Model	Alternative	Default
GM	“On/Off” “Variable Speed Option S”	“NONE”
GMT-560	“On/Off” “On/Off Option B” “Variable Speed Option B25” “Variable Speed Option B27” (1)	
Other	“On/Off” “Variable Speed Option S”	

(1) All of the “B options” are not available with the OCT01 software release.

“Engine Running Output”

Note: This feature is only available when “Truck Manufacturer” is programmed to “GMT-560”.

OCT01 and newer Personality Modules.

This parameter configures the ECM to control a solenoid or a relay in order to prevent the starter motor from being engaged after the engine has started.

Table 111

Alternative	Default
“J1/P1:31”	“NONE”

“Starting Aid Output”

OCT01 and newer Personality Modules.

This parameter is used to allow the ECM to determine if conditions are correct for the use of a starting aid (ether).

Table 112

Alternative	Default
“Automatic”	“OFF”

i01728841

Passwords

SMCS Code: 1901

“Customer Password #1”

“Customer Password #1” is a password that is assigned by the customer. The “Customer Password #1” is eight digits in length. A customer password is required to change any of the customer specified parameters.

“Customer Password #2”

“Customer Password #2” is an additional eight digits that will decrease the possibility of breaking the customer password. This is an optional password.

Table 113

Alternative	Default
“Eight Alphanumeric Characters Available”	“Not Programmed”

i01726757

Selected Engine Rating

SMCS Code: 1901

“Rating Number”

The Rating Number is the selected Rating within a power rating family. The Personality Module defines the power rating family (224 kW (300 hp)) and the personality module may contain only one or several ratings. The rating number defines the power rating that is used within the power rating family.

ECM Identification Parameters

“Vehicle ID”

“Vehicle Identification” is the identification of the vehicle that is assigned by the customer. “Vehicle Identification” is used only for the customer’s reference. “Vehicle Identification” is not required by the ECM.

i01727431

Smart Idle Parameters

SMCS Code: 1901

“Battery Monitor & Engine Control Voltage”

OCT01 and newer Personality Modules.

This parameter sets a voltage trip point. When the voltage falls below the trip point the ECM will automatically elevate the engine speed to the rpm that is specified in the “Battery Monitor & Low Idle Engine Speed” parameter.

Table 114

Manufacturer / Model	Minimum	Maximum	Default
GM 530/540	0 Volts	25.5 Volts	0 Volts
GMT-560			11.5 Volts
Other			0 Volts

“Battery Monitor Low Idle Engine Speed”

OCT01 and newer Personality Modules.

This parameter sets the engine speed if the battery voltage falls below the trip point that is specified in the “Battery Monitor & Engine Control Voltage” parameter.

Table 115

Minimum	Maximum	Default
700 rpm	TEL	1000 rpm

i01727555

Trip Parameters

SMCS Code: 1901

“Dash - PM 1 Reset”

This parameter determines if the Caterpillar Driver Information Display (Cat ID) can be used to reset the PM 1 Maintenance Interval. The “Maintenance Indicator Mode” cannot be programmed to “OFF” for the PM 1 reset parameter to take effect.

Table 116

Alternative	Default
“YES”	“NO”

OCT01 and newer Personality Modules.

Table 117

Manufacturer / Model	Alternatives	Default
GM 530/540	“YES”	“NO”
GMT-560	“NO”	“YES”
Other	“YES”	“NO”

“Dash - Customer Parameters”

Four parameters can be accessed when this parameter is programmed to “YES”. The Cat ID is used to change the “Dash - Customer” parameters. The following four parameters can be accessed:

- “SoftCruise Control”
- “Fast Idle RPM #1”
- “Fast Idle RPM #2”
- “Low Idle Engine RPM”

Each parameter that is listed has a “YES/NO” option with “NO” as the default. The Cat ID must have the EEPROM chip that is capable of communicating with the 3126B HEUI engine software. Version 1.3 and later versions meet this requirement.

Table 118

Alternative	Default
“YES”	“NO”

“Theft Deterrent System Control”

When this parameter is used with a “Theft Deterrent Password”, this parameter prevents the engine from starting unless the password has been entered via the dash display of the CAT ID. Before the operator can use the feature of theft deterrent of the CAT ID, the system must be turned on. In order to turn on the theft deterrent, a service tool must be used to program the parameter for the theft deterrent to YES. The operator must first enter the password before the engine is shut off. This will enable the system. Enabling the system prevents the engine from starting without re-entering the password on the next attempted start. If this parameter is programmed to the “Auto-Enable” option, the system will automatically be armed when the keyswitch is turned off.

Note: The “Auto-Enable” feature requires a JUL99 or more recent Personality Module with a Cat ID (version number 2.1 or higher).

Table 119

Alternative	Default
“YES”, “Auto-Enable”	“NO”

“Theft Deterrent Password”

The “Theft Deterrent Password” is the password that is required by the ECM before the feature of theft deterrent is enabled. After the theft deterrent is enabled, the “Theft Deterrent Password” is the password that is required to restart the engine. All of the characters must be uppercase. Four characters are available for the password. If the password is lost, a service tool and a factory password are required in order to start the engine.

Table 120

Alternative	Default
Four Characters A through Z 0 through 9	0000

“Quick Stop Rate”

This parameter determines the rate of vehicle speed change that is used by the ECM to record a Quick Stop Event Code and a quick stop snapshot. Programming this parameter to 0 will disable this feature and no quick stop events will be logged. Each quick stop snapshot contains 60 frames of information. Frame 45 is the quick stop event. The quick stop snapshot also contains 44 frames before the quick stop event and 15 frames after the quick stop event. Each frame is separated by 1.0 second.

Table 121

ECM Snapshot Frame Data	
“Engine rpm” “Throttle Position” “Clutch Switch”	“Vehicle Speed” “Cruise Status” “Brake Switch”

The most recent quick stop snapshot is stored in the ECM memory. When a quick stop event occurs the ECM replaces the old quick stop snapshot with the new quick stop snapshot. The ECM also logs a diagnostic event code for each quick stop event. The ECM stores a maximum of 255 occurrences.

Table 122

Alternative	Default
0 kilometers per hour per second (0 miles per hour per second) to 205 kilometers per hour per second (128 miles per hour per second)	0 kilometers per hour second (0 miles per hour per second)

Note: Programming the “Quick Stop Rate” too low will cause an excessive number of Quick Stop Event Codes. A vehicle without a load or a trailer will be able to stop much more quickly than a vehicle with a heavy load. If too many Quick Stop Event Codes are being logged, the “Quick Stop Rate” should be increased. This will improve the detection of the exceptions when the exceptions occur.

i01726787

Truck Manufacture Parameters

SMCS Code: 1901

“Truck Manufacturer”

OCT01 and newer Personality Modules.

This parameter is used to configure the correct set of options and/or ranges for the default parameter for the application. The 3126B truck engine with serial number prefix 7AS is equipped with a Basic ECM or the 3126B truck engine is equipped with a Full Feature ECM. The Personality Module software will depend on the vehicle application. The option for the “Truck Manufacturer” parameter is set at the factory to provide the same functionality with one ECM and one set of Personality Module software. If an ECM replacement is required, the “Truck Manufacturer” parameter must be programmed before programming other customer parameters in order to configure the proper set of defaults/ranges. When a Basic ECM is replaced in a General Motors chassis, program the “Truck Manufacturer” parameter to the GM option. When a Full Feature ECM is replaced on an engine in any other chassis, program the “Truck Manufacturer” parameters to “Other”.

Table 123

Alternative	Default
“GM”, “Other”	“Not Programmed”

“Truck Model Type”

OCT01 and newer Personality Modules.

This parameter is used to configure the correct set of options and/or ranges for the default parameter for the application. The option for the “Truck Model Type” parameter is set at the factory. If an ECM replacement is required, the “Truck Model Type” parameter must be programmed before programming other customer parameters in order to configure the proper set of defaults/ranges. When the software is flashed into the Personality Module, this parameter will default to “GM 530/540”.

Table 124

Alternative	Default
“GMT-560”	“GM530/540”

i01727228

Timer Parameters

SMCS Code: 1901

“Idle Shutdown Time”

The “Idle Shutdown Time” is the time (minutes) of engine idle before shutting down. The engine will only shut down if the ECM senses low engine load and no vehicle speed. The “Idle Shutdown Time” will not begin counting if the engine is in Cold Mode. If this parameter is programmed to zero, this feature is disabled and the engine will idle until the keyswitch for the ignition is in the OFF position.

Note: This feature does not shut down the vehicle’s power. The ECM and the vehicle remain powered.

Table 125

Minimum	Maximum	Default
3 minutes	1440 minutes	0 minutes

“Allow Idle Shutdown Override”

This parameter determines if the clutch or the service brake can be used to override the idle shutdown timer during the driver alert. The driver alert is the last 90 seconds when the check engine lamp begins flashing. This parameter requires the “Idle Shutdown Time” to be programmed to a 3 or more minutes for the parameter to be enabled. When the “Idle Shutdown Time” is programmed to 0, the parameter is turned off.

Table 126

Alternative	Default
“NO”	“YES”

“A/C Switch Fan-On Time”

Input 11 to the ECM can be used for the connection of a normally closed high pressure A/C switch. The ECM has a built-in timer. The timer is used to prevent excessive cycling of the cooling fan clutch due to successive cycling of the A/C switch. Programming this parameter to 0 disables the function. Programming depends on the refrigerant, and the design of the air conditioning system as well as the use of the signal input. Program the timer to 1 second for the connection of this input to another system. Programming the timer to 1 second also provides a time delay. This feature requires the "Fan Control Type" parameter to be programmed to "On/Off" or to "Variable Speed Fan Option S". Also, the "A/C High Pressure Switch" parameter must be programmed to "J1/P1:41" or to "J1/P1:62" for GMT-560.

Table 127

Manufacturer	Minimum	Maximum	Default
GM	N/A	N/A	N/A
Other	0 seconds	600 seconds	0 seconds

OCT01 and newer Personality Modules.

Table 128

Minimum	Maximum	Default
0 second	600 seconds	0 seconds

"Fan with Engine Brake On"

This parameter determines whether the cooling fan will turn on when the engine brake has been active for at least two seconds. This feature requires the "Fan Control Type" parameter to be programmed to "On/Off". An on/off fan must also be installed in order for this option to be functional.

Table 129

Manufacturer	Alternatives	Default
GM	N/A	N/A
Other	"YES"	"NO"

OCT01 and newer Personality Modules.

Table 130

Alternatives	Default
"YES"	"NO"

"Exhaust Brake Configuration"

OCT01 and newer Personality Modules.

This parameter determines the functionality of the exhaust brake. The exhaust brake can be programmed only as an exhaust brake to aid in slowing the vehicle or the exhaust brake can be programmed to put a load on the engine in order to warm up the engine faster.

Table 131

Manufacturer/ Model	Alternatives	Default
GM 530/540	"None" "Exhaust Brake Only"	"Exhaust Brake Only"
GMT-560	"Warm Up" "Exhaust Brake & Warm Up"	"None"
Other		"Exhaust Brake Only"

"Warm Up Mode Idle Speed"

OCT01 and newer Personality Modules.

This parameter determines the idle speed of the engine until the engine reaches operating temperature.

Table 132

Minimum	Maximum	Default
700 rpm	1400 rpm	1000 rpm

i01726906

Vehicle Speed Parameters

SMCS Code: 1901

"Vehicle Speed Calibration"

This calibration is used when the ECM is configured to use a vehicle speed sensor that is connected to the ECM vehicle harness connector J1/P1:32 & 33.

The "Vehicle Speed Calibration" is the value that is used by the ECM in order to translate the vehicle speed signal into kilometers per hour (miles per hour). When a vehicle speed sensor is connected to an ECM input, the "Vehicle Speed Input" must be programmed to "J1/P1:32 & 33". This parameter is programmed in pulses per kilometer (PPKM) or pulses per mile (PPM). This parameter must be programmed. If this parameter is not programmed, 253-02 Check Customer or System Parameters (56) will become active. This parameter affects the cruise control and the ECM speedometer signal. Also, this parameter can affect the PTO operation, extended idle and trip totals.

Table 133

Manufacturer	Minimum	Maximum	Default
GM	2485 PPKM (4000 PPM)	238080 PPKM (384000 PPM)	19884 PPKM (32000 PPM)
Other	2485 PPKM (4000 PPM)	238080 PPKM (384000 PPM)	"Not Programmed"

“Vehicle Speed Cal (J1939-Trans)”

The “Vehicle Speed Cal (J1939-Trans)” is used when the ECM is configured to use the speed of the transmission output shaft in order to calculate vehicle speed. The “Vehicle Speed Input” parameter must be programmed to “J1939-Trans”. This value represents the revolution of the transmission output shaft as revolutions per kilometer (revolutions per mile). This parameter must be programmed. If this parameter is not programmed, 253-02 Check Customer or System Parameters (56) will become active. This parameter affects the cruise control and the ECM speedometer signal. Also, this parameter can affect the PTO operation, extended idle and trip totals.

Table 134

Minimum	Maximum	Default
0 revolutions per km (0 revolutions per mile)	43000 revolutions per km (65000 revolutions per mile)	"Not Programmed"

“Vehicle Speed Cal (J1939 ABS)”

OCT01 and newer Personality Modules.

The “Vehicle Speed Cal (J1939-ABS)” is used to calculate vehicle speed by using the input from the wheel speed. The data from the wheel speed is transmitted via the J1939 data link. The “Vehicle Speed Input” parameter must be programmed to “Vehicle Speed Cal J1939-ABS”. The manufacturer of the ABS system must transmit tire revolutions per mile that is based on the tire size. If the tire size is changed from tire size that is programmed in the ABS system, the “Vehicle Speed Cal (J1939-ABS)” must be changed. The value that is contained in the “Vehicle Speed Cal (J1939-ABS)” parameter is a ratio. If the actual tire size is equal to the tire size that is programmed in the ABS system, the “Vehicle Speed Cal (J1939-ABS)” parameter will be “1”. The ratio can be found by dividing the tire revolutions per mile that is transmitted by the ABS system by the actual tire revolutions per mile. Contact the manufacturer of the ABS system in order to verify that this message is supported.

If the “Vehicle Speed Input” parameter is programmed to “Vehicle Speed Cal J1939-ABS”, this parameter must be programmed. If this parameter is not programmed, 253-02 Check Customer or System Parameters (56) will become active. This parameter affects the cruise control and the ECM speedometer signal. Also, this parameter can affect the PTO operation, extended idle and trip totals.

Table 135

Minimum	Maximum	Default
0	6.550	"Not Programmed"

“Vehicle Speed Limit (VSL)”

The “Vehicle Speed Limit” (VSL) is the maximum vehicle speed that is allowed by the ECM. The ECM will shut off fuel above this speed. An inexperienced driver may think that something is wrong with the engine because the ECM will not fuel the engine above this vehicle speed limit. Vehicle speed limiting allows the implementation of a gear fast/run slow specification for the truck. The gear fast/run slow specification for the truck improves fuel economy while the parameter for the vehicle speed limit limits the maximum vehicle speed of the truck.

Table 136

Manufacturer	Minimum	Maximum	Default
GM	48 km/h (30 mph)	121 km/h (75 mph)	121 km/h (75 mph)
Other	48 km/h (30 mph)	204 km/h (127 mph)	204 km/h (127 mph)

“VSL Protection”

The “VSL Protection” is the maximum engine rpm when there is a problem with the vehicle speed signal that is detected by the ECM. The ECM limits the engine to this engine rpm when the ECM senses no vehicle speed signal, and a load on the engine. This is a feature that is used to prevent tampering by running without a Vehicle Speed input to the ECM.

Note: When this parameter is programmed to the TEL rpm, the ECM disables 84-01 Loss Of Vehicle Speed Signal (31) and 84-10 Vehicle Speed Rate of Change (36) and the “VSL Protection” may be exceeded by disconnecting the vehicle speed sensor.

Table 137

Manufacturer	Minimum	Maximum	Default
GM	“1700 rpm”	“1700 rpm”	“1700 rpm”
Other	1700 rpm	TEL rpm	TEL rpm

“Tachometer Calibration”

The “Tachometer Calibration” is used by the ECM to translate the engine speed signal into revolutions per minute for a tachometer. The “Tachometer Calibration” is programmed in pulses per revolution (PPR). The programmable range is from 2.0 to 500.0 in increments of 0.1 PPR.

Table 138

Manufacturer	Minimum	Maximum	Default
GM	2.0 PPR	500.0 PPR	17.5 PPR
Other	2.0 PPR	500.0 PPR	134.0 PPR

“Soft Vehicle Speed Limit”

The “Soft Vehicle Speed Limit” operates in conjunction with the “Vehicle Speed Limit”. The “Soft Vehicle Speed Limit” limits the vehicle speed within the following range:

- The minimum value is 4 km/h (2.5 mph) below the programmed “Vehicle Speed Limit” at full load.
- The maximum value is 4 km/h (2.5 mph) above the selected “Vehicle Speed Limit” at no load.

Table 139

Manufacturer	Alternative	Default
All Applications	“NO”	“YES”

“Low Speed Range Axle Ratio”

MAR98 and newer Personality Modules.

The “Low Speed Range Axle Ratio” parameter must be programmed when an on/off switch for the two-speed axle is used by the ECM to adjust the vehicle speed calibration. When a two-speed axle is used, the change in gear ratios from the high speed range to the low speed range alters the calibration of the vehicle speed signal. Since the vehicle speed signal has been altered, a calibration adjustment is required to ensure that the ECM driven speedometer and the information that is stored in the ECM correctly reflect the actual vehicle speed. This parameter should be programmed to the “Low Speed Range Axle Ratio”. This parameter only requires programming when the “Two-Speed Axle Switch” parameter is enabled.

Table 140

Minimum	Maximum	Default
0.00	19.99	0.00

“High Speed Range Axle Ratio”

This parameter only requires programming when the “Two-Speed Axle Switch” parameter is enabled. The “High Speed Range Axle Ratio” must be programmed when an on/off switch for the two-speed axle is used by the ECM to adjust the vehicle speed calibration. When a two-speed axle is used, the change in gear ratios from the high speed range to the low speed range alters the calibration of the vehicle speed signal. Since the vehicle speed signal has been altered, a calibration adjustment is required to ensure that the ECM driven speedometer and the information that is stored in the ECM correctly reflect the actual vehicle speed. This parameter should be programmed to the “High Speed Range Axle Ratio”.

Table 141

Minimum	Maximum	Default
0.00	9.99	“0.00”

System Configuration Parameters

i01182873

System Configuration Parameters

SMCS Code: 1901

System Configuration Parameters affect the emissions of the engine or the power of the engine. System Configuration Parameters are programmed at the factory. System Configuration Parameters would never need to be changed through the life of the engine normally. System Configuration Parameters must be reprogrammed if an ECM is replaced. Unless the engine rating has changed, System Configuration Parameters do not need to be reprogrammed when the Personality Module is replaced. Proper values for these parameters are stamped on the engine information ratings plate. The engine information ratings plate is located on the valve cover or the air inlet manifold. Factory Passwords are required to change these parameters. The following information is a description of the System Configuration Parameters.

“Full Load Setting”

“Full Load Setting” is a number that represents the adjustment to the fuel system that was made at the factory in order to fine tune the fuel system. The correct value for this parameter is stamped on the engine information ratings plate. A new ECM requires this parameter to be programmed to avoid generating a 253-02 Check Customer Or System Parameters (56) Diagnostic Code.

“Full Torque Setting”

“Full Torque Setting” is similar to “Full Load Setting”. This parameter must be programmed to avoid generating a 253-02 Check Customer Or System Parameters (56) Diagnostic Code.

Personality Module Code

The Personality Module Code is a code that prevents the use of an incorrect personality module for this engine. Each horsepower family and each emission certification has a different code that is associated with the horsepower family or the emission certification.

When a personality module is replaced this code must match the code that is stored in the ECM. If the personality module code does not match the code that is stored in the ECM, both of the following situations will exist:

- The engine will only run at low idle.
- A 253-02 Check Customer Or System Parameters (56) Diagnostic Code will also be generated.

Note: The flash programming of a personality module replaces the personality module.

When the engine is being rerated, programming this code to 0 will prompt the ECM to read the stored code and programming this code to 0 will prompt the ECM to match the stored code to the Personality Module Code. This code does not need to be programmed when a personality module is replaced under both of the following conditions:

- The new personality module is from the same family.
- The new personality module is from the same emission year.

If the Personality Module is from a different family, the following components may need to be changed: pistons, injectors, and other components. The engine information ratings plate must also be changed in order to reflect the new rating.

Some vehicle systems such as the cooling system or the transmission may also require changes when the engine is rerated. Please contact the local OEM dealer for further information.

“Engine Serial Number”

The “Engine Serial Number” should be programmed to match the engine serial number that is stamped on the engine information plate. When a new ECM is delivered, the engine serial number in the ECM is not programmed.

“Personality Module Release Date”

This parameter is defined by the Personality Module and this parameter is not programmable. The “Personality Module Release Date” is used to provide the version of the software. The Customer parameters and the software change levels can be monitored by this date. The date is provided in the month and the year (NOV99). NOV is the month (November). 99 is the year (1999).

Troubleshooting without a Diagnostic Code

i01858296

Can Not Reach Top Engine RPM

SMCS Code: 7569

Probable Causes

Note: If this problem occurs under load, refer to Troubleshooting, "Low Power/Poor or No Response to Throttle".

The probable root causes are listed in order below:

- Customer Specified Parameters (normal operation)
- Cold Mode operation
- Accelerator pedal position sensor
- Vehicle speed signal
- Fuel Supply
- Dedicated PTO switch on or torque limit switch always on

Recommended Actions

Perform the following diagnostic procedures in order:

Check Customer Specified Parameters

1. Verify that the complaint is not normal operation (programmed parameter).
2. Connect an electronic service tool to the cab data link connector.
3. Check the following parameters:
 - "Vehicle Speed Limit"
 - "Lower Gears Engine RPM Limit"
 - "Intermediate Gears Engine RPM Limit"
 - "Gear Down Protection Engine RPM Limit"
 - "Top Engine Limit"
 - "VSL Protection"

- "PTO Top Engine Limit" with the PTO On/Off Switch turned ON.
- "PTO Vehicle Speed Limit" with the PTO On/Off Switch turned ON.

4. Set each parameter to the parameter's maximum value one at a time and determine whether the problem is corrected.

Check Cold Mode Operation.

Note: This is normal operation if the problem occurs only after start-up in cold weather.

1. Connect the electronic service tool to the cab data link connector.
2. Monitor the electronic service tool in order to verify that the engine has progressed from Cold Mode.

An active Cold Mode is indicated in the upper corner of any status screen.

Check the Accelerator Pedal Position Sensor.

1. Use the Cruise/Idle On/Off switch to put the engine in Idle mode.
2. Vary the engine rpm with the Set/Resume switches.

If both of the following conditions are met, connect the electronic service tool and monitor the status of the accelerator pedal position sensor.

- The engine is stable by using idle mode to control the engine rpm.
- The engine is unstable by using the accelerator pedal position sensor.

If the status of the accelerator pedal position sensor is unstable, refer to Troubleshooting, "Accelerator Pedal (Throttle) Position Sensor Circuit - Test".

Vehicle Speed Signal

Monitor the vehicle speed signal. Ensure the accuracy of the vehicle speed signal by comparing the vehicle speed signal to the actual vehicle speed.

If the vehicle speed is greater than the VSL, the engine rpm is limited to the programmed "VSL Protection". If a problem is discovered, refer to Troubleshooting, "Vehicle Speed and Speedometer Circuit - Test".

Fuel Supply

1. Check the fuel supply.
2. Monitor the exhaust for smoke while the engine is being cranked.

If no smoke is present, there may be a problem with the fuel quality or there may be a problem with the fuel supply.
3. Check the fuel quality. Refer to the Truck Performance and Driveability Diagnostic Guide, LEBT3477.
4. Check the fuel pressure. Refer to Testing and Adjusting, "Fuel System Pressure - Test".
5. Ensure that the fuel system has been primed. Refer to Testing and Adjusting, "Fuel System - Prime".
6. Check for fuel supply lines that are restricted.
7. Check the fuel filters.
8. If the temperature is below 0 °C (32 °F), check for solidified fuel (wax).
9. Check for air in the fuel system. Refer to Testing and Adjusting, "Air in Fuel - Test".

Dedicated PTO Switch On or Torque Limit Switch always On

Check the parameter setting for the Dedicated PTO parameter. If the "Torque Limit" is programmed below 2720 N·m (2000 lb ft) check the status screen for "Input No. 1" and "Input No. 2". Ensure that the status indicates "OFF".

Note: The system is operating correctly if the torque limit is programmed and the status is "On". If the PTO switch is connected to the PTO input and the PTO switch is not switching on or off refer to Troubleshooting, "PTO Switch Circuit - Test".

i01191584

Can Not Reach Vehicle Speed Limit

SMCS Code: 7569

Probable Causes

The probable root causes are listed in order below:

- Customer Specified Parameters (normal operation)
- Cold Mode Operation
- Electronic System problem
- Fuel supply
- Air Inlet System or Exhaust System
- Leakage in Air-to-Air Aftercooler Core

Recommended Actions

Perform the following diagnostic procedures in order:

1. Check Customer Specified Parameters.
 - a. Verify that the complaint is not normal operation (programmed parameter).
 - b. Connect an Electronic Service Tool.
 - c. Check the following parameters:
 - "Vehicle Speed Limit"
 - "Soft Vehicle Speed Limit"
 - "Lower Gears Engine RPM Limit"
 - "Intermediate Gears Engine RPM Limit"
 - "Gear Down Protection Engine RPM Limit"
 - "VSL Protection"
 - "Top Engine Limit"
 - Incorrect programming of the Vehicle Speed calibration (ppm).
 - "PTO Top Engine Limit" with the PTO On/Off Switch turned ON.
 - "PTO Vehicle Speed Limit" with the PTO On/Off Switch turned ON.
 - d. Set each parameter to the parameter's maximum value one at a time and determine whether the problem is corrected.

Note: The "Soft Vehicle Speed Limit" will not allow the vehicle to achieve the programmed VSL under all engine load conditions. Programming the "Soft Vehicle Speed Limit" to NO may be required to eliminate the complaint.

2. Check Cold Mode Operation.

Note: This is normal operation if the problem occurs only after start-up in cold weather.

- a. Connect an Electronic Service Tool.
- b. Monitor the Electronic Service Tool in order to verify that the engine has progressed from Cold Mode.

An Active Cold Mode is indicated in the upper corner of any Status Screen.

3. Check for an Electronic System problem.

- a. Connect an Electronic Service Tool.
- b. Monitor the Fuel Position, the Rated Fuel Limit, and the FRC Fuel Limit.

While the vehicle is operating under full load, the parameters should meet the following conditions:

- The Fuel Position is equal to the Rated Fuel Limit.
- The Fuel Position is less than the FRC Fuel Limit.

If the Fuel Position is equal to the Rated Fuel Limit and the Fuel Position is less than the FRC Fuel Limit, the Electronics are operating correctly. Go to Step 5.

4. If the Fuel Position is not equal to the Rated Fuel Limit and/or the Fuel Position is not less than the FRC Fuel Limit, perform the following tests in order:

- a. Connect an Electronic Service Tool.
- b. When the engine is OFF, turn the Ignition Key Switch to the ON position. Check the boost pressure on an Electronic Service Tool Status Screen.

When the engine is OFF, the boost pressure should be 0 kPa (0 psi).

- c. Monitor the status of the Accelerator Pedal Position Sensor. Operate the engine at high idle with the vehicle in Neutral.

If the engine can not reach the programmed "Top Engine Limit", check the Accelerator Pedal Duty Cycle in order to ensure that the Accelerator Pedal Duty Cycle is within calibration (75 to 90 Percent at high idle).

If the accelerator pedal position is unstable, check the Accelerator Pedal Position Duty Cycle. Check the Accelerator Pedal Position Duty Cycle by slowly operating the accelerator pedal in order to verify that the Accelerator Pedal Position Sensor is within calibration. The Accelerator Pedal Position Sensor is within calibration when both of the following conditions are met:

- 10 to 22 percent at low idle
- 75 to 90 percent at high idle

Also, ensure that the duty cycle changes as the pedal position changes.

If a problem with the Accelerator Pedal Position Sensor is suspected, refer to Troubleshooting, "Accelerator Pedal (Throttle) Position Sensor Circuit - Test".

Note: If the engine exceeds the "Top Engine Limit", the "Top Engine Limit with Droop" is programmed to YES.

5. Monitor the vehicle speed signal. Ensure the accuracy of the vehicle speed signal by comparing the vehicle speed signal to the actual vehicle speed.

If the vehicle speed is greater than the VSL, the Power is limited. If a problem is discovered, refer to Troubleshooting, "Vehicle Speed Circuit - Test".

6. Check the "Power train Data Link". Ensure that the SAE J1922 or the SAE J1939 Power train Data Link is not limiting the power.

- a. Connect an Electronic Service Tool.
- b. Monitor the "Power train Data Link" Status screen while the vehicle is experiencing problems.

If the "Power train Data Link" Status screen indicates that the "Power train Data Link" is limiting the power or the rpm, verify that this is not normal operation. If this is not normal operation, refer to the vehicle OEM for repairs.

7. Check the fuel supply.

- a. Monitor the exhaust for smoke while the engine is being cranked.

If no smoke is present, there may be a problem with the fuel quality or there may be a problem with the fuel supply.

- b. Check the fuel quality. Refer to Testing and Adjusting, "Fuel Quality - Test". Also refer to the Truck Performance and Driveability Diagnostic Guide, LEBT3477.
 - c. Check the fuel pressure. Refer to Testing and Adjusting, "Fuel System Pressure - Test".
 - d. Ensure that the fuel system has been primed. Refer to Testing and Adjusting, "Fuel System - Prime".
 - e. Check for fuel supply lines that are restricted.
 - f. Check the fuel filters.
 - g. If the temperature is below 0 °C (32 °F), check for solidified fuel (wax).
 - h. Check for air in the fuel system. Refer to Testing and Adjusting, "Air in Fuel - Test".
8. Check the Air Inlet System for restrictions or leakage. Check the Exhaust System for restrictions or leakage. Refer to Testing and Adjusting, "Air Inlet and Exhaust System - Inspect".
9. Check for leakage in the Air-to-Air Aftercooler Core . Refer to Testing and Adjusting, "Aftercooler - Test".

i01641503

Check Engine Lamp or Warning Lamp Is Malfunctioning

SMCS Code: 7400; 7569

Probable Causes

The probable root causes are listed in order below:

- Intermittent diagnostic codes
- Check engine lamp
- Warning lamp
- Cruise control set/resume switch
- Short in vehicle harness
- Service engine soon lamp (GM)

Recommended Actions

Note: GM vehicles refer to the Check Engine Lamp as the Service Engine Soon Lamp.

Perform the following diagnostic procedures in order:

Intermittent Diagnostic Codes

Check for logged diagnostic codes and active diagnostic codes with Caterpillar Electronic Technician (ET). Check for any intermittent diagnostic codes.

Check Engine Lamp

1. In order to check the check engine lamp, turn the ignition key to the ON position while the engine is OFF.

The check engine lamp should turn on. Then, the check engine lamp should turn off. The check engine lamp will flash if there is an active diagnostic code.

- a. If the check engine lamp does not operate correctly remove the check engine lamp (terminal 28) from the ECM connector (seventy terminal).
- b. Connect the check engine lamp (terminal 28) to the ground stud. Turn the ignition key switch to the ON position.
- c. Observe the check engine lamp.

If the check engine lamp comes on, check the power connection and the ground connection of the ECM. Refer to Troubleshooting, "Check Engine Lamp Circuit - Test" for additional information.

If the lamp does not come on, check the lamp in order to ensure that the lamp is not burned out. Also, check the wiring in order to ensure that there is not an open circuit.

Warning Lamp

1. In order to check the warning lamp, start the engine.

The warning lamp should come on for at least 2 seconds. Then, the warning lamp should turn off. The warning lamp will remain on or flash if there is a problem with the engine.

- a. If the warning lamp does not operate correctly remove the warning lamp (terminal 29) from the ECM connector (seventy terminal).
- b. Connect the warning lamp (terminal 29) to the ground stud. Turn the ignition key switch to the ON position.
- c. Observe the warning lamp.

If the warning lamp comes on, check the power connection and the ground connection of the ECM. Refer to Troubleshooting, "Warning Lamp Circuit - Test" for additional information.

If the lamp does not come on, check the lamp in order to ensure that the lamp is not burned out. Also, check the wiring in order to ensure that there is not an open circuit.

Cruise Control Set/Resume Switch

Connect ET to the cab data link connector. Observe the status screen for the cruise control set/resume switch.

If the status screen indicates that the switch is on and the switch is not in the ON position, the switch is shorted out. Refer to Troubleshooting, "Cruise Control Switch Circuit - Test".

Short in Vehicle Harness

Check Engine Lamp

Monitor the check engine lamp while the check engine lamp (terminal 28) is removed from the ECM connector (seventy terminal). Also, the technician could monitor the check engine lamp while the ECM connector (P1) is disconnected.

If the lamp remains on and the pin has been removed from the ECM, there is a short circuit to ground in the vehicle harness.

Warning Lamp

Monitor the warning lamp while the warning lamp (terminal 29) is removed from the ECM connector (seventy terminal). Also, the technician could monitor the warning lamp while the ECM connector (P1) is disconnected.

If the lamp remains on and the pin has been removed from the ECM, there is a short circuit to ground in the vehicle harness.

Service Engine Soon Lamp (GM)

Check the ALDL Connector in order to ensure that there is not a short circuit between electrical terminal 4 and electrical terminal 6 or between electrical terminal 5 and electrical terminal 6.

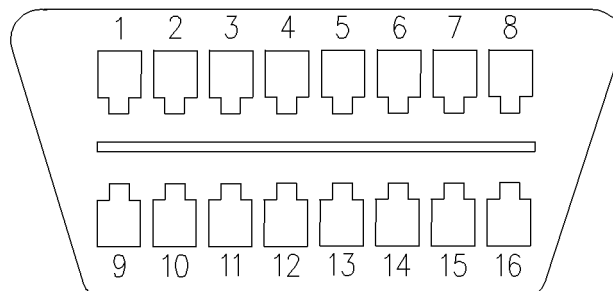

Illustration 17

g00849286

GM ALDL cab connector.

- (4) BAT Negative
- (5) BAT Negative
- (6) Diagnostic Enable
- (7) J1587 Data Link Positive
- (15) J1587 Data Link Negative
- (16) BAT Positive

i01641517

Cruise Control, Idle, or PTO Can Not Be Set

SMCS Code: 1408; 1901

Probable Causes

The probable root causes are listed in order below:

- Customer Specified Parameters (normal operation)
- On/Off switch for cruise control and idle control
- ET status screen

Recommended Actions

Perform the following diagnostic procedures in order:

Customer Specified Parameters

When cruise control or idle control is set by using the cruise control on/off switch, use ET to check customer specified parameters. Check the following parameters:

- "Low Cruise Control Set Speed Limit"

- “High Cruise Control Set Speed Limit”
- “Idle Vehicle Speed Limit”
- “Idle rpm Limit”

Note: If the vehicle speed exceeds the “High Cruise Control Set Speed Limit” and the driver attempts to set a cruise control speed, the cruise set speed will be the “High Cruise Control Set Speed Limit”. If the vehicle speed is below the “Low Cruise Control Set Speed Limit”, the cruise control can not be set or resumed. If the engine rpm is above the idle rpm limit and the driver attempts to set an idle engine rpm the idle engine rpm will be the idle rpm limit. If the driver attempts to set an idle engine rpm and the vehicle speed exceeds the idle vehicle speed limit, the idle will not activate. Refer to Troubleshooting, “Cruise Control Switch Circuit - Test”.

On/Off switch for Cruise Control and Idle Control

When the PTO is set by using a dedicated PTO on/off switch, use ET to check Customer Specified Parameters. Check the following parameters:

- “PTO Vehicle Speed Limit”
- “PTO Top Engine Limit”

If the vehicle speed exceeds the programmed “PTO VSL”, the ECM will not maintain the set speed. Typically, the operation of the PTO requires an interlock switch such as a parking brake switch. Ensure that all interlocks are set to allow PTO operation. Refer to Troubleshooting, “PTO Switch Circuit - Test” for additional information.

ET Status Screen

1. Connect ET to the cab data link connector. Check the status screen for the last item that caused the kickout for the cruise control, the idle control or the PTO control.

Note: ET will only provide access to the last cause of the kickout. If the ECM is powered down and the ECM is powered up, the ET display will be blank. The ECM is powered down when the ignition key switch is turned to the OFF position. It may be necessary to take the vehicle for a test drive in order to repeat the problem. Check the ET before the ECM is turned off by the keyswitch.

If ET indicates “Switch Turned Off”, go to Step 2.

If ET indicates “Brake”, “Clutch” or “Neutral” go to Step 3.

If ET indicates “Bad Vehicle Speed”, “Vehicle Speed < Limit” or “Vehicle Speed >= Limit” go to Step 4.

2. If ET indicates “Switch Turned Off”, the ECM has detected an open circuit in the on/off switch circuit. This pertains to the cruise control, the idle control or the PTO. Perform the following tests in order:
 - a. Ensure that the operator has not actually turned off the cruise control on/off switch or the PTO on/off switch.
 - b. Check the ET status screen while the switch is being used. If the problem is not apparent check the switch and the wiring.
 - c. If the problem is related to the cruise control or idle control refer to Troubleshooting, “Cruise Control Switch Circuit - Test”, Troubleshooting, “Service Brake Pedal Position (Switch 1) Circuit - Test”, and Troubleshooting, “Clutch Pedal Position Switch Circuit - Test”.
 - d. If the problem is related to the PTO refer to Troubleshooting, “PTO Switch Circuit - Test”.
3. If ET indicates “Brake”, “Clutch” or “Neutral”, the ECM has detected an open circuit in the switch circuit for the service brake, the switch circuit for the clutch or the transmission neutral switch circuit. Perform the following tests in order:
 - a. Ensure that the operator has not actually depressed the service brake pedal or the clutch pedal. Also ensure that the operator has not actually shifted the transmission to neutral.
 - b. Check the ET status screen while the service brake or the clutch is being used. If the problem is not apparent check the switches. Check the service brake switch for the air system. Ensure that the treadle valve is operating freely. A treadle valve that is not operating freely can cause pressure spikes. Check the clutch switch adjustment and the return spring.
 - c. If the problem is related to the cruise control or idle control refer to Troubleshooting, “Cruise Control Switch Circuit - Test”, Troubleshooting, “Service Brake Pedal Position (Switch 1) Circuit - Test”, and Troubleshooting, “Clutch Pedal Position Switch Circuit - Test”.
 - d. If the problem is related to the PTO refer to Troubleshooting, “PTO Switch Circuit - Test”.

4. If ET indicates “Bad Vehicle Speed”, the vehicle speed signal is erratic or intermittent. This relates to cruise control only.

If ET indicates “Vehicle Speed < Limit”, the vehicle speed signal was lost at least briefly. This pertains to cruise control only.

If ET indicates “Vehicle Speed >= Limit”, the vehicle speed signal exceeded the programmed Idle/PTO vehicle speed limit or the vehicle speed limit is erratic or intermittent. This pertains to idle control and PTO control only.

If ET indicates a “Set SW Timeout”, then either the set switch was depressed by the operator longer than 15 seconds, or the circuit has a short. The cruise control switch must be turned off and then turned on before the cruise control will work.

If ET indicates a “Res SW Timeout”, then either the set switch was depressed by the operator longer than 15 seconds, or the circuit has a short. The cruise control switch must be turned off and then turned on before the cruise control will work.

Perform the following diagnostic procedure in order:

- a. Inspect the vehicle speed sensor for debris on the sensor. Inspect the vehicle speed circuit.
- b. Check the vehicle speed that is displayed on the ET status screen while the vehicle is parked. Adjust the engine rpm up and down. Also check the vehicle speed while the vehicle is being driven in order to determine that the vehicle speed that is indicated by ET does not vary significantly from the vehicle speed that is indicated by the speedometer. If the problem is not apparent, refer to Troubleshooting, “Vehicle Speed and Speedometer Circuit - Test”.
- c. Inspect both ECM connectors for moisture. Refer to Troubleshooting, “Electrical Connectors - Inspect”.

Note: Full Feature systems require the transmission style parameter to match the switches that are installed in the vehicle. The Basic system requires the status of the clutch switch and the neutral switch to be reviewed.

i01642805

Driver Questionnaire

SMCS Code: 1000; 7569

Table 142

Ask the driver to answer the following questions before attempting to repair an intermittent problem, or a problem with symptoms but no diagnostic codes. Use this and the response guideline to these questions on the next page.		
Questions	Yes	Comments
1. Ask the driver if the Check Engine Lamp turned on during the problem or if the Check Engine Lamp turned on after the problem. The Check Engine Lamp stays on for the following time period:		
2. Ask the driver for the number of occurrences for this problem. Ask the driver to duplicate the problem if the problem can be duplicated in less than one hour.		
3. Ask the driver if other shops have worked on the same problem. If the answer is yes, ask the names of the shops. Also ask for the time period for the work that was performed.		
4. Ask the driver if the engine completely shut down. Ask the driver if the restart required the use of the ignition key switch. Ask the driver for the waiting period before the driver could restart the engine after the shutdown.		
5. Ask the driver if the engine had a hesitation, a speed burp or a misfire without a complete shutdown.		
6. Ask the driver if the radio, dash gauges or lights momentarily turn off during an occurrence of the problem. Ask the driver if there are any other observations about the truck's components.		
7. Ask the driver if the problem occurs only at specific engine loads. Ask the driver for additional details.		
8. Ask the driver if the problem occurs at a specific engine operating temperature. If the problem occurs at a specific engine operating temperature, record the engine temperature.		
9. Ask the driver if the problem occurs only at specific outside temperatures or temperature ranges. If the problem occurs only at specific outside temperatures or temperature ranges, record the outside temperature or temperature range.		
10. Ask the driver if the problem occurs during any other specific conditions.		
11. Ask the driver if the problem occurs at a specific vehicle speed. If the problem occurs at a specific vehicle speed, record the vehicle speed.		
12. Ask the driver if the vehicle kicked out of cruise control mode, idle mode or PTO mode.		
13. Ask the driver if the problem occurs during the use of the accelerator. During this time, the engine is not in cruise control mode or PTO mode.		
14. Ask the driver if the problem occurs at a specific engine rpm. If the problem occurs at a specific engine rpm record the engine rpm.		

i01641542

Driver Questionnaire Response

SMCS Code: 1000; 7569

Table 143

<p>1. If the Check Engine Lamp turned on there will be a logged diagnostic code. Refer to Troubleshooting, "Possible Performance Effect of Active Diagnostic Codes" in order to determine if the driver's indicated symptoms agree with the symptoms that are associated with the diagnostic code. If the driver's symptoms do not match the symptoms of the diagnostic code, troubleshooting the diagnostic code will not correct the problem. Review the snapshots that are associated with each diagnostic code in order to determine the operating conditions of the engine during the occurrence of the problem. Try to duplicate these conditions. If there are not any logged diagnostic codes, check the ECM battery connections. Refer to Troubleshooting, "Ignition Key Switch Circuit and Battery Supply Circuit - Test".</p>
<p>2. If the problem is easily repeatable, take the vehicle for a test drive while ET is connected to the cab data link connector. Note the conditions when the problem occurs. The operator should be prepared to take snapshot data by using ET or the Cruise Control Set/Resume switches. Ensure that you operate the vehicle after correcting the problem. During vehicle operation, duplicate the operating conditions before releasing the vehicle in order to verify that the problem has been corrected.</p>
<p>3. If the vehicle has been to other shops for the same problem, call the other shops in order to determine the type of work that has been done. Avoid replacing the same components again, unless you are absolutely sure that the components are the problem. If a component has recently been changed, it is unlikely that the component will fail again.</p>
<p>4. Troubleshoot the reason that the engine will not start. Repair the reason that the engine does not start. When you repair the reason that the engine did not start you should repair the reason that the engine shut down. If the engine shut down completely, check the ECM battery connections, the ground connections, the fuel system, the fuel, the crankshaft position sensor and the camshaft position sensor. If the engine will not restart, refer to Troubleshooting, "Engine Cranks but Will Not Start".</p>
<p>5. If the problem is easily repeatable, refer to Troubleshooting, "Engine Misfires, Runs Rough or Is Unstable". If the problem is not easily repeatable, refer to Troubleshooting, "Intermittent Low Power or Power Cutout".</p>
<p>6. If other devices on the vehicle are affected, something is wrong with the vehicle wiring. Refer to Troubleshooting, "Ignition Key Switch Circuit and Battery Supply Circuit Test" for information on inspecting the ECM battery connections.</p>
<p>7. Operate the engine under similar load conditions. Check the low pressure fuel lines for restrictions. Also check the fuel/water separator and the fuel tanks for foreign objects that are blocking the fuel supply.</p>
<p>8. Operate the engine at this temperature. Attempt to duplicate the problem.</p>
<p>9. When possible, troubleshoot the problem in this temperature range.</p>
<p>10. If the problem seems to occur during the rain or a washing, thoroughly inspect the connectors for moisture. Refer to Troubleshooting, "Electrical Connectors - Inspect".</p>
<p>11. If the problem occurs at a specific vehicle speed, check the parameters that affect vehicle speed in order to verify that the parameters are programmed close to the vehicle speed of the occurrence of the problem. Check the following parameters: "Vehicle Speed Limit" "VSL Protection" "Low Cruise Control Speed Set Limit" "High Cruise Control Speed Set Limit" "Idle Vehicle Speed Limit" "PTO Vehicle Speed Limit" "Engine/Gear Speed Limit" Set each parameter to the maximum value one at a time and verify that the problem is corrected.</p>
<p>12. If the vehicle kicks out of cruise control mode, idle mode or PTO mode and it can be duplicated, check the ET status screen. Check the status of the Cruise Kickout, the Idle Kickout or the PTO Kickout. If the problem can not be duplicated, inspect the vehicle speed circuit, the service brake circuit and the clutch switch circuit and switch adjustment, the circuit for the neutral switch and the circuits for the cruise/idle/pto switches, as required.</p>
<p>13. Check for logged diagnostic codes that are associated with the accelerator pedal position sensor. Refer to Troubleshooting, "Accelerator Pedal (Throttle) Position Sensor Circuit - Test".</p>
<p>14. If the problem occurs at a specific engine rpm, check the "VSL Protection", the "Idle rpm Limit", the "Top Engine Limit", the "PTO Top Engine Limit" and the Progressive Shift Parameters. These parameters are programmable. Set each parameter to the maximum value one at a time and verify that the problem is corrected.</p>

i01641569

ECM Will Not Accept Factory Passwords

SMCS Code: 7569

Probable Causes

The probable root causes are listed in order below:

- Incorrect password
- Incorrect serial number
- Reason code

Recommended Actions

Perform the following diagnostic procedures in order:

Incorrect password

Verify that the Caterpillar Electronic Technician (ET) is on the factory password screen. Also, verify that ET expects Factory Passwords rather than Customer Passwords.

Incorrect Serial Number

1. Verify that the engine serial number that is used to calculate the password is from the ET screen rather than the engine information plate.

For example, the engine serial number that is programmed in a new ECM is OXX00000. If ET indicates that the engine serial number is OXX00000, this engine serial number must be used to obtain Factory Passwords. Do not use the information on the engine information plate.

2. Verify that all of the information on the ET screen is the information that was supplied to Caterpillar in order to obtain the password. Refer to Illustration 18.

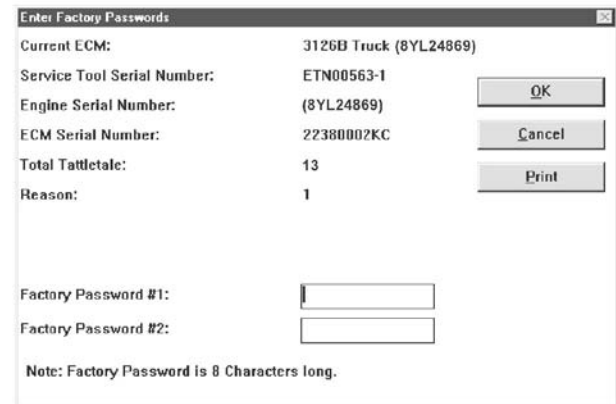

Illustration 18

g00714012

3. Verify that the information was obtained from the ECM that is being programmed. Do not accept the information from the old ECM in order to program Factory Passwords on a replacement ECM. Do not copy the information from the old ECM in order to program Factory Passwords on a replacement ECM.
 4. Verify that all characters in the ECM and/or the ET serial number have been supplied.
 5. Verify that the correct passwords were entered. The passwords are case sensitive. Ensure that the passwords are entered in the correct case. Also check the characters in the password for accuracy.
 6. Turn the ignition key switch to the OFF position and retry.
- Note:** Refer to Illustration 18. Ensure that the recorded information that is used to request the password is an exact match to the information that is displayed on the ET screen.
7. If rechecking the passwords does not correct the problem, change a Customer Parameter from the current value to another value and then change the Customer Parameter back to the original value. Then revert to the screen and proceed to obtain Factory Passwords again.

Note: The "Total Tattletale" password will need to be changed.

Reason Code

1. Verify that the correct reason code from the Factory Password Screen was entered. Do not assume the reason code. This must be obtained from ET. Reason codes are assigned for specific purposes and reason codes are not interchangeable.
2. Turn the ignition key switch to the OFF position and retry.

Note: Ensure that the information that is entered is an exact match to the information that is displayed on the ET screen.

i01748834

Electronic Service Tool Will Not Communicate with ECM

SMCS Code: 7569

Probable Causes

- Configuration for the communications adapter
- Electrical connectors
- Communication adapter and/or cables
- Electrical power supply to the service tool connector
- Cat ET and related hardware
- Electrical power supply to the ECM
- Override switches
- Personality module (flash file)
- ATA Data Link

Recommended Actions

Start the engine. If the engine starts, but the ECM will not communicate with the Caterpillar Electronic Technician (Cat ET), continue with this procedure. If the engine will not start, refer to Troubleshooting, "Engine Cranks but Will Not Start". If the engine will not crank, refer to Troubleshooting, "Engine Will Not Crank".

Configuration for the Communications Adapter

1. Access "Preferences" under the "Utilities" menu on Cat ET.

2. Verify that the correct "Communications Interface Device" is selected.
3. Verify that the correct "Port" is selected for use by the communication adapter.

Note: The most commonly used port is "COM 1".

4. Check for any hardware that is utilizing the same port as the communications adapter. If any devices are configured to use the same port, exit or close the software programs for that device.

Electrical Connectors

Check for correct installation of the J1/P1 and J2/P2 ECM connectors and the service tool connector. Refer to Troubleshooting, "Electrical Connectors - Inspect".

Communication Adapter and/or Cables

1. If you are using a Communication Adapter II, ensure that the firmware and driver files for the communication adapter are the most current files that are available. If the firmware and driver files do not match, the communication adapter will not communicate with Cat ET.
2. Disconnect the communication adapter and the cables from the service tool connector. Reconnect the communication adapter to the service tool connector.
3. Verify that the correct cable is being used between the communication adapter and the service tool connector. Refer to Troubleshooting, "Electronic Service Tools".

Electrical Power Supply to the Service Tool Connector

Verify that battery voltage is present between terminals A and B of the service tool connector. If the communication adapter is not receiving power, the display on the communication adapter will be blank.

Cat ET and Related Hardware

In order to eliminate Cat ET and the related hardware as the problem, connect Cat ET to a different engine. If the same problem occurs on a different engine, check Cat ET and the related hardware in order to determine the cause of the problem.

Electrical Power Supply to the ECM

Check power to the ECM. Refer to Troubleshooting, "Ignition Key Switch Circuit and Battery Supply Circuit - Test".

Note: If the ECM is not receiving battery voltage, the ECM will not communicate.

Override Switches

1. Ensure that the ignition key switch is in the ON position. Ensure that there are no override switches that are creating the problem.
2. Ensure that there are no aftermarket devices that are preventing battery voltage from reaching the ECM.
3. Start the engine and then connect Cat ET. Some type of override switch is interrupting the power to the ECM under the following condition: If communication occurs with the engine running but no communication occurs with the key switch in the ON position.

Personality Module (Flash File)

Ensure that the correct personality module is properly installed in the ECM.

Note: The personality module that is provided in a new ECM is blank. The engine will not start and the engine will not communicate with Cat ET until the personality module has been flashed. Refer to Troubleshooting, "Flash Programming".

ATA Data Link

Troubleshoot the ATA Data Link for possible problems. Refer to Troubleshooting, "ATA (SAE J1587 / J1708) Data Link Circuit - Test".

i01623108

Elevated Idle

SMCS Code: 1000; 7569

Probable Causes

This condition does not indicate an electronic system problem. The low idle speed may be elevated due to one of the following features:

- Low Battery Elevated Idle
- Cold Mode Elevated Idle

Note: The "Elevated Idle" status flag will be activated if one of the above features is active.

Conditions

Low Battery Elevated Idle

The engine idle speed will be elevated to the value that is programmed into the "Battery Monitor Low Idle Engine Speed" parameter when all of the following conditions occur:

- System battery voltage is less than the value that is programmed into the "Battery Monitor & Engine Control Voltage" parameter for 30 seconds.
- The vehicle is stopped.
- The transmission is not in gear.
- The brake pedal is not depressed.
- The clutch pedal is not depressed.

Cold Mode Elevated Idle

The engine idle speed will be elevated to the value that is programmed into the "Warm Up Mode Idle Speed" parameter when all of the following conditions occur:

- Cold mode is active.
- The transmission is not in gear.
- The brake pedal is not depressed.
- The clutch pedal is not depressed.

i01857351

Engine Cranks but Will Not Start

SMCS Code: 7569

Probable Causes

The probable root causes are listed in order below:

- Ignition key switch
- Engine oil pressure
- ECM Communications
- Engine protection devices

- ECM power supply
- Personality Module
- ECM
- Hydraulic Electronic Unit Injectors
- Engine speed/timing signal
- Injection actuation pressure control system
- Engine software
- Theft deterrent
- Fuel supply
- Combustion problem

Recommended Actions

Perform the following diagnostic procedures in order:

Ignition Key Switch

1. Connect an electronic service tool to the cab data link connector.
2. Access the status of the ignition key switch.
3. Slowly cycle the ignition key switch on and off while the status of the ignition key switch is being monitored. The status should indicate the state of the switch.

If the ECM will not communicate and the ignition key switch is in the ON position, refer to the next step.

Note: If the Idle Shutdown is used or the PTO Shutdown Time is used, the status of the ignition key switch may indicate that the switch is ON even though the ignition key switch is turned to the OFF position.

Engine Oil Pressure

1. Check the engine oil level. Engine oil is used to activate the high pressure hydraulic pump.
2. Ensure that the engine oil meets the recommendations of the engine manufacturer. Refer to Operation and Maintenance Manual for further details.
3. Check for air in the high pressure oil system.

Note: Crank the engine for 30 seconds. Allow time for the starter motor to cool. Crank the engine up to five times in order to purge the air from the high pressure oil system.

Check Communications

1. Connect the electronic service tool to the cab data link connector.
2. Check the communications between the ECM and the electronic service tool.
3. Ensure that the ignition key switch is in the ON position. Attempt to access one of the electronic service tool status screens.

If the electronic service tool indicates that the ECM will not communicate go to the next step. If the ECM communicates go to "Engine Software".

Note: A new ECM has a Personality Module that is not programmed. A Personality Module that is not programmed will cause this symptom. Accessing the ECM status in the electronic service tool WinFlash Program without programming the Personality Module will cause the engine not to start or accessing the ECM status in the electronic service tool WinFlash Program without programming the Personality Module will cause the engine not to communicate. Cycling the ignition key switch from the OFF to the ON position will correct this problem.

Engine Protection Devices

1. Check aftermarket engine protection devices. These devices usually interrupt power to the ECM and the ECM will not communicate with the electronic service tool.
2. Check for the correct installation of the aftermarket engine protection device.
3. Check for the correct operation of the aftermarket engine protection device.

Note: It may be necessary to disable the aftermarket engine protection device before you continue.

4. Verify the voltage supply at the ECM.

ECM Power Supply

1. Verify that the ECM is receiving battery voltage.
2. Check the electrical power supply to the ECM.
3. Check the power connection of the ECM and the ground connection of the ECM.

4. Verify that the ECM is receiving battery voltage when the ignition key switch is turned on. Refer to Troubleshooting, "Ignition Key Switch Circuit and Battery Supply Circuit - Test".
5. Connect a bypass circuit for the ECM. Refer to Illustration 19.

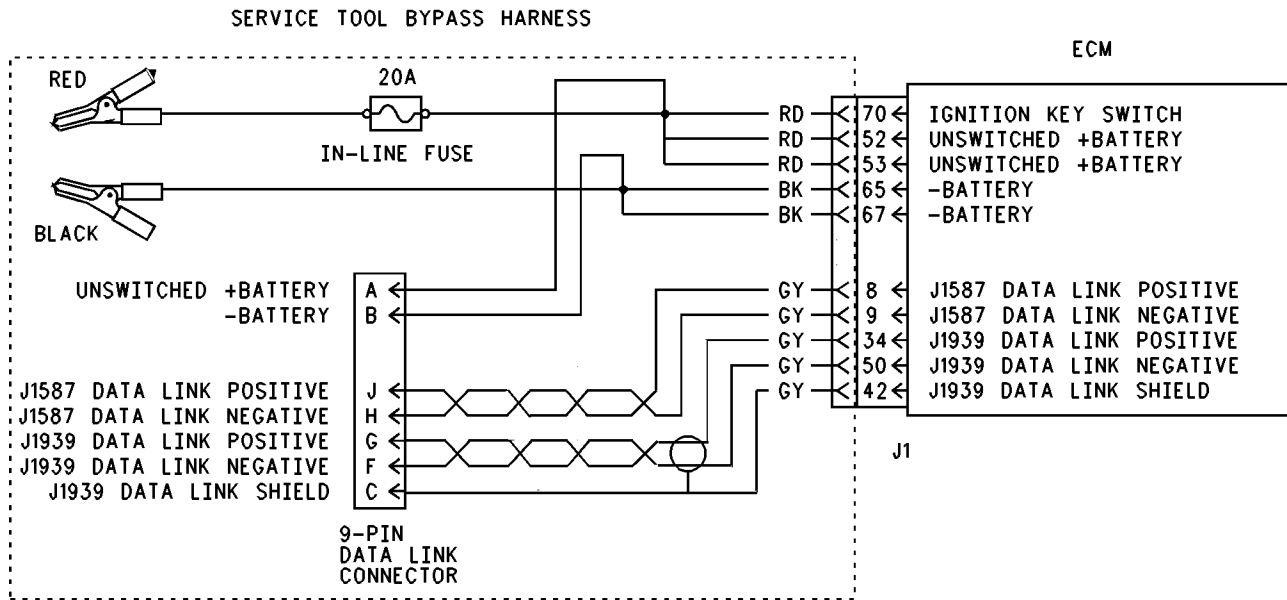

Illustration 19

g00741090

Personality Module

A new ECM has a Personality Module that is not programmed. The engine will not start until the Personality Module has been flashed. Also, the engine will not communicate until the Personality Module has been flashed.

ECM

Before replacing the ECM, try to flash program the existing ECM. Refer to Troubleshooting, "Flash Programming".

If the ECM is suspected of being the problem, temporarily connect a test ECM. This will show whether the problem has been resolved or the problem has not been resolved.

Hydraulic Electronic Unit Injectors

1. Check the electrical connections to the hydraulic electronic unit injectors.

2. Ensure that the hydraulic electronic unit injector connector (J300/P300) is fully connected and ensure that the hydraulic electronic unit injector connector (J300/P300) is free of corrosion.
3. Check for logged diagnostic codes that are related to the cylinder. Go to Troubleshooting, "Injector Solenoid Circuit - Test" if diagnostic codes that are related to the cylinder are present.

Engine Speed/Timing Signal

1. Check the engine speed/timing signal.
2. Observe the engine rpm with the electronic service tool while the engine is being cranked.

This may require the electronic service tool to be powered directly by the vehicle batteries or this may require the electronic service tool to be powered directly by a separate power source (12 VDC). Refer to Illustration 19.

There is a problem in the circuit of the speed/timing sensor if the electronic service tool display reads 0 rpm during cranking. Refer to Troubleshooting, "Engine Speed/Timing Sensor Circuit - Test".

If an engine rpm is present, check the sensor installation. If the sensor is not properly installed, the sensor may read RPM but the sensor may not be able to sense the tooth pattern. The ability to sense the tooth pattern is necessary to determine the cylinder position. Engine rpm is present when the engine rpm is 50 rpm or more.

Injection Actuation Pressure System

1. Crank the engine and monitor the injection actuation pressure and the Injection Actuation Control Valve output. The high pressure oil system is operating properly if the pressure output is a minimum of 6 MPa (870 psi).
2. Connect the electronic service tool and check for event code 164-11 Injection Actuation Pressure system fault. If an 164-11 event code has been logged recently, refer to Troubleshooting, "Injection Actuation Pressure -Test".
3. If higher than actual pressure is being indicated, then disconnect the injection actuation pressure sensor and try to start the engine. If the engine starts, refer to Troubleshooting, "Injection Actuation Pressure Sensor -Test".

Engine Software

Connect the electronic service tool and check for the correct engine software. Ensure that there is not an active 252-11 diagnostic code (Incorrect Engine Software 59) .

If the diagnostic code is present, refer to Troubleshooting, "ECM Memory - Test".

Theft Deterrent

Ensure that the theft deterrent (if equipped) is not active. Turn the ignition switch to the ON position. Observe the display screen on the CAT ID.

If the display screen on the CAT ID indicates that the theft deterrent is enabled, the Theft Deterrent Passwords must be entered before the engine will start.

Fuel Supply

1. Check the fuel supply.

2. Monitor the exhaust for smoke while the engine is being cranked.

If no smoke is present, there may be a problem with the fuel quality or there may be a problem with the fuel supply.

3. Check the fuel quality. Refer to Truck Performance and Driveability Diagnostic Guide, LEBT3477.
4. Check the fuel pressure. Refer to Testing and Adjusting, "Fuel System Pressure - Test".
5. Ensure that the fuel system has been primed. Refer to Testing and Adjusting, "Fuel System - Prime".
6. Check for fuel supply lines that are restricted.
7. Check the fuel filters.
8. If the temperature is below 0 °C (32 °F), check for solidified fuel (wax).

Combustion Problem

Check for combustion problems.

Examples of combustion problems are shown in the following list:

- Outside temperatures are too cold.
- Mechanical problem

i01434232

Engine Has Early Wear

SMCS Code: 7569

Probable Causes

- Dirt in the engine oil
- Air inlet leaks
- Fuel leakage into engine oil
- Incorrect engine oil
- Incorrect maintenance interval for the application

Recommended Repairs

Dirt in the Engine Oil

Remove dirty engine oil. Install new filter elements. Put clean oil in the engine. Check the oil filter bypass valve for a weak spring or a broken spring. Look for the source of the contamination.

Air Inlet Leaks

Inspect the air filter for leaks. Inspect all gaskets and connections. Make repairs if leaks are found.

Fuel Leakage into the Engine Oil

Fuel leakage into the engine oil will cause high fuel consumption and low engine oil pressure. This condition may also increase the oil level in the crankcase. Make repairs if leaks are found. Install new parts, as required.

Incorrect Engine Oil

Check oil recommendations for the proper oil specifications for the engine operating conditions.

Incorrect Maintenance Interval

Review the oil change intervals in relation to the nature and severity of the engine application. Review the records for the engine in order to verify that the recommended intervals are being followed.

i01641917

Engine Misfires, Runs Rough or Is Unstable

SMCS Code: 1000; 7569

Probable Causes

The probable root causes are listed in order below:

Note: If the problem is intermittent and the problem can not be duplicated, refer to Troubleshooting, "Intermittent Low Power or Power Cutout".

- Individual cylinder malfunction
- Fuel supply
- Low injection actuation pressure
- Accelerator pedal position sensor
- Power train data link
- Camshaft position sensor
- Valve lash

Recommended Repairs

Perform the following diagnostic procedures in order:

Note: If the problem only occurs under certain conditions, test the engine under those conditions. Examples of certain conditions are high rpm, full load and engine operating temperature. Troubleshooting the symptoms under other conditions can give misleading results.

Individual Cylinder Malfunction

1. Check for an individual cylinder malfunction.
2. Ensure that the hydraulic electronic unit injector connector (J300/P300) is fully connected and ensure that the hydraulic electronic unit injector connector (J300/P300) is free of corrosion.
3. Ensure that the ECM engine harness connector (J2/P2) is fully connected and ensure that the engine harness connector (J2/P2) is free of corrosion.
4. Connect Caterpillar Electronic Technician (ET) to the cab data link connector. Use the Cylinder Cutout Test. Access the Cylinder Cutout Test by selecting the "Diagnostic Menu" and the "Diagnostics Test Menu". Run the Cylinder Cutout Test in order to disable each cylinder. Disabling each cylinder allows the technician to isolate the misfiring cylinders.

If the misfiring cylinder can be isolated to a specific cylinder, refer to Troubleshooting, "Injector Solenoid Circuit - Test".

Fuel Supply

1. Monitor the exhaust for smoke while the engine is being cranked.

If no smoke is present, there may be a problem with the fuel quality or there may be a problem with the fuel supply.
2. Check the fuel quality. Refer to the Truck Performance and Driveability Diagnostic Guide, LEBT3477.
3. Check the fuel pressure. Refer to Testing and Adjusting, "Fuel System Pressure - Test".
4. Ensure that the fuel system has been primed. Refer to Testing and Adjusting, "Fuel System - Prime".
5. Check for fuel supply lines that are restricted.
6. Check the fuel filters.
7. If the temperature is below 0 °C (32 °F), check for solidified fuel (wax).

8. Check for air in the fuel system. Refer to Testing and Adjusting, "Air in Fuel - Test".

Low Injection Actuation Pressure

1. Check the engine oil level. Engine oil is used to activate the high pressure hydraulic pump.
2. Ensure that the engine oil meets the recommendations of the engine manufacturer. Refer to Operation and Maintenance Manual for further details.
3. Crank the engine and monitor the injection actuation pressure and the output of the injection actuation pressure control valve. The high pressure oil system is operating properly if the pressure output is a minimum of 6 MPa (870 psi).
4. Connect ET and check for event code 164-11 Injection Actuation Pressure system fault. If an 164-11 event code has been logged recently, refer to Troubleshooting, "Injection Actuation Pressure System-Test".

Accelerator Pedal Position Sensor

1. If the engine is in the cruise control mode and the problem does not occur, check the accelerator pedal position sensor.
2. Use the Cruise/Idle On/Off Switch to put the engine in Idle mode.
3. Vary the engine rpm with the set/resume switches.

If both of the following conditions are met, connect ET and monitor the status of the accelerator pedal position sensor.

- The engine is stable by using idle mode to control the engine rpm.
- The engine is unstable by using the accelerator pedal position sensor.

If the status of the accelerator pedal position sensor is unstable, refer to Troubleshooting, "Accelerator Pedal (Throttle) Position Sensor Circuit - Test".

Power Train Data Link

1. Check the "Power train Data Link". Ensure that the SAE J1939 data link is not limiting the power.
2. Connect ET to the cab data link connector.
3. Monitor the "Power Train Data Link" status screen while the vehicle is experiencing problems.

If the "Power Train Data Link" status screen indicates that the data link is limiting the power or the rpm, verify that this is not normal operation. If this is not normal operation, refer to the vehicle OEM for repairs.

Camshaft Position Sensor

If the signal for the Camshaft Position Sensor is lost during engine start-up, additional time may be required to start the engine. The engine may also misfire during this time until the ECM determines the proper firing order. Refer to Troubleshooting, "Engine Speed/Timing Circuit - Test".

Valve Lash

Refer to Systems Operation, Testing and Adjusting for the correct procedure.

i01668916

Engine Vibration

SMCS Code: 7569

Refer to Testing and Adjusting for information on determining the cause of this condition.

Probable Causes

- Vibration damper
- Engine supports
- Driven equipment
- Engine misfiring or running rough

Recommended Actions

Vibration Damper

Check the vibration damper for damage. Install a new vibration damper, if necessary. Inspect the mounting bolts for damage and/or wear. Replace any damaged bolts. Refer to Disassembly and Assembly, "Vibration Damper and Pulley - Remove and Install".

Engine Supports

Inspect the mounts and brackets while you run the engine through the speed range. Look for mounts and brackets that are loose and/or broken. Tighten all of the mounting bolts. Install new components, if necessary.

Driven Equipment

Check the alignment and balance of driven equipment.

Engine Misfiring or Running Rough

Refer to Troubleshooting, "Engine Misfires, Runs Rough, or Is Unstable".

i01351154

Engine Will Not Crank

SMCS Code: 7569

Probable Causes

Note: This is NOT an electronic system problem. Refer to Testing and Adjusting for additional information.

The probable root causes are listed in order below:

- Batteries
- Starting circuit
- Starting motor solenoid
- Starting motor
- Flywheel ring gear
- Transmission
- PTO
- Engine accessory
- Hydraulic cylinder lock
- Internal engine problem
- Ring gear

Recommended Actions

Perform the following diagnostic procedures in order:

1. Inspect the batteries.
 - a. Charge the batteries. Refer to Special Instruction, SEHS7633, "Battery Test Procedure".

- b. Load test the batteries. Refer to Special Instruction, SEHS9249, "Use of 4C-4911 Battery Load Tester for 6, 8 and 12 Volt Lead Acid Batteries".

2. Check the vehicle wiring to the starting motor solenoid. Refer to the OEM vehicle manual.
3. Check the engine start switch and the relay for switch power.
4. Inspect the starting motor cables for damage or loose connections.
5. If the starting motor cables are corroded, remove the starting motor cables and clean the starting motor cables.
6. Test starting motor operation.
7. Inspect flywheel ring gear for damage.
8. Ensure free movement of the driveline.
9. Remove engine accessories that may lock up the engine and inspect engine accessories that may lock up the engine.

The following list illustrates examples of engine accessories that may lock up the engine:

- Air compressor
- Power steering pump
- Engine oil pump

10. Check for fluid in the cylinders (hydraulic cylinder lock) by removing the individual hydraulic electronic unit injectors.

Note: Drain the fuel from the cylinder head. Fuel will flow from the cylinder head into the cylinders when the hydraulic electronic unit injector is removed.

11. Disassemble the engine. Inspect the internal components for the following conditions:
 - Seizure
 - Broken components
 - Bent components

Refer to Disassembly and Assembly.

12. Inspect the flywheel ring gear for damage. Refer to Disassembly and Assembly for more information.

i01641977

Excessive Black Smoke

SMCS Code: 1088-035; 7569

Probable Causes

The probable root causes are listed in order below:

- Air inlet system or exhaust system
- Valve lash
- Hydraulic electronic unit injector
- Electronic system
- ECM or Personality Module

Recommended Actions

Perform the following diagnostic procedures in order:

Air Inlet System or Exhaust System

Check the air inlet system for restrictions or leakage. Check the exhaust system for restrictions or leakage. Refer to Testing and Adjusting, "Air Inlet and Exhaust System - Inspect".

Valve Lash

Check the valve lash. Refer to Testing and Adjusting, "Engine Valve Lash - Inspect/Adjust".

Hydraulic Electronic Unit Injector

1. Ensure that the hydraulic electronic unit injector connector (J300/P300) is fully connected and ensure that the hydraulic electronic unit injector connector (J300/P300) is free of corrosion.
2. Ensure that the ECM engine harness connector (J2/P2) is fully connected and ensure that the engine harness connector (J2/P2) is free of corrosion.
3. Connect Caterpillar Electronic Technician (ET) to the cab data link connector. Use the Cylinder Cutout Test. Access the Cylinder Cutout Test by selecting the "Diagnostic Menu" and the "Diagnostics Test Menu". Run the Cylinder Cutout Test in order to disable each cylinder. Disabling each cylinder allows the technician to isolate the misfiring cylinders.

If the misfiring cylinder can be isolated to a specific cylinder, refer to Troubleshooting, "Injector Solenoid Circuit - Test".

Electronic System

1. Connect ET to the cab data link connector.
2. While the problem is occurring, check for diagnostic codes that are related to the boost pressure sensor and the atmospheric pressure sensor. If a diagnostic code is found, refer to Troubleshooting, "Engine Pressure Sensor Open or Short Circuit - Test".
3. Monitor the fuel position, the rated fuel limit and the FRC fuel limit.

While the vehicle is operating under full load, the parameters should meet the following conditions:

- The fuel position is equal to the rated fuel limit.
- The fuel position is less than the FRC fuel limit.

If the fuel position is equal to the rated fuel limit and the fuel position is less than the FRC fuel limit, the electronics are operating correctly.

4. If the fuel position is not equal to the rated fuel limit and/or the fuel position is not less than the FRC fuel limit, perform the following tests in order:
5. When the engine is OFF, turn the ignition key switch to the ON position. Check the boost pressure on the ET status screen.

When the engine is OFF, the boost pressure should be 0 kPa (0 psi).

ECM or Personality Module

Check the ECM or the Personality Module.

Refer to Troubleshooting, "ECM Memory - Test".

i01405742

Excessive Valve Lash

SMCS Code: 1105; 7569

Note: This is NOT an electronic system problem.

Refer to Testing and Adjusting for information on determining the cause of this condition.

Probable Causes

- Lubrication
- Valve lash
- Valve train components

Recommended Actions

Lubrication

1. Remove the valve mechanism covers. Refer to Disassembly and Assembly, "Valve Mechanism Cover - Remove and Install" for the correct procedure.
2. Check the lubrication in the valve compartment. Ensure that there is adequate engine oil flow in the valve compartment. The passages for the engine oil must be clean.

Valve Lash

Adjust the valve lash of the engine. Refer to Testing and Adjusting, "Air Inlet and Exhaust System" for the correct procedure.

Valve Train Components

1. Inspect the following components of the valve train:
 - Rocker arms
 - Push rods
 - Valve lifters
 - Camshaft
 - Valve stems
 - Rocker shafts
2. Check the components for the following conditions: abnormal wear, excessive wear, straightness, and cleanliness. If necessary, use new parts for replacement.

Note: If the camshaft is replaced, new valve lifters must also be used.

3. Adjust the valve lash of the engine. Refer to Testing and Adjusting, "Engine Valve Lash - Inspect/Adjust" for the correct procedure.

i01641983

Excessive White Smoke

SMCS Code: 1088-035; 7569

Probable Causes

The probable root causes are listed in order below:

- Normal operation
- Fuel supply
- Coolant temperature circuit
- Hydraulic Electronic Unit Injector
- Combustion problem
- Intake air heater
- Air inlet restriction

Recommended Actions

Perform the following diagnostic procedures in order:

Normal Operation

1. Be aware of normal operating conditions.

Cold outside temperatures can affect the production of white smoke.

Fuel Supply

1. Monitor the exhaust for smoke while the engine is being cranked.

If no smoke is present, there may be a problem with the fuel quality or there may be a problem with the fuel supply.
2. Check the fuel quality. Refer to the Truck Performance and Driveability Diagnostic Guide, LEBT3477.
3. Check the fuel pressure. Refer to Testing and Adjusting, "Fuel System Pressure - Test".
4. Ensure that the fuel system has been primed. Refer to Testing and Adjusting, "Fuel System - Prime".
5. Check for fuel supply lines that are restricted.
6. Check the fuel filters.
7. If the temperature is below 0 °C (32 °F), check for solidified fuel (wax).
8. Check for air in the fuel system. Refer to Testing and Adjusting, "Air in Fuel - Test".

Coolant Temperature Circuit

1. Connect ET to the cab data link connector.

2. Check for diagnostic codes that are related to the coolant temperature circuit.
3. Monitor the status of the coolant temperature sensor on the status screen of the Caterpillar Electronic Technician (ET). If an active open or a short circuit diagnostic code is detected, refer to Troubleshooting, "Engine Temperature Sensor Open or Short Circuit - Test".

Hydraulic Electronic Unit Injector

1. Ensure that the Hydraulic Electronic Unit Injector connector (J300/P300) is fully connected and ensure that the Hydraulic Electronic Unit Injector connector (J300/P300) is free of corrosion.
2. Ensure that the ECM engine harness connector (J2/P2) is fully connected and ensure that the engine harness connector (J2/P2) is free of corrosion.
3. Connect ET to the cab data link connector. Use the Cylinder Cutout Test. Access the Cylinder Cutout Test by selecting the "Diagnostic Menu" and the "Diagnostics Test Menu". Run the Cylinder Cutout Test in order to disable each cylinder. Disabling each cylinder allows the technician to isolate the misfiring cylinders.

If the misfiring cylinder can be isolated to a specific cylinder, refer to Troubleshooting, "Injector Solenoid Circuit - Test".

Combustion Problem

Check for combustion problems.

Examples of combustion problems are shown in the following list:

- Outside temperatures are too cold.
- Mechanical problem

Intake Air Heater

1. Inspect the wiring for the intake air heater for damage or bad connections.
2. Connect ET to the cab data link connector.
3. Check the coolant temperature sensor and the intake air temperature sensor for proper operation.
4. Check the element inside the intake air heater.
5. Check the inlet air heater relay for proper operation.

Air Inlet Restriction

Check the Air Inlet System for restrictions. Refer to Testing and Adjusting, "Air Inlet and Exhaust System - Inspect".

i01641989

Intermittent Cruise Control, Idle, or PTO Kickout

SMCS Code: 1900; 7569

Probable Causes

The probable root causes are listed in order below:

- Cruise control, idle control, and PTO control status
- A clutch pedal position switch that is incorrectly adjusted
- Malfunctioning on/off switch for cruise control and idle control
- Malfunctioning switch for service brake pedal position
- Malfunctioning transmission neutral switch
- Vehicle speed circuit problem
- Battery power or ground to the ECM

Recommended Actions

Perform the following diagnostic procedures in order:

ET Status Screen

1. Connect Caterpillar Electronic Technician (ET) to the cab data link connector. Check the status screen for the last item that caused the kickout for the cruise control, the idle control or the PTO control.

Note: ET will only provide access to the last cause of the kickout. If the ECM is powered down and the ECM is powered up, the display on ET will be blank. The ECM is powered down when the ignition key switch is turned to the OFF position. It may be necessary to take the vehicle for a test drive in order to repeat the problem. Check ET before the ECM is turned off by the keyswitch.

If ET indicates "Switch Turned Off", go to Step 2.

If ET indicates "Brake", "Clutch", or "Neutral" go to Step 3.

If ET indicates “Bad Vehicle Speed”, “Vehicle Speed < Limit”, or “Vehicle Speed >= Limit” go to Step 4.

2. If ET indicates “Switch Turned Off”, the ECM has detected an open circuit in the on/off switch circuit. This pertains to the cruise control, the idle control or the PTO. Perform the following tests in order:
 - a. Ensure that the operator has not actually turned off the cruise control on/off switch or the PTO on/off switch.
 - b. Check the ET status screen while the switch is being used. If the problem is not apparent check the switch and the wiring.
 - c. If the problem is related to the cruise control or idle control refer to Troubleshooting, “Cruise Control Circuit - Test”, Troubleshooting, “Service Brake Pedal Position (Switch 1) Circuit - Test”, and Troubleshooting, “Clutch Pedal Position Switch Circuit - Test”.
 - d. If the problem is related to the PTO refer to Troubleshooting, “PTO Switch Circuit - Test”.
3. If ET indicates “Brake”, “Clutch”, or “Neutral”, the ECM has detected an open circuit in the switch circuit for the service brake, the switch circuit for the clutch or the transmission neutral switch circuit. Perform the following tests in order:
 - a. Ensure that the operator has not actually depressed the service brake pedal or the clutch pedal. Also ensure that the operator has not actually shifted the transmission to neutral.
 - b. Check the ET status screen while the service brake or the clutch is being used. If the problem is not apparent check the switches. Check the service brake switch for the air system. Ensure that the treadle valve is operating freely. A treadle valve that is not operating freely can cause pressure spikes. Check the clutch switch adjustment and the return spring.
 - c. If the problem is related to the cruise control or idle control refer to Troubleshooting, “Cruise Control Circuit - Test”, Troubleshooting, “Service Brake Pedal Position (Switch 1) Circuit - Test”, and Troubleshooting, “Clutch Pedal Position Switch Circuit - Test”.
 - d. If the problem is related to the PTO refer to Troubleshooting, “PTO Switch Circuit - Test”.

4. If ET indicates “Bad Vehicle Speed”, the vehicle speed signal is erratic or intermittent. This relates to cruise control only.

If ET indicates “Vehicle Speed < Limit”, the vehicle speed signal was lost at least briefly. This pertains to cruise control only.

If ET indicates “Vehicle Speed >= Limit”, the vehicle speed signal exceeded the programmed idle/PTO vehicle speed limit or the vehicle speed limit is erratic or intermittent. This pertains to idle control and PTO control only.

If ET indicates a “Set SW Timeout”, then either the set switch was depressed by the operator longer than 15 seconds, or the circuit has a short. The cruise control switch must be turned off and then turned on before the cruise control will work.

If ET indicates a “Res SW Timeout”, then either the set switch was depressed by the operator longer than 15 seconds, or the circuit has a short. The cruise control switch must be turned off and then turned on before the cruise control will work.

Perform the following diagnostic procedure in order:

- a. Inspect the vehicle speed sensor for debris on the sensor. Inspect the vehicle speed circuit.
- b. Check the vehicle speed that is displayed on the ET status screen while the vehicle is parked. Adjust the engine rpm up and down. Also check the vehicle speed while the vehicle is being driven in order to determine that the vehicle speed that is indicated by ET does not vary significantly from the vehicle speed that is indicated by the speedometer. If the problem is not apparent, refer to Troubleshooting, “Vehicle Speed Circuit - Test”.
- c. Inspect both ECM connectors for moisture. Refer to Troubleshooting, “Electrical Connectors - Inspect”.

Note: Full Feature systems require the transmission style parameter to match the switches that are installed in the vehicle. The basic system requires the status of the clutch switch and the neutral switch to be reviewed.

ECM Connections

A problem with the battery power, the ground to the ECM or the vehicle wiring can cause erratic engine rpm or other more severe problems. If this is a suspected cause, refer to Troubleshooting, "Ignition Key Switch Circuit and Battery Supply Circuit Test".

i01653176

Intermittent Engine Shutdown

SMCS Code: 7569

Probable Causes

The probable root causes are listed in order below:

- Idle Shutdown and Engine Monitoring
- Battery power or ground to the ECM
- Aftermarket engine protection devices
- Fuel supply
- Engine speed/timing sensors
- Low injection actuation pressure
- ECM or Personality Module

Note: Shut down the engine before attempting to troubleshoot the problem.

Recommended Actions

Perform the following diagnostic procedures in order:

Idle Shutdown and Engine Monitoring

1. Check the parameters for "Engine Monitoring" and "Idle Shutdown".
2. Connect Caterpillar Electronic Technician (ET) to the cab data link connector. Read the following customer parameters:
 - "Engine Monitoring"
 - "Idle Shutdown Time"
3. If "Engine Monitoring" is programmed to shutdown, use ET to look for the following diagnostic codes:
 - 110-11 Very High Coolant Temperature (61)
 - 111-11 Very Low Coolant Level (62)

4. If the "Idle Shutdown Time" or the "PTO Shutdown Time" is programmed above 0, use ET to look for the following diagnostic codes:
 - 71-01 Idle Shutdown Occurrence (47)
 - 71-14 PTO Shutdown Occurrence (47)

Battery Power or Ground to the ECM

1. Ensure that the following connectors have been installed correctly:
 - ECM connectors (J1/P1 and J2/P2)
 - Injector connector (J300/P300)
 - Camshaft position sensor connector (J401/P401 and J402/P402)
2. Use ET to check for diagnostic code 168-02 (Intermittent Battery Power to the ECM). Check the power connections for the ECM and the ground connections for the ECM. If a problem is suspected, wire a bypass. Refer to Troubleshooting, "Ignition Key Switch Circuit and Battery Supply Circuit - Test".
3. If the problem occurs only after engine warm-up and the problem disappears after the engine cooldown, the circuit breakers may be tripping because of the heat. Check the circuit breakers on the vehicle in order to determine if the circuit breakers reset automatically.

Aftermarket Engine Protection Devices

1. Check aftermarket engine protection devices. These devices usually interrupt power to the ECM and the ECM will not communicate with ET.
2. Check for the correct installation of the aftermarket engine protection device.
3. Check for the correct operation of the aftermarket engine protection device.
4. Verify that the ECM is receiving battery voltage.

Fuel Supply

1. Monitor the exhaust for smoke while the engine is being cranked.

If no smoke is present, there may be a problem with the fuel quality or there may be a problem with the fuel supply.

2. Check the fuel quality. Refer to Special Publication, LEBT3477, "Truck Performance and Driveability Diagnostic Guide".
3. Check the fuel pressure. Refer to Testing and Adjusting, "Fuel System Pressure - Test".
4. Ensure that the fuel system has been primed. Refer to Testing and Adjusting, "Fuel System - Prime".
5. Check for fuel supply lines that are restricted.
6. Check the fuel filters.
7. If the temperature is below 0 °C (32 °F), check for solidified fuel (wax).

Engine Speed/Timing Sensors

Check the engine speed/timing sensors.

Refer to Troubleshooting, "Engine Speed/Timing Circuit - Test".

Low Injection Actuation Pressure

1. Check the engine oil level. Engine oil is used to activate the high pressure hydraulic pump.
2. Ensure that the engine oil meets the recommendations of the engine manufacturer. Refer to Operation and Maintenance Manual for further details.
3. Crank the engine and monitor the injection actuation pressure and the output of the injection actuation pressure control valve. The high pressure oil system is operating properly if the pressure output is a minimum of 6 MPa (870 psi).
4. Connect ET and check for event code 164-11 (Injection Actuation Pressure System). If a 164-11 event code has been logged recently, refer to Troubleshooting, "Injection Actuation Pressure System-Test".

ECM or Personality Module

Check the ECM or the Personality Module.

Refer to Troubleshooting, "ECM Memory - Test".

Intermittent Low Power or Power Cutout

SMCS Code: 7569

Probable Causes

The probable root causes are listed in order below:

- Electrical connections
- Engine Monitoring
- Battery power or ground to the ECM
- Electronic system
- Accelerator pedal position sensor
- Vehicle speed signal
- Power train data link
- Fuel supply
- Torque limit switch
- Low injection actuation pressure

Recommended Actions

Perform the following diagnostic procedures in order:

Electrical Connectors

Check the vehicle harness and the connectors. Refer to Troubleshooting, "Electrical Connectors - Inspect".

Engine Monitoring

1. Check the parameters for "Engine Monitoring".
2. Connect the electronic service tool to the cab data link connector.
3. Check for diagnostic codes that are capable of derating the engine when "Engine Monitoring" is programmed to "Derate" or "Shutdown".
 - 110-00 High Coolant Temperature Warning (61)
 - 110-11 Very High Coolant Temperature (61)
 - 111-11 Very Low Coolant Level (62)

Battery Power or Ground to the ECM

1. Ensure that the following connectors have been installed correctly:
 - ECM connectors (J1/P1 and J2/P2)
 - Injector connector (J300/P300)
 - Camshaft position sensor connector (J401/P401 and J402/P402)
2. Use the electronic service tool to check for a diagnostic code 168-02 (Intermittent Battery Power to the ECM). Check the power connections for the ECM and the ground connections for the ECM. If a problem is suspected, wire a bypass. Refer to Troubleshooting, "Ignition Key Switch Circuit and Battery Supply Circuit - Test"(51).

Electronic System

1. Connect the electronic service tool to the cab data link connector.
2. Monitor the fuel position, the rated fuel limit and the FRC fuel limit.

While the vehicle is operating under full load, the parameters should meet the following conditions:

- The fuel position is equal to the rated fuel limit.
- The fuel position is less than the FRC fuel limit.

If the fuel position is equal to the rated fuel limit and the fuel position is less than the FRC fuel limit, the electronics are operating correctly. Proceed to "Vehicle Speed Signal".

3. If the fuel position is not equal to the rated fuel limit and/or the fuel position is not less than the FRC fuel limit, perform the following tests in order:
4. When the engine is off, turn the ignition key switch to the ON position. Check the boost pressure on the electronic service tool status screen.

When the engine is off, the boost pressure should be 0 kPa (0 psi).

Accelerator Pedal Position Sensor

Monitor the status of the accelerator pedal position sensor. Operate the engine at high idle with the vehicle in neutral.

If the engine can not reach the programmed Top Engine Limit, check the duty cycle of the accelerator pedal position sensor in order to ensure that the duty cycle is within calibration (75 to 90 Percent at high idle).

If the accelerator pedal position is unstable, check the duty cycle of the accelerator pedal position sensor. Check the duty cycle of the accelerator pedal position sensor by slowly operating the accelerator pedal in order to verify that the accelerator pedal position sensor is within calibration. The accelerator pedal position sensor is within calibration when both of the following conditions are met:

- 10 to 22 percent at low idle
- 75 to 90 percent at high idle

Also, ensure that the duty cycle changes as the pedal position changes.

If a problem with the accelerator pedal position sensor is suspected, refer to Troubleshooting, "Accelerator Pedal (Throttle) Position Sensor Circuit - Test".

Vehicle Speed Signal

Monitor the vehicle speed signal. Ensure the accuracy of the vehicle speed signal by comparing the vehicle speed signal to the actual vehicle speed.

If the vehicle speed is greater than the "VSL", the Power is limited. If a problem is discovered, refer to Troubleshooting, "Vehicle Speed and Speedometer Circuit - Test".

Power Train Data Link

1. Check the "Powertrain Data Link". Ensure that the SAE J1939 data link is not limiting the power.
2. Connect the electronic service tool to the cab data link connector.
3. Monitor the "Powertrain Data Link" status screen while the vehicle is experiencing problems.

If the "Powertrain Data Link" status screen indicates that the data link is limiting the power or the rpm, verify that this is not normal operation. If this is not normal operation, refer to the vehicle OEM for repairs.

Fuel Supply

1. Monitor the exhaust for smoke while the engine is being cranked.

If no smoke is present, there may be a problem with the fuel quality or there may be a problem with the fuel supply.

2. Check the fuel quality. Refer to the Truck Performance and Driveability Diagnostic Guide, LEBT3477.
3. Check the fuel pressure. Refer to Testing and Adjusting, "Fuel System Pressure - Test".
4. Ensure that the fuel system has been primed. Refer to Testing and Adjusting, "Fuel System - Prime".
5. Check for fuel supply lines that are restricted.
6. Check the fuel filters.
7. If the temperature is below 0 °C (32 °F), check for solidified fuel (wax).
8. Check for air in the fuel system. Refer to Testing and Adjusting, "Air in Fuel - Test".

Torque Limit Switch

1. Connect the electronic service tool to the cab data link connector.
2. Check the setting for the Customer Parameter for the "Torque Limit".

If the "Torque Limit" is programmed below 2712 N·m (2000 lb ft), check the status screen for the torque limit switch. Ensure that the status screen indicates that the torque limit switch is off. If the status of the torque limit switch is on and a "Torque Limit" is programmed, the system is operating correctly. If the switch that is connected to this signal input is not switching on and switching off, refer to Troubleshooting, "PTO Switch Circuit - Test".

Low Injection Actuation Pressure

1. Check the engine oil level. Engine oil is used to activate the high pressure hydraulic pump.
2. Ensure that the engine oil meets the recommendations of the engine manufacturer. Refer to Operation and Maintenance Manual for further details.
3. Crank the engine and monitor the injection actuation pressure and the output of the injection actuation pressure control valve. The high pressure oil system is operating properly if the pressure output is a minimum of 6 MPa (870 psi).

4. Connect the electronic service tool to the cab data link connector and check for event code 164-11 injection actuation pressure system fault . If an 164-11 event code has been logged recently, refer to Troubleshooting, "Injection Actuation Pressure -Test".

i01857468

Low Power/Poor or No Response to Throttle

SMCS Code: 7569

Probable Causes

The probable root causes are listed in order below:

- Customer Specified Parameters (normal operation)
- Cold Mode operation
- Torque limit switch
- Electronic system
- Vehicle speed signal
- Power train data link
- Fuel supply
- Air Inlet and exhaust system
- Malfunction of an individual cylinder
- Low injection actuation pressure

Recommended Actions

Perform the following tests in order:

Customer Specified Parameters

1. Check Customer Specified Parameters.
2. Verify that the complaint is not normal operation (programmed parameter).
3. Connect the electronic service tool to the cab data link connector.
4. Check the following parameters:
 - "Rating Number"
 - "Top Engine Limit"

- “Vehicle Speed Limit”
 - “Lower Gears Engine RPM Limit”
 - “Intermediate Gears Engine RPM Limit”
 - “Gear Down Protection Engine RPM Limit”
5. Set each parameter to the parameter’s maximum value one at a time and determine whether the problem is corrected.

Cold Mode Operation

Note: This is normal operation if the problem occurs only after start-up in cold weather.

1. Connect the electronic service tool to the cab data link connector.
2. Monitor the electronic service tool in order to verify that the engine has progressed from cold mode.

An active cold mode is indicated in the upper corner of any status screen.

Torque Limit Switch

1. Connect the electronic service tool to the cab data link connector.
2. Check the setting for the Customer Parameter for the “Torque Limit”.

If the “Torque Limit” is programmed below 2712 N·m (2000 lb ft), check the status screen for the torque limit switch. Ensure that the status screen indicates that the torque limit switch is off. If the status of the torque limit switch is on and a “Torque Limit” is programmed, the system is operating correctly. If the switch that is connected to this signal input is not switching on and switching off, refer to Troubleshooting, “PTO Switch Circuit - Test”.

Electronic System

1. Connect the electronic service tool to the cab data link connector.
2. Monitor the Fuel Position, the Rated Fuel Limit and the Fuel Limit for the Fuel Ratio Control (FRC).

While the vehicle is operating under full load, the parameters should meet the following conditions:

- The fuel position is equal to the rated fuel limit.
- The fuel position is less than the FRC limit.

If the fuel position is equal to the rated fuel limit and the fuel position is less than the FRC limit, the electronics are operating correctly. Proceed to “Vehicle Speed Signal”.

3. If the fuel position is not equal to the rated fuel limit and/or the fuel position is not less than the FRC limit, perform the following tests in order:
4. When the engine is off, turn the ignition key switch to the ON position. Check the boost pressure on the electronic service tool status screen.

When the engine is off, the boost pressure should be 0 kPa (0 psi).

Accelerator Pedal Position

1. Connect the electronic service tool to the cab data link connector.
2. Monitor the status of the accelerator pedal position sensor. Operate the engine at high idle with the vehicle in neutral.

If the engine can not reach the programmed top engine limit, check the duty cycle of the accelerator pedal position sensor in order to ensure that the duty cycle of the accelerator pedal position sensor is within calibration (75 to 90 percent at high idle).

If the accelerator pedal position is unstable, check the duty cycle of the accelerator pedal position sensor. Check the duty cycle of the accelerator pedal position sensor by slowly operating the accelerator pedal in order to verify that the accelerator pedal position sensor is within calibration. The accelerator pedal position sensor is within calibration when both of the following conditions are met:

- 10 to 22 percent at low idle
- 75 to 90 percent at high idle

Also, ensure that the duty cycle changes as the pedal position changes.

If a problem with the accelerator pedal position sensor is suspected, refer to Troubleshooting, “Accelerator Pedal (Throttle) Position Sensor Circuit - Test”.

Vehicle Speed Signal

Monitor the vehicle speed signal. Ensure the accuracy of the vehicle speed signal by comparing the vehicle speed signal to the actual vehicle speed.

If the vehicle speed is greater than the “VSL”, the Power is limited. If a problem is discovered, refer to Troubleshooting, “Vehicle Speed Circuit - Test”.

Power Train Data Link

1. Check the power train data link. Ensure that the SAE J1922 data link or the SAE J1939 data link is not limiting the power.
2. Connect the electronic service tool to the cab data link connector.
3. Monitor the “Powertrain Data Link” status screen while the vehicle is experiencing problems.

If the “Powertrain Data Link” status screen indicates that the data link is limiting the power or the rpm, verify that this is not normal operation. If this is not normal operation, refer to the vehicle OEM for repairs.

Fuel Supply

1. Monitor the exhaust for smoke while the engine is being cranked.

If no smoke is present, there may be a problem with the fuel quality or there may be a problem with the fuel supply.

2. Check the fuel quality. Refer to the Truck Performance and Driveability Diagnostic Guide, LEBT3477.
3. Check the fuel pressure. Refer to Testing and Adjusting, “Fuel System Pressure - Test”.
4. Ensure that the fuel system has been primed. Refer to Testing and Adjusting, “Fuel System - Prime”.
5. Check for fuel supply lines that are restricted.
6. Check the fuel filters.
7. If the temperature is below 0 °C (32 °F), check for solidified fuel (wax).
8. Check for air in the fuel system. Refer to Testing and Adjusting, “Air in Fuel - Test”.

Air Inlet and Exhaust System

1. Check for leakage in the air-to-air aftercooler core. Refer to Testing and Adjusting, “Aftercooler - Test”.

2. Check the air inlet system for restrictions or leakage. Check the exhaust system for restrictions or leakage. Refer to Testing and Adjusting, “Air Inlet and Exhaust System - Inspect”.

Individual Cylinder Malfunction

1. Ensure that the electronic unit injector connector (J300/P300) is fully connected and ensure that the electronic unit injector connector (J300/P300) is free of corrosion.
2. Ensure that the ECM engine harness connector (J2/P2) is fully connected and ensure that the engine harness connector (J2/P2) is free of corrosion.
3. Connect the electronic service tool to the cab data link connector. Use the Cylinder Cutout Test. Access the Cylinder Cutout Test by selecting the “Diagnostic Menu” and the “Diagnostics Test Menu”. Run the Cylinder Cutout Test in order to disable each cylinder. Disabling each cylinder allows the technician to isolate the misfiring cylinders.

If the misfiring cylinder can be isolated to a specific cylinder, refer to Troubleshooting, “Injector Solenoid Circuit - Test”.

4. Perform a Performance Analysis Report (PAR).

Low Injection Actuation Pressure

1. Check the engine oil level. Engine oil is used to activate the high pressure hydraulic pump.
2. Ensure that the engine oil meets the recommendations of the engine manufacturer. Refer to the Operation and Maintenance Manual for further details.
3. Crank the engine and monitor the injection actuation pressure and the output of the injection actuation pressure control valve. The high pressure oil system is operating properly if the pressure output is a minimum of 6 MPa (870 psi).
4. Connect the electronic service tool and check for event code 164-11 injection actuation pressure system fault. If an 164-11 event code has been logged recently, refer to Troubleshooting, “Injection Actuation Pressure -Test”.

i01642129

Poor Acceleration or Response

SMCS Code: 1000; 7569

Probable Causes

The probable root causes are listed in order below:

- Customer Specified Parameters
- Electronic system
- Cold Mode operation
- Malfunction of an individual cylinder
- Power Train Data Link
- ECM or Personality Module
- Torque limit switch
- Theft Deterrent
- Injection actuation pressure
- Combustion problem

Recommended Actions

Perform the following diagnostic procedures in order:

Customer Specified Parameters

1. Check Customer Specified Parameters.
2. Verify that the complaint is not normal operation (programmed parameter).
3. Connect Caterpillar Electronic Technician (ET) to the cab data link connector.
4. Check the following parameters:
 - "Rating Number"
 - "Top Engine Limit"
 - "Vehicle Speed Limit"
 - "Lower Gears Engine RPM Limit"
 - "Intermediate Gears Engine RPM Limit"
 - "Gear Down Protection Engine RPM Limit"
5. Set each parameter to the parameter's maximum value one at a time and determine whether the problem is corrected.

Electronic System

1. Connect ET to the cab data link connector.
2. While the problem is occurring, check for diagnostic codes that are related to the boost pressure sensor and the atmospheric pressure sensor. If a diagnostic code is found, refer to Troubleshooting, "Engine Pressure Sensor Open or Short Circuit - Test".
3. Monitor the fuel position, the rated fuel limit and the fuel limit for fuel ratio control (FRC).

While the vehicle is operating under full load, the parameters should meet the following conditions:

- The fuel position is equal to the rated fuel limit.
- The fuel position is less than the FRC limit.

If the fuel position is equal to the rated fuel limit and the fuel position is less than the FRC limit, the electronics are operating correctly.

4. If the fuel position is not equal to the rated fuel limit and/or the fuel position is not less than the FRC limit, perform the following tests in order:
5. When the engine is OFF, turn the ignition key switch to the ON position. Check the boost pressure on the ET status screen. When the engine is OFF, the boost pressure should be 0 kPa (0 psi).

Cold Mode Operation

Note: This is normal operation if the problem occurs only after start-up in cold weather.

1. Connect ET to the cab data link connector.
2. Use ET to verify that the engine has progressed from cold mode. An active cold mode is indicated in the upper corner of any status screen.

Individual Cylinder Malfunction

1. Ensure that the electronic unit injector connector (J300/P300) is fully connected and ensure that the electronic unit injector connector (J300/P300) is free of corrosion.
2. Ensure that the ECM engine harness connector (J2/P2) is fully connected and ensure that the engine harness connector (J2/P2) is free of corrosion.

3. Connect ET to the cab data link connector. Use the Cylinder Cutout Test. Access the Cylinder Cutout Test by selecting the "Diagnostic Menu" and the "Diagnostics Test Menu". Run the Cylinder Cutout Test in order to disable each cylinder. Disabling each cylinder allows the technician to isolate the misfiring cylinders.

If the misfiring cylinder can be isolated to a specific cylinder, refer to Troubleshooting, "Injector Solenoid Circuit - Test".

4. Perform a Performance Analysis Report (PAR).

Power Train Data Link

1. Check the "Powertrain Data Link". Ensure that the SAE J1939 data link is not limiting the power.
2. Connect ET to the cab data link connector.
3. Monitor the "Powertrain Data Link" status screen while the vehicle is experiencing problems.

If the "Powertrain Data Link" status screen indicates that the data link is limiting the power or the rpm, verify that this is not normal operation. If this is not normal operation, refer to the vehicle OEM for repairs.

ECM or Personality Module

Check the ECM or the Personality Module.

Refer to Troubleshooting, "ECM Memory - Test".

Torque Limit Switch

1. Connect ET to the cab data link connector.
2. Check the setting for the Customer Parameter for the "Torque Limit". If the "Torque Limit" is programmed below 2712 N·m (2000 lb ft), check the status screen for the torque limit switch. Ensure that the status screen indicates that the torque limit switch is off. If the status of the torque limit switch is on and a "Torque Limit" is programmed, the system is operating correctly. If the switch that is connected to this signal input is not switching on and switching off, refer to Troubleshooting, "PTO Switch Circuit - Test".

Theft Deterrent

Ensure that the theft deterrent (if equipped) is not active. Turn the ignition switch to the ON position. Observe the display screen on the CAT ID. If the display screen on the CAT ID indicates that the theft deterrent is enabled, the Theft Deterrent Passwords must be entered before the engine will start.

Injection Actuation Pressure System

Note: Check the actual injection actuation pressure against the desired injection actuation pressure.

1. Crank the engine and monitor the Injection actuation pressure and the injection actuation pressure control valve. The high pressure oil system is operating properly if the pressure output is a minimum of 6 MPa (870 psi).
2. Connect ET and check for event code 164-11 injection actuation pressure system fault. If an 164-11 event code has been logged recently, refer to Troubleshooting, "Injection Actuation Pressure System - Test".
3. If higher than actual pressure is being indicated, then disconnect the injection actuation pressure sensor and try to start the engine. If the engine starts, refer to Troubleshooting, "Injection Actuation Pressure Sensor - Test".

Combustion Problem

Check for combustion problems.

Examples of combustion problems are shown in the following list:

- Outside temperatures are too cold.
- Mechanical problem

Troubleshooting with a Diagnostic Code

i01501859

No Diagnostic Code Detected (55)

SMCS Code: 1000; 1900

Conditions Which Generate This Code:

A Flash Code 55 indicates that the system has not detected any system faults since the last powerup.

System Response:

This code will not appear on a service tool. The check engine lamp is used to display the flash code. For more information on flash codes, refer to Troubleshooting, "Check Engine Lamp Circuit - Test".

Troubleshooting:

There are no problems that require troubleshooting.

Results:

- OK – STOP.

i01638559

0001-11 Cylinder 1 Fault (72)

SMCS Code: 1290-038

Conditions Which Generate This Code:

The ECM detects one of the following items after attempting to operate the injector:

- An open circuit exists in the wiring for the No. 1 cylinder injector solenoid.
- An internal open circuit exists in the No. 1 cylinder injector solenoid.
- A short circuit to ground on the injector solenoid for the No. 1 cylinder exists. The circuit is grounded to the engine.
- A short circuit in the injector solenoid for the No. 1 cylinder exists.
- A short circuit in the injector solenoid to battery voltage for the No. 1 cylinder exists.

If the cause of the diagnostic code is a short circuit or an open circuit in the injector common line, a fault will be active for both cylinders because of the shared common wiring for the injectors.

System Response:

Electronic System Response The ECM will illuminate the Check Engine Lamp while the fault is active. The ECM will log the diagnostic code.

Service Tool Display or Lamps Caterpillar Electronic Technician (ET) will indicate a low reading for an injector that has this fault in comparison to other injectors when the Cylinder Cutout Test is performed.

Engine Response The injector may not operate while the conditions exist. If the problem is in the common return line, neither injector will operate.

Troubleshooting:

Perform the following diagnostic procedure: "Injector Solenoid Circuit - Test"

Results:

- OK – STOP.

i01638568

0002-11 Cylinder 2 Fault (72)

SMCS Code: 1290-038

Conditions Which Generate This Code:

The ECM detects one of the following items after attempting to operate the injector:

- An open circuit exists in the wiring for the No. 2 cylinder injector solenoid.
- An internal open circuit exists in the No. 2 cylinder injector solenoid.
- A short circuit to ground on the injector solenoid for the No. 2 cylinder exists. The circuit is grounded to the engine.
- A short circuit in the injector solenoid for the No. 2 cylinder exists.
- A short circuit in the injector solenoid to battery voltage for the No. 2 cylinder exists.

If the cause of the diagnostic code is a short circuit or an open circuit in the injector common line, a fault will be active for both cylinders because of the shared common wiring for the injectors.

System Response:

Electronic System Response The ECM will illuminate the Check Engine Lamp while the fault is active. The ECM will log the diagnostic code.

Service Tool Display or Lamps Caterpillar Electronic Technician (ET) will indicate a low reading for an injector that has this fault in comparison to other injectors when the Cylinder Cutout Test is performed.

Engine Response The injector may not operate while the conditions exist. If the problem is in the common return line, neither injector will operate.

Troubleshooting:

Perform the following diagnostic procedure: "Injector Solenoid Circuit - Test"

Results:

- OK – STOP.

i01743663

0003-11 Cylinder 3 Fault (73)

SMCS Code: 1290-038

Conditions Which Generate This Code:

The ECM detects one of the following items after attempting to operate the injector:

- An open circuit exists in the wiring for the No. 3 cylinder injector solenoid.
- An internal open circuit exists in the No. 3 cylinder injector solenoid.
- A short circuit to ground on the injector solenoid for the No. 3 cylinder exists. The circuit is grounded to the engine.
- A short circuit in the injector solenoid for the No. 3 cylinder exists.
- A short circuit in the injector solenoid to battery voltage for the No. 3 cylinder exists.

If the cause of the diagnostic code is a short circuit or an open circuit in the injector common line, a fault will be active for both cylinders because of the shared common wiring for the injectors.

System Response:

Electronic System Response The ECM will illuminate the Check Engine Lamp while the fault is active. The ECM will log the diagnostic code.

Service Tool Display or Lamps Caterpillar Electronic Technician (Cat ET) will indicate a low reading for an injector that has this fault in comparison to other injectors when the Cylinder Cutout Test is performed.

Engine Response The injector may not operate while the conditions exist. If the problem is in the common return line, neither injector will operate.

Troubleshooting:

Perform the following diagnostic procedure: "Injector Solenoid Circuit - Test"

Results:

- OK – STOP.

i01638572

0004-11 Cylinder 4 Fault (73)

SMCS Code: 1290-038

Conditions Which Generate This Code:

The ECM detects one of the following items after attempting to operate the injector:

- An open circuit exists in the wiring for the No. 4 cylinder injector solenoid.
- An internal open circuit exists in the No. 4 cylinder injector solenoid.
- A short circuit to ground on the injector solenoid for the No. 4 cylinder exists. The circuit is grounded to the engine.
- A short circuit in the injector solenoid for the No. 4 cylinder exists.
- A short circuit in the injector solenoid to battery voltage for the No. 4 cylinder exists.

If the cause of the diagnostic code is a short circuit or an open circuit in the injector common line, a fault will be active for both cylinders because of the shared common wiring for the injectors.

System Response:

Electronic System Response The ECM will illuminate the Check Engine Lamp while the fault is active. The ECM will log the diagnostic code.

Service Tool Display or Lamps Caterpillar Electronic Technician (ET) will indicate a low reading for an injector that has this fault in comparison to other injectors when the Cylinder Cutout Test is performed.

Engine Response The injector may not operate while the conditions exist. If the problem is in the common return line, neither injector will operate.

Troubleshooting:

Perform the following diagnostic procedure: "Injector Solenoid Circuit - Test"

Results:

- OK – STOP.

i01638574

0005-11 Cylinder 5 Fault (74)

SMCS Code: 1290-038

Conditions Which Generate This Code:

The ECM detects one of the following items after attempting to operate the injector:

- An open circuit exists in the wiring for the No. 5 cylinder injector solenoid.
- An internal open circuit exists in the No. 5 cylinder injector solenoid.
- A short circuit to ground on the injector solenoid for the No. 5 cylinder exists. The circuit is grounded to the engine.
- A short circuit in the injector solenoid for the No. 5 cylinder exists.
- A short circuit in the injector solenoid to battery voltage for the No. 5 cylinder exists.

If the cause of the diagnostic code is a short circuit or an open circuit in the injector common line, a fault will be active for both cylinders because of the shared common wiring for the injectors.

System Response:

Electronic System Response The ECM will illuminate the Check Engine Lamp while the fault is active. The ECM will log the diagnostic code.

Service Tool Display or Lamps Caterpillar Electronic Technician (ET) will indicate a low reading for an injector that has this fault in comparison to other injectors when the Cylinder Cutout Test is performed.

Engine Response The injector may not operate while the conditions exist. If the problem is in the common return line, neither injector will operate.

Troubleshooting:

Perform the following diagnostic procedure: "Injector Solenoid Circuit - Test"

Results:

- OK – STOP.

i01638580

0006-11 Cylinder 6 Fault (74)

SMCS Code: 1290-038

Conditions Which Generate This Code:

The ECM detects one of the following items after attempting to operate the injector:

- An open circuit exists in the wiring for the No. 6 cylinder injector solenoid.
- An internal open circuit exists in the No. 6 cylinder injector solenoid.
- A short circuit to ground on the injector solenoid for the No. 6 cylinder exists. The circuit is grounded to the engine.
- A short circuit in the injector solenoid for the No. 6 cylinder exists.
- A short circuit in the injector solenoid to battery voltage for the No. 6 cylinder exists.

If the cause of the diagnostic code is a short circuit or an open circuit in the injector common line, a fault will be active for both cylinders because of the shared common wiring for the injectors.

System Response:

Electronic System Response The ECM will illuminate the Check Engine Lamp while the fault is active. The ECM will log the diagnostic code.

Service Tool Display or Lamps Caterpillar Electronic Technician (ET) will indicate a low reading for an injector that has this fault in comparison to other injectors when the Cylinder Cutout Test is performed.

Engine Response The injector may not operate while the conditions exist. If the problem is in the common return line, neither injector will operate.

Troubleshooting:

Perform the following diagnostic procedure:
“Injector Solenoid Circuit - Test”

Results:

- OK – STOP.

i01643489

0022-13 Check Timing Sensor Calibration (42)

SMCS Code: 1912-038

Conditions Which Generate This Code:

The timing has not been calibrated since the ECM was installed or the calibration is out of specification by an amount that is greater than the amount that is allowed by the ECM.

System Response:

Electronic System Response The ECM uses default timing. Timing can be out of specification by as much as 4 degrees.

Engine Response The engine may run rough or the engine may emit white smoke in the exhaust. There may not be any noticeable performance effect.

Troubleshooting:

Perform the following diagnostic procedure: “Engine Speed/Timing Sensor - Calibrate”

Results:

- OK – STOP.

i01638584

0030-08 Invalid PTO Throttle Signal (29)

SMCS Code: 1913-038

Conditions Which Generate This Code:

The “PTO Configuration” is a Customer Parameter. The “PTO Configuration” is programmed to “Remote Throttle”. The ECM is not receiving a correct signal for the PTO Accelerator.

Note: If the “PTO Configuration” is programmed to “Remote Throttle”, the ECM must receive a proper signal from the remote accelerator position sensor at all times. The remote throttle signal must be present even when the PTO ON/OFF switch is in the OFF position.

System Response:

Electronic System Response The ECM returns the engine to low idle when the problem is detected.

Service Tool Display or Lamps Caterpillar Electronic Technician (ET) will display “0%” and “DIAG” next to “Throttle Position” on the status screen while the diagnostic code is active.

Engine Response The engine will remain at low idle while the diagnostic code is active.

Troubleshooting:

The diagnostic code is probably caused by an open circuit in the signal circuit for the accelerator pedal position or an open circuit in the 12 volt sensor supply voltage circuit. An abnormal change in the signal frequency can also cause this code.

Perform the following diagnostic procedure:
“Remote PTO Accelerator Position Sensor Circuit - Test”

Results:

- OK – STOP.

i01638590

0030-13 PTO Throttle Sensor Calibration (29)

SMCS Code: 1913-524

Conditions Which Generate This Code:

The PTO Configuration is a Customer Parameter. The PTO Configuration is programmed to “Remote Throttle”. The duty cycle of the signal for the PTO Accelerator is less than 5 percent or more than 95 percent.

System Response:

Electronic System Response The ECM returns the engine to low idle when the problem is detected.

Service Tool Display or Lamps Caterpillar Electronic Technician (ET) will display “0%” and “DIAG” next to “Throttle Position” on the status screen while the diagnostic code is active.

Engine Response The engine will remain at low idle while the diagnostic code is active.

Troubleshooting:

Note: The Remote Accelerator Pedal Position Sensor can not be calibrated.

Perform the following diagnostic procedure:
"Remote PTO Accelerator Position Sensor Circuit - Test"

Results:

- OK – STOP.

i01643926

0041-03 8 Volt Supply Above Normal (21)

SMCS Code: 1408-081; 1900-038; 1901-038

Conditions Which Generate This Code:

The supply voltage for the accelerator pedal position sensor is too high.

System Response:

Engine Response An active diagnostic code may not cause any noticeable effect on engine response unless the voltage is significantly above 8 volts. The engine may be limited to low idle.

Troubleshooting:

Perform the following diagnostic procedure:
"Accelerator Pedal (Throttle) Position Sensor Circuit - Test"

Results:

- OK – STOP.

i01643931

0041-04 8 Volt Supply Below Normal (21)

SMCS Code: 1408-081; 1900-038; 1901-038

Conditions Which Generate This Code:

The supply voltage for the accelerator pedal position sensor is lower than the required voltage.

System Response:

Engine Response An active diagnostic code may not cause any noticeable effect on engine response unless the voltage is significantly below 8 volts. The engine may be limited to low idle.

Troubleshooting:

Perform the following diagnostic procedure:
"Accelerator Pedal (Throttle) Position Sensor Circuit - Test"

Results:

- OK – STOP.

i01643937

0042-11 Injection Actuation Pr Control Valve Driver (18)

SMCS Code: 1408-081; 5051-038

Conditions Which Generate This Code:

The ECM detected one of the following conditions:

- Open circuit
- Short to ground
- Short to + battery
- Short across the solenoid when the engine is running.

System Response:

Electronic System Response The ECM will cycle the control valve for the injection actuation system on and off. The ECM will cycle the control valve several times in a second when the engine is running. The fault is active.

Engine Response The engine will stop running if the signal line for the control valve for the injection actuation system is shorted to ground.

If the pressure sensor common for the control valve is shorted to ground, the following conditions may exist:

- The engine may continue to run.
- The idle may be unstable.

Troubleshooting:

Perform the following diagnostic procedure:
"Injection Actuation Pressure Control Valve Circuit - Test"

Results:

- OK – STOP.

i01643942

0064-02 Loss of Engine RPM Signal #2 (34)

SMCS Code: 1408-081; 1907-038

Conditions Which Generate This Code:

The signal for the camshaft position sensor 2 (bottom) is intermittent or lost.

System Response:

Electronic System Response The check engine lamp will not be illuminated for this code unless the code has been active for 10 hours. The code is logged.

Engine Response There should not be a noticeable change in engine response unless the signal for the camshaft position sensor 1 (top) is lost. This loss will shut down the engine.

Troubleshooting:

Perform the following diagnostic procedure: "Engine Speed/Timing Sensor Circuit - Test"

Results:

- OK – STOP.

i01643944

0064-11 No Pattern on Speed Sensor #2 (34)

SMCS Code: 1907-038

Conditions Which Generate This Code:

The signal for the camshaft position sensor 2 (bottom) is lost.

System Response:

Electronic System Response The check engine lamp will not be illuminated for this code unless the code has been active for 10 hours. The code is logged.

Engine Response There should not be a noticeable change in engine response unless the signal for the camshaft position sensor 1 (top) is lost. This loss will shut down the engine.

i01638595

0043-02 Ignition Key Switch Fault (71)

SMCS Code: 1416-038; 1553-038

Conditions Which Generate This Code:

This indicates that the battery circuit to the ignition key switch has an intermittent condition or a low battery condition while the engine is running.

Note: This code can be generated by rapidly cycling the ignition key switch. Some control modules on the vehicle require this action in order to prompt flash codes. If this occurs, clear the logged diagnostic codes in order to prevent future confusion or an incorrect diagnosis.

Note: This code can also be generated when an attempt is made in order to restart the engine immediately after a shutdown. The engine may not start if the engine speed did not reach 0 rpm prior to the restart.

System Response:

Electronic System Response The ECM may stop the fuel injection process. This response depends on the amount of time that occurs in the fault mode.

Engine Response The engine may experience burps in engine rpm, and engine shutdowns that are intermittent or complete.

Service Tool Display or Lamps Caterpillar Electronic Technician (ET) will display the state of the ignition key switch on the status screen. The Check Engine Lamp and the Warning Lamps may come on as if the ignition key switch was turned on and the engine started.

Troubleshooting:

Perform the following diagnostic procedure: "Ignition Key Switch Circuit and Battery Supply Circuit - Test"

Results:

- OK – STOP.

Troubleshooting:

Perform the following diagnostic procedure: "Engine Speed/Timing Sensor Circuit - Test"

Results:

- OK – STOP.

i01643948

0070-05 Inlet Air Heater Open Circuit (49)

SMCS Code: 1408-081; 1907-038

Conditions Which Generate This Code:

The ECM has detected an open circuit after attempting to activate the air inlet heater.

System Response:

Electronic System Response The ECM is unable to activate the air inlet heater.

Engine Response The engine may be difficult to start in the cold temperature and the exhaust may emit white smoke.

Troubleshooting:

Perform the following diagnostic procedure: "Air Inlet Heater Circuit - Test"

Results:

- OK – STOP.

i01387630

0070-06 Inlet Air Heater Short Circuit (49)

SMCS Code: 1090-038; 1408-081

Conditions Which Generate This Code:

The ECM has detected an open circuit or an short circuit after attempting to activate the air inlet heater.

System Response:

Electronic System Response The ECM is unable to activate the air inlet heater.

Engine Response The engine may be difficult to start in the cold temperature and the exhaust may emit white smoke.

Troubleshooting:

Perform the following diagnostic procedure: "Air Inlet Heater Circuit - Test"

Results:

- OK – STOP.

i01638606

0071-00 Idle Shutdown Override (01)

SMCS Code: 1900-038; 1901-038

Conditions Which Generate This Code:

The brake pedal or the clutch pedal is depressed during the last 90 seconds of the idle shutdown mode after the Check Engine Lamp begins to flash. The "Allow Idle Shutdown Override" parameter must be programmed to "YES".

Note: This diagnostic code represents an event. This diagnostic code does not represent an electronic system fault.

System Response:

Electronic System Response The idle shutdown timer stops counting. The idle shutdown timer will not begin counting again for shutdown until the vehicle is moved and the accelerator pedal is depressed. The diagnostic code requires Customer Passwords in order to be cleared from memory.

Service Tool Display or Lamps Caterpillar Electronic Technician (ET) will display "OVERRIDE" next to "Idle Shutdown" on the status screen. This code does not illuminate the Check Engine Lamp.

Engine Response The only effect on engine response is the fact that the engine will not shut down until the timer has been reset. The timer is reset by moving the vehicle or cycling the keyswitch. The timer can also be reset by quickly depressing the accelerator pedal and quickly releasing the accelerator pedal.

Note: The Timer cannot be overridden by using the service brakes or by using the clutch if the "Allow Idle Shutdown Override" parameter is programmed to NO.

Troubleshooting:

Perform the following diagnostic procedure: "Idle Shutdown Timer - Test"

Results:

- OK – STOP.

i01638636

0071-01 Idle Shutdown Occurrence (47)

SMCS Code: 1900

Conditions Which Generate This Code:

The idle timer has expired and the engine has shut down.

Note: This code represents an event. This code does not represent an electronic system fault.

System Response:

Electronic System Response The ECM remains powered after the engine shutdown.

Service Tool Display or Lamps During the final 90 seconds of counting, the Check Engine Lamp will flash. Customer Passwords are required to clear this diagnostic code.

Engine Response The engine is shut down.

Troubleshooting:

Perform the following diagnostic procedure: "Idle Shutdown Timer - Test"

Results:

- OK – STOP.

i01638645

0071-14 PTO Shutdown Timer Occurrence (47)

SMCS Code: 1900

Conditions Which Generate This Code:

The timer for the PTO has expired and the engine has shut down.

Note: This code represents an event. This code does not represent an electronic system fault.

System Response:

Electronic System Response The ECM remains powered after the engine shutdown.

Service Tool Display or Lamps Caterpillar Electronic Technician (ET) will display "NOT ACTIVE" next to "PTO Shutdown" on the status screen. During the final 90 seconds of counting, the Check Engine Lamp will flash and the PTO Switch On Lamp will flash. Customer Passwords are required to clear this diagnostic code.

Engine Response The engine is shut down.

Troubleshooting:

Perform the following diagnostic procedure: "PTO Shutdown Timer - Test"

Results:

- OK – STOP.

i01638652

0084-00 Vehicle Overspeed Warning (41)

SMCS Code: 1900

Conditions Which Generate This Code:

The vehicle speed has exceeded the programmed vehicle speed limit by more than ten mph for at least 20 seconds. This diagnostic code will not occur if the other vehicle speed circuit diagnostic codes are active.

Note: This code represents a critical event. This code does not represent an electronic system fault.

System Response:

Electronic System Response The ECM will stop fueling the injectors while the diagnostic code is active. This diagnostic code requires a Customer Password in order to be cleared.

Service Tool Display or Lamps Caterpillar Electronic Technician (ET) will display "VEHICLE SPEED LIMIT" on the status screen when the vehicle speed limit is met or the vehicle speed limit is exceeded.

Engine Response The engine is not fueled until the vehicle speed is reduced.

Troubleshooting:

This diagnostic code represents an event. This diagnostic code does not represent an electronic system fault. There are no problems that require troubleshooting.

Expected Result:**Results:**

- OK – STOP.

0084-01 Loss of Vehicle Speed Signal (31)

i01638665

SMCS Code: 1900**Conditions Which Generate This Code:**

The ECM does not detect vehicle speed when conditions indicate that vehicle speed should be present. This diagnostic code will not occur if the "VSL Protection" parameter is programmed to 2120 rpm.

System Response:

Electronic System Response The ECM will limit engine rpm to the programmed "VSL Protection". If the ECM is providing the speedometer signal, the speedometer will reflect the loss of speed when the vehicle is moving and the problem occurs.

Service Tool Display or Lamps Caterpillar Electronic Technician (ET) will display "DIAG" next to "Vehicle Speed" on the status screen while the diagnostic code is active. The Check Engine Lamp will illuminate.

Engine Response The driver may think that the engine power is low and that the engine is unable to reach the expected rpm.

Note: A fuel system restriction has been known to cause this diagnostic code although this occurrence is not common. This situation exists because the injectors are unable to provide sufficient fuel in order to achieve the desired rpm under normal load conditions. Because the ECM cannot reach the desired rpm under the normal load conditions, the ECM suspects that the vehicle is under load. This should only occur when the vehicle is in motion.

Troubleshooting:

Check the fuel pressure in order to ensure that a fuel system restriction is not the cause of the problem when the vehicle is not moving.

Perform the following diagnostic procedure: "Vehicle Speed and Speedometer Circuit - Test"

Results:

- OK – STOP.

i01638676

0084-02 Invalid Vehicle Speed Signal (36)

SMCS Code: 1900**Conditions Which Generate This Code:**

The "VSL Protection" is programmed less than 2120 rpm, and the vehicle speed is constant when the engine parameters indicate that the vehicle speed should be changing. This diagnostic code will not occur if the "VSL Protection" parameter is programmed to 2120 rpm.

Note: This code typically occurs when someone has tampered with the vehicle speed signal.

System Response:

Electronic System Response Engine rpm is limited to the programmed "VSL Protection" for one hour. If the ECM is providing the speedometer signal, the speedometer will reflect the loss of speed when the problem occurs and the vehicle is moving.

Service Tool Display or Lamps Caterpillar Electronic Technician (ET) will display "DIAG" next to "Vehicle Speed" on the status screen while the diagnostic code is active.

Engine Response The driver may think that the engine power is low and that the engine is unable to reach the expected rpm. The derate will remain for one hour after the fault is no longer active.

Troubleshooting:

Perform the following diagnostic procedure: "Vehicle Speed and Speedometer Circuit - Test"

Results:

- OK – STOP.

i01638681

0084-08 Vehicle Speed Out of Range (36)

SMCS Code: 1900**Conditions Which Generate This Code:**

The "VSL Protection" parameter is programmed less than 2120 rpm and the vehicle speed is greater than 204 km/h (127 mph) for at least two seconds. This diagnostic code will not occur if the "VSL Protection" parameter is programmed to 2120 rpm.

System Response:

Electronic System Response Vehicle speed is set to 0 km/h (0 mph) and engine rpm is limited to the programmed "VSL Protection". If the ECM is providing the speedometer signal, the speedometer will reflect the loss of speed when the problem occurs and the vehicle is moving.

Service Tool Display or Lamps Caterpillar Electronic Technician (ET) will display "DIAG" next to "Vehicle Speed" on the status screen while the diagnostic code is active. The Check Engine Lamp will illuminate.

Engine Response The driver may think that the engine power is low and that the engine is unable to reach the expected rpm.

Troubleshooting:

Perform the following diagnostic procedure: "Vehicle Speed and Speedometer Circuit - Test"

Results:

- OK – STOP.

i01638687

0084-10 Vehicle Speed Rate of Change (36)

SMCS Code: 1900

Conditions Which Generate This Code:

This condition involves the vehicle speed that is changing at an impossible rate. This diagnostic code will not occur if the "VSL Protection" parameter is programmed to 2120 rpm.

System Response:

Electronic System Response Engine rpm is limited to the programmed "VSL Protection".

Service Tool Display or Lamps Caterpillar Electronic Technician (ET) will display "DIAG" next to "Vehicle Speed" on the status screen while the diagnostic code is active. The Check Engine Lamp will illuminate.

Engine Response The driver may think that the engine power is low and that the engine is unable to reach the expected rpm.

Troubleshooting:

Perform the following diagnostic procedure: "Vehicle Speed and Speedometer Circuit - Test"

Results:

- OK – STOP.

i01638694

0091-08 Invalid Throttle Signal (32)

SMCS Code: 1913-038

Conditions Which Generate This Code:

The ECM is not receiving a correct accelerator pedal position signal.

System Response:

Electronic System Response The ECM returns the engine to low idle when the problem is detected.

Service Tool Display or Lamps Caterpillar Electronic Technician (ET) will display "0%" and "DIAG" next to "Throttle Position" on the status screen while the diagnostic code is active. The Check Engine Lamp will illuminate.

Engine Response The engine will remain at low idle while the diagnostic code is active.

Troubleshooting:

This diagnostic code is likely to be caused by an open circuit in the signal circuit for the accelerator pedal position, or a significant change in the signal frequency.

Perform the following diagnostic procedure: "Accelerator Pedal (Throttle) Position Sensor Circuit - Test"

Results:

- OK – STOP.

i01638698

0091-13 Throttle Sensor Calibration (28)

SMCS Code: 1913-524

Conditions Which Generate This Code:

The duty cycle for the Accelerator Pedal Position Sensor signal is less than 5 percent or more than 95 percent.

System Response:

Electronic System Response The ECM returns the engine to low idle when the problem is detected.

Service Tool Display or Lamps Caterpillar Electronic Technician (ET) will display "0%" and "DIAG" next to "Throttle Position" on the status screen while the diagnostic code is active.

Engine Response The engine will remain at low idle while the diagnostic code is active.

Troubleshooting:

Perform the following diagnostic procedure: "Accelerator Pedal (Throttle) Position Sensor Circuit - Test"

Results:

- OK – STOP.

i01616081

0096-03 Primary Fuel Level Sensor Open Circuit (44)

SMCS Code: 1408-081; 7483-038-NS

Conditions Which Generate This Code:

This diagnostic code is used only by GMT-560 applications.

The Primary Fuel Level signal voltage is above the acceptable range for more than 10 seconds.

System Response:

Electronic System Response If the parameter "Secondary Fuel Tank Size" is programmed and a diagnostic code for the secondary fuel level sensor is not active, the ECM will use the secondary fuel level sensor to determine the fuel level.

If the parameter "Secondary Fuel Tank Size" is not programmed and a diagnostic code is active for the secondary fuel level sensor, the ECM will broadcast an error code over the J1939 data link. The ECM will also broadcast the fuel level as 0 over the ATA data link.

Service Tool Display or Lamps Caterpillar Electronic Technician (ET) will display "DIAG" next to "Primary Fuel Level" on the status screen while the diagnostic code is active.

Perform the following diagnostic procedure: "Fuel Level Sensor Circuit - Test"

Results:

- OK – STOP.

i01616821

0096-04 Primary Fuel Level Sensor Short Circuit (44)

SMCS Code: 1408-081; 7483-038-NX

Conditions Which Generate This Code:

This diagnostic code is used only by GMT-560 applications.

The Primary Fuel Level signal voltage is below the acceptable range for more than 10 seconds.

System Response:

Electronic System Response If the parameter "Secondary Fuel Tank Size" is programmed and a diagnostic code for the secondary fuel level sensor is not active, the ECM will use the secondary fuel level sensor to determine the fuel level.

If the parameter "Secondary Fuel Tank Size" is not programmed and a diagnostic code is active for the secondary fuel level sensor, the ECM will broadcast an error code over the J1939 data link. The ECM will also broadcast the fuel level as 0 over the ATA data link.

Service Tool Display or Lamps Caterpillar Electronic Technician (ET) will display "DIAG" next to "Primary Fuel Level" on the status screen while the diagnostic code is active.

Perform the following diagnostic procedure: "Fuel Level Sensor Circuit - Test"

Results:

- OK – STOP.

i01638712

0100-03 Oil Pressure Sensor Open Circuit (24)

SMCS Code: 1408-081; 1924-038

Conditions Which Generate This Code:

The oil pressure signal voltage is above the acceptable range.

System Response:

Electronic System Response Oil pressure is set to 600 kPa (87 psi).

Service Tool Display or Lamps Caterpillar Electronic Technician (ET) will indicate 600 kPa (87 psi) and display "DIAG" next to "Engine Oil Pressure" on the status screen while the diagnostic code is active. The Check Engine Lamp will illuminate.

Engine Response The engine may experience low power when the diagnostic code is active.

Troubleshooting:

Perform the following diagnostic procedure: "Engine Pressure Sensor Open or Short Circuit - Test"

Results:

- OK – STOP.

i01638715

0100-04 Oil Pressure Sensor Short Circuit (24)

SMCS Code: 1408-081; 1924-038

Conditions Which Generate This Code:

The oil pressure signal voltage is below the acceptable range.

System Response:

Electronic System Response Oil pressure is set to 600 kPa (87 psi).

Service Tool Display or Lamps Caterpillar Electronic Technician (ET) will indicate 600 kPa (87 psi) and display "DIAG" next to "Engine Oil Pressure" on the status screen while the diagnostic code is active. The Check Engine Lamp will illuminate.

Engine Response The engine may experience low power when the diagnostic code is active.

Troubleshooting:

Perform the following diagnostic procedure: "Engine Pressure Sensor Open or Short Circuit - Test"

Results:

- OK – STOP.

i01599056

0100-11 Very Low Oil Pressure (46)

SMCS Code: 1924-038

Conditions Which Generate This Code:

Oil pressure is extremely low. "Engine Monitoring" must be programmed to "WARNING", "DERATE", or "SHUTDOWN" before this diagnostic code can occur.

Note: This diagnostic code represents a critical event. This diagnostic code does not represent an electronic system fault.

System Response:

Electronic System Response The ECM response depends on the programming of the Customer Parameter for "Engine Monitoring". The event code will be logged if the "Engine Monitoring" is not programmed "OFF".

This diagnostic code requires a Customer Password in order to be cleared.

If "Engine Monitoring" is programmed to "WARNING", The Check Engine Lamp will flash and the Warning Lamp will illuminate continuously.

If "Engine Monitoring" is programmed to "DERATE" or "SHUTDOWN", the Check Engine Lamp and the Warning Lamp will flash.

Service Tool Display or Lamps Caterpillar Electronic Technician (ET) will indicate "LOW OIL PRESSURE" in a unique area of the screen. ET will also display "DIAG" next to "Engine Oil Pressure" on the status screen while the diagnostic code is active.

Engine Response If the "Engine Monitoring" is programmed to "WARNING", there is no effect on engine power.

If the "Engine Monitoring" is programmed to "DERATE" or "SHUTDOWN", engine speed is limited to a maximum of 1350 rpm. The vehicle speed is limited to a maximum of 72 km/h (45 mph), and the power is limited. The engine will shut down if the conditions exist for a long enough period in the SHUTDOWN mode.

Troubleshooting:

This diagnostic code indicates very low oil pressure. This diagnostic code does not indicate a problem with the ECM or the oil pressure sensor. Refer to graphs for oil pressure that are shown in Troubleshooting, "System Overview".

Test Step 1. Check for Diagnostic Codes.

- A. Connect Caterpillar Electronic Technician (ET) to the service tool connector.
- B. Turn the keyswitch to the ON position. The engine should be off.
- C. Check for any active diagnostic codes or logged diagnostic codes.

Expected Result:

There should be no diagnostic codes that are present.

Results:

- OK – Proceed to Test Step 2.
- Not OK

Repair: Repair the diagnostic codes that are present. Refer to the appropriate topic in the "Troubleshooting With a Diagnostic Code" section of this manual.

Ensure that the repair eliminates the problem.

STOP.

Test Step 2. Check the Engine Oil Pressure Sensor.

- A. Connect ET to the cab data link connector.
- B. Turn the ignition key switch to the ON position.
- C. The status screen will display the pressure reading from the sensor. The pressure reading for the engine oil pressure sensor should be less than 21 kPa (3 psi).

- D. Use the 1U-5470 Engine Pressure Group to measure the engine oil pressure on the right side engine high pressure oil gallery. Select a port that is located near the engine oil pressure sensor, but not the sensor port.
- E. Start the engine and run at low idle. If the engine oil pressure does not exceed 35 kPa (5 psi) after five seconds, stop the engine.
- F. Depress the accelerator pedal to the high idle position and check for oil leakage. Repair any leaks.
- G. Operate the engine at low idle, at 1200 rpm and at high idle in order to compare the engine oil pressure from the status screen to the 1U-5470 Engine Pressure Group measurement at each rpm.

Expected Result:

The ET display and the measured engine oil pressure from the 1U-5470 Engine Pressure Group are within 35 kPa (5 psi) of each other.

Results:

- Yes – The sensor is functioning correctly. If a problem is still suspected the problem is a mechanical problem. The problem is not an electronic problem.

Repair: Perform the following diagnostic procedure:

Refer to Troubleshooting, "Troubleshooting without a Diagnostic Code" for a procedure that best describes the conditions.

STOP.

- No

Repair: Perform the following diagnostic procedure:

1. Temporarily install another sensor.
2. Repeat this test step.
3. If the problem is resolved with the new sensor, replace the sensor.
4. Verify that the repair eliminates the problem.

STOP.

i01226387

0102-00 Boost Pressure Reading Stuck High (25)

SMCS Code: 1917-038

Conditions Which Generate This Code:

The Boost Pressure is higher than the boost pressure that is required for normal operating conditions.

Note: This diagnostic code represents an event. This diagnostic code does not represent an Electronic System Fault.

System Response:

Electronic System Response Boost Pressure is set to 0 kPa (0 psi).

Service Tool Display or Lamps The Electronic Service Tool will indicate 0 kPa (0 psi) while the Diagnostic Code is Active and "DIAG" will be displayed on the Status Screen.

Engine Response The engine may experience low power when the Diagnostic Code is Active.

Troubleshooting:

Determine the cause of the excessive boost pressure such as a wastegate for the turbocharger that has failed or a line for the wastegate that has been pinched.

Results:

- OK – STOP.

i01638732

0102-03 Boost Pressure Sensor Open Circuit (25)

SMCS Code: 1408-081; 1917-038

Conditions Which Generate This Code:

The boost pressure signal voltage is above the acceptable range.

System Response:

Electronic System Response Boost pressure is set to 0 kPa (0 psi).

Service Tool Display or Lamps Caterpillar Electronic Technician (ET) will indicate 0 kPa (0 psi) and display "DIAG" next to "Boost Pressure" on the status screen while the diagnostic code is active. The Check Engine Lamp will illuminate.

Engine Response The engine may experience low power when the diagnostic code is active.

Troubleshooting:

Perform the following diagnostic procedure: "Engine Pressure Sensor Open or Short Circuit - Test"

Results:

- OK – STOP.

i01638738

0102-04 Boost Pressure Sensor Short Circuit (25)

SMCS Code: 1408-081; 1917-038

Conditions Which Generate This Code:

The boost pressure signal voltage is below the acceptable range.

System Response:

Electronic System Response Boost pressure is set to 0 kPa (0 psi).

Service Tool Display or Lamps Caterpillar Electronic Technician (ET) will indicate 0 kPa (0 psi) and display "DIAG" next to "Boost Pressure" on the status screen while the diagnostic code is active. The Check Engine Lamp will illuminate.

Engine Response The engine may experience low power when the diagnostic code is active.

Troubleshooting:

Perform the following diagnostic procedure: "Engine Pressure Sensor Open or Short Circuit - Test"

Results:

- OK – STOP.

i01638741

0102-07 Excessive Boost Pressure

SMCS Code: 1917-038

Conditions Which Generate This Code:

The boost pressure is higher than the boost pressure that is required for normal operating conditions.

Note: The diagnostic code indicates a mechanical problem. The ECM and the electronic control system is operating correctly.

System Response:

Electronic System Response Boost pressure is set to 0 kPa (0 psi).

Service Tool Display or Lamps Caterpillar Electronic Technician (ET) will indicate 0 kPa (0 psi) and display "DIAG" next to "Boost Pressure" on the status screen while the diagnostic code is active. The Check Engine Lamp will illuminate.

Engine Response The engine may experience low power when the diagnostic code is active.

Troubleshooting:

The diagnostic code indicates a problem with the turbocharger, the wastegate, or a pinched turbocharger line. The diagnostic code does not indicate a problem with the ECM or the electronic control system.

Results:

- OK – STOP.

i01599498

0105-00 High Inlet Manifold Temp Warning (64)

SMCS Code: 1921-038

Conditions Which Generate This Code:

The engine has been running for at least 30 seconds.

The coolant temperature is above 99 °C (210 °F).

The air temperature for the air inlet manifold is equal to 90 °C (194 °F) or above 90 °C (194 °F). "Engine Monitoring" must be programmed to "WARNING", "DERATE", or "SHUTDOWN" before this diagnostic code can occur.

Note: This diagnostic code represents an critical event. This diagnostic code does not represent an electronic system fault.

System Response:

Electronic System Response The ECM does not derate the power. Also, the ECM does not limit the engine rpm or the vehicle speed due to this diagnostic code.

The Check Engine Lamp will flash.

The Warning Lamp will illuminate if the "Engine Monitoring" is programmed to "WARNING", "DERATE", or "SHUTDOWN".

This diagnostic code requires a Customer Password in order to be cleared.

Service Tool Display or Lamps Caterpillar Electronic Technician (ET) will display "DIAG" next to "Intake Manifold Air Temperature" on the status screen while the diagnostic code is active.

Engine Response This diagnostic code does not affect engine power.

Troubleshooting:

This diagnostic code indicates an excessive temperature in the air inlet manifold. This diagnostic code does not indicate a problem with the ECM or a problem with the temperature sensor for the air inlet manifold.

Test Step 1. Check for Diagnostic Codes.

- Connect ET to the cab data link connector.
- Turn the keyswitch to the ON position. The engine should be off.
- Check for any active diagnostic codes or logged diagnostic codes.

Expected Result:

There should be no diagnostic codes that are present.

Results:

- OK – Proceed to Test Step 2.
- Not OK

Repair: Repair the diagnostic codes that are present. For further details, refer to Troubleshooting, "Troubleshooting With a Diagnostic Code".

Ensure that the repair eliminates the problem.

STOP.

Test Step 2. Inspect Electrical Connectors and Wiring.

A. Thoroughly inspect the following connectors:

- J2/P2 ECM engine harness connector
- J1/P1 ECM vehicle harness connector
- connector terminals for the sensor

Refer to Troubleshooting, "Electrical Connectors - Inspect" for details.

B. Perform a 45 N (10 lb) pull test on each of the wires in the ECM connector that are associated with the appropriate diagnostic code.

C. Check the ECM connector (allen head screw) for the proper torque of 6.0 N·m (55 lb in).

D. Check the harness and wiring for abrasion and pinch points from the appropriate sensor back to the ECM.

Expected Result:

All connectors, pins and sockets should be completely coupled and/or inserted and the harness and wiring should be free of corrosion, abrasion or pinch points.

Choose the OK option in order to select the sensor that requires troubleshooting or select the NOT OK option if the wiring is causing the problem.

Results:

- OK – Proceed to Test Step 3.
- Not OK – Repair the connectors or wiring and/or replace the connectors or wiring. Ensure that all of the seals are properly in place and ensure that the connectors are completely coupled. Verify that the repair eliminates the problem. STOP.

Test Step 3. Check the Sensor in the Engine.

A. Ensure that the temperature of the engine is cool before starting this procedure.

B. Connect ET to the cab data link connector.

C. Turn the ignition key switch to the ON position.

D. Note the temperature for the sensor on the ET status screen .

E. Start the engine but remain parked.

F. Monitor the temperature for the sensor on the ET status screen as the engine is warming.

Expected Result:

The temperature before starting the engine should be within reasonable limits, and the temperature increases as the engine warms.

Note: The engine may require several hours to cool down depending on the ambient air temperature around the vehicle.

Results:

- Yes – The sensor is functioning correctly. If a problem is still suspected the problem is a mechanical problem. The problem is not an electronic problem.

Repair: Perform the following diagnostic procedure:

Refer to Troubleshooting, "Troubleshooting without a Diagnostic Code" for a procedure that best describes the conditions.

STOP.

- No – Proceed to Test Step 4.

Test Step 4. Compare the Temperature Reading to the Temperature from Another Gauge.

A. Remove the temperature sensor from the engine.

B. Connect the sensor to the engine harness. Hold the sensor and the thermocouple probe from the 6V-9130 Temperature Adapter in the air. Allow three minutes for the sensor and the probe to respond to the temperature of the air.

C. The ET status screen will display the temperature reading from the sensor. Compare the temperature reading to the temperature reading from the 6V-9130 Temperature Adapter.

D. Hold the sensor and the thermocouple probe in your hand and check the temperatures again. Do not expose the sensor to a flame.

Expected Result:

The two measurements are within 15 °C (27 °F) of each other.

Note: Do not expect the sensor and the thermocouple probe from the 6V-9130 Temperature Adapter to respond to the temperature change at the same rate.

Results:

- **Yes** – The sensor is functioning correctly. If a problem is still suspected the problem is a mechanical problem. The problem is not an electronic problem.

Repair: Perform the following diagnostic procedure:

Refer to Troubleshooting, "Troubleshooting without a Diagnostic Code" for a procedure that best describes the conditions.

STOP.

- **No**

Repair: Perform the following diagnostic procedure:

1. Temporarily install another sensor.
2. Repeat this test step.
3. If the problem is resolved with the new sensor, replace the sensor.
4. Verify that the repair eliminates the problem.

STOP.

i01638750

0105-03 Inlet Manifold Temp Sensor Open Circuit (38)

SMCS Code: 1408-081; 1921-038

Conditions Which Generate This Code:

The Air Temperature signal voltage for the inlet air temperature sensor is above the acceptable range.

System Response:

Electronic System Response The Inlet Manifold Air Temperature is set to 85 °C (185 °F) while the diagnostic code is active.

Service Tool Display or Lamps Caterpillar Electronic Technician (ET) will indicate 85 °C (185 °F) and display "DIAG" next to "Intake Manifold Air Temperature" on the status screen while the diagnostic code is active. The Check Engine Lamp will NOT illuminate unless this diagnostic code has been active for 10 hours.

Engine Response Occasionally, the engine may emit white smoke on start-up and misfire during cold ambient air temperatures.

Troubleshooting:

Perform the following diagnostic procedure: "Engine Temperature Sensor Open or Short Circuit - Test"

Results:

- **OK** – STOP.

i01638755

0105-04 Inlet Manifold Temp Sensor Short Circuit (38)

SMCS Code: 1408-081; 1921-038

Conditions Which Generate This Code:

The Air Temperature signal voltage for the inlet air temperature sensor is below the acceptable range.

System Response:

Electronic System Response The inlet manifold air temperature is set to 85 °C (185 °F) while the diagnostic code is active.

Service Tool Display or Lamps Caterpillar Electronic Technician (ET) will indicate 85 °C (185 °F) and display "DIAG" next to "Intake Manifold Air Temperature" on the status screen while the diagnostic code is active. The Check Engine Lamp will NOT illuminate unless this diagnostic code has been active for 10 hours.

Engine Response Occasionally, the engine may emit white smoke on start-up and misfire during cold ambient air temperatures.

Troubleshooting:

Perform the following diagnostic procedure: "Engine Temperature Sensor Open or Short Circuit - Test"

Results:

- **OK** – STOP.

i01599629

0105-11 Very High Inlet Manifold Temp (64)

SMCS Code: 1921-038

Conditions Which Generate This Code:

The engine has been running for at least 30 seconds.

The coolant temperature is above 99 °C (210 °F).

The air temperature for the air inlet manifold is at 110 °C (230 °F) or above 110 °C (230 °F).

Note: This diagnostic code represents a critical event. This diagnostic code does not represent an electronic system fault.

System Response:

Electronic System Response The ECM response depends on the programming of the Customer Parameter for "Engine Monitoring". The event code will be logged if the "Engine Monitoring" is not programmed "OFF".

The Check Engine Lamp will flash.

If "Engine Monitoring" is programmed to "WARNING", The Check Engine Lamp will flash and the Warning Lamp will illuminate continuously.

If "Engine Monitoring" is programmed to "DERATE" or "SHUTDOWN", the Check Engine Lamp and the Warning Lamp will flash.

This diagnostic code requires a Customer Password in order to be cleared.

Service Tool Display or Lamps Caterpillar Electronic Technician (ET) will display "DIAG" next to "Intake Manifold Air Temperature" on the status screen while the diagnostic code is active.

Engine Response If the "Engine Monitoring" is programmed to "WARNING", there is no effect on engine power.

If the "Engine Monitoring" is programmed to "DERATE" or "SHUTDOWN", engine speed is limited to a maximum of 1350 rpm. The vehicle speed is limited to a maximum of 72 km/h (45 mph), and the power is limited. The engine will shut down if the conditions exist for a long enough period in the "SHUTDOWN" mode.

Troubleshooting:

This diagnostic code indicates an excessive temperature in the air inlet manifold. This diagnostic code does not indicate a problem with the ECM or a problem with the temperature sensor for the air inlet manifold.

Test Step 1. Check for Diagnostic Codes.

- A. Connect ET to the cab data link connector.
- B. Turn the keyswitch to the ON position. The engine should be off.
- C. Check for any active diagnostic codes or logged diagnostic codes.

Expected Result:

There should be no diagnostic codes that are present.

Results:

- OK – Proceed to Test Step 2.
- Not OK

Repair: Repair the diagnostic codes that are present. For further details, refer to Troubleshooting, "Troubleshooting With a Diagnostic Code".

Ensure that the repair eliminates the problem.

STOP.

Test Step 2. Inspect Electrical Connectors And Wiring.

A. Thoroughly inspect the following connectors:

- J2/P2 ECM engine harness connector
- J1/P1 ECM vehicle harness connector
- connector terminals for the sensor

Refer to Troubleshooting, "Electrical Connectors - Inspect" for details.

- B. Perform a 45 N (10 lb) pull test on each of the wires in the ECM connector that are associated with the appropriate diagnostic code.
- C. Check the ECM connector (allen head screw) for the proper torque of 6.0 N·m (55 lb in).

- D.** Check the harness and wiring for abrasion and pinch points from the appropriate sensor back to the ECM.

Expected Result:

All connectors, pins and sockets should be completely coupled and/or inserted and the harness and wiring should be free of corrosion, abrasion or pinch points.

Choose the OK option in order to select the sensor that requires troubleshooting or select the NOT OK option if the wiring is causing the problem.

Results:

- **OK** – Proceed to Test Step 3.
- **Not OK** – Repair the connectors or wiring and/or replace the connectors or wiring. Ensure that all of the seals are properly in place and ensure that the connectors are completely coupled. Verify that the repair eliminates the problem. **STOP.**

Test Step 3. Check the Sensor In The Engine.

- A.** Ensure that the temperature of the engine is cool before starting this procedure.
- B.** Connect ET to the cab data link connector.
- C.** Turn the ignition key switch to the ON position.
- D.** Note the temperature for the sensor on the ET status screen.
- E.** Start the engine but remain parked.
- F.** Monitor the temperature for the sensor on the ET status screen as the engine is warming.

Expected Result:

The temperature before starting the engine should be within reasonable limits, and the temperature increases as the engine warms.

Note: The engine may require several hours to cool down depending on the ambient air temperature around the vehicle.

Results:

- **Yes** – The sensor is functioning correctly. If a problem is still suspected the problem is a mechanical problem. The problem is not an electronic problem.

Repair: Perform the following diagnostic procedure:

Refer to Troubleshooting, “Troubleshooting without a Diagnostic Code” for a procedure that best describes the conditions.

STOP.

- **No** – Proceed to Test Step 4.

Test Step 4. Compare The Temperature Reading To The Temperature From Another Gauge.

- A.** Remove the temperature sensor from the engine.
- B.** Connect the sensor to the engine harness. Hold the sensor and the thermocouple probe from the **6V-9130** Temperature Adapter in the air. Allow three minutes for the sensor and the probe to respond to the temperature of the air.
- C.** The ET status screen will display the temperature reading from the sensor. Compare the temperature reading to the temperature reading from the **6V-9130** Temperature Adapter.
- D.** Hold the sensor and the thermocouple probe in your hand and check the temperatures again. Do not expose the sensor to a flame.

Expected Result:

The two measurements are within 15 °C (27 °F) of each other.

Note: Do not expect the sensor and the thermocouple probe from the **6V-9130** Temperature Adapter to respond to the temperature change at the same rate.

Results:

- **Yes** – The sensor is functioning correctly. If a problem is still suspected the problem is a mechanical problem. The problem is not an electronic problem.

Repair: Perform the following diagnostic procedure:

Refer to Troubleshooting, “Troubleshooting without a Diagnostic Code” for a procedure that best describes the conditions.

STOP.

- **No**

Repair: Perform the following diagnostic procedure:

- 1.** Temporarily install another sensor.
- 2.** Repeat this test step.

3. If the problem is resolved with the new sensor, replace the sensor.

4. Verify that the repair eliminates the problem.

STOP.

i01638773

0108-03 Atmospheric Pressure Sensor Open Circuit (26)

SMCS Code: 1408-081; 1923-038

Conditions Which Generate This Code:

The atmospheric pressure signal voltage is above the acceptable range.

System Response:

Electronic System Response Atmospheric pressure is set to 100 kPa (15 psi).

Service Tool Display or Lamps Caterpillar Electronic Technician (ET) will indicate 100 kPa (15 psi) and display "DIAG" next to "Atmospheric Pressure" on the status screen while the diagnostic code is active. The Check Engine Lamp will illuminate.

Engine Response The engine may experience low power when the diagnostic code is active.

Troubleshooting:

Perform the following diagnostic procedure: "Engine Pressure Sensor Open or Short Circuit - Test"

Results:

- OK – STOP.

i01638779

0108-04 Atmospheric Pressure Sensor Short Circuit (26)

SMCS Code: 1408-081; 1923-038

Conditions Which Generate This Code:

The atmospheric pressure signal voltage is below the acceptable range.

System Response:

Electronic System Response Atmospheric pressure is set to 100 kPa (15 psi).

Service Tool Display or Lamps Caterpillar Electronic Technician (ET) will indicate 100 kPa (15 psi) and display "DIAG" next to "Atmospheric Pressure" on the status screen while the diagnostic code is active. The Check Engine Lamp will illuminate.

Engine Response The engine may experience low power when the diagnostic code is active.

Troubleshooting:

Perform the following diagnostic procedure: "Engine Pressure Sensor Open or Short Circuit - Test"

Results:

- OK – STOP.

i01598565

0110-00 High Coolant Temperature Warning (61)

SMCS Code: 1906-038

Conditions Which Generate This Code:

The engine has been running for at least 30 seconds.

The diagnostic codes for the coolant temperature are not active.

The coolant temperature is equal to 108 °C (226 °F) or above 108 °C (226 °F). For emergency vehicles, the coolant temperature is equal to 113 °C (235 °F) or above 113 °C (235 °F).

"Engine Monitoring" must be programmed to "WARNING", "DERATE", or "SHUTDOWN" before this diagnostic code can occur.

Note: This diagnostic code represents an event. This diagnostic code does not represent an electronic system fault.

System Response:

Electronic System Response For "Engine Monitoring" that is programmed to "DERATE" or "SHUTDOWN", the ECM begins to derate the power. The ECM also limits the vehicle speed.

If "Engine Monitoring" is programmed to "WARNING", the check engine lamp will flash and the warning lamp will turn on continuously.

If “Engine Monitoring” is programmed to “DERATE” or “SHUTDOWN”, the check engine lamp and the warning lamp will flash.

This diagnostic code requires a customer password in order to be cleared.

Engine Response If “Engine Monitoring” is programmed to “WARNING” there is no effect on engine power.

If “Engine Monitoring” is programmed to “DERATE” or “SHUTDOWN”, the ECM begins limiting vehicle speed and power.

Troubleshooting:

This diagnostic code indicates an excessive coolant temperature. This diagnostic code does not indicate a problem with the ECM or a problem with the coolant temperature sensor.

Test Step 1. Check for Diagnostic Codes.

- A. Connect Caterpillar Electronic Technician (ET) to the cab data link connector.
- B. Turn the keyswitch to the ON position. The engine should be OFF.
- C. Check for any active diagnostic codes or logged diagnostic codes.

Expected Result:

There should be no diagnostic codes that are present.

Results:

- OK – Proceed to Test Step 2.
- Not OK

Repair: Repair the diagnostic codes that are present. Refer to the appropriate topic in the “Troubleshooting With a Diagnostic Code” section of this manual.

Ensure that the repair eliminates the problem.

STOP.

Test Step 2. Perform a Check of the Cooling System.

- A. Perform a check of the cooling system. Ensure that the coolant is at the proper level.

Expected Result:

There are no problems with the cooling system.

Results:

- OK – Proceed to Test Step 3.
- Not OK

Repair: Repair the problem.

Ensure that the repair eliminates the problem.

STOP.

Test Step 3. Inspect Electrical Connectors And Wiring.

- A. Thoroughly inspect the following connectors:

- J2/P2 ECM engine harness connector
- J1/P1 ECM vehicle harness connector
- connector terminals for the sensor

Refer to Troubleshooting, “Electrical Connectors - Inspect” for details.

- B. Perform a 45 N (10 lb) pull test on each of the wires in the ECM connector that are associated with the appropriate diagnostic code.
- C. Check the ECM connector (allen head screw) for the proper torque of 6.0 N·m (55 lb in).
- D. Check the harness and wiring for abrasion and pinch points from the appropriate sensor back to the ECM.

Expected Result:

All connectors, pins and sockets should be completely coupled and/or inserted and the harness and wiring should be free of corrosion, abrasion or pinch points.

Choose the OK option in order to select the sensor that requires troubleshooting or select the NOT OK option if the wiring is causing the problem.

Results:

- OK – Proceed to Test Step 4.
- Not OK – Repair the connectors or wiring and/or replace the connectors or wiring. Ensure that all of the seals are properly in place and ensure that the connectors are completely coupled. Verify that the repair eliminates the problem. STOP.

Test Step 4. Check the Sensor in the Engine.

- A. Ensure that the temperature of the engine is cool before starting this procedure.

- B. Connect ET to the cab data link connector.
- C. Turn the ignition key switch to the ON position.
- D. Note the temperature for the sensor on the ET status screen.
- E. Start the engine but remain parked.
- F. Monitor the temperature for the sensor that is being checked on the ET status screen as the engine is warming.

Expected Result:

The temperature before starting the engine should be within reasonable limits, and the temperature increases as the engine warms.

Note: The engine may require several hours to cool down depending on the ambient air temperature around the vehicle.

Results:

- **Yes** – The sensor is functioning correctly. If a problem is still suspected the problem is a mechanical problem. The problem is not an electronic problem.

Repair: Perform the following diagnostic procedure:

Refer to Troubleshooting, “Troubleshooting without a Diagnostic Code” for a procedure that best describes the conditions.

STOP.

- **No** – Proceed to Test Step 5.

Test Step 5. Compare the Temperature Reading to the Temperature from Another Gauge.

- A. Remove the temperature sensor from the engine.
- B. Connect the sensor to the engine harness. Insert the sensor and the thermocouple probe from the 6V-9130 Temperature Adapter into a container of water that is room temperature. Allow three minutes for the sensor and the probe to respond to the temperature of the water.
- C. The ET status screen will display the temperature reading from the sensor. Compare the temperature reading to the temperature reading from the 6V-9130 Temperature Adapter. The temperature reading from the sensor can also be compared to the temperature gauge on the dash of the truck.

- D. Insert the sensor and the thermocouple probe from the 6V-9130 Temperature Adapter into a container of hot water. Again, compare the temperature reading from the sensor to the temperature reading of the 6V-9130 Temperature Adapter.

Expected Result:

The two measurements are within 15 °C (27 °F) of each other.

Note: Do not expect the sensor and the thermocouple probe from the 6V-9130 Temperature Adapter to respond to the temperature change at the same rate.

Results:

- **Yes** – The sensor is functioning correctly. If a problem is still suspected the problem is a mechanical problem. The problem is not an electronic problem.

Repair: Perform the following diagnostic procedure:

Refer to Troubleshooting, “Troubleshooting without a Diagnostic Code” for a procedure that best describes the conditions.

STOP.

- **No**

Repair: Perform the following diagnostic procedure:

1. Temporarily install another sensor.
2. Repeat this test step.
3. If the problem is resolved with the new sensor, replace the sensor.
4. Verify that the repair eliminates the problem.

STOP.

i01638799

0110-03 Coolant Temp Sensor Open Circuit (27)

SMCS Code: 1408-081; 1906-038

Conditions Which Generate This Code:

The coolant temperature signal voltage is above the acceptable range.

System Response:

Electronic System Response Coolant temperature is set to 90 °C (194 °F) while the diagnostic code is active. Cold Mode is disabled. If the ECM is controlling the cooling fan, the fan will be ON.

Service Tool Display or Lamps Caterpillar Electronic Technician (ET) will indicate 90 °C (194 °F) and display “DIAG” next to “Engine Coolant Temperature” on the status screen while the diagnostic code is active. The Check Engine Lamp will NOT illuminate unless this diagnostic code has been continuously active for 10 hours.

Engine Response Occasionally, the engine may emit white smoke on start-up because Cold Mode is not active.

Troubleshooting:

Perform the following diagnostic procedure: “Engine Temperature Sensor Open or Short Circuit - Test”

Results:

- OK – STOP.

i01638815

0110-04 Coolant Temp Sensor Short Circuit (27)

SMCS Code: 1408-081; 1906-038

Conditions Which Generate This Code:

The coolant temperature signal voltage is below the acceptable range.

System Response:

Electronic System Response Coolant temperature is set to 90 °C (194 °F) while the diagnostic code is active. Cold Mode is disabled. If the ECM is controlling the cooling fan, the fan will be ON.

Service Tool Display or Lamps Caterpillar Electronic Technician (ET) will indicate 90 °C (194 °F) and display “DIAG” next to “Engine Coolant Temperature” on the status screen while the diagnostic code is active. The Check Engine Lamp will NOT illuminate unless this diagnostic code has been continuously active for 10 hours.

Engine Response Occasionally, the engine may emit white smoke on start-up because Cold Mode is not active.

Troubleshooting:

Perform the following diagnostic procedure: “Engine Temperature Sensor Open or Short Circuit - Test”

Results:

- OK – STOP.

i01600207

0110-11 Very High Coolant Temperature (61)

SMCS Code: 1906-038

Conditions Which Generate This Code:

The engine has been running for at least 30 seconds.

The diagnostic codes for the coolant temperature are not active.

The coolant temperature is equal to 111 °C (232 °F) or above 111 °C (232 °F). For emergency vehicles, the coolant temperature is equal to 116 °C (241 °F) or above 116 °C (241 °F).

“Engine Monitoring” must be programmed to “WARNING”, “DERATE”, or “SHUTDOWN” before this diagnostic code can occur.

Note: This diagnostic code represents an event. This diagnostic code does not represent an electronic system fault.

System Response:

Electronic System Response For “Engine Monitoring” that is programmed to “DERATE” or “SHUTDOWN”, the ECM begins to derate the power. The ECM also limits the vehicle speed.

If “Engine Monitoring” is programmed to “WARNING”, the check engine lamp will flash and the warning lamp will turn ON continuously.

If “Engine Monitoring” is programmed to “DERATE” or “SHUTDOWN”, the check engine lamp and the warning lamp will flash.

This diagnostic code requires a customer password in order to be cleared.

Engine Response If “Engine Monitoring” is programmed to “WARNING”, there is no effect on engine power.

If the “Engine Monitoring” is programmed to “DERATE” or “SHUTDOWN”, the vehicle speed is limited to a maximum of 72 km/h (45 mph) and the power is limited. The engine will shut down if conditions exist for a long enough period in the SHUTDOWN mode.

Troubleshooting:

This diagnostic code indicates an excessive coolant temperature. This diagnostic code does not indicate a problem with the ECM or a problem with the coolant temperature sensor.

Test Step 1. Check for Diagnostic Codes.

- A. Connect Caterpillar Electronic Technician (ET) to the cab data link connector.
- B. Turn the keyswitch to the ON position. The engine should be OFF.
- C. Check for any active diagnostic codes or logged diagnostic codes.

Expected Result:

There should be no diagnostic codes that are present.

Results:

- OK – Proceed to Test Step 2.
- Not OK

Repair: Repair the diagnostic codes that are present. Refer to the appropriate topic in the “Troubleshooting With a Diagnostic Code” section of this manual.

Ensure that the repair eliminates the problem.

STOP.

Test Step 2. Perform a Check of the Cooling System.

- A. Perform a check of the cooling system. Ensure that the coolant is at the proper level.

Expected Result:

There are no problems with the cooling system.

Results:

- OK – Proceed to Test Step 3.
- Not OK

Repair: Repair the problem.

Ensure that the repair eliminates the problem.

STOP.

Test Step 3. Inspect Electrical Connectors and Wiring.

- A. Thoroughly inspect the following connectors:

- J2/P2 ECM engine harness connector
- J1/P1 ECM vehicle harness connector
- connector terminals for the sensor

Refer to Troubleshooting, “Electrical Connectors - Inspect” for details.

- B. Perform a 45 N (10 lb) pull test on each of the wires in the ECM connector that are associated with the appropriate diagnostic code.
- C. Check the ECM connector (allen head screw) for the proper torque of 6.0 N·m (55 lb in).
- D. Check the harness and wiring for abrasion and pinch points from the appropriate sensor back to the ECM.

Expected Result:

All connectors, pins and sockets should be completely coupled and/or inserted and the harness and wiring should be free of corrosion, abrasion or pinch points.

Choose the OK option in order to select the sensor that requires troubleshooting or select the NOT OK option if the wiring is causing the problem.

Results:

- OK – Proceed to Test Step 4.
- Not OK – Repair the connectors or wiring and/or replace the connectors or wiring. Ensure that all of the seals are properly in place and ensure that the connectors are completely coupled. Verify that the repair eliminates the problem. STOP.

Test Step 4. Check the Sensor in the Engine.

- A. Ensure that the temperature of the engine is cool before starting this procedure.
- B. Connect ET to the cab data link connector.
- C. Turn the ignition key switch to the ON position.

- D. Note the temperature for the sensor on the ET status screen.
- E. Start the engine but remain parked.
- F. Monitor the temperature for the sensor that is being checked on the ET status screen as the engine is warming.

Expected Result:

The temperature before starting the engine should be within reasonable limits, and the temperature increases as the engine warms.

Note: The engine may require several hours to cool down depending on the ambient air temperature around the vehicle.

Results:

- **Yes** – The sensor is functioning correctly. If a problem is still suspected the problem is a mechanical problem. The problem is not an electronic problem.

Repair: Perform the following diagnostic procedure:

Refer to Troubleshooting, "Troubleshooting without a Diagnostic Code" for a procedure that best describes the conditions.

STOP.

- **No** – Proceed to Test Step 5.

Test Step 5. Compare the Temperature Reading to the Temperature from Another Gauge.

- A. Remove the temperature sensor from the engine.
- B. Connect the sensor to the engine harness. Insert the sensor and the thermocouple probe from the **6V-9130** Temperature Adapter into a container of water that is room temperature. Allow three minutes for the sensor and the probe to respond to the temperature of the water.
- C. The ET status screen will display the temperature reading from the sensor. Compare the temperature reading to the temperature reading from the **6V-9130** Temperature Adapter. The temperature reading from the sensor can also be compared to the temperature gauge on the dash of the truck.

- D. Insert the sensor and the thermocouple probe from the **6V-9130** Temperature Adapter into a container of hot water. Again, compare the temperature reading from the sensor to the temperature reading of the **6V-9130** Temperature Adapter.

Expected Result:

The two measurements are within 15 °C (27 °F) of each other.

Note: Do not expect the sensor and the thermocouple probe from the **6V-9130** Temperature Adapter to respond to the temperature change at the same rate.

Results:

- **Yes** – The sensor is functioning correctly. If a problem is still suspected the problem is a mechanical problem. The problem is not an electronic problem.

Repair: Perform the following diagnostic procedure:

Refer to Troubleshooting, "Troubleshooting without a Diagnostic Code" for a procedure that best describes the conditions.

STOP.

- **No**

Repair: Perform the following diagnostic procedure:

1. Temporarily install another sensor.
2. Repeat this test step.
3. If the problem is resolved with the new sensor, replace the sensor.
4. Verify that the repair eliminates the problem.

STOP.

i01724991

0111-01 Low Coolant Level Warning (62)

SMCS Code: 7422-038

Conditions Which Generate This Code:

This condition indicates that the coolant level is low. "Engine Monitoring" must be programmed to "WARNING", "DERATE", or "SHUTDOWN", and the parameter "Coolant Level Sensor" must be programmed to "4-pin", "2-pin switch", or "2-wire float sensor" before this diagnostic code can occur.

Note: This diagnostic code represents an event. This diagnostic code does not represent an electronic system fault.

System Response:

Electronic System Response The ECM does not derate the power. Also, the ECM does not limit the engine rpm or the vehicle speed due to this diagnostic code.

The Check Engine Lamp will flash and the Warning Lamp will illuminate.

This diagnostic code requires a Customer Password in order to be cleared.

Service Tool Display or Lamps The Caterpillar Electronic Technician (Cat ET) will indicate "LOW" and "DIAG" next to "Engine Coolant Level" on the status screen while the diagnostic code is active.

Engine Response This diagnostic code does not affect engine power.

Troubleshooting:

If the vehicle is equipped with the 2-Pin Switch, proceed with the following steps.

2-Pin Switch

GMT-560 applications have the option of using a 2-pin switch to monitor coolant level. To use a 2-pin switch, the parameter "Manufacturer/Model" must be programmed to "GMT-560" and the parameter "Coolant Level Sensor" must be programmed to "2-pin switch". The diagnostic fault codes for the coolant level sensors are disabled when the "Coolant Level Sensor" parameter is programmed to "2-pin switch". The switch is connected to P1/J1:49 (coolant level switch) and to P1/J1:5 (AP sensor/switch sensor common). If the coolant level is normal, the switch should be closed and P1/J1:49 connected to ground. The warning lamp will be illuminated via the J1939 data link when the coolant is low.

Test Step 1. Check the Level of the Coolant

Visually check the level of the coolant. Ensure that the coolant level switch is fully immersed in the coolant.

Expected Result:

The coolant is at the proper level.

Results:

- OK – Proceed to Test Step 2.
- Not OK

Repair: Fill the cooling system with the proper coolant to the correct level. For further information, refer to the Operations and Maintenance Manual.

STOP.

Test Step 2. Inspect Electrical Connectors and Wiring

A. Thoroughly inspect the following connectors:

- J1/P1 ECM vehicle harness connector
- Harness for the connector to the coolant level switch
- Connector terminals for the switch

Refer to Troubleshooting, "Electrical Connectors - Inspect" for details.

B. Perform a 45 N (10 lb) pull test on each of the wires in the ECM connector that are associated with the appropriate diagnostic code.

C. Check the ECM connector (allen head screw) for the proper torque of 6.0 N·m (55 lb in).

- D. Check the harness and wiring for abrasion and pinch points from the appropriate sensor back to the ECM.

Expected Result:

All connectors, pins and sockets should be completely coupled and/or inserted and the harness and wiring should be free of corrosion, abrasion or pinch points.

Results:

- OK – Proceed to Test Step 3.
- Not OK

Repair: Repair the connectors or wiring and/or replace the connectors or wiring. Ensure that all of the seals are properly in place and ensure that the connectors are completely coupled. Verify that the repair eliminates the problem.

STOP.

Test Step 3. Check the Coolant Level Switch

- A. Connect Cat ET to the cab data link connector.
- B. Remove the connector to the coolant level switch.
- C. Turn the ignition key switch to the ON position. Monitor the active diagnostic code screen.
- D. Short the terminals on the connector to the coolant level switch.

Expected Result:

The “Low Coolant Level Warning” code becomes inactive when the terminals are shorted.

Results:

- Yes – There is a problem with the coolant level switch.

Repair: Replace the coolant level switch.

Ensure that the repair eliminates the problem.

STOP.

- No

Repair: Reconnect the connector for the coolant level switch.

Proceed to Test Step 4.

Test Step 4. Check the Harness for the Coolant Level Switch

- A. Connect Cat ET to the cab data link connector.
- B. Insert a jumper between terminal J1:49 and terminal J1:5.
- C. Turn the ignition key switch to the ON position. Monitor the active diagnostic code screen.

Expected Result:

The “Low Coolant Level Warning” event code becomes inactive when the terminals are shorted.

Results:

- Yes – The problem is in the harness wiring.

Repair: Repair the wiring or replace the wiring, as required.

STOP.

- No – The problem is on the ECM side.

Repair: Temporarily connect a test ECM. Ensure that the parameters for “Engine Monitoring” and “Coolant Level Sensor” are programmed to match the old ECM. If the problem is resolved with the test ECM, reconnect the suspect ECM. If the problem returns with the suspect ECM, replace the ECM.

STOP.

i01597369

0111-02 Coolant Level Sensor Fault (12)

SMCS Code: 7422-038

Conditions Which Generate This Code:

This condition occurs when the coolant level sensor signals indicate a low condition and a normal condition at the same time. “Engine Monitoring” must be programmed to “WARNING”, “DERATE”, or “SHUTDOWN”, and the parameter “Coolant Level Sensor” must be programmed to “4-pin”, or “2-wire float sensor” before this diagnostic code can occur. If the parameter “Coolant Level Sensor” is programmed to “2-pin switch”, this diagnostic code is disabled.

System Response:

Electronic System Response The ECM sets the Coolant Level to OK while this diagnostic code is Active.

Service Tool Display or Lamps The Caterpillar Electronic Technician (ET) will indicate “LOW” and “DIAG” next to “Engine Coolant Level” on the status screen while the diagnostic code is active. The check engine lamp will not come on unless the diagnostic code has been continuously active for 10 hours.

Engine Response There is no effect on engine response due to this diagnostic code.

Troubleshooting:

Perform the following diagnostic procedure:
“Coolant Level Sensor Circuit - Test”

Results:

- OK – STOP.

i01724150

0111-03 Coolant Level Sensor Open Circuit (12)

SMCS Code: 1408-081; 7422-038

Conditions Which Generate This Code:

This condition occurs when there is an open in the circuit for the 2-wire float sensor. “Engine Monitoring” must be programmed to “WARNING”, “DERATE”, or “SHUTDOWN”, and the parameter “Coolant Level Sensor” must be programmed to “2-wire float sensor” before this diagnostic code can occur. If the parameter “Coolant Level Sensor” is programmed to “2-pin switch” or to “4-pin”, this diagnostic code is disabled.

System Response:

Electronic System Response The ECM sets the Coolant Level to OK while this diagnostic code is active. Coolant Level Engine Monitoring is disabled while this code is active.

Service Tool Display or Lamps The Caterpillar Caterpillar Electronic Technician (Cat ET) will indicate “OK” and “DIAG” next to “Engine Coolant Level” on the status screen while the diagnostic code is active. The check engine lamp will illuminate.

Engine Response There is no effect on engine response due to this diagnostic code.

Troubleshooting:

Perform the following diagnostic procedure:
“Coolant Level Sensor Circuit - Test”

Results:

- OK – STOP.

i01724620

0111-04 Coolant Level Sensor Short Circuit (12)

SMCS Code: 1408-081; 7422-038

Conditions Which Generate This Code:

This condition occurs when there is a short in the circuit for the 2-wire float sensor. “Engine Monitoring” must be programmed to “WARNING”, “DERATE”, or “SHUTDOWN”, and the parameter “Coolant Level Sensor” must be programmed to “2-wire float sensor” before this diagnostic code can occur. If the parameter “Coolant Level Sensor” is programmed to “2-pin switch” or to “4-pin”, this diagnostic code is disabled.

System Response:

Electronic System Response The ECM sets the Coolant Level to OK while this diagnostic code is active. Coolant Level Engine Monitoring is disabled while this code is active.

Service Tool Display or Lamps The Caterpillar Caterpillar Electronic Technician (Cat ET) will indicate “OK” and “DIAG” next to “Engine Coolant Level” on the status screen while the diagnostic code is active. The check engine lamp will illuminate.

Engine Response There is no effect on engine response due to this diagnostic code.

Troubleshooting:

Perform the following diagnostic procedure:
“Coolant Level Sensor Circuit - Test”

Results:

- OK – STOP.

i01725052

0111-11 Very Low Coolant Level (62)

SMCS Code: 7422-038

Conditions Which Generate This Code:

This condition indicates that the coolant level is very low. "Engine Monitoring" must be programmed to "WARNING", "DERATE", or "SHUTDOWN", and the parameter "Coolant Level Sensor" must be programmed to "4-pin", "2-pin switch", or "2-wire float sensor" before this diagnostic code can occur.

Note: This diagnostic code represents a critical event. This diagnostic code does not represent an electronic system fault.

System Response:

Electronic System Response If the "Engine Monitoring" is programmed to "DERATE" or "SHUTDOWN", the ECM will derate the power and the ECM will limit the vehicle speed due to this diagnostic code.

If "Engine Monitoring" is programmed to "WARNING", the Check Engine Lamp will flash and the Warning Lamp will illuminate continuously.

If "Engine Monitoring" is programmed to "DERATE" or "SHUTDOWN", the Check Engine Lamp and the Warning Lamp will flash.

This diagnostic code requires a Customer Password in order to be cleared.

Service Tool Display or Lamps Caterpillar Electronic Technician (Cat ET) will display "LOW" and "DIAG" next to "Engine Coolant Level" on the status screen while the diagnostic code is active.

Engine Response If "Engine Monitoring" is programmed to "WARNING" this diagnostic code does not affect engine power.

If "Engine Monitoring" is programmed to "DERATE" or "SHUTDOWN", the vehicle speed is limited to a maximum of 72 km/h (45 mph), and the power is limited. The engine will shut down if conditions exist for a long enough period in the SHUTDOWN mode.

Troubleshooting:

If the vehicle is equipped with the 2-Pin Switch, proceed with the following steps.

2-Pin Switch

GMT-560 applications have the option of using a 2-pin switch to monitor coolant level. To use a 2-pin switch, the parameter "Manufacturer/Model" must be programmed to "GMT-560" and the parameter "Coolant Level Sensor" must be programmed to "2-pin switch". The diagnostic fault codes for the coolant level sensors are disabled when the "Coolant Level Sensor" parameter is programmed to "2-pin switch". The switch is connected to P1/J1:49 (coolant level switch) and to P1/J1:5 (AP sensor/switch sensor common). If the coolant level is normal, the switch should be closed and P1/J1:49 connected to ground. The warning lamp will be illuminated via the J1939 data link when the coolant is low.

Test Step 1. Check the Level of the Coolant

Visually check the level of the coolant. Ensure that the coolant level switch is fully immersed in the coolant.

Expected Result:

The coolant is at the proper level.

Results:

- OK – Proceed to Test Step 2.
- Not OK

Repair: Fill the cooling system with the proper coolant to the correct level. For further information, refer to the Operations and Maintenance Manual.

STOP.

Test Step 2. Inspect Electrical Connectors and Wiring

A. Thoroughly inspect the following connectors:

- J1/P1 ECM vehicle harness connector
- Harness for the connector to the coolant level switch
- Connector terminals for the switch

Refer to Troubleshooting, "Electrical Connectors - Inspect" for details.

B. Perform a 45 N (10 lb) pull test on each of the wires in the ECM connector that are associated with the appropriate diagnostic code.

C. Check the ECM connector (allen head screw) for the proper torque of 6.0 N·m (55 lb in).

- D.** Check the harness and wiring for abrasion and pinch points from the appropriate sensor back to the ECM.

Expected Result:

All connectors, pins and sockets should be completely coupled and/or inserted and the harness and wiring should be free of corrosion, abrasion or pinch points.

Results:

- **OK** – Proceed to Test Step 3.
- **Not OK** – Repair the connectors or wiring and/or replace the connectors or wiring. Ensure that all of the seals are properly in place and ensure that the connectors are completely coupled. Verify that the repair eliminates the problem. **STOP.**

Test Step 3. Check the Coolant Level Switch

- A.** Connect Cat ET to the cab data link connector.
- B.** Remove the connector to the coolant level switch.
- C.** Turn the ignition key switch to the ON position. Monitor the active diagnostic code screen.
- D.** Short the terminals on the connector to the coolant level switch.

Expected Result:

The “Low Coolant Level Warning” code becomes inactive when the terminals are shorted.

Results:

- **Yes** – There is a problem with the coolant level switch.

Repair: Replace the coolant level switch.

Ensure that the repair eliminates the problem.

STOP.

- **No**

Repair: Reconnect the connector for the coolant level switch.

Proceed to Test Step 4.

Test Step 4. Check the Harness for the Coolant Level Switch

- A.** Connect Cat ET to the cab data link connector.

- B.** Insert a jumper between terminal J1:49 and terminal J1:5.

- C.** Turn the ignition key switch to the ON position. Monitor the active diagnostic code screen.

Expected Result:

The “Low Coolant Level Warning” event code becomes inactive when the terminals are shorted.

Results:

- **Yes** – The problem is in the harness wiring.

Repair: Repair the wiring or replace the wiring, as required.

STOP.

- **No** – The problem is on the ECM side.

Repair: Temporarily connect a test ECM. Ensure that the parameters for “Engine Monitoring” and “Coolant Level Sensor” are programmed to match the old ECM. If the problem is resolved with the test ECM, reconnect the suspect ECM. If the problem returns with the suspect ECM, replace the ECM.

STOP.

i01616892

0128-03 Secondary Fuel Level Sensor Open Circuit (44)

SMCS Code: 1408-081; 7483-038-NS

Conditions Which Generate This Code:

This diagnostic code is used only by GMT-560 applications.

The Secondary Fuel Level signal voltage is above the acceptable range for more than 10 seconds.

System Response:

Electronic System Response If the parameter “Primary Fuel Tank Size” is programmed and a diagnostic code for the primary fuel level sensor is not active, the ECM will use the primary fuel level sensor to determine the fuel level.

If the parameter "Primary Fuel Tank Size" is not programmed and a diagnostic code is active for the primary fuel level sensor, the ECM will broadcast an error code over the J1939 data link. The ECM will also broadcast the fuel level as 0 over the ATA data link.

i01765720

Service Tool Display or Lamps The Caterpillar Electronic Technician (ET) will display "DIAG" next to "Secondary Fuel Level" on the status screen while the diagnostic code is active.

Perform the following diagnostic procedure: "Fuel Level Sensor Circuit - Test"

Results:

- OK – STOP.

i01616895

0128-04 Secondary Fuel Level Sensor Short Circuit (44)

SMCS Code: 1408-081; 7483-038-NS

Conditions Which Generate This Code:

This diagnostic code is used only by GMT-560 applications.

The Secondary Fuel Level signal voltage is below the acceptable range for more than 10 seconds.

System Response:

Electronic System Response If the parameter "Primary Fuel Tank Size" is programmed and a diagnostic code for the primary fuel level sensor is not active, the ECM will use the primary fuel level sensor to determine the fuel level.

If the parameter "Primary Fuel Tank Size" is not programmed and a diagnostic code is active for the primary fuel level sensor, the ECM will broadcast an error code over the J1939 data link. The ECM will also broadcast the fuel level as 0 over the ATA data link.

Service Tool Display or Lamps The Caterpillar Electronic Technician (ET) will display "DIAG" next to "Secondary Fuel Level" on the status screen while the diagnostic code is active.

Perform the following diagnostic procedure: "Fuel Level Sensor Circuit - Test"

Results:

- OK – STOP.

0164-00 Injection Actuation Pr Out of Range (17)

SMCS Code: 1925-038

Conditions Which Generate This Code:

The ECM detected all of the following conditions:

- The ECM has been powered for at least three seconds.
- The diagnostic fault codes for the +5 V sensor supply are not active.
- The diagnostic fault codes for the injection actuation pressure sensor are not active.
- Cold Mode is not active.
- The injection actuation pressure is greater than 26.5 MPa (3844 psi) for 6 seconds.

Note: The diagnostic code indicates a mechanical problem. The ECM and the electronic control system is operating correctly.

System Response:

Electronic System Response The ECM limits power output to 89.5 kW (120.0 hp) and the vehicle speed is limited to 73 km/h (45 mph).

Service Tool Display or Lamps Caterpillar Electronic Technician (Cat ET) will display "0%" next to "Injector Output %" on the status screen while the diagnostic code is active. The check engine lamp will illuminate.

Engine Response The engine will be low on power and the vehicle speed will be limited.

Note: The problem may only exist at operating temperature.

Troubleshooting:

Perform the following diagnostic procedure: "Injection Actuation Pressure - Test"

Results:

- OK – STOP.

i01725081

0164-02 Injection Actuation Pressure Sensor Erratic (15)

SMCS Code: 1925-038

Conditions Which Generate This Code:

The ECM detected one of the following conditions:

- Injection actuation pressure with the engine shutdown
- The actual pressure and the desired pressure are substantially different.
- The change in injection actuation pressure was not consistent with the change in sensor current.

System Response:

Electronic System Response The ECM will indicate an active code and the code will be logged.

Service Tool Display or Lamps Caterpillar Electronic Technician (Cat ET) will display 17.5 MPa (2538 psi) next to “Desired Injection Actuation Pressure” and “Actual Injection Actuation Pressure” on the status screen while the diagnostic code is active. The Check Engine Lamp will illuminate.

Engine Response This code can occur with the engine off.

Troubleshooting:

Perform the following diagnostic procedure: “Injection Actuation Pressure Sensor - Test”

Results:

- OK – STOP.

i01638879

0164-03 Injection Actuation Pressure Sensor Open Circuit (15)

SMCS Code: 1408-081; 1925-038

Conditions Which Generate This Code:

The voltage in the injection actuation pressure circuit is higher than normal.

System Response:

Electronic System Response The ECM will assume that the injection actuation pressure is 17.5 MPa (2538 psi). The control valve for the “Injection Actuation Pressure System” is set to a fixed position. The fuel delivery is limited.

Service Tool Display or Lamps Caterpillar Electronic Technician (ET) will display 17.5 MPa (2538 psi) next to “Desired Injection Actuation Pressure” and “Actual Injection Actuation Pressure” on the status screen while the diagnostic code is active. The Check Engine Lamp will illuminate.

Engine Response The engine will run rough at idle. Power output will be below normal and the vehicle speed will be limited to 72 km/h (45 mph).

Troubleshooting:

Perform the following diagnostic procedure: “Engine Pressure Sensor Open or Short Circuit - Test”

Results:

- OK – STOP.

i01638880

0164-04 Injection Actuation Pressure Sensor Short Circuit (15)

SMCS Code: 1408-081; 1925-038

Conditions Which Generate This Code:

The voltage in the injection actuation pressure circuit is below normal.

System Response:

Electronic System Response The ECM will assume that the injection actuation pressure is 17.5 MPa (2538 psi). The control valve for the “Injection Actuation Pressure System” is set to a fixed position. The fuel delivery is limited.

Service Tool Display or Lamps Caterpillar Electronic Technician (ET) will display 17.5 MPa (2538 psi) next to “Desired Injection Actuation Pressure” and “Actual Injection Actuation Pressure” on the status screen while the diagnostic code is active. The Check Engine Lamp will illuminate.

Engine Response The engine will run rough at idle. Power output will be below normal and the vehicle speed will be limited to 72 km/h (45 mph).

Troubleshooting:

Perform the following diagnostic procedure: "Engine Pressure Sensor Open or Short Circuit - Test"

Results:

- OK – STOP.

i01728916

0164-11 Injection Actuation Pressure System (39)

SMCS Code: 1714-038; 5051-038

Conditions Which Generate This Code:

The ECM detected one of the following conditions:

- The actual pressure and the desired pressure are substantially different.
- The "Injection Actuation Pressure Control Valve Driver" was at the maximum output or the minimum output for a longer time than needed.

Note: The diagnostic code indicates a mechanical problem. The ECM and the electronic control system are operating correctly.

System Response:

Engine Response The engine may be low on power and the idle may be unstable. The engine may be difficult to start at normal operating temperatures, but the engine may start easily when the engine is cold.

Note: The problem may only exist at operating temperature. Air may be trapped in the injection actuation system if the system has been serviced recently. Start the engine and run the engine at 1500 rpm for a few minutes in order to remove the trapped air.

Troubleshooting:

Perform the following diagnostic procedure: "Injection Actuation Pressure - Test"

Results:

- OK – STOP.

i01643962

0168-02 Intermittent Battery (51)

SMCS Code: 1408-081

Conditions Which Generate This Code:

This condition indicates that the battery circuit to the ECM has a battery condition that is intermittent or a battery condition that is low while the engine is running. If battery voltage disappears without returning, the ECM will not log this diagnostic code and the engine will shut down.

System Response:

Electronic System Response The ECM may stop injecting fuel. This may be dependent on the length of time of the occurrence of the fault.

Engine Response The engine may experience changes in the engine rpm, and intermittent engine shutdowns or complete engine shutdowns while the conditions that cause this diagnostic code are present.

Service Tool Display or Lamps The Check Engine Lamp and the Warning Lamp may come on as if the ignition key switch was just turned on and the engine started.

Troubleshooting:

Perform the following diagnostic procedure: "Ignition Key Switch Circuit and Battery Supply Circuit - Test"

Results:

- OK – STOP.

i01617077

0186-04 PTO Engine Shutdown Short Circuit

SMCS Code: 1165-038-ZS; 1408-081

Conditions Which Generate This Code:

A short to ground exists in the wiring for the PTO Engine Shutdown Switch. The parameter "PTO Engine Shutdown Switch" must be programmed to "J1/P1:7" or "J1/P1:23".

System Response:

Electronic System Response The ECM will not allow the PTO to engage while this fault is active.

Service Tool Display or Lamps The Caterpillar Electronic Technician (ET) will display “DIAG” on the status screen while the diagnostic code is active.

Perform the following diagnostic procedure: “PTO Engine Shutdown Switch Circuit - Test”

Results:

- OK – STOP.

i01617310

0186-14 PTO Shutdown Switch Occurrence (47)

SMCS Code: 1165-038-ZS; 1408-081

Conditions Which Generate This Code:

All of the following conditions must be met.

- The parameter “PTO Configuraton” is programmed to “Cab Switches”, “Remote Switches”, or “Remote Throttle”.
- The PTO switch is on the ON position.
- The parameter “PTO Engine Shutdown Switch” is programmed to “J1/P1:7” or “J1/P1:23”.
- The PTO Engine Shutdown Switch is off and the PTO switch is active for 0.5 seconds.
- The PTO Engine Shutdown Switch changes state for 0.5 seconds.

System Response:

Electronic System Response The engine will shut down and PTO mode will be deactivated. The ECM will not allow the PTO to engage while this fault is active.

Service Tool Display or Lamps The Caterpillar Electronic Technician (ET) will not display a status.

Perform the following diagnostic procedure: “PTO Engine Shutdown Switch Circuit - Test”

Results:

- OK – STOP.

i01640819

0190-00 Engine Overspeed Warning (35)

SMCS Code: 1907-038

Conditions Which Generate This Code:

This condition indicates that the engine speed has exceeded 3300 rpm.

System Response:

Electronic System Response The ECM shuts off the fuel injection delivery above the programmed “Top Engine Limit” (TEL).

This diagnostic code requires a Factory Password in order to be cleared.

This diagnostic code represents a critical event. This diagnostic code does not represent an electronic system fault.

Service Tool Display or Lamps Caterpillar Electronic Technician (ET) will display “TOP ENGINE LIMIT” in a unique area of the status screen when the engine rpm has reached the top engine limit or when the engine rpm has exceeded the top engine limit. The Check Engine Lamp will illuminate.

Troubleshooting:

There are no problems that require troubleshooting.

This diagnostic code indicates an excessive engine speed. This diagnostic code does not indicate a problem with the ECM or the engine speed/timing sensor.

Results:

- OK – STOP.

i01640960

0190-02 Loss of Engine RPM Signal (34)

SMCS Code: 1408-081; 1907-038

Conditions Which Generate This Code:

The signal for the camshaft position sensor 1 (top) is intermittent or lost.

i01641096

System Response:

Electronic System Response The check engine lamp will not be illuminated for this code unless the code has been active for 10 hours. The code is logged.

Service Tool Display or Lamps Caterpillar Electronic Technician (ET) will not display a status.

Engine Response There should not be a noticeable change in engine response unless the signal for the camshaft position sensor 2 (bottom) is lost. This loss will shut down the engine.

Troubleshooting:

Perform the following diagnostic procedure: "Engine Speed/Timing Sensor Circuit - Test"

Results:

- OK – STOP.

i01640983

0190-11 No Pattern on Speed Sensor #1 (34)

SMCS Code: 1408-081; 1907-038

Conditions Which Generate This Code:

The signal for the camshaft position sensor 1 (top) is lost.

System Response:

Electronic System Response The check engine lamp will not be illuminated for this code unless the code has been active for 10 hours. The code is logged.

Service Tool Display or Lamps Caterpillar Electronic Technician (ET) will not display a status.

Engine Response There should not be a noticeable change in engine response unless the signal for the camshaft position sensor 2 (bottom) is lost. This loss will shut down the engine.

Troubleshooting:

Perform the following diagnostic procedure: "Engine Speed/Timing Sensor Circuit - Test"

Results:

- OK – STOP.

0224-11 Theft Deterrent Active (00)

SMCS Code: 1900

Conditions Which Generate This Code:

The theft deterrent feature has been enabled. The correct password must be entered in order to disable the theft deterrent. Then, the engine can be started.

Note: This diagnostic code represents an event. This diagnostic code does not represent an electronic system fault.

The ECM will operate in the "Secure Idle" mode if the theft deterrent password is entered. The engine must be running in order to operate in the "Secure Idle" mode. The ECM will be in the "Secure Idle" mode until the theft deterrent password is entered again.

System Response:

Electronic System Response The diagnostic code is active only. The diagnostic code will be active when the theft deterrent feature is enabled.

Service Tool Display and Lamps Caterpillar Electronic Technician (ET) will not display a status. The Check Engine Lamp will be illuminated.

Engine Response The engine will not start until the correct password is entered. The engine will be limited to the Low Idle rpm if the "Secure Idle" mode is active.

Troubleshooting:

This diagnostic code indicates that the theft deterrent feature has been enabled. There is no electronic system fault.

No Troubleshooting is required.

Results:

- OK – STOP.

i01641127

0224-14 Engine Cranking with Theft Deterrent Active (00)

SMCS Code: 1900; 1901

Conditions Which Generate This Code:

The diagnostic code indicates that an attempt is being made in order to start the engine. However, the theft deterrent feature is enabled. This prevents the engine from being started.

Note: This diagnostic code represents an event. This diagnostic code does not represent an electronic system fault.

System Response:

Electronic System Response The diagnostic code is active only. The diagnostic code will be active when the theft deterrent feature is enabled and the engine is cranking for more than 5 seconds.

Service Tool Display and Lamps Caterpillar Electronic Technician (ET) will not display a status. The Check Engine Lamp will be illuminated.

Engine Response The engine will not start until the correct password is entered.

Troubleshooting:

The diagnostic code indicates that an attempt is being made in order to start the engine. However, the theft deterrent feature is enabled. This diagnostic code does not represent an electronic system fault.

There are no problems that require troubleshooting.

Results:

- OK – STOP.

i01815528

0231-02 J1939 Required Data Not Received (58)

SMCS Code: 1901-038

Conditions Which Generate This Code:

This condition indicates that the J1939 data link is receiving information from a specified device but the information is incomplete or corrupted. All of the following conditions must be met:

- The parameter “Powertrain Data Link” must be programmed to J1939.
- The ECM is unsuccessful in receiving a specific message from a device.

or

- The device is broadcasting a fault code.

or

- The device is broadcasting a code that is not supported.

System Response:

Electronic System Response J1939 communications to the engine and from the engine are terminated for the specific message while this code is active. The functionality of some features may be affected while this code is active. Traction control or transmission controls may be disabled.

Service Tool Display or Lamps The Caterpillar Electronic Technician (ET) will indicate a safe default value or display “DIAG” on a status screen. If the device sends a message that is not supported, the service tool will display “J1939 No Support”. ET will display a list of the devices that are causing this code on the “Active Faults” screen. If the list of devices that are causing this code is too large, all of the devices will not be listed until some of the incorrect messages are corrected.

Perform the following diagnostic procedure: “Powertrain Data Link Circuit - Test”

Results:

- OK – STOP.

i01617519

0231-11 J1939 Data Link Fault (58)

SMCS Code: 1408-038; 1901-038

Conditions Which Generate This Code:

This condition indicates that the SAE J1939 data link is not communicating correctly. The parameter “Powertrain Data Link” must be programmed to J1939.

System Response:

Electronic System Response Communications with other control modules that use the J1939 data link may be interrupted while this diagnostic code is active.

Note: If the vehicle is not using the J1939 data link, program "Powertrain Data Link" to "None". After the "Powertrain Data Link" is programmed correctly this active diagnostic code should deactivate.

Troubleshooting:

Contact the OEM dealer in order to determine if the vehicle was configured for the J1939 data link. If the vehicle is not using the J1939 data link, program "Powertrain Data Link" to "None". This will correct the problem.

If the vehicle is using the J1939 data link, proceed with the following procedure:

Perform the following diagnostic procedure:
"Powertrain Data Link Circuit - Test"

Results:

- OK – STOP.

i01617802

0231-12 J1939 Device Not Responding

SMCS Code: 1901-038

Conditions Which Generate This Code:

This condition indicates that the J1939 data link has a short circuit or an open circuit. All of the following conditions must be met:

- The parameter "Powertrain Data Link" must be programmed J1939.
- The ECM is unsuccessful in receiving a response to a message that has been transmitted for 10 seconds.

Electronic System Response J1939 communications to the engine and from the engine are terminated while this code is active. The functionality of some features may be affected while this code is active. Traction control or transmission controls may be disabled.

Service Tool Display or Lamps The Caterpillar Electronic Technician (ET) will display "NO COMM" on the status screen next to the inputs that are not receiving communications.

Perform the following diagnostic procedure:
"Powertrain Data Link Circuit - Test"

Results:

- OK – STOP.

i01641146

0232-03 5 Volt Supply Above Normal (21)

SMCS Code: 1408-081; 1900-038; 1901-038

Conditions Which Generate This Code:

The supply voltage for the pressure sensors of the engine is exceeding a level that is normal.

System Response:

Electronic System Response All pressure sensors of the engine are set to default values. All diagnostic codes for the pressure sensors of the engine are disabled while this diagnostic code is active.

Service Tool Display or Lamps Caterpillar Electronic Technician (ET) will display the default status of the sensors. This default status is indicated in the following list:

- Boost pressure 0 kPa (0 psi)
- Engine Oil Pressure 600 kPa (87 psi)
- Atmospheric Pressure 100 kPa (15 psi)
- Injection Actuation Pressure 17.5 kPa (2.53 psi)
- Injection Actuation Driver Current 40%

ET will also display "DIAG" next to the status of the sensor in order to indicate that the sensor is operating at the value that is shown due to an active diagnostic code.

Engine Response An active diagnostic code may not cause any noticeable effect on engine response. However, the active diagnostic code may cause the engine to have the following effects:

- Run rough.
- Low power

These effects are dependent on the operating conditions that exist at the time when the code occurs.

Troubleshooting:

Perform the following diagnostic procedure: "5 Volt Engine Pressure Sensor Supply Circuit - Test"

Results:

- OK – STOP.

i01641176

0232-04 5 Volt Supply Below Normal (21)

SMCS Code: 1408-081; 1900-038; 1901-038

Conditions Which Generate This Code:

The supply voltage for the pressure sensors of the engine is below normal level.

System Response:

Electronic System Response All pressure sensors of the engine are set to default values. All diagnostic codes for the pressure sensors of the engine are disabled while this diagnostic code is active.

Service Tool Display or Lamps Caterpillar Electronic Technician (ET) will display the default status of the sensors. This default status is indicated in the following list:

- Boost pressure 0 kPa (0 psi)
- Engine Oil Pressure 600 kPa (87 psi)
- Atmospheric Pressure 100 kPa (15 psi)
- Injection Actuation Pressure 17.5 kPa (2.50 psi)
- Injection Actuation Driver Current 40%

ET will display "DIAG" next to the status of the sensor in order to indicate that the sensor is operating at the value that is shown due to an active diagnostic code.

Engine Response An active diagnostic code may not cause any noticeable effect on engine response. However, the active diagnostic code may cause the engine to have the following effects:

- Run rough.
- Low power

These effects are dependent on the operating conditions that exist at the time when the code occurs.

Troubleshooting:

Perform the following diagnostic procedure: "5 Volt Engine Pressure Sensor Supply Circuit - Test"

Results:

- OK – STOP.

i01745196

0246-11 Brake Switch #1

SMCS Code: 1129-ZS

Conditions Which Generate This Code:

The engine is running and both of the following conditions exist:

- The status of the service brake pedal position switch 1 indicates that the brake pedal has been depressed.
- The status of the service brake pedal position switch 2 indicates that the pedal has been released.

System Response:

Electronic System Response The diagnostic code is logged into memory only if the engine is running. This diagnostic code will prevent cruise control, PTO operation, or idle operation. The check engine lamp will not illuminate for this diagnostic code.

Engine Response The engine will disengage or the engine will not allow the setting of the cruise control, the PTO, or the idle speed.

Troubleshooting:

Perform the following diagnostic procedure: "Service Brake Pedal Position (Switch 1) Circuit -Test"

Results:

- OK – STOP.

i01745419

0247-11 Brake Switch #2

SMCS Code: 1129-ZS

Conditions Which Generate This Code:

The engine is running and both of the following conditions exist:

- The status of the service brake pedal position switch 2 indicates that the brake pedal has been depressed.
- The status of the service brake pedal position switch 1 indicates that the pedal has been released.

System Response:

Electronic System Response The diagnostic code is logged into memory only if the engine is running. This diagnostic code will prevent cruise control, PTO operation, or idle operation. The check engine lamp will not illuminate for this diagnostic code.

Engine Response The engine will disengage or the engine will not allow setting of the cruise control, the PTO, or the idle speed.

Troubleshooting:

Perform the following diagnostic procedure: "Service Brake Pedal Position (Switch 2) Circuit - Test"

Results:

- OK – STOP.

i01641223

0252-11 Incorrect Engine Software (59)

SMCS Code: 1902-535; 7620-535

Conditions Which Generate This Code:

This condition occurs when the Personality Module is changed and the new module that is installed is for a different engine.

System Response:

Electronic System Response The ECM will not allow the engine to start.

Service Tool Display or Lamps The Check Engine Lamp will illuminate.

Engine Response The engine will not start.

Troubleshooting:

Perform the following diagnostic procedure: "ECM Memory - Test"

Results:

- OK – STOP.

i01641234

0253-02 Check Customer or System Parameters (56)

SMCS Code: 1901-535

Conditions Which Generate This Code:

This condition indicates a "Customer Specified Parameter" or a system configuration parameter that requires programming has not been programmed. Once this parameter has been programmed, the code may still be active. This can happen if there is yet another parameter that requires programming.

System Response:

Electronic System Response The fault is active only and the fault is not logged. If the Personality Module Code of the new personality module does not match the code of the old personality module, the engine is limited to low idle. If the "Rating Number" has not been programmed, the ECM limits the engine to 89.5 kW (120.0 hp). When a new ECM is initially powered up, the following parameters must be programmed to avoid this diagnostic code:

- "Full Load Setting" (FLS)
- "Full Torque Setting" (FTS)
- "Vehicle Speed Calibration"
- "Rating Number"
- "Engine Serial Number"

Service Tool Display or Lamps Caterpillar Electronic Technician (ET) will display a list of the parameters that require programming. If two or more Multi I/O parameters are programmed to the same input/output, only one of the Multi I/O parameters will be listed at one time. If the list of parameters exceeds the limit, the Multi I/O parameters will not be listed until some of the other parameters are corrected. This will make space on the list in order to display the Multi I/O parameters. The Check Engine Lamp will illuminate.

Engine Response The ECM will limit the engine to low idle if the parameter is the FLS or the FTS. The ECM may also limit the power if the parameter is a rating number.

Troubleshooting:

Perform the following diagnostic procedure: "ECM Memory - Test"

Results:

- OK – STOP.

i01643984

0253-14 Truck Manufacturer Parameter Not Programed

SMCS Code: 1901-535

Conditions Which Generate This Code:

The "Truck Manufacturer Parameter" has not been programmed. The parameter must be programmed for the manufacturer of the chassis in order to configure the correct options and ranges for the engine.

Note: The "Truck Manufacturer Parameter" must be programmed before the "Customer Parameters" are programmed.

System Response:

Electronic System Response The code is active, but the code is not logged. The check engine lamp will be on when the code is active.

Engine Response The ECM will select the GM parameter as the default until the appropriate parameter is programmed.

Troubleshooting:

Perform the following diagnostic procedure: "ECM Memory - Test"

Results:

- OK – STOP.

Diagnostic Functional Tests

i01631722

5 Volt Engine Pressure Sensor Supply Circuit - Test

SMCS Code: 1408-081; 1901-081

System Operation Description:

Use this procedure under the following situation:

Use this procedure to troubleshoot the system when one of the following diagnostic codes is active or easily repeated:

- 232-03 5 Volt Supply Above Normal (21)
- 232-04 5 Volt Supply Below Normal (21)

Also, use this procedure to troubleshoot the system when you have been directed here by another troubleshooting procedure.

The following background information is related to this procedure:

The Engine Control Module (ECM) supplies the following sensors with regulated +5 V DC power from the same supply:

- J200/P200 boost pressure sensor
- J203/P203 atmospheric pressure sensor (specific ratings only)
- J201/P201 engine oil pressure sensor (optional)
- J204/P204 injection actuation pressure sensor

The supply for the +5 V engine pressure sensor is routed from the ECM through ECM engine harness connector J2/P2 terminal 2 to terminal "A" of each pressure sensor connector. The supply voltage is 5.0 ± 0.5 V DC.

The +5 V diagnostic code is probably caused by a short circuit or an open circuit in the harness. The next probable cause is a sensor and the least probable cause is the ECM.

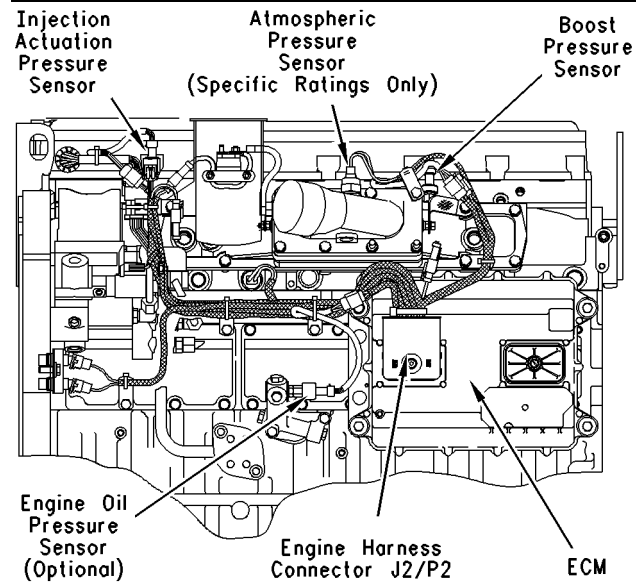

Illustration 20

g00767035

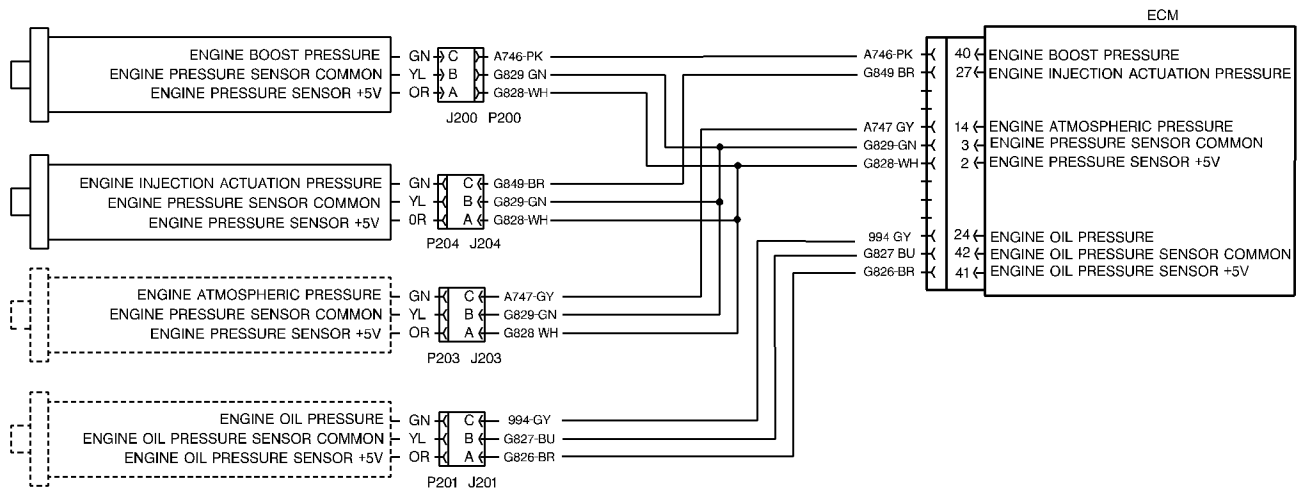

Illustration 21

g00767119

Schematic of the +5 V supply for the engine pressure sensor

Test Step 1. Inspect Electrical Connectors and Wiring.

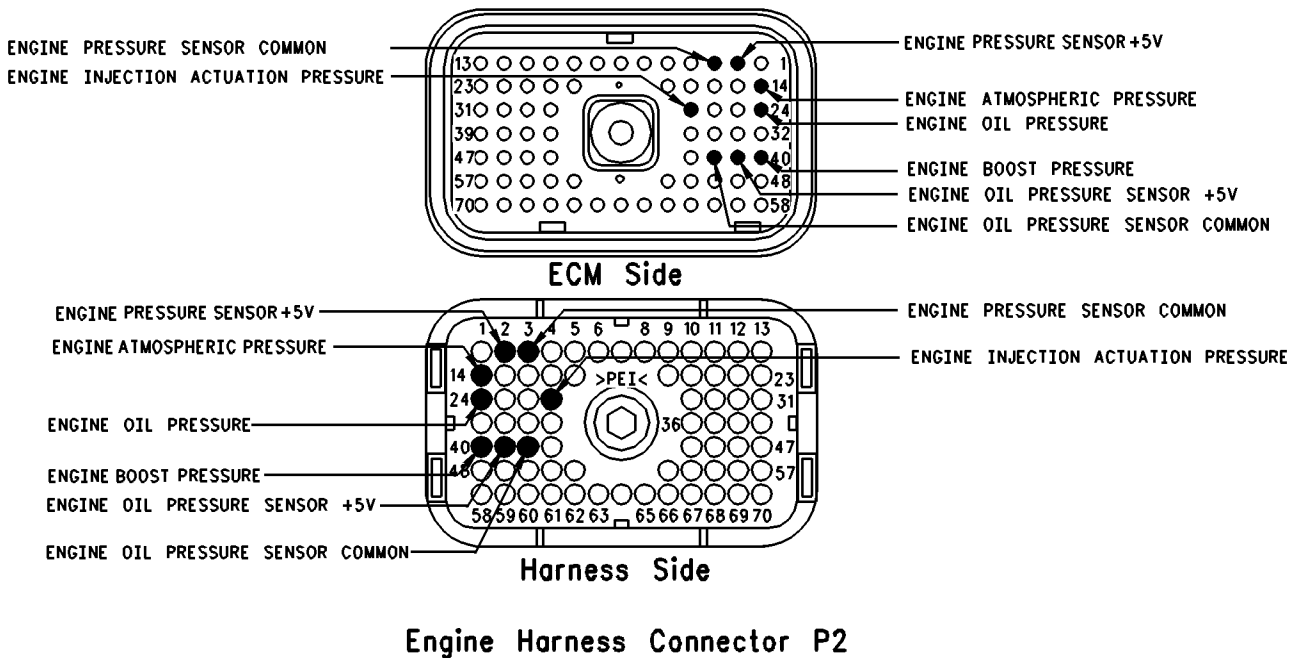

Illustration 22

g00723875

Terminal locations for ECM

- A.** Thoroughly inspect ECM engine harness connector J2/P2, boost pressure sensor J200/P200, engine oil pressure sensor J201/P201, atmospheric pressure sensor J203/P203 and Injection actuation pressure sensor J204/P204. Refer to Troubleshooting, “Electrical Connectors - Inspect” for details.
- B.** Perform a 45 N (10 lb) pull test on each of the wires in the ECM connector that are associated with the +5 V engine pressure sensor supply:
- +5 V engine pressure sensor terminal 2 (G828-WH)
 - engine pressure sensor common terminal 3 (G829-GN)
- Refer to Illustration 22.
- C.** Check the ECM connector (allen head screw) for the proper torque of 6.0 N·m (55 lb in).
- D.** Check the harness and wiring for abrasion and pinch points from the sensors back to the ECM.

Expected Result:

All connectors, pins and sockets should be completely coupled and/or inserted and the harness and wiring should be free of corrosion, abrasion or pinch points.

Results:

- **OK** – Proceed to Test Step 2.
- **Not OK**

Repair: Perform the following repair:

Repair the connectors or wiring and/or replace the connectors or wiring. Ensure that all of the seals are properly in place and ensure that the connectors are completely coupled.

Verify that the repair eliminates the problem.

STOP.

Test Step 2. Connect ET and Check for Active Diagnostic Codes.

- A.** Connect Caterpillar Electronic Technician (ET) to the cab data link connector.
- B.** Turn the ignition key switch to the ON position.
- C.** Monitor the “Active Diagnostic Code” screen of ET. Check and record active diagnostic codes.

Note: Wait at least 15 seconds in order for the diagnostic codes to become active.

Expected Result:

Select the condition of the following codes:

- 232-03 5 Volt Supply Above Normal (21)
- 232-04 5 Volt Supply Below Normal (21)

Results:

- **Active** – Proceed to Test Step 3.
- **Logged ONLY** – Proceed to Test Step 5.
- **Not active or logged** – The +5 V supply is operating correctly at this time. **STOP.**

Test Step 3. Disconnect the ECM Engine Harness Connector from the ECM.

- A.** Connect ET to the cab data link connector.
- B.** Turn the ignition key switch to the OFF position.
- C.** Disconnect ECM engine harness connector J2/P2.
- D.** Turn the ignition key switch to the ON position.
- E.** Access the “Active Diagnostic Code” screen on ET. Check for one of the following active diagnostic codes:
- 232-03 5 Volt Supply Above Normal (21)
 - 232-04 5 Volt Supply Below Normal (21)

Note: When ECM engine harness connector J2/P2 is disconnected and the ignition key switch is in the ON position, open circuit diagnostic codes will be active or logged for all of the engine sensors. This is normal. The codes for the 5 Volt supply should not be active.

Expected Result:

The +5 V diagnostic code is active when the ECM engine harness connector is disconnected.

Results:

- **Yes** – Disconnecting the engine harness does not eliminate the active +5 V sensor diagnostic code.

Repair: Perform the following diagnostic procedure:

1. Temporarily connect a test ECM. Only connect ECM harness J1/P1.
2. Recheck for an +5 V diagnostic code when the engine harness is disconnected.

3. If the problem is resolved with the test ECM, reconnect the suspect ECM.
4. If the problem returns with the suspect ECM, replace the ECM.

STOP.

- **No** – The +5 V diagnostic code is no longer active when the harness is disconnected. Either the harness or a sensor that is attached to the harness is causing the problem. Reconnect the ECM engine harness connector. Proceed to Test Step 4.

Test Step 4. Disconnect the +5 V Sensors While Active Diagnostic Codes are Being Monitored.

- A.** Connect ET to the cab data link connector.
- B.** Turn the ignition key switch to the ON position.
- C.** Access the “Active Diagnostic Code” screen on ET. Verify that one of the following diagnostic codes is active:
 - 232-03 5 Volt Supply Above Normal (21)
 - 232-04 5 Volt Supply Below Normal (21)
- D.** Disconnect the following sensors one at a time:
 - Boost pressure sensor J200/P200
 - Injection actuation pressure sensor J204/P204
 - Engine oil pressure sensor J201/P201
 - Atmospheric pressure sensor J203/P203
- E.** Wait for 30 seconds after each pressure sensor is disconnected while ET is being monitored in order to verify that the disconnection of a specific sensor deactivates the +5 V diagnostic code.

Note: When the sensors are disconnected and the ignition key switch is in the ON position, open circuit diagnostic codes will be active or logged when the +5 V diagnostic codes are no longer active. This is normal. Clear these diagnostic codes after this test step is completed.

Expected Result:

The original +5 V diagnostic code remains active.

Results:

- **Yes** – The +5 V diagnostic code is still active. The harness is the cause of the problem. Leave the sensors disconnected. Proceed to Test Step 5.
- **No** – Disconnecting a specific sensor makes the +5 V diagnostic code no longer active.

Repair: Perform the following diagnostic procedure:

1. Reconnect the sensor that is suspected of causing the problem.
2. If the problem returns after the reconnection of the sensor, disconnect the sensor.
3. If the problem disappears after the disconnection of the sensor, replace the sensor.
4. Clear all diagnostic codes.
5. Verify that the repair eliminates the problem.

STOP.

Test Step 5. Check the Engine Harness.

Illustration 23

g00724122

Engine harness connector P2

- A.** Turn the ignition key switch to the OFF position.
- B.** Disconnect ECM engine harness connector J2/P2. Verify that all of the +5 V engine pressure sensors that are attached to the ECM engine harness connector are disconnected.
- Boost pressure sensor J200/P200
 - Engine oil pressure sensor J201/P201
 - Atmospheric pressure sensor J203/P203
 - Injection actuation pressure sensor J204/P204
- C.** Set a multimeter in order to measure the resistance on the range that is close to 20 Ohms, but not less than 20 Ohms.
- a.** Measure the resistance from the ECM engine harness connector P2 terminal 2 (+5 V engine pressure sensor) to each of the following terminals:
- P2 terminal 14 (atmospheric pressure signal)
 - P2 terminal 24 (oil pressure signal)
 - P2 terminal 27 (injection actuation pressure signal)
 - P2 terminal 40 (boost pressure signal)
 - P2 terminal 3 (engine pressure sensor common)
 - P2 terminal 65 (battery negative)

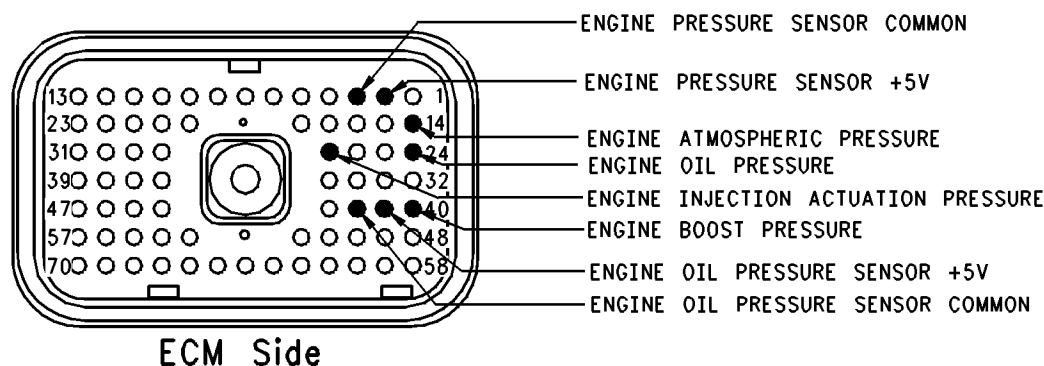
Refer to Illustration 23.

- b.** Wiggle the harness during the measurement in order to reveal any intermittent short condition.

Expected Result:

Each resistance measurement is more than 20 Ohms.

Results:

- **OK** – The +5 V line is not shorted in the engine harness. Ensure that the engine harness is connected to the ECM and that all of the sensors are reconnected. There does not appear to be a problem at this time. Clear all diagnostic codes. Continue to troubleshoot until the original condition is resolved. **STOP.**

- **Not OK** – The engine harness has a short circuit.

Repair: Perform the following repair:

1. Replace the engine harness.
2. Clear all logged diagnostic codes.
3. Verify that the repair eliminates the problem.

STOP.

i01622115

Accelerator Pedal (Throttle) Position Sensor Circuit - Test

SMCS Code: 1913-081

System Operation Description:**Use this procedure under the following situation:**

Use this procedure if any of the following diagnostic codes are indicated:

- 91-08 Invalid Throttle Signal (32)

- 91-13 Throttle Sensor Calibration (28)
- 41-03 8 Volt Supply Above Normal (21)
- 41-04 8 Volt Supply Below Normal (21)

The ECM is in PTO mode if the “PTO On/Off Switch” is on. This can be checked with the Caterpillar Electronic Technician (ET). Refer to Troubleshooting, “PTO Switch Circuit - Test” for testing if the PTO is being used.

Also, use this procedure if the accelerator pedal position sensor is suspected of improper operation.

Accelerator Pedal Position Sensor

The accelerator pedal position sensor is used to provide a throttle position signal to the ECM. Sensor output is a constant frequency signal with a pulse width that varies with the pedal position. This output signal is referred to as either a duty cycle or a pulse width modulated signal (PWM) and this output signal is expressed as a percentage between 3 and 100 percent.

The pedal mounted accelerator pedal position sensor is attached directly to the accelerator pedal assembly and the pedal mounted accelerator pedal position sensor requires no adjustment.

The accelerator pedal position sensor will produce a duty cycle of 10 to 22 percent at low idle and 75 to 90 percent when the accelerator pedal is fully depressed. The percent of duty cycle is translated in the ECM into an accelerator pedal position of 3 to 100 percent.

The accelerator pedal position sensor is powered by the ECM supply voltage (+8 VDC) from connector P1:4 to terminal “A” of the accelerator pedal position sensor connector. The accelerator pedal position sensor can be replaced separately from the pedal assembly. An incorrectly calibrated pedal assembly can not be adjusted. The entire pedal assembly must be replaced.

If the vehicle is using the ECM dedicated PTO functions, the accelerator pedal position sensor will be ignored while the engine is in PTO mode and the “PTO Configuration” is programmed to one of the following parameters:

- Remote Switches
- Remote Throttle

Note: In the cab switches configuration, the cab accelerator pedal can be used in order to control the engine rpm for the PTO operation. The cab accelerator pedal can also be ignored in the “Cab Switches” PTO configuration. Programming of customer parameters is required in order to ignore the cab accelerator pedal in the “Cab switches” configuration.

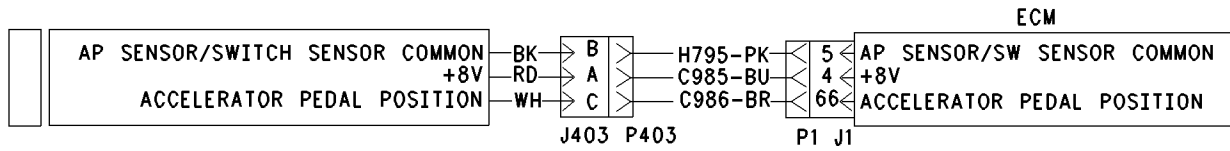

Illustration 24

g00642016

Schematic for cab accelerator pedal position sensor

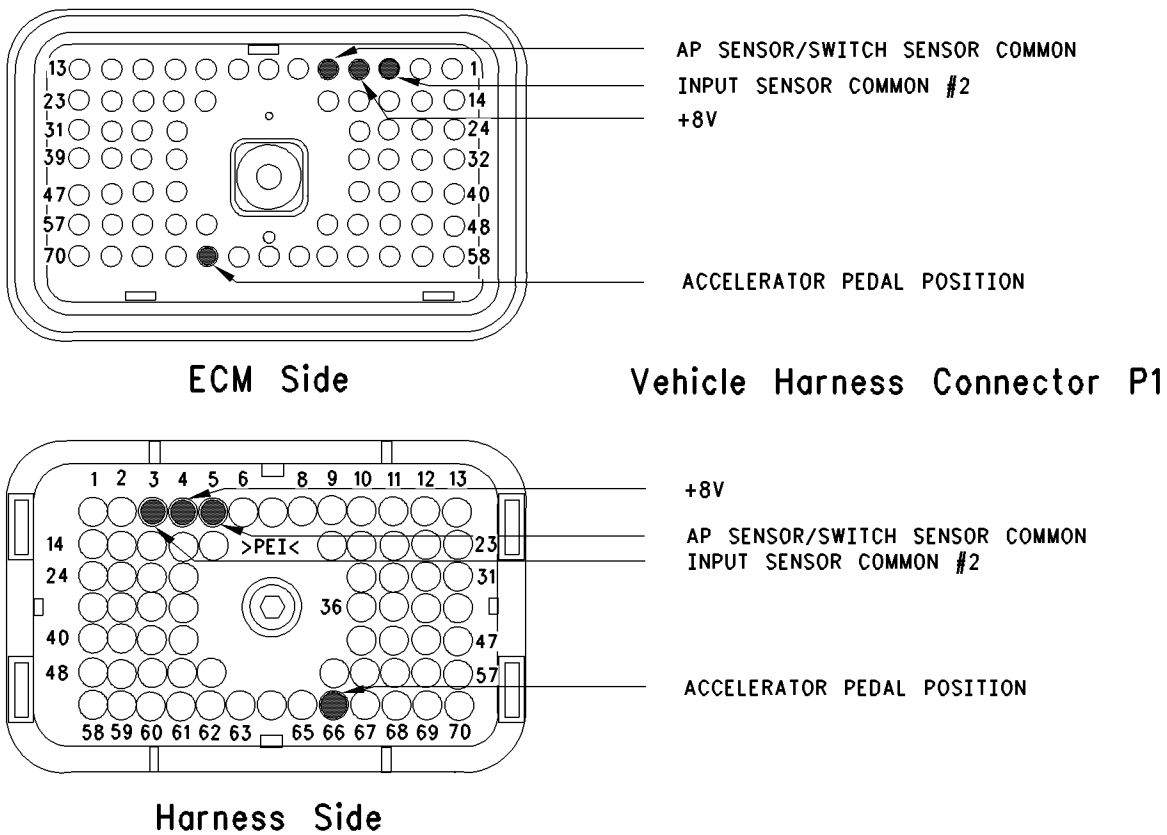

Illustration 25

g00668027

Terminal locations for ECM

Test Step 1. Inspect Electrical Connectors and Wiring

- A.** Thoroughly inspect ECM vehicle harness connector J1/P1, the firewall bulkhead connector and the accelerator pedal position sensor connector. Refer to Troubleshooting, "Electrical Connectors - Inspect" for details.
- B.** Perform a 45 N (10 lb) pull test on each of the wires in the ECM connector that are associated with the accelerator pedal position sensor:

- P1:4
- P1:5
- P1:66
- C.** Check the ECM connector (Allen Head Screw) for the proper torque of 6.0 N·m (55 lb in).
- D.** Check the harness and wiring for abrasion and pinch points from the accelerator pedal position sensor to the ECM.

- P1:3

Expected Result:

All connectors, pins and sockets should be completely coupled and/or inserted and the harness and wiring should be free of corrosion, abrasion or pinch points.

Results:

- OK – Proceed to Test Step 2.
- Not OK

Repair: Perform the following repair:

Repair the connectors or wiring and/or replace the connectors or wiring. Ensure that all of the seals are properly in place and ensure that the connectors are completely coupled.

Verify that the repair eliminates the problem.

STOP.

Test Step 2. Check for Active Diagnostic Codes

- A. Connect ET to the cab data link connector.
- B. Turn the ignition key switch to the ON position.
- C. Monitor the active diagnostic code screen on ET. Check and record active diagnostic codes.

Note: When the ECM automatically calibrates new duty cycle values for the low idle throttle position and the high idle throttle position the ECM assumes 22 percent duty cycle at low idle and 75 percent duty cycle at high idle. As a result, you may notice that the throttle position status reaches 100 percent well before the accelerator pedal is fully depressed. This is normal. After some cycling of the accelerator pedal to the high idle position, the ECM will adjust the calibration automatically. The ECM will adjust the calibration automatically provided that the high idle stop position is within the 75 to 90 percent duty cycle range, and the low idle is in the 10 to 22 percent duty cycle range. During normal operation, you may also notice that more movement of the accelerator pedal is required for the throttle position status to increase above 3 percent. You may also observe that the status reaches the 100 percent value prior to the limit of the high idle position. This is done in order to ensure that the throttle reaches these two critical points for engine operation.

Expected Result:

Result 1 Diagnostic Code 91-08 or 91-13 is Active.

Result 2 Diagnostic Code 41-03 or 41-04 is Active.

Result 3 There are no active diagnostic codes that are related to the accelerator pedal position sensor circuit at this time, but a problem is suspected with operation of the accelerator pedal position sensor circuit.

Results:

- Result 1 – Proceed to Test Step 3.
- Result 2 – Proceed to Test Step 5.
- Result 3 – Proceed to Test Step 3.

Test Step 3. Check the Duty Cycle of the Accelerator Pedal Position Sensor

- A. Connect ET to the cab data link connector.
- B. Turn the ignition key switch to the ON position.
- C. Monitor the duty cycle of the throttle sensor on ET. Access the following display screen in order:
 - “Service”
 - “Calibrations”
 - “Monitor Throttle Position Sensor”

Expected Result:

The duty cycle is between 10 and 22 percent with the accelerator pedal assembly in the Low Idle position, and the duty cycle is between 75 and 90 percent with the accelerator pedal assembly in the High Idle position.

Results:

- OK – The accelerator pedal position sensor is operating correctly. Proceed to Test Step 6.
- Not OK – The accelerator pedal position sensor circuit is not operating correctly. Proceed to Test Step 4.

Test Step 4. Check the Supply Voltage at the Sensor for the Accelerator Pedal Position Sensor

- A. Install a breakout T with 3 terminals at the accelerator pedal position sensor connector J403/P403.
- B. Turn the ignition key switch to the ON position.
- C. Measure the voltage at terminal “A” (+8 V) with reference to terminal “B” (Accelerator/Switch Sensor Common).

Expected Result:

The measured voltage is between 7.5 VDC and 8.5 VDC for the pedal mounted throttle position sensor that is used in the cab.

Results:

- OK – Proceed to Test Step 8.
- Not OK – The sensor is not receiving the correct voltage. Proceed to Test Step 5.

Test Step 5. Monitor ET while the Accelerator Pedal Position Sensor is Being Disconnected

A. Access the active diagnostic code screen on ET. Ensure that one of the following diagnostic code is active before proceeding:

- 41-03 8 Volt Supply Above Normal (21)
- 41-04 8 Volt Supply Below Normal (21)

B. Monitor the active diagnostic code screen while the accelerator pedal position sensor is being disconnected and reconnected.

Expected Result:

One of the following diagnostic codes is still active after the accelerator pedal position sensor has been disconnected:

- 41-03 8 Volt Supply Above Normal (21)
- 41-04 8 Volt Supply Below Normal (21)

Results:

- OK – Ensure that the accelerator pedal position sensor has been reconnected before continuing. Proceed to Test Step 7.
- Not OK

Repair: Perform the following diagnostic procedure:

Temporarily install another accelerator pedal position sensor. Use ET to check for an active +8 V diagnostic code. Replace the accelerator pedal position sensor if both of the following conditions occur:

- The problem is corrected with the new accelerator pedal position sensor.
- The problem returns after the old accelerator pedal position sensor has been reconnected.

STOP.

Test Step 6. Check the Status of the PTO On/Off Switch and the Status of the Power Train Data Link with ET

A. Check the status of the “PTO ON/OFF Switch” on ET in order to verify that the “PTO ON/OFF Switch” is off. The PTO mode may cause the ECM to ignore the accelerator pedal position sensor if the “PTO Configuration” is programmed to one of the following parameters:

- Remote Switches
- Remote Throttle
- Cab Switches

Note: If the “PTO Configuration” is programmed to “Cab Switches” and the “PTO Cab Controls RPM Limit” is programmed to “Low Idle”, the PTO mode may cause the ECM to ignore the accelerator pedal position sensor. This will occur when the “PTO ON/OFF Switch” is in the ON position.

B. Start the engine. While the “Throttle Position” status is being monitored on ET, depress the accelerator pedal and release the accelerator pedal. The “Throttle Position” status and the engine should respond to the change in the accelerator pedal position.

C. Go to the “System Troubleshooting Settings” portion of ET and turn off the “Power Train Data Link”.

D. While the “Throttle Position” status is being monitored on ET, depress the accelerator pedal and release the accelerator pedal. Also depress the accelerator pedal and release the accelerator pedal while the engine response is being monitored.

Expected Result:

The “Throttle Position” status and the engine should respond to the change in the accelerator pedal position.

Result 1 The cab accelerator functions properly.

Result 2 The throttle response is limited by a power train data link message.

Result 3 The PTO limits the throttle response.

Results:

- **Result 1** – The accelerator pedal position sensor is operating correctly. Continue troubleshooting until the original condition is resolved. **STOP.**

- **Result 2** – If the engine responds with the “Power Train Data Link” in a disabled condition and the engine does not respond with the “Power Train Data Link” in an enabled condition, a component of the “Power Train Data Link” is causing the response problem of the accelerator pedal position sensor. Send the truck to the vehicle manufacturer in order to repair the faulty component of the “Power Train Data Link”. **STOP.**

- **Result 3** – The ECM is operating in PTO mode.

Repair: If the PTO should not be active, refer to the following diagnostic procedure: Troubleshooting, “PTO Switch Circuit - Test”

STOP.

Test Step 7. Disconnect the Power Supply Connections for the Accelerator Pedal Position Sensor at the ECM

- A.** Turn the ignition key switch to the OFF position.
- B.** Remove P1:4 (+8 V) and remove P1:5 (Accelerator/Switch Sensor Common) from vehicle harness connector P1. Disconnect ECM vehicle harness connector J1/P1, if necessary.
- C.** Reconnect ECM connector J1/P1.
- D.** Turn the ignition key switch to the ON position.
- E.** Use ET to check for active diagnostic codes.

Expected Result:

One of the following diagnostic codes is still active after the terminals for sensor power have been disconnected:

- 41-03 8 Volt Supply Above Normal (21)
- 41-04 8 Volt Supply Below Normal (21)

Results:

- **OK**

Repair: Perform the following repair:

Check the battery voltage from P1:51 & 53 (Unswitched +Battery) to P1:65 & 67 (-Battery). The measured voltage should be in one of the following ranges:

- For 12 Volt Systems, the voltage should be between 11.0 VDC and 13.5 VDC.
- For 24 Volt Systems, the voltage should be between 22.0 VDC and 27.0 VDC.

If the battery voltage is correct, temporarily connect a test ECM. Use ET to verify that the active diagnostic code is resolved. If the problem is corrected with the test ECM, reconnect the suspect ECM. Verify that the active diagnostic code returns. If the active diagnostic code returns with the suspect ECM, replace the ECM.

STOP.

- **Not OK**

Repair: Perform the following repair:

There is a problem in the wiring between the ECM and the accelerator pedal position sensor. While active diagnostic codes are being monitored, connect the removed wires one at a time in order to verify that the active diagnostic codes reappear. First connect P1:5 and then connect P1:4. This procedure is used to find the wire that is causing the problem. Repair the wire or replace the wire, as required. Verify that the repair eliminates the problem.

STOP.

Test Step 8. Check the Duty Cycle of the Accelerator Pedal Position Sensor at the Sensor

Note: Performing certain steps within this procedure requires the use of a multimeter that is capable of measuring a PWM duty cycle.

- A.** Turn the ignition key switch to the OFF position.
- B.** Remove the signal wire for the accelerator pedal position sensor (terminal “C”) from P403. This is the vehicle harness side of the accelerator pedal position sensor connector.
- C.** Install a breakout T with 3 terminals at the accelerator pedal position sensor connector J403/P403.
- D.** Connect the multimeter probes to terminal “C” (Accelerator Pedal Position) and terminal “B” (Accelerator/Switch Sensor Common) of the breakout T.
- E.** While the duty cycle is being monitored on the multimeter, depress the accelerator pedal and release the accelerator pedal.

Expected Result:

The duty cycle is between 10 and 22 percent with the accelerator pedal assembly in the Low Idle position, and the duty cycle is between 75 and 90 percent with the accelerator pedal assembly in the High Idle position.

Results:

- **OK** – Reinsert the wire (terminal “C”) into the vehicle harness connector. The accelerator pedal position sensor is working correctly. Proceed to Test Step 9.
- **Not OK** – Leave the PWM probe connected to the breakout T. Insert the wire (terminal “C”) into the vehicle harness connector. The accelerator pedal position sensor or the accelerator pedal assembly is faulty. Proceed to Test Step 10.

Test Step 9. Check the Duty Cycle of the Accelerator Pedal Position Sensor at the ECM

Note: Performing certain steps within this procedure requires the use of a multimeter that is capable of measuring a PWM duty cycle.

- A.** Turn the ignition key switch to the OFF position.
- B.** Remove the wire for the accelerator pedal position sensor P1:66. You may be required to disconnect ECM connector P1 in order to remove the terminal for the signal input of the accelerator pedal position sensor.
- C.** Connect the multimeter probes between the removed wire and P1:5 (Accelerator/Switch Sensor Common).
- D.** Reconnect ECM connector P1 to the ECM.
- E.** Turn the ignition key switch to the ON position.
- F.** Use the multimeter in order to display the duty cycle output of the accelerator pedal position sensor. While the duty cycle output of the accelerator pedal position sensor is being monitored on the multimeter, move the accelerator assembly from the Low Idle position to the High Idle position. Record the results.
- G.** Turn the ignition key switch to the OFF position.
- H.** Insert P1:66 into the ECM vehicle connector P1.

Expected Result:

The duty cycle is between 10 and 22 percent with the accelerator pedal assembly in the Low Idle position, and the duty cycle is between 75 and 90 percent with the accelerator pedal assembly in the High Idle position.

Results:

- **OK** – A good signal from the accelerator pedal position sensor is reaching the ECM. Verify that the ECM is receiving the proper battery voltage. If the ECM is receiving the proper battery voltage, temporarily connect a test ECM and verify that the problem is resolved. If the problem disappears with the test ECM, reconnect the suspect ECM. If the problem returns with the suspect ECM, replace the ECM. **STOP.**
- **Not OK** – There is a problem with signal wire for the accelerator pedal position sensor in the vehicle wiring harness. Proceed to Test Step 11.

Test Step 10. Remove the Accelerator Pedal Position Sensor from the Accelerator Pedal Assembly

- A.** Turn the ignition key switch to the OFF position.
- B.** Remove the accelerator pedal position sensor from the accelerator pedal assembly. Note sensor orientation in the accelerator pedal assembly, and the sensor pigtail routing prior to sensor removal. Thoroughly inspect the pigtail for signs of abrasion.
- C.** Connect the multimeter that is capable of measuring a PWM duty cycle to terminal “C” of the breakout T.
- D.** Turn the ignition key switch to the ON position.
- E.** Display the duty cycle output of the accelerator pedal position sensor while the sensor slot is released. Use a screwdriver to advance the sensor slot to the maximum position. Refer to Illustration 26.

When the sensor is removed from the accelerator pedal assembly, the following diagnostic code may be generated:

- 91-13 Throttle Sensor Calibration (28)

This is normal. The diagnostic code should disappear when the sensor is properly assembled back into the accelerator pedal assembly.

- A Mate sensor to accelerator pedal assembly. Key must match up with the sensor slot. Check the sensor housing for a flush fit to the pedal assembly mounting surface (This ensures slot on sensor has mated correctly with the pedal assembly key.)
- B Ensure the sensor is oriented the same as it was prior to removal to ensure sensor harness pigtail is routed correctly.
- C Line up screw holes and install mounting screws.

NOTE: Procedure is identical for the suspended accelerator pedal assembly.

Accelerator Pedal Assembly

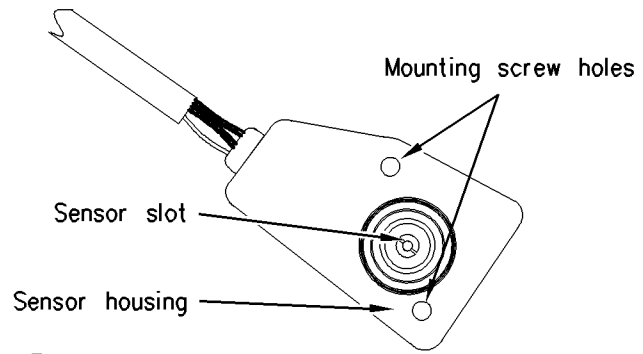
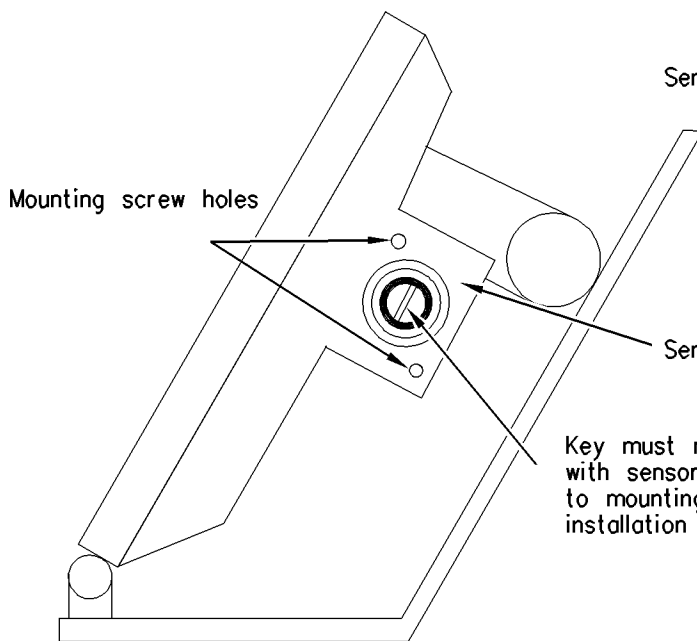

Accelerator Block Assembly

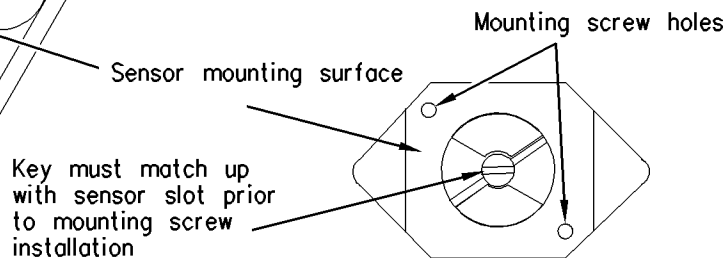

Accelerator Block Assembly

Illustration 26
Accelerator pedal assembly

g00706977

Expected Result:

When the sensor is removed from the accelerator pedal assembly and the sensor slot is released, the duty cycle is 10 percent or less. When the sensor slot is moved to the maximum position, the duty cycle increases to 90 percent or more.

Results:

- **OK** – The accelerator pedal position sensor is working correctly. Clear any diagnostic codes that were caused by performing this test procedure. Refer to the OEM dealer for correct replacement of the accelerator pedal assembly. **STOP.**

- **Not OK** – The accelerator pedal position sensor is faulty. Check the accelerator pedal assembly in order to ensure that the accelerator pedal assembly is not causing damage to the sensor. If the accelerator pedal assembly is causing damage to the sensor, refer to the OEM dealer for correct replacement of the accelerator pedal assembly. If the accelerator pedal assembly appears OK, replace the accelerator pedal position sensor. **STOP.**

Test Step 11. Route the Supply Bypass Wires to the Accelerator Pedal Position Sensor

- A. Turn the ignition key switch to the OFF position.

- B.** Remove the signal wire for the accelerator pedal position sensor from the ECM Connector P1:66.
- C.** Remove terminal "C" (Accelerator Pedal Position) from the accelerator pedal position sensor connector.
- D.** Route new wiring from the ECM to the accelerator pedal position sensor.
- E.** Turn the ignition key switch to the ON position.
- F.** Check the duty cycle of the accelerator pedal position sensor on ET while the accelerator pedal assembly is being moved over the full range.

Expected Result:

The duty cycle is between 10 and 22 percent with the accelerator pedal assembly in the Low Idle position, and the duty cycle is between 75 and 90 percent with the accelerator pedal assembly in the High Idle position.

Results:

- OK

Repair: Perform the following repair:

The wiring from the ECM to the accelerator pedal position sensor appears faulty. Permanently install new wiring.

Verify that the repair eliminates the problem.

STOP.

- Not OK – Double check the wiring, the ECM vehicle harness connector J1/P1 and the sensor connector. If a problem still exists, restart the test procedure. STOP.

i01857574

Air Inlet Heater Circuit - Test

SMCS Code: 1090-081

System Operation Description:**Use this procedure under the following situation:**

Use the following information in order to troubleshoot the air inlet heater circuit when there is an active code:

- 70-05 Inlet Air Heater Open Circuit (49)
- 70-06 Inlet Air Heater Short Circuit (49)

This procedure can also be used to troubleshoot the following components:

- The air inlet heater
- The air inlet heater relay
- The lamp for the air inlet heater

The following background information is related to the following procedure:

The use of the air inlet heater improves the engines' ability to start when the engine is cold. A reduction of white smoke is also a benefit of the air inlet heater.

The ECM controls the operation of the air inlet heater and the ECM controls the operation of the lamp for the air inlet heater through the air inlet heater relay.

The operation of the air inlet heater is determined by three different cycle times:

- ECM Powerup and Preheat Cycle
- Cranking
- Engine Started

The cycle time is determined by the following parameters:

- Engine parameters
- Vehicle speed
- Service brake

Effects of Vehicle Speed on the Operation of the Air Inlet Heater and on the Operation of the Brake Pedal Position.

The air inlet heater is turned off when the brake pedal is depressed and the vehicle speed is equal to 8 km/h (5 mph) or greater than 8 km/h (5 mph).

If a diagnostic code for the vehicle speed sensor is active, the ECM will assume that the vehicle speed is above 8 km/h (5 mph). If an active diagnostic code is triggered for the vehicle speed sensor, the ECM will disable the heater when the brakes are applied.

The ECM Powerup and Preheat Cycle.

The lamp for the air inlet heater should turn on for a minimum of 2 seconds when the ECM is first powered up. The lamp should turn on regardless of the coolant temperature. The ECM will signal the air inlet heater to stay on for 30 seconds if the sum of the coolant temperature and the inlet manifold air temperature is less than 25 degrees Celsius or 109 degrees Fahrenheit.

The air inlet heater and the lamp for the air inlet heater should turn on. The air inlet heater and the lamp for the air inlet heater should turn off when the cycle is complete.

The ECM will control the air inlet heater for the "Cranking Cycle" if the operator starts the engine before the end of the heating cycle.

Control of the Air Inlet Heater During Cranking

If the sum of the coolant temperature and the inlet manifold air temperature is less than 25 degrees Celsius or 109 degrees Fahrenheit, the air inlet heater will turn on when the engine is cranking. The heater will remain on while the engine is cranking. The air inlet heater will reactivate for 30 seconds if the engine fails to start.

Engine Start Cycle

The operation of the air inlet heater is determined by the coolant temperature and the inlet manifold air temperature after the engine has started. If the combined temperature is less than 25 degrees Celsius or 109 degrees Fahrenheit, the engine start cycle begins. The engine start cycle has two segments:

- Continuous Mode
- On/Off Cycling Mode

The Continuous Mode lasts for a maximum of seven minutes. The On/Off Cycling Mode can last for a maximum of thirteen minutes. The air inlet heater is turned on and the air inlet heater is turned off for ten seconds during the On/Off Cycling Mode. The air inlet heater will turn off when the sum of the coolant temperature and the inlet manifold air temperature exceeds 35 degrees Celsius or 127 degrees Fahrenheit.

Note: MAY99 and newer Personality Modules use the boost pressure reading to determine atmospheric pressure. This will indicate if the engine is operating above 1678 m (5505 ft). If the altitude is above 1678 m (5505 ft), the temperature calculation is adjusted in order to compensate for the extreme altitude. The temperature calculation is used in order to determine the operation of the air inlet heater. Refer to Illustration 31 for more details.

Active Open Circuit or Short Circuit Diagnostic Codes

The air inlet heater will turn on if the coolant temperature sensor has an active open circuit diagnostic code or an active short circuit diagnostic code and the inlet manifold air temperature is less than 10 °C (50 °F).

The air inlet heater will turn on if the air temperature sensor for the inlet manifold has an active open circuit diagnostic code or an active short circuit diagnostic code and the coolant temperature is less than 40 °C (104 °F).

Note: The coolant temperature and the inlet manifold temperature are measured in degree Celsius. An electronic service tool can display the coolant temperature and the inlet manifold temperature in degree Celsius or in degree Fahrenheit. The ECM adds the coolant temperature and the inlet manifold temperature together. Then, the ECM uses the sum of the coolant temperature and the air inlet temperature in order to determine if the air inlet heater should be on or off. Illustration 31 is a visual aid for troubleshooting the operation of the air inlet heater. The temperatures in degree Fahrenheit are not a direct conversion of the temperatures in degree Celsius.

The following procedure explains the temperatures that are shown in degree Fahrenheit:

- Convert the reading for the coolant temperature from degree Celsius to degree Fahrenheit.
- Convert the reading for the inlet manifold temperature from degree Celsius to degree Fahrenheit.
- Add the two conversions together in order to arrive at the correct conversion for the sum in degree Fahrenheit.

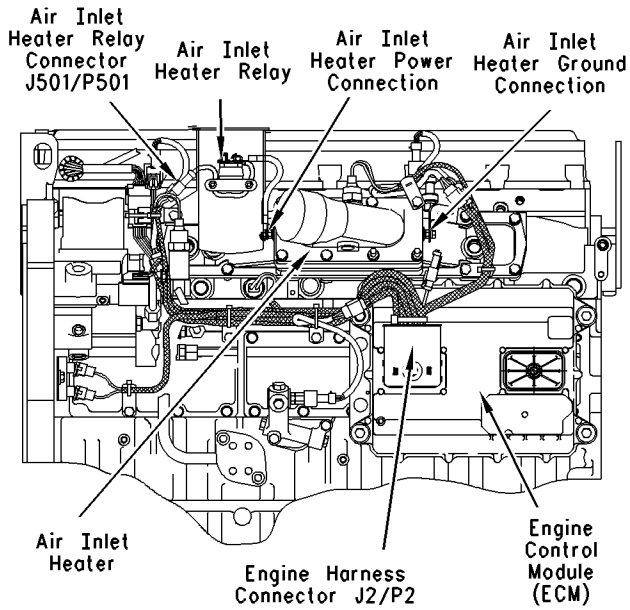

Illustration 27 g00726351
The Diagram for the air inlet heater

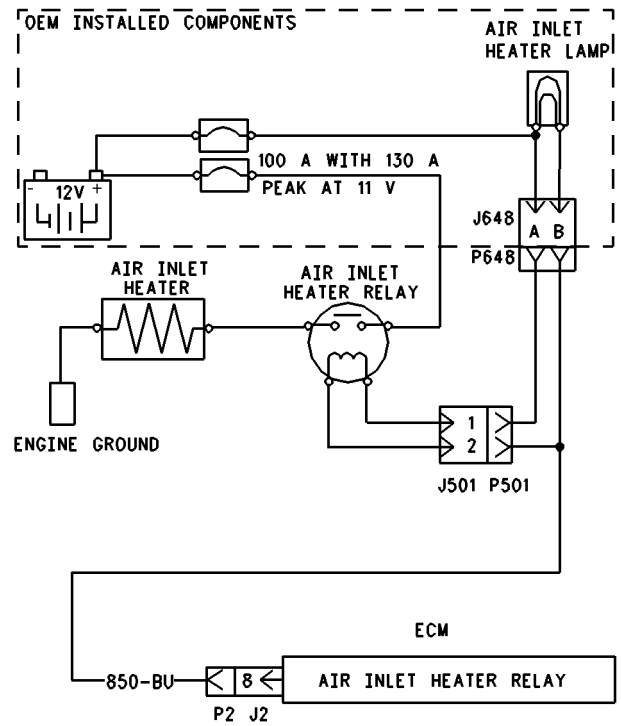

Illustration 29 g00726687
Schematic of the air inlet heater

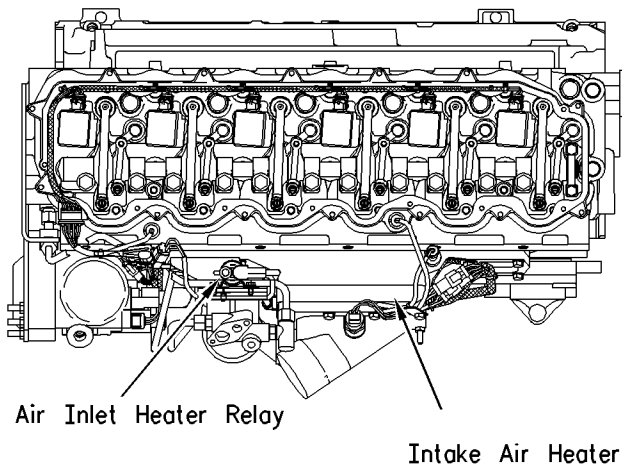

Illustration 28 g00726347
Top engine view

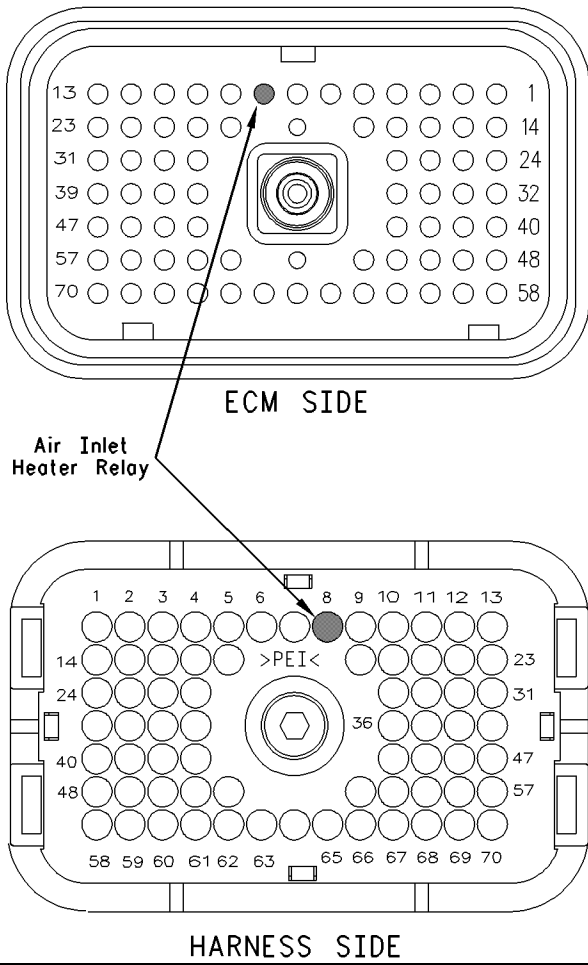
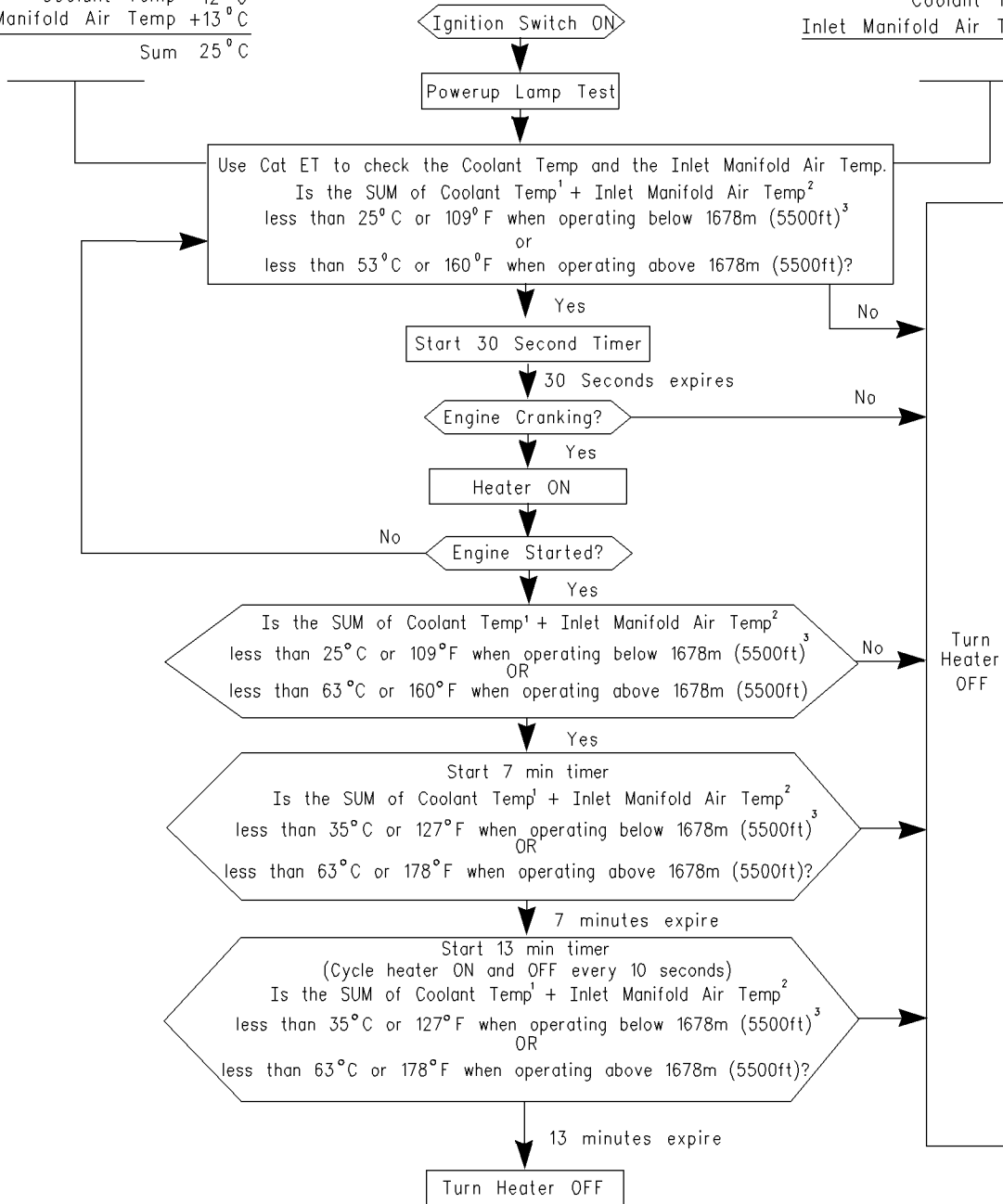

Illustration 30
Connections for the ECM terminals

g00726706

EXAMPLE
Cat ET set to display Celsius
Coolant Temp 12 °C
Inlet Manifold Air Temp +13 °C
Sum 25 °C

EXAMPLE
Cat ET set to display Fahrenheit
Coolant Temp 54 °F
Inlet Manifold Air Temp +55 °F
Sum 109 °F



- ¹ If a coolant temperature sensor open circuit or short circuit diagnostic code is active, the heater will come ON if Inlet Manifold air temperature <10°C (50°F)
- ² If an Inlet Manifold air temperature sensor open circuit or short circuit diagnostic code is active, the heater will come ON if coolant temperature <40°C (140°F)
- ³ The Boost Pressure reading is used to determine Atmospheric Pressure. This indicates if the engine is operating above 1678m (5500ft). If so, the temperature calculations used to determine Inlet Air Heater operation are adjusted to compensate for the extreme altitude operation.

NOTE: If the Service Brake Switch is open with the Vehicle Speed greater than or equal to 8km/h (5 mph), or if a vehicle speed diagnostic is present, the heater will be turned OFF.

Test Step 1. Inspect Electrical Connectors And Wiring

- A. Thoroughly inspect the connector J501/P501 for the air inlet heater relay and inspect the ECM engine harness connector J2/P2. Inspect the electrical connector J648/P648 for the lamp of the air inlet heater and inspect the terminal connections on the air inlet heater relay. Refer to Troubleshooting, “Electrical Connectors - Inspect” for details.
- B. Perform a 45 N (10 lb) pull test on each of the wires in the ECM connector that are associated with the air inlet heater (terminal 8).
- C. Check the ECM connector (allen head screw) for the proper torque of 6.0 N·m (55 lb in).
- D. Check the harness and wiring for abrasion and for pinch points from the sensors back to the ECM.

Expected Result:

All connectors, pins and sockets should be completely coupled and/or inserted and the harness and wiring should be free of corrosion, abrasion or pinch points.

Results:

- OK – Proceed to Test Step 2.
- Not OK

Repair: Perform the following repair:

Repair the connectors or wiring and/or replace the connectors or wiring. Ensure that all of the seals are properly in place and ensure that the connectors are completely coupled.

Verify that the repair eliminates the problem.

STOP.

Test Step 2. Use the “Intake Air Heater Enable Test” to Check the Circuit

- A. Turn the ignition key switch to the ON position.
- B. The lamp for the air inlet heater should illuminate for two seconds. The lamp for the air inlet heater should shut off.
- C. Connect the electronic service tool to the cab data link connector.
- D. Go to the “Intake Air Heater Enable Test” on the electronic service tool.

- E. Start the test and listen for a click from the air inlet heater relay.

Note: The air inlet heater relay is located on the front left side of the engine.

Note: Do not leave the “Intake Air Heater Enable Test” on. Avoid unnecessary cycling of the air inlet heater in order to prevent the battery from discharging. The “Intake Air Heater Enable Test” has a one minute timer in order to disable the test when the time expires.

Expected Result:

Result 1 The lamp and the relay activate.

Result 2 The lamp and the relay activate. The air inlet heater is still suspect.

Result 3 The lamp activates but the relay does not activate.

Result 4 The lamp does not activate.

Results:

- **RESULT 1** – The lamp and the relay are functioning normally. **STOP.**
- **RESULT 2** – Proceed to Test Step 3.
- **RESULT 3** – There is a problem with the relay circuit. Proceed to Test Step 4.
- **RESULT 4** – Proceed to Test Step 5.

Test Step 3. Check the Voltage at the Relay Contacts for the Air Inlet Heater

- A. Turn the ignition key switch to the OFF position.
- B. Disconnect the wire from the relay terminal of the air inlet heater to the air inlet heater.
- C. Fabricate two jumper wires with Deutsch sockets on one end and Deutsch pins on the other end. Strip a small amount of insulation from the middle of one jumper wire.

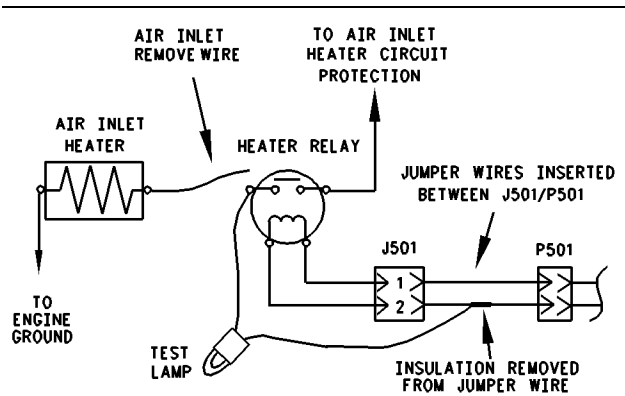

Illustration 32
Connections for the Test Lamp
g00726988

- D. Disconnect J501/P501 and insert the jumper wires in the electrical connectors.
- E. Connect a voltage test lamp from the disconnected relay terminal to the jumper wire that is connected to J501 and P501 terminals.
- F. Turn the ignition key switch to the ON position.
- G. Go to the "Intake Air Heater Enable Test" on the electronic service tool.
- H. Start the test and watch the voltage test lamp.

Note: Do not leave the "Intake Air Heater Enable Test" on. Avoid unnecessary cycling of the air inlet heater in order to prevent the battery from discharging. The "Intake Air Heater Enable Test" has a one minute timer in order to disable the test when the time expires.

Expected Result:

The test lamp turned on and the test lamp turned off with the "Intake Air Heater Enable Test".

Results:

- Yes

Repair: The air inlet heater relay and the +battery connection to the air inlet heater relay are OK. Leave the wire disconnected from the relay terminal.

Proceed to Test Step 6.

- No

Repair: The test lamp does not come on or the test lamp remains on after the test lamp comes on.

Reconnect the wire to the relay terminal.

Proceed to Test Step 7.

Test Step 4. Check the Voltage at the Electrical Connector P501 for the Air Inlet Heater Relay

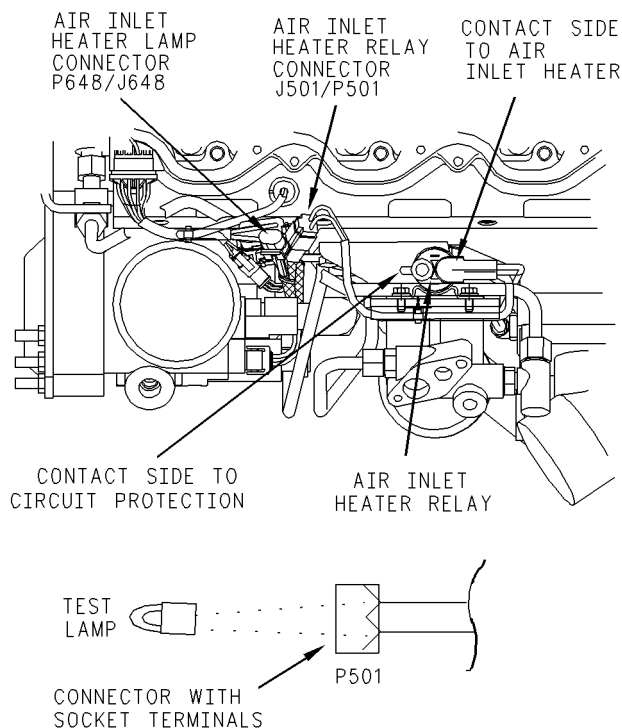

Illustration 33
g00727002

- A. Disconnect the connector J501/P501 for the air inlet heater relay.
- B. Ensure that the connector J648/P648 for the air inlet heater's lamp is still connected.
- C. Connect a voltage test lamp to the two terminals of the engine harness side P501 connector of the air inlet heater relay.
- D. Turn the ignition key switch to the ON position.
- E. Go to the "Intake Air Heater Enable Test" on the electronic service tool.
- F. Start the test and watch the voltage test lamp.

Note: Do not leave the "Intake Air Heater Enable Test" on. Avoid unnecessary cycling of the air inlet heater in order to prevent the battery from discharging. The "Intake Air Heater Enable Test" has a one minute timer in order to disable the test when the time expires.

Expected Result:

The test lamp turns on and the test lamp turns off with the "Intake Air Heater Enable Test".

Results:

- Yes

Repair: Replace the air inlet heater and rerun the test. Verify that the original problem has been resolved.

STOP.

- No

Repair: The connector P501 for the air inlet heater relay is not receiving the correct voltage.

Proceed to Test Step 8.

Test Step 5. Check the Voltage at the Lamp for the Air Inlet Heater

- Turn the ignition key switch to the OFF position.
- Locate the lamp in the dash for the air inlet heater. Remove the lamp from the dash.
- Connect a voltage test lamp between the two terminals of the lamp socket.
- Turn the ignition key switch to the ON position.
- Go to the "Intake Air Heater Enable Test" on the electronic service tool.
- Start the test and watch the voltage test lamp.

Note: Do not leave the "Intake Air Heater Enable Test" on. Avoid unnecessary cycling of the air inlet heater in order to prevent the battery from discharging. The "Intake Air Heater Enable Test" has a one minute timer in order to disable the test when the time expires.

Expected Result:

The test lamp turns on and the test lamp turns off with the "Intake Air Heater Enable Test".

Results:

- Yes

Repair: Replace the lamp for the air inlet heater. Verify that the problem has been resolved.

STOP.

- No – Reinstall the lamp for the air inlet heater. Proceed to Test Step 9.

Test Step 6. Check the Wiring for the Air Inlet Heater

- Turn the ignition key switch to the OFF position.
- Disconnect both wires from the air inlet heater.
- Use a multimeter to measure the resistance between the two ends of the wire that connects the air inlet heater to the air inlet heater relay.
- Measure the resistance from the engine ground stud to the other end of the wire for the air inlet heater that connects to the ground stud.

Expected Result:

The measured resistance is less than 20 Ohms.

Results:

- Yes

Repair: Replace the air inlet heater. Verify that the problem is resolved.

STOP.

- No

Repair: Repair the damaged wire. Verify that the problem is resolved.

STOP.

Test Step 7. Check the Relay Contact at the +Battery Terminal Connection.

- Turn the ignition key switch to the OFF position.

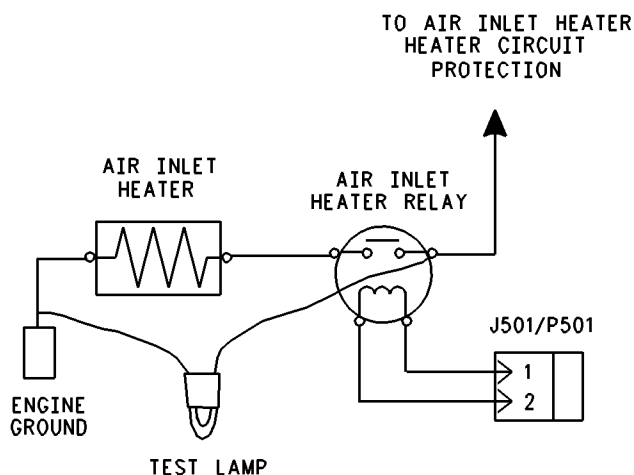

Illustration 34
Connections for the Test Lamp

- B. Connect a voltage test lamp from the terminal for the relay contact that connects to the circuit protection for the air inlet heater (wire K995-OR).
- C. Connect the other end of the voltage test lamp to the engine ground stud.
- D. Turn the ignition key switch to the ON position.

Expected Result:

The test lamp comes on when the ignition key switch is turned to the ON position.

Results:

- Yes

Repair: Repair the wiring between the lamp for the air inlet heater and the connector J648:B. Verify that the problem has been resolved.

STOP.

- No

Repair: Inspect the circuit protection for the air inlet heater and the air inlet heater wiring. Repair the wiring. Verify that the problem has been resolved.

STOP.

Test Step 8. Check the Battery Voltage to Connector J648 for the Lamp

- A. Turn the ignition key switch to the OFF position.

- B. Disconnect the connector J648/P648 for the air inlet heater's lamp.
- C. Connect a voltage test lamp to the terminal J648:A. Refer to Illustration 33.
- D. Connect a jumper wire to the ground stud. Connect the other lead of the test lamp to the jumper wire.
- E. Turn the ignition key switch to the ON position.

Expected Result:

The voltage test lamp came on and the voltage test lamp stays on while the voltage test lamp is connected between J648:A and the ground stud.

Results:

- Yes – Proceed to Test Step 10.
- No

Repair: Repair the wiring. Verify that the problem has been resolved.

STOP.

Test Step 9. Check the Voltage at Connector J648/P648 for the Lamp

- A. Turn the ignition key switch to the OFF position.
- B. Disconnect the connector J648/P648 for the air inlet heater's lamp.
- C. Connect a voltage test lamp from the connector J648:A for the air inlet heater to the engine ground stud.
- D. Turn the ignition key switch to the ON position.

Expected Result:

The test lamp comes on and the test lamp stays on.

Results:

- Yes

Repair: Repair the wiring from the connector J648:B for the lamp. Verify that the problem has been resolved.

STOP.

- No

Repair: Repair the wiring from connector J648:A for the lamp. Verify that the problem has been resolved.

STOP.

Test Step 10. Check Battery Voltage to the Connector P501 for the Air Inlet Heater Relay

- A. Turn the ignition key switch to the OFF position.
- B. Ensure that the connector J648/P648 for the air inlet heater's lamp is connected.
- C. Disconnect the connector J501/P501 for the air inlet heater relay.
- D. Connect a voltage test lamp from the connector P501:1 for the air inlet heater relay to the engine ground stud.
- E. Turn the ignition key switch to the ON position.

Expected Result:

The voltage test lamp comes on and the voltage test lamp stays on when the ignition key switch is in the ON position.

Results:

- Yes – Proceed to Test Step 11.
- No

Repair: Repair the wiring from J648:A to P501:1. Verify that the problem is resolved.

STOP.

Test Step 11. Check the ECM

- A. Turn the ignition key switch to the OFF position.
- B. Disconnect the connector J648/P648 for the air inlet heater's lamp.

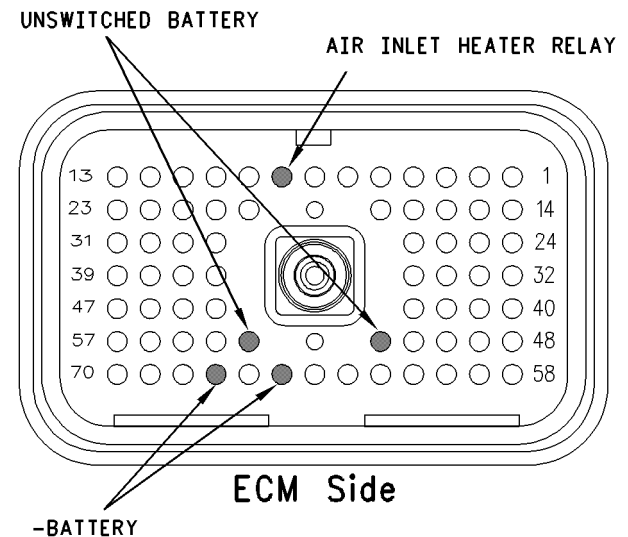

Illustration 35
Connections for the Breakout T

g00727433

- C. Disconnect the ECM engine harness connector J2/P2. Install a breakout T on the ECM connector J2 only.
- D. Connect a voltage test lamp from the connector J648:A to the terminal 8 of the breakout T. Refer to Illustration 34.
- E. Turn the ignition key switch to the ON position.
- F. Go to the "Intake Air Heater Enable Test" on the electronic service tool.
- G. Start the test and watch the voltage test lamp.

Note: Do not leave the "Intake Air Heater Enable Test" on. Avoid unnecessary cycling of the air inlet heater in order to prevent the battery from discharging. The "Intake Air Heater Enable Test" has a one minute timer in order to disable the test when the time expires.

Note: When ECM engine harness connector J2/P2 is disconnected and the ignition key switch is in the ON position, open circuit diagnostic codes will be active or logged for all of the engine sensors. This is normal.

Expected Result:

The test lamp turned on and the test lamp turned off with the "Intake Air Heater Enable Test".

Results:

- Yes

Repair: Repair the wiring from the connector P501 for the air inlet heater relay to the ECM connector P2. Verify that the problem has been resolved.

STOP.

- No – Proceed to Test Step 12.

Test Step 12. Test the Battery Voltage to the ECM

- Turn the ignition key switch to the OFF position.
- Disconnect the ECM vehicle harness connector J1/P1 and install a breakout T.
- Connect a voltmeter between terminal 52 of the breakout harness and terminal 65 of the breakout harness. Refer to Illustration 35.
- Turn the ignition key switch to the ON position and check the voltmeter.
- Turn the ignition key switch to the OFF position.
- Connect a voltmeter between terminal 53 of the breakout harness and terminal 67 of the breakout harness. Refer to Illustration 35.
- Turn the ignition key switch to the ON position and check the voltmeter.

Expected Result:

The voltage is between 11.0 VDC and 13.5 VDC when the ignition key switch is in the ON position.

Results:

- Yes

Repair: Replace the ECM. Verify that the problem is resolved.

STOP.

- No

Repair: Inspect the vehicle wiring. Repair the vehicle wiring or send the vehicle to the OEM dealer for repair. Verify that the problem has been resolved.

STOP.

i01631745

ATA (SAE J1587 / J1708) Data Link Circuit - Test

SMCS Code: 1408-081; 1901-081

System Operation Description:

Use this procedure under the following situation:

Use this procedure if ET will not power up or ET will not communicate with the ECM through the cab data link connector.

The following background information is related to this procedure:

The ATA data link (American Trucking Association) is the standard data link that is used by the ECM to communicate with electronic service tools. The SAE specification J1587 defines the format of the messages and data that is being communicated. The SAE specification J1708 defines the hardware requirements and the protocol of the serial communications. The Caterpillar Electronic Technician (ET) is an example of one of the electronic service tools. Some electronic dashboards use this data link to receive information. Some automatic transmissions also receive information from this data link.

The ECM provides the following two ATA data link connection terminals from the ECM vehicle harness connector J1:

- Terminal 9 (J1587 DATA LINK NEGATIVE)
- Terminal 8 (J1587 DATA LINK POSITIVE)

The vehicle OEM provides twisted pair wiring from the ECM to the cab data link connector.

Remember that there are potentially several devices that are installed in the vehicle and remember that these devices are connected to the ATA data link at one time. These devices include dash displays, trip recorders and transmission controls. These devices may cause problems with the data link. These problems can disrupt communications to the engine ECM and from the engine ECM.

Communication

When the ignition key switch is in the OFF position, the ECM may communicate with ET. The communications may be disrupted and the communications may require frequent reconnection. In order to avoid this problem, turn the ignition key switch to the ON position when ET is being used.

The Caterpillar Electronic Technician (ET) may indicate the following error message:

- The version of the ECM is not recognized and the integrity of the changed parameters and displayed data is not guaranteed.

This message will indicate that the latest version of the Electronic Technician has not been installed or this message will indicate that the software in the ECM is newer than the software for the Electronic Technician.

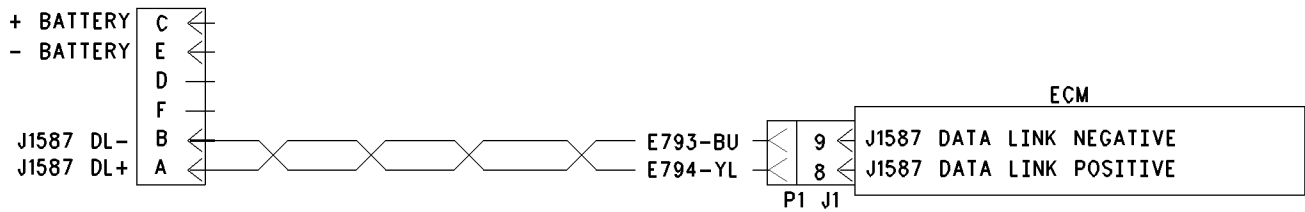

Illustration 36
 Schematic for ATA Data Link with 6-pin connector

g00650338

Test Step 1. Inspect Electrical Connectors And Wiring.

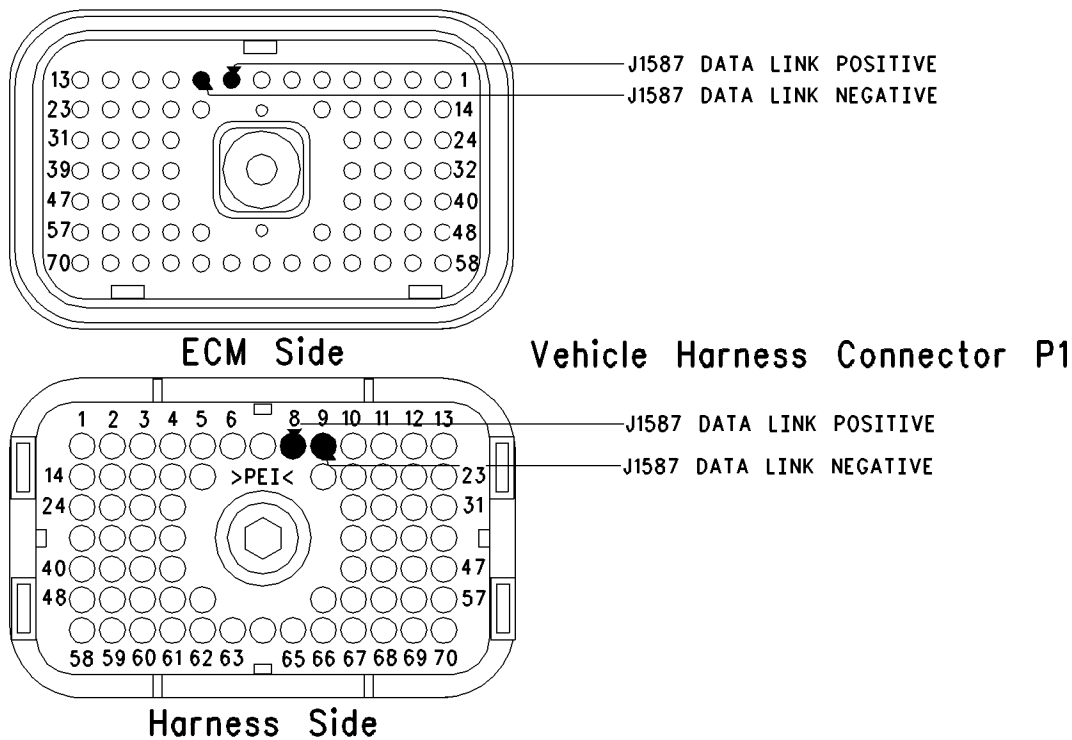

Illustration 37
 Terminal locations for ECM

g00650339

- A.** Thoroughly inspect the following electrical connectors:
- ECM vehicle harness connector J1/P1
 - cab data link connector
 - firewall bulkhead connector
 - Electronic service tool connectors
 - ATA data link (terminal 8 and terminal 9) in the connectors

Refer to Troubleshooting, "Electrical Connectors -Inspect" for details.

- B.** Perform a 45 N (10 lb) pull test on each of the wires in the ECM connector that are associated with the ATA data link.
- C.** Check the ECM connector (allen head screw) for the proper torque of 6.0 N·m (55 lb in).
- D.** Check the harness and wiring for abrasion and pinch points from the connector to the ECM.

Refer to Illustration 37.

Expected Result:

All connectors, pins and sockets should be completely coupled and/or inserted and the harness and wiring should be free of corrosion, abrasion or pinch points.

Results:

- **OK** – Proceed to Test Step 2.
- **Not OK**

Repair: Perform the following repair:

Repair the connectors or wiring and/or replace the connectors or wiring. Ensure that all of the seals are properly in place and ensure that the connectors are completely coupled.

Verify that the repair eliminates the problem.

STOP.

Test Step 2. Determine The Type Of Problem With The Data Link.

- A.** Connect ET to the cab data link connector.
- B.** Start the engine.

Expected Result:

Result 1 The engine starts. ET powers up and ET communicates without error.

Result 2 The engine starts. ET powers up but an error is displayed.

Result 3 The engine cranks but the engine will not start regardless of the condition of ET.

Result 4 The engine will not crank regardless of the condition of ET.

Result 5 The engine starts but ET does not power up.

Note: Check the display screen or check the communication adapter display in order to determine if ET has powered up. ET will display information that shows if the tool is receiving power. If ET or the communication adapter powers up, the cab data link connector is receiving power.

Results:

- **Result 1** – There is not a problem with the ATA data link at this time. If an intermittent condition exists, thoroughly inspect all wiring and connectors.

Repair: Perform the following diagnostic procedure:

Troubleshooting, "Electrical Connectors - Inspect"

STOP.

- **Result 2** – ET displays an error message. The ECM is receiving battery power. Proceed to Test Step 5.

- **Result 3** –

Repair: Perform the following diagnostic procedure:

Troubleshooting, "Engine Cranks But Will Not Start"

STOP.

- **Result 4** –

Repair: Perform the following diagnostic procedure:

Troubleshooting, "Engine Will Not Crank"

STOP.

- **Result 5** – ET does not power up or the communications adapter does not power up. Ensure that the ECM is receiving the correct battery power. Proceed to Test Step 3.

Test Step 3. Check the Battery Voltage Supply to the Cab Data Link Connector.

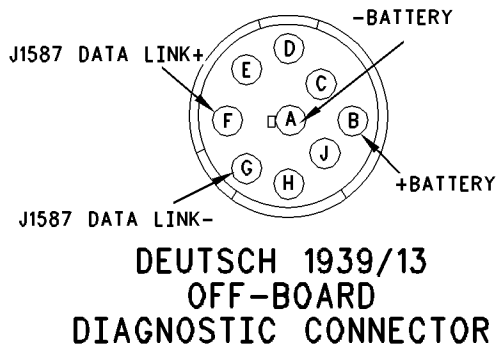
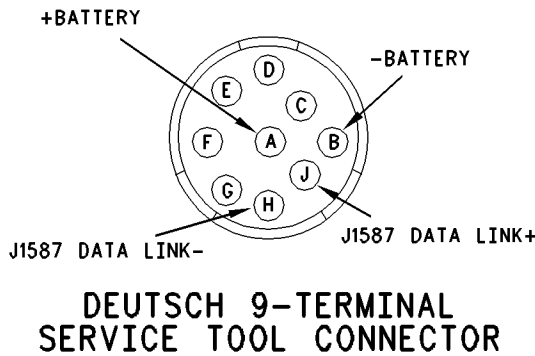
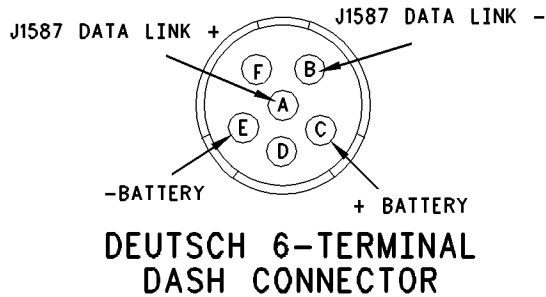

Illustration 38

g00764445

- A.** Turn the ignition key switch to the ON position.
- B.** Use a multimeter in order to measure the voltage from the + battery terminal of the cab data link connector to the - battery terminal of the cab data link connector.

Refer to Illustration 38.

Expected Result:

The voltage is between 11.0 and 13.5 VDC for a 12 Volt system or between 22.0 and 27.0 VDC for a 24 Volt system.

Results:

- **Yes** – The cab data link connector is currently receiving the correct voltage. Proceed to Test Step 4.
- **No** – The cab data link connector is not receiving the correct voltage.

Repair: Inspect the wiring and fuses to the connector. Repair the wiring or batteries and/or replace the wiring or batteries, as required. Send the vehicle to the OEM dealer for repair, if necessary.

Verify that the repair eliminates the problem.

STOP.

Test Step 4. Change ET Components.

- A.** If another vehicle or another ECM is available with a Caterpillar electronic engine, connect ET to the other vehicle by using the same cables.
- B.** Turn the ignition key switch to the ON position. Determine if ET operates correctly on the other vehicle.
- C.** If another engine is not available in the shop, find a different set of ET cables. Ensure that the set of cables is a complete set.
- D.** Connect ET to the cab data link connector by using the new cables.
- E.** Turn the ignition key switch to the ON position.
- F.** If changing cables allows ET to operate properly, use the following procedure:
 - a.** Replace the pieces from the old set of cables into the new set of cables that operates. Replace one piece at a time.
 - b.** Repower ET after each of the pieces is replaced. Use this method to find the faulty piece.
- G.** If changing cables does not allow ET to operate properly, connect another ET.
- H.** Turn the ignition key switch to the ON position.

Expected Result:

Result 1 The original ET works on another vehicle.

Result 2 A different ET works on the original vehicle while the engine is being tested.

Results:

- Result 1 – Proceed to Test Step 5.
- Result 2

Repair: Send the faulty ET for repairs.

STOP.

Test Step 5. Check the Battery Voltage at the ECM.

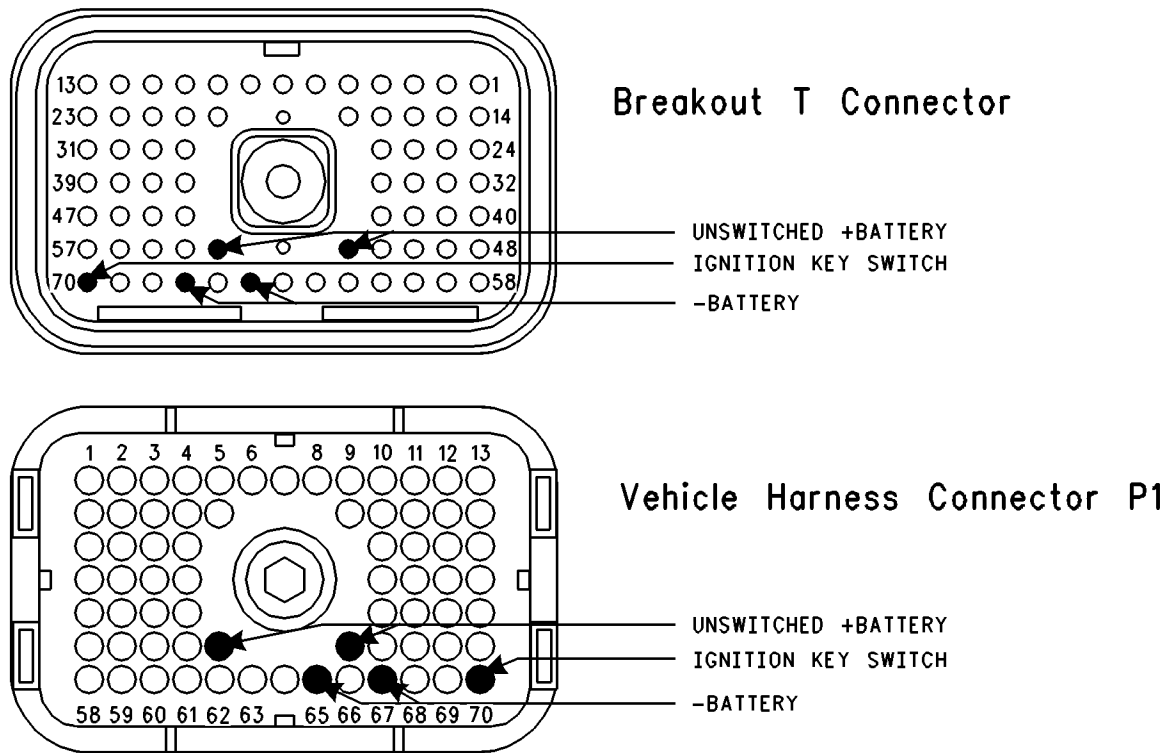

Illustration 39

g00650356

ECM Breakout T-connector and terminal locations for ECM P1

- A.** Ensure that ET is connected to the cab data link connector.
- B.** Disconnect vehicle harness connector P1 from ECM connector J1 and insert a breakout T.
- C.** Turn the ignition key switch to the ON position.
- D.** Measure the voltage between vehicle harness connector P1 terminal 52 (unswitched +battery) and terminal 65 (– battery).

- E.** Measure the voltage between vehicle harness connector P1 terminal 70 (ignition key switch) and terminal 65 (– battery).

Refer to Illustration 39.

Expected Result:

The voltage is between 11.0 and 13.5 VDC for a 12 Volt system or between 22.0 and 27.0 VDC for a 24 Volt system.

Results:

- **Yes** – The ECM is currently receiving the correct voltage. Proceed to Test Step 6.
- **No** – The ECM is not receiving the correct voltage. Ensure that there is not an aftermarket engine protection switch that is overriding battery power to the ECM.

Repair: Perform the following diagnostic procedure:

Troubleshooting, "Ignition Key Switch Circuit and Battery Supply Circuit - Test"

STOP.

Test Step 6. Connect the ET Directly to the ECM.

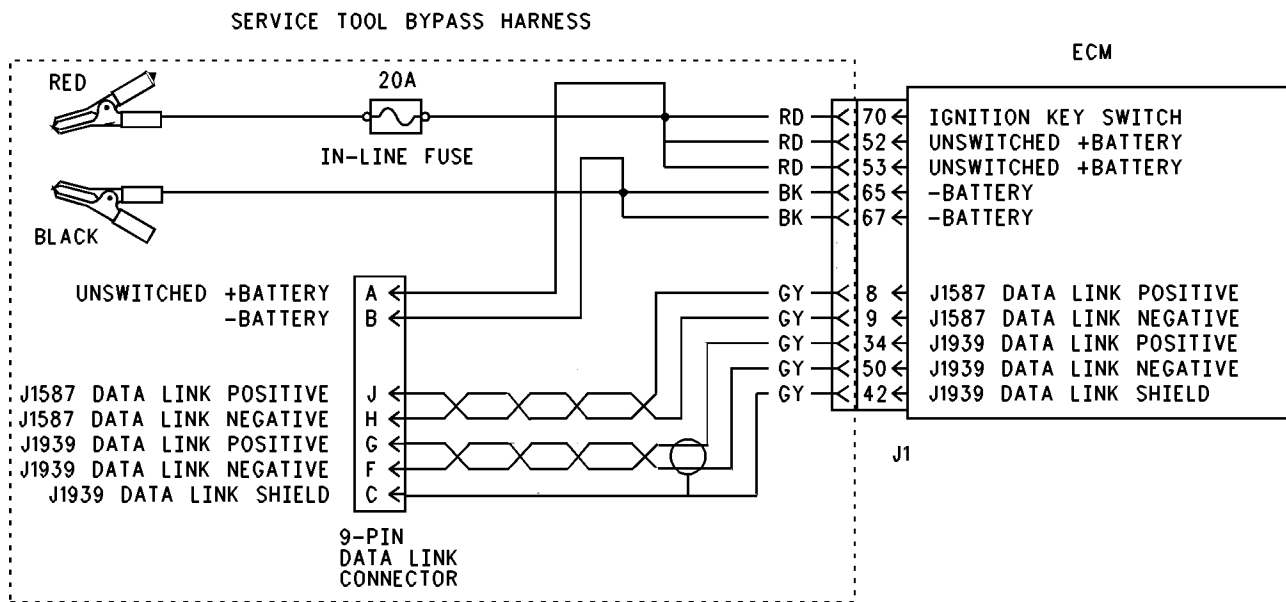

Illustration 40

g00741090

WARNING

Batteries give off flammable fumes which can explode.

To avoid injury or death, do not strike a match, cause a spark, or smoke in the vicinity of a battery.

NOTICE

Do Not connect the bypass harness to the battery until the 20 Amp in-line fuse has been removed from the +battery line. If the fuse is not removed before connection to the battery a spark may result.

- A. Turn the ignition key switch to the ON position.

- B.** Disconnect vehicle harness connector J1/P1 from the ECM.
- C.** Install an electronic service tool power bypass cable. Connect a bypass harness to ECM connector J1.

Refer to Illustration 40 for the bypass harness.

Note: This bypass directly connects the circuit for the ignition key switch to the ECM. The ECM will remain powered until the connection to the unswitched battery line “+” is disconnected. Remove the 20 Amp fuse from the in-line fuse holder to power down the ECM. Do Not connect the bypass to the battery posts without first removing the 20 Amp in-line fuse or do not remove the bypass from the battery posts without first removing the 20 Amp in-line fuse.

Expected Result:

ET is operating correctly.

Results:

- Yes

Repair: Perform the following repair:

There is a problem in the vehicle wiring, or another device in the vehicle is causing problems on the data link. Either determine the device that is causing the problem or send the vehicle to the OEM dealer for repair.

Verify that the repair eliminates the problem.

STOP.

- No – Verify that the 20 Amp fuse in the bypass harness of ET is not open. A fuse that is open is a blown fuse. Proceed to Test Step 7.

Test Step 7. Connect ET and the ECM to Another Battery.

 **WARNING**

Batteries give off flammable fumes which can explode.

To avoid injury or death, do not strike a match, cause a spark, or smoke in the vicinity of a battery.

NOTICE

Do Not connect the bypass harness to the battery until the 20 Amp in-line fuse has been removed from the +Battery line. If the fuse is not removed before connection to the battery a spark may result.

- A.** Connect the Battery wires from the bypass harness of ET to a different battery that is not on the vehicle.

Expected Result:

ET is operating correctly.

Results:

- Yes – The vehicle battery is causing the problem.

Repair: Perform the following diagnostic procedure:

Troubleshooting, “Ignition Key Switch Circuit and Battery Supply Circuit - Test”

STOP.

- No

Repair: Perform the following repair:

1. Temporarily connect a test ECM.
2. Remove all jumpers and replace all connectors.
3. Recheck the system for active diagnostic codes.
4. Repeat the test step.
5. If the problem is resolved with the test ECM, reconnect the suspect ECM.
6. If the problem returns with the suspect ECM, replace the ECM.
7. Verify that the repair eliminates the problem.

STOP.

i01614685

Change Oil Lamp Circuit - Test

SMCS Code: 1408-081; 7431-081

System Operation Description:

Use this procedure under the following situation:

Note: This feature is only available with OCT01 Software.

Use this procedure to determine if the change oil lamp (terminal 30 output 1) is operating properly.

Output 1 can operate as a change oil lamp or as a PTO Switch ON Lamp. The parameter “Change Oil Lamp” must be programmed to “J1/P1:30” to use output 1 as a change oil lamp. The change oil lamp illuminates when the engine oil needs to be changed.

The following parameters determine when the ECM will illuminate the change oil lamp.

- “Maintenance Indicator Mode”
- “PM1 Interval”
- “PM1 Engine Oil Capacity”

If “Maintenance Indicator Mode” is programmed to “Manual - Distance” or “Manual - Hours”, the parameter “PM1 Interval” must be programmed. If “Maintenance Indicator Mode” is programmed to “Automatic - Distance” or “Automatic - Hours”, the parameter “PM1 Engine Oil Capacity” must be programmed.

Electrical Connections of the Lamp

One terminal of the lamp must be connected to battery voltage through the vehicle wiring. The other terminal is connected to the ECM at the vehicle harness connector J1/P1 at terminal 30.

The ECM provides a path to ground that will turn on the lamp.

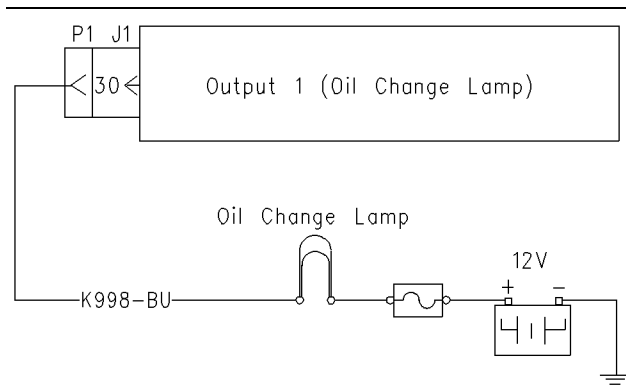

Illustration 41
Circuit schematic for the change oil lamp

Test Step 1. Inspect Electrical Connectors and Wiring.

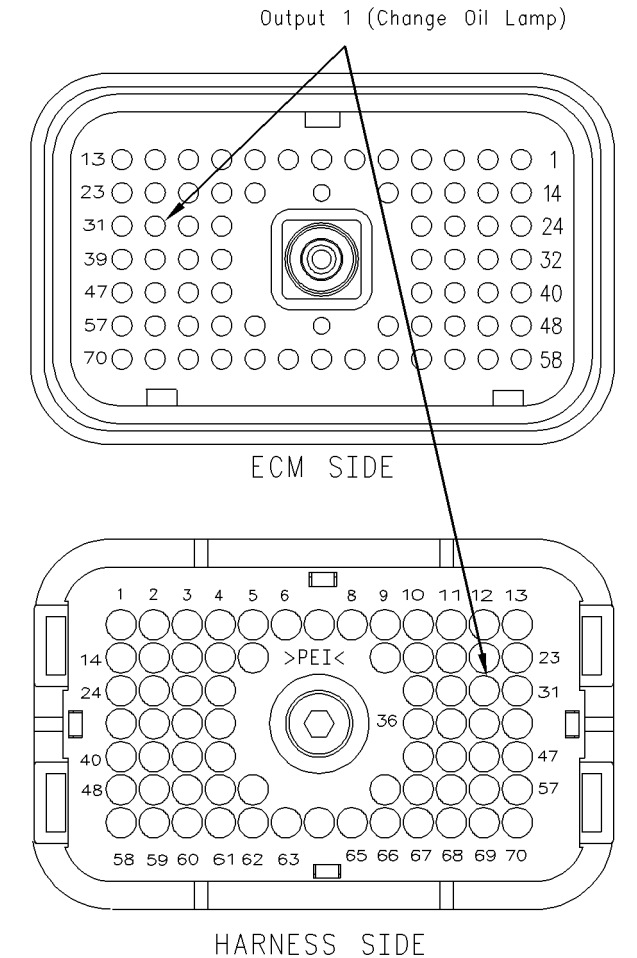

Illustration 42
P1 connector

- Thoroughly inspect ECM vehicle harness connector J1/P1, the firewall bulkhead connector, and the terminals for the change oil lamp.

Refer to Troubleshooting, “Electrical Connectors - Inspect” for details.
- Perform a 45 N (10 lb) pull test on each of the wires in the ECM connector that are associated with the change oil lamp.
- Check the ECM connector (allen head screw) for the proper torque of 6.0 N·m (55 lb in).
- Check the harness and wiring for abrasion and for pinch points from the sensor to the ECM.

Expected Result:

All connectors, pins, and sockets should be completely coupled and/or inserted and the harness and wiring should be free of corrosion, abrasion or pinch points.

Results:

- **OK** – Proceed to Test Step 2.
- **Not OK**

Repair: Repair the connectors or wiring and/or replace the connectors or wiring. Ensure that all of the seals are properly in place and ensure that the connectors are completely coupled.

Verify that the repair eliminates the problem.

STOP.

Test Step 2. Check for Normal Operation of the Change Oil Lamp.

- A.** Monitor the change oil lamp. Turn the ignition key switch to the ON position, while the engine is off. The lamp should turn on for five seconds. Then, the lamp should turn off.

Expected Result:

The change oil lamp turns on and the change oil lamp turns off per the description above.

Results:

- **Yes** – The change oil lamp is operating normally. **STOP.**
- **No** – The lamp does not turn on. Proceed to Test Step 3.

Test Step 3. Test the Change Oil Lamp Circuit.

Illustration 43

g00836182

P1 Connector

- A.** Turn the ignition key switch to the OFF position.
- B.** Fabricate a jumper wire 100 mm (4 inch) long. Crimp a Deutsch pin to both ends of the wires.
- C.** Disconnect vehicle harness connector P1 from the ECM.
- D.** Insert the jumper into terminal 30 of connector P1.
- E.** Connect the other end of the jumper wire to terminal 65 (–battery) of connector P1.
- F.** Turn the ignition key switch to the ON position.
- G.** While the lamp is being watched, insert the jumper wire and remove the jumper wire.

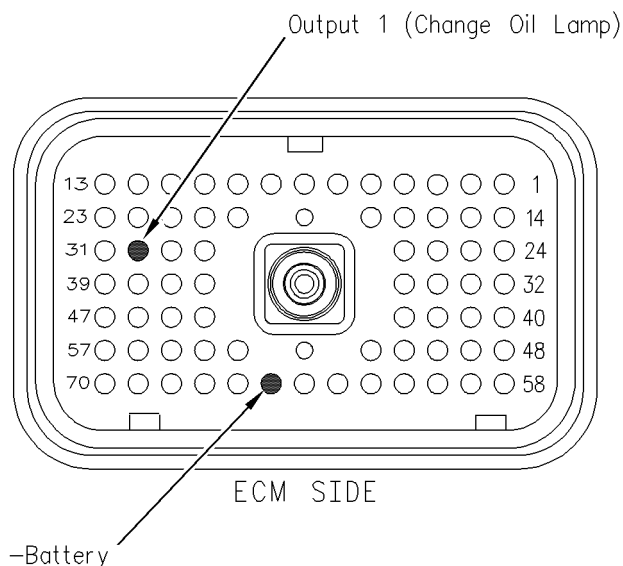
Expected Result:

Result 1 The change oil lamp turns on while the jumper is connected to both sockets. Also, the change oil lamp turns off when the jumper is removed from one of the sockets.

Result 2 The change oil lamp does not turn on while the jumper is connected to both sockets.

Result 3 The change oil lamp will stay on while the ECM vehicle harness connector is disconnected.

Results:

- **Result 1** – The change oil lamp is functioning properly. Proceed to Test Step 4.

- **Result 2** – The change oil lamp did not turn on. The vehicle’s lamp circuit is not functioning properly. The lamp is probably burned out or there is a problem in the wiring from the cab to either the ECM or the +battery connection. Repair the lamp circuit or send the vehicle to the OEM dealer for repairs. **STOP**.

• **Result 3**

Repair: Perform the following diagnostic procedure:

The circuit between the ECM and the lamp is shorted to chassis ground. Repair the circuit or send the vehicle to the OEM dealer for repairs.

STOP.

Test Step 4. Check the Output Circuit of the ECM.

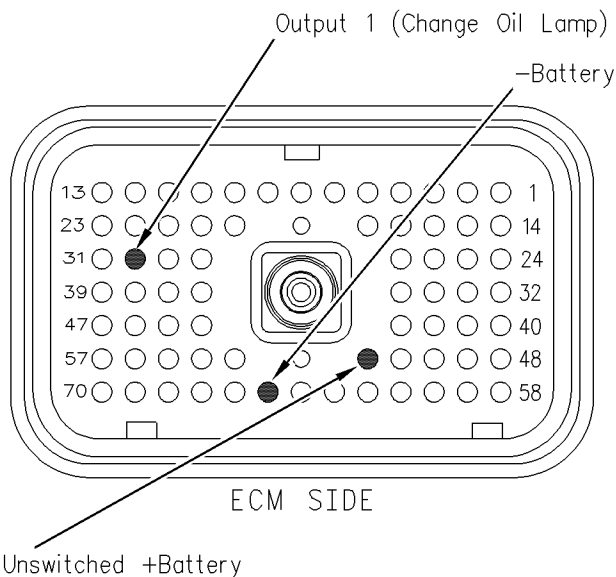

Illustration 44 g00836186
Breakout T

- Disconnect ECM vehicle harness connector J1/P1.
- Insert a 70-Terminal breakout T between ECM vehicle harness connector J1 and ECM vehicle harness connector P1.
- Connect one probe of the voltage test lamp to terminal 65 (-battery). Connect the other probe of the voltage test lamp to terminal 52 (unswitched +battery) of the breakout T.

- The test lamp should turn on. If the test lamp does not turn on, either the test lamp is faulty or the wiring to the ECM is faulty. Continue with this step if the lamp turns on.

- Leave the probe of the test lamp connected to terminal 52 (unswitched +battery).

- Connect the other probe of the test lamp to terminal 30 (Output 1) of the breakout T.

Refer to Illustration 44.

- Connect ET. Access the following display screens in order:

- Diagnostics
- Diagnostic Test
- Special Test

- Activate the “Change Oil Lamp” test. Observe the voltage test lamp. The lamp should turn on when the test is active. Also, the lamp should turn off when the test is inactive.

Expected Result:

The test lamp turns on and the test lamp turns off per the above description.

Results:

- **Yes** – The ECM is operating correctly. There is a problem in the vehicle wiring or the lamp. **STOP**.
- **No**

Repair: Temporarily connect a test ECM. Check the output circuit of the ECM that supplies power to the change oil lamp when the test ECM is installed. If the problem is resolved with the test ECM, reconnect the suspect ECM. If the problem returns with the suspect ECM, replace the ECM.

STOP.

i01631786

Check Engine Lamp Circuit - Test

SMCS Code: 7431-081

System Operation Description:

Use this procedure under the following situation:

Use the following information in order to determine if the check engine lamp is operating incorrectly:

The check engine lamp is the only standard lamp that is used.

The following background information is related to the following procedure:

Check Engine Lamp

The check engine lamp is used to provide the following functions:

- Indicate the existence of an active diagnostic code.
- Indicate driver alert status of the Idle Shutdown Timer.
- Read diagnostic flash codes.

Power Up Lamp Check

At powerup, the lamp will turn ON for five seconds. The lamp will continue to flash if there is an active diagnostic code.

Operation with an Active Diagnostic Code

While the engine is operating, the lamp will turn ON for a minimum of five seconds when certain fault conditions exist. If certain fault conditions exist, the lamp will operate in the following manner:

- The check engine lamp will turn ON for five seconds.
- The check engine lamp will turn OFF for a short time.
- The check engine lamp will turn ON for another five seconds.

The check engine lamp will continue to operate in this manner while the fault condition exists.

Indication of the Driver Alert Status of the Idle Shutdown Timer

During the final 90 seconds of the operation of the Idle Shutdown Timer, the check engine lamp will begin to flash. The flashing of the check engine lamp indicates that an engine shutdown is near.

Flashing Out Diagnostic Flash Codes

The flash codes are two-digit representations of diagnostic codes. The PID-FMI diagnostic code should be used for troubleshooting. The PID is the Parameter Identifier. The FMI is the Failure Mode Identifier. A 110-03 is an example of a PID-FMI Diagnostic Code. Flash codes provide an indication of a failure. Flash codes are not as specific as diagnostic codes. Flash codes only indicate that a failure has occurred. Flash codes do not indicate the specific type of failure. For example, the flash code (27) is used for a 110-03 fault code and a 110-04 fault code. Flash codes should not be used for troubleshooting.

Diagnostic flash codes that are active can be viewed at any time. Turn the Cruise Control On/Off switch to the OFF position. Hold the Set/Resume switch in either the SET position or the RESUME position until the lamp begins to flash. Then release the Set/Resume switch.

The flash code is determined by the blinking of the check engine lamp. The lamp will blink for the first digit of the flash code, and the lamp will pause for five seconds. Then, the lamp will blink for the second digit.

Some vehicles are equipped with a diagnostic enable switch. The diagnostic enable switch is used to flash the diagnostic codes by grounding the input of the diagnostic enable switch from terminal 46 (Input 7) to terminal 5 (sensor common).

Note: The check engine lamp should not continuously flash the diagnostic flash codes. If the set switch, the resume switch, or the diagnostic enable switch has not been used, then the circuit is probably shorted to ground.

Electrical Connection of the Check Engine Lamp

One terminal of the check engine lamp must be connected to battery voltage through the vehicle wiring. The other terminal is connected to the ECM at the vehicle harness connector J1/P1 terminal 28 (check engine lamp).

The ECM provides a path to ground in order to turn the lamp ON.

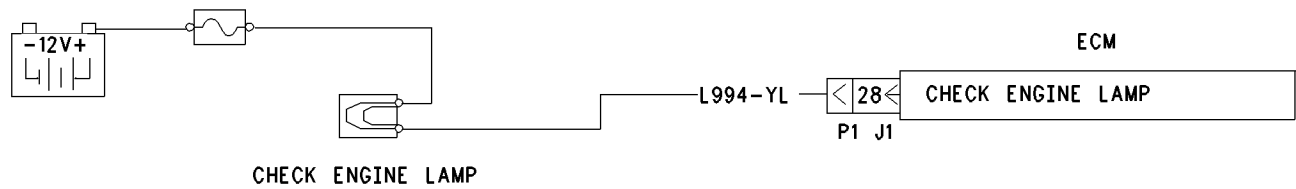

Illustration 45
Schematic for Lamp

g00676880

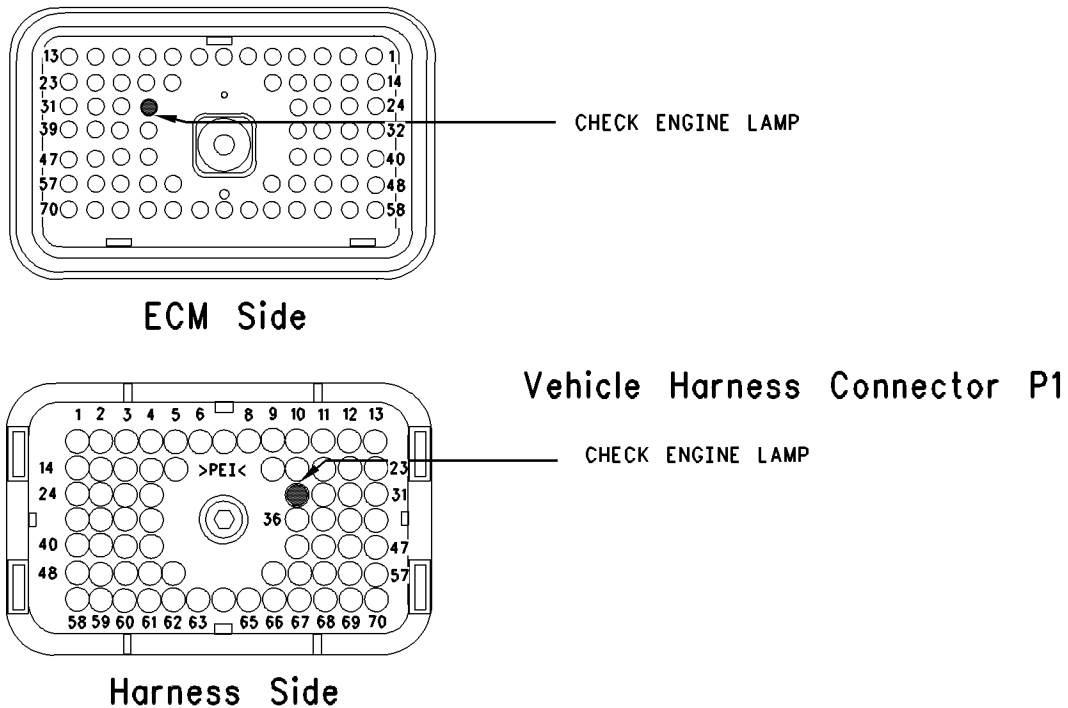

Illustration 46
Terminal locations for ECM

g00676965

Test Step 1. Inspect Electrical Connectors and Wiring.

- A.** Thoroughly inspect ECM vehicle harness connector J1/P1, the firewall bulkhead connector, and the check engine lamp (terminal 28). Refer to Troubleshooting, "Electrical Connectors - Inspect" for details.
- B.** Perform a 45 N (10 lb) pull test on each of the wires in the ECM connector that are associated with the check engine lamp.

Refer to Illustration 46.

- C.** Check the ECM connector (allen head screw) for the proper torque of 6.0 N·m (55 lb in).
- D.** Check the harness and wiring for abrasion and pinch points from the battery to the ECM.

Expected Result:

All connectors, pins and sockets should be completely coupled and/or inserted and the harness and wiring should be free of corrosion, abrasion or pinch points.

Results:

- OK – Proceed to test step 2.
- Not OK

Repair: Repair the connectors or wiring and/or replace the connectors or wiring. Ensure that all of the seals are properly in place and ensure that the connectors are completely coupled.

STOP.

Test Step 2. Check for Normal Operation of the Lamp.

A. Monitor the check engine lamp.

- a.** Turn the ignition key switch to the ON position. The lamp should illuminate for five seconds. Then, the lamp should turn off.
- b.** The lamp will continue flashing if there is an active diagnostic code. If there is an active diagnostic code, connect ET in order to read the active diagnostic code. Troubleshoot the problem.

Expected Result:

The check engine lamp turns on and the check engine lamp turns off per the above description.

Results:

- **Yes** – The check engine lamp appears to operating correctly at this time. **STOP.**
- **No** – Proceed to test step 3.

Test Step 3. Test the Lamp Circuit.

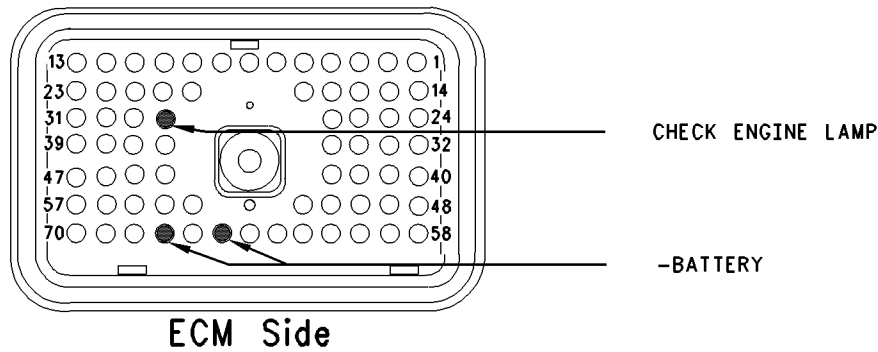

Illustration 47

g00676968

- A. Disconnect ECM vehicle harness connector J1/P1.
- B. Fabricate a jumper wire 100 mm (4 inch) long. Crimp a Deutsch Pin to both ends of the wire.
- C. Insert the jumper into the terminal 28 (check engine lamp) of connector P1.
- D. Connect the other side of the jumper wire to P1 terminal 65 (-battery).
- E. Turn the ignition key switch to the ON position.
- F. While the lamp is being watched, insert the jumper wire and remove the jumper wire.

Refer to Illustration 47.

Expected Result:

Result 1 The check engine lamp turns on while the jumper is connected to both sockets. Also, the check engine lamp turns off when the jumper is removed from one of the sockets.

Result 2 The check engine lamp does not turn on while the jumper is connected to both sockets.

Result 3 The lamp will stay on while the ECM vehicle harness connector is disconnected.

Results:

- **Result 1** – The check engine lamp circuit is functioning properly. Proceed to test step 4.

- **Result 2** – The lamp did not turn on. The vehicle's lamp circuit is not functioning properly. The lamp is probably burned out or there is a problem in the wiring from the cab to either the ECM or the +Battery connection. Repair the lamp circuit or send the vehicle to the OEM dealer for repairs. **STOP.**

- **Result 3**

Repair: Perform the following diagnostic procedure:

The circuit between the ECM and the lamp is shorted to chassis ground. Repair the circuit or send the vehicle to the OEM dealer for repairs.

STOP.

Test Step 4. Check ECM Operation of the Check Engine Lamp.

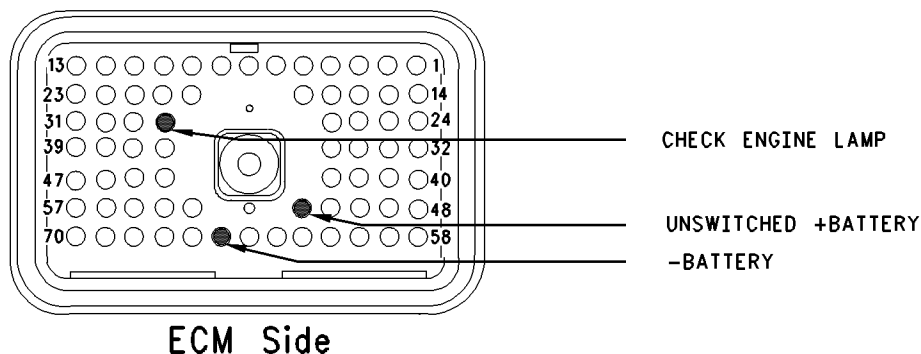

Illustration 48

g00642525

ECM Breakout T-connector

- A. Disconnect ECM vehicle harness connector J1/P1.
- B. Insert a breakout T between ECM vehicle harness connector J1 and ECM vehicle harness connector P1.
- C. Connect a probe for the voltage test lamp to terminal 65 (-battery) and connect the other probe to terminal 52 (unswitched +battery) of the breakout T.
- D. The test lamp should turn on. If the test lamp does not turn on, either the test lamp is faulty or the wiring to the ECM is faulty. Continue with this step if the lamp turns on.
- E. Leave the probe for the voltage test lamp connected to terminal 52 (unswitched +battery).
- F. Connect the other probe of the test lamp to terminal 28 (check engine lamp) of the breakout T.

Refer to Illustration 48.

- G. Watch the voltage test lamp. Turn the ignition key switch to the ON position.
- H. The lamp should turn on for five seconds. Then, the lamp should turn off. The lamp will continue flashing if there is an active diagnostic code. If there is an active diagnostic code, connect ET in order to read the active diagnostic code. Troubleshoot the problem.

Expected Result:

The check engine lamp turns on and the check engine lamp turns off per the above description.

Results:

- **Yes** – The ECM is operating correctly. There is a problem in the vehicle wiring or the lamp. Repair the vehicle wiring or the lamp, as required. **STOP**.
- **No** – Temporarily connect a test ECM. Check the operation of the check engine lamp when the test ECM is installed. If the problem is resolved with the test ECM, then reconnect the suspect ECM. If the problem returns with the suspect ECM, then replace the ECM. **STOP**.

i01857608

Clutch Pedal Position Switch Circuit - Test

SMCS Code: 1900-081-ZS

System Operation Description:

Use this procedure under the following situation:

Use this procedure to determine if the clutch pedal position switch is preventing normal operation of cruise control, fast idle, idle set speed, or PTO operation:

The following switch circuits can also prevent the correct operation of the cruise control, idle set speed or PTO operation:

- service brake pedal position (switch 1)
- service brake pedal position (switch 2)
- neutral switch
- cruise control set/resume switch
- cruise control on/off switch

- PTO on/off switch
- cruise control pause switch

The switches are described in the respective circuit tests in Troubleshooting.

All of the following Customer Programmable Parameters can affect cruise control, fast idle, idle set speed, and PTO operation:

- “Low Cruise Control Speed Set Limit”
- “High Cruise Control Speed Set Limit”
- “Idle Vehicle Speed Limit”
- “Fast Idle RPM #1”
- “Fast Idle RPM #2”
- “Cruise/Idle/PTO Switch Configuration”
- “Idle/PTO Bump rpm”
- “Idle/PTO rpm Ramp Rate”
- “PTO Vehicle Speed Limit”
- “Cruise Pause Switch”

The vehicle speed calibration can also affect the cruise control, the idle set speed, and the PTO if the vehicle speed calibration is incorrectly programmed. Refer to Troubleshooting, “Customer Specified Parameters”.

Clutch Switch

The clutch pedal position switch is normally closed when the pedal is released. Depressing the clutch pedal should open the circuit. This switch is OEM supplied. The clutch pedal position switch is typically a limit switch that is mounted near the pedal. The clutch pedal position switch is usually adjustable.

This switch may not be connected to an input on the ECM. The parameter “Clutch Pedal Position Switch” determines the input to the ECM. If the parameter is programmed to J1/P1:22 a switch must be connected to terminal 22. If the parameter is programmed to one of the J1939 options, the switch position will be transmitted to the ECM over the J1939 data link. If a problem is suspected with the J1939 data link, refer to Troubleshooting, “Powertrain Data Link Circuit - Test”.

The following background information is related to this procedure:

The kickout switch refers to the switch that is used to exit the cruise control, the fast idle, the PTO, or the idle set speed.

The operation of the Caterpillar electronic engine cruise control is similar to the operation of the cruise controls that are installed in automobiles. The operation of fast idle, idle and PTO are similar to the operation of cruise except that the idle and the PTO govern engine rpm instead of vehicle speed.

Note: Idle in this procedure is an engine idle rpm above the programmed low idle rpm. Idle is set by using the cruise control on/off switch and the set/resume switch. Refer to Troubleshooting, “PTO Switch Circuit - Test” for additional information regarding the programmable options for the Dedicated PTO.

Note: Fast idle in this procedure is an engine idle rpm above the programmed low idle rpm. Fast idle is set by using a dedicated fast idle switch.

Cruise Control On/Off Switch

This switch must be on before cruise control or controlled idle can be activated. This switch is on when the switch is closed. When the switch is closed the following terminals are connected:

- ECM connector J1/P1 terminal 59 (cruise control on/off switch)
- Terminal 5 (AP sensor/switch sensor common)

Note: If the vehicle is programmed to use the “Dedicated PTO”, the PTO on/off switch overrides the cruise control on/off switch. The PTO on/off switch overrides the cruise control on/off switch when the vehicle speed is within the range of the “PTO Vehicle Speed Limit” that is programmed.

Set/Resume Switch

With the cruise control on/off switch in the ON position and the vehicle speed within the range of the programmed “Low Cruise Control Speed Set Limit” and the “High Cruise Control Speed Set Limit”, momentarily pressing the set switch will activate cruise control, and the ECM will maintain the current speed.

After a speed has been set and the speed is then disengaged by using the brake, the clutch, the cruise control pause switch, or the on/off switch, the ECM will seek the previous set speed when the resume switch is toggled. This assumes that the vehicle speed is above the “Low Cruise Control Speed Set Limit” for cruise control or the vehicle speed is below the “Idle/PTO Vehicle Speed Limit” for the idle and the PTO.

After a speed has been set, pressing and holding the set/resume switch in position will cause the engine to establish a new set speed. The system's reaction depends on the programming of the "Cruise/Idle/PTO Switch Configuration".

When the set/resume switch is momentarily pressed, the cruise set point will change one mph. The rate of change is dependent on the programmed "Idle/PTO Bump rpm" when the engine is setting on idle speed.

Cruise Control Pause Switch

The cruise control pause switch is not a switch that is wired to an input. The switch position is broadcast over a J1939 data link. The parameter "Cruise Pause Switch" must be programmed to use a cruise control pause switch. After a speed has been set and the speed is then disengaged by using the cruise control pause switch, the ECM will seek the previous set speed when the resume switch is toggled. This assumes that the vehicle speed is above the "Low Cruise Control Speed Set Limit" for cruise control or the vehicle speed is below the "Idle/PTO Vehicle Speed Limit" for the idle and the PTO.

Kickout Switches

The brake pedal position switches, the neutral switch, the cruise control pause switch, and the clutch pedal position switch are used in the cruise control mode, the PTO mode, the fast idle mode, and the idle mode to discontinue cruise operation, PTO operation, fast idle operation, or idle operation. The capability to override the idle shutdown timer is determined by the "Allow Idle Shutdown Override" parameter setting. The "Allow Idle Shutdown Override" is a Customer Parameter.

Usage of Transmission Style Switches

The "Transmission Style" parameter determines the switches that will be used. The following switches can be used.

- clutch pedal position
- neutral
- service brake pedal position (switch 1)
- service brake pedal position (switch 2)

Refer to Table 144 for additional information.

Table 144

Setting For Transmission Style Parameter	Switch Usage.			
	Service Brake Switch 1	Service Brake Switch 2	Clutch	Neutral
"Manual Option 1"	X		X	
"Manual Option 2"	X	X	X	
"Automatic Option 1"	X			
"Automatic Option 2"	X	X		
"Automatic Option 3"	X	X		X
"Automatic Option 4"	X			X
"AT/MT/HT Option 1"	X			
"AT/MT/HT Option 2"	X	X		
"AT/MT/HT Option 3"	X	X		X
"AT/MT/HT Option 4"	X			X
"Universal Option"	X		X	X

If the "Transmission Style" parameter is programmed to one of the following options, the input for the clutch pedal position switch is not used:

- "Automatic Options 1"
- "Automatic Option 2"
- "Automatic Option 3"
- "Automatic Option 4"
- "AT/MT/HT Option 1"
- "AT/MT/HT Option 2"
- "AT/MT/HT Option 3"
- "AT/MT/HT Option 4"

A service brake pedal position (switch 1) is required for all configurations. The service brake pedal position (switch 1) connects to the ECM through connector P1 terminal 45. The service brake pedal position (switch 2) connects to the ECM through connector P1 terminal 64. The clutch pedal position switch connects to the ECM through connector P1 terminal 22. The neutral switch connects to the ECM through connector P1 terminal 62.

Some engines that were built before JULY 1999 may have a Basic ECM. The Basic ECM was used only on General Motors chassis. Other chassis used engines that were built with a Full Feature ECM. Basic ECM software does not have the parameter for "Transmission Style". For these systems, a jumper wire must be installed between the clutch switch input and the sensor common when an automatic transmission is installed. When the jumper wire is installed, the "Clutch Switch" status will always indicate "OFF". Engines that were built after JULY 1999 use only one type of ECM that can be configured for "Basic" or "Full Feature" operation. A new parameter was added in order to provide this flexibility. The "Truck Manufacturer" parameter was added in order to allow the configuration of the "GM Basic" operation or the "Other Full Feature" operation. This parameter is programmed at Caterpillar when the engine is built. The parameter for "Transmission Style" is not available for engines that have software that is dated prior to SEP00 and the parameter for "Truck Manufacturer" is programmed to "GM". SEP00 and newer engines that are programmed to "GM" use the "Transmission Style" parameter. The factory default for the "GM" setting is the "Universal" option. The "Universal" option provides identical features as the "Basic" system that is described above. If the "Transmission Style" parameter is programmed to the "Universal" option, a jumper wire must be installed between the clutch switch input and the sensor common when an automatic transmission is installed. Otherwise, the "Transmission Style" parameter can be programmed to match the specific arrangement of the vehicle.

If the problem is with undetermined Cruise/Idle/PTO kickouts use the following procedure:

Operate the vehicle in Cruise/Idle/PTO mode.

After the kickout, review the status screen on an electronic service tool. The status screen for the parameter indicates the cause of the kickout. This must be performed before the ignition key switch is turned off. It is important to remember that the parameter will only indicate the last kickout since the ECM has been powered by the ignition key switch.

The following kickout status parameters are available:

- "Cruise Kickout"
- "Idle Kickout"
- "PTO Kickout"
- "Fast Idle Kickout"

This parameter is blank when the ECM is first powered up. If this parameter is blank, "No Occurrence" is indicated. This parameter remains blank until the ECM detects the use of the cruise/idle/PTO mode. Also, this parameter remains blank until the ECM detects the disengagement of the cruise/idle/PTO mode. Refer to Tables 145 and 146 in order to interpret the status screen kickout status parameter.

Table 145

Cruise Control Kickout Status Table		
Electronic Service Tool	Meaning or Possible Cause	Troubleshooting
“Vehicle Speed >=Limit”	Intermittent vehicle speed signal or lost vehicle speed signal.	Refer to Troubleshooting, “Vehicle Speed Circuit - Test”.
“Switch Turned Off”	The cruise/idle on/off switch is turned off or the switch circuit has an open circuit condition.	Refer to Troubleshooting, “Cruise Control Switch Circuit - Test”.
“Cruise Control PAUSE Switch”	The cruise control pause switch is depressed or there is an illegal message on the J1939 data link.	Refer to Troubleshooting, “Powertrain Data Link Circuit - Test”.
“Brake Pedal Depressed”	The service brake pedal is depressed or the service brake switch circuit has an open circuit condition.	Refer to Troubleshooting, “Service Brake Pedal Position (Switch 1) Circuit - Test”.
“ClutchPedal Depressed”	The clutch pedal is depressed or the clutch pedal switch circuit has an open circuit condition. Also, the switch could be incorrectly adjusted.	Proceed with the test procedure.
“Neutral”	The transmission is not in gear or the transmission switch circuit has a short circuit condition.	Refer to Troubleshooting, “Neutral Switch Circuit - Test”.
“Bad Vehicle Speed”	Vehicle speed signal is erratic or intermittent.	Refer to Troubleshooting, “Vehicle Speed Circuit - Test” if a problem with the signal exists.
“PTO Switch On”	The PTO on/off switch is turned on or the circuit for the PTO on/off switch has a short circuit condition.	Refer to Troubleshooting, “PTO Switch Circuit - Test”.
Set Switch Timeout	The set/resume switch was held in the SET position for more than 15 seconds (Basic) or there is a short circuit in the switch circuit.	Cruise control cannot be set until the cruise control on/off switch is turned to the OFF position and then turned back to the ON position. If the circuit for the set switch is suspected, proceed with this test procedure.
Resume Switch Timeout	The set/resume switch was held in the SET position for more than 15 seconds (Basic) or there is a short circuit in the switch circuit.	Cruise control cannot be set until the cruise control on/off switch is turned to the OFF position and then turned back to the ON position. If the circuit for the resume switch is suspected, proceed with this test procedure.
“No Occurrence” or “Not Kicked Out”	Cruise control has not been enabled since the ECM has been powered up.	Drive the vehicle in cruise in order to create the problem again.

Table 146

Idle Kickout Status Table		
ET	Meaning or Possible Cause	Troubleshooting
“No Engine Speed”	Intermittent engine speed signal or lost engine speed signal.	Refer to Troubleshooting, “Engine Speed/Timing Circuit - Test”.
“Switch Turned Off”	The cruise/idle on/off switch is turned off or the switch circuit has an open circuit condition.	Refer to Troubleshooting, “Cruise Control Switch Circuit - Test”.
“Cruise Control PAUSE Switch”	The cruise control pause switch is depressed or there is an illegal message on the J1939 data link.	Refer to Troubleshooting, “Powertrain Data Link Circuit - Test”.
“Brake Pedal Depressed”	The service brake pedal is depressed or the service brake switch circuit has an open circuit condition.	Refer to Troubleshooting, “Service Brake Pedal Position (Switch 1) Circuit - Test”.
“Clutch Pedal Depressed”	The clutch pedal is depressed or the clutch pedal switch circuit has an open circuit condition. Also, the switch could be incorrectly adjusted.	Proceed with the test procedure.
“Vehicle Speed \geq Limit”	The vehicle speed has exceeded the Idle Vehicle Speed Limit or the vehicle speed signal is erratic or intermittent.	Refer to Troubleshooting, “Vehicle Speed Circuit - Test” if a problem with the signal exists.
“Neutral”	The transmission is not in neutral or the transmission neutral switch circuit has an open circuit condition.	Refer to Troubleshooting, “Neutral Switch Circuit - Test”.
“PTO Switch On”	The PTO on/off switch is turned on or the circuit for the PTO on/off switch has a short circuit condition.	Refer to Troubleshooting, “PTO Switch Circuit - Test”.
“No Occurrence” or “Not Kicked Out”	Idle set speed has not been enabled since the ECM has been powered up.	Operate the vehicle in the Idle mode in order to create the problem again.

Table 147

Fast Idle Kickout Status Table		
Electronic Service Tool	Meaning or Possible Cause	Troubleshooting
“No Engine Speed”	Intermittent engine speed signal or lost engine speed signal.	Refer to Troubleshooting, “Engine Speed/Timing Circuit - Test”.
“Switch Turned Off”	The fast idle on/off switch is turned off or the switch circuit has an open circuit condition.	Refer to Troubleshooting, “Cruise Control Switch Circuit - Test”.
“Cruise Control PAUSE Switch”	The cruise control pause switch is depressed or there is an illegal message on the J1939 data link.	Refer to Troubleshooting, “Powertrain Data Link Circuit - Test”.
“Brake Pedal Depressed”	The service brake pedal is depressed or the service brake switch circuit has an open circuit condition.	Refer to Troubleshooting, “Service Brake Pedal Position (Switch 1) Circuit - Test”.
“Clutch Pedal Depressed”	The clutch pedal is depressed or the clutch pedal switch circuit has an open circuit condition. Also, the switch could be incorrectly adjusted.	Proceed with the test procedure.
“Vehicle Speed ≥ Limit”	The vehicle speed has exceeded the Idle Vehicle Speed Limit or the vehicle speed signal is erratic or intermittent.	Refer to Troubleshooting, “Vehicle Speed Circuit - Test” if a problem with the signal exists.
“Neutral”	The transmission is not in neutral or the transmission neutral switch circuit has an open circuit condition.	Refer to Troubleshooting, “Neutral Switch Circuit - Test”.
“No Occurrence” or “Not Kicked Out”	Fast idle set speed has not been exited since the ECM has been powered up.	Operate the vehicle in the Idle mode in order to create the problem again.

Table 148

Table For The PTO Kickout Status Screen On The Electronic Service Tool		
Electronic Service Tool	Meaning or Possible Cause	Troubleshooting
No Engine Speed	Intermittent engine speed signal or lost engine speed signal.	Refer to Troubleshooting, "Speed/Timing Circuit - Test".
Switch Turned Off	The PTO On/Off switch is turned OFF or the switch circuit has an open circuit condition.	Refer to Troubleshooting, "Cruise Control Switch Circuit - Test".
"Cruise Control PAUSE Switch"	The cruise control pause switch is depressed or there is an illegal message on the J1939 data link.	Refer to Troubleshooting, "Powertrain Data Link Circuit - Test".
"Brake Pedal Depressed"	The service brake pedal is depressed or the service brake switch circuit has an open circuit condition.	Refer to Troubleshooting, "Service Brake Pedal Position Switch 1 Circuit - Test".
"Clutch Pedal Depressed"	The clutch pedal is depressed or the clutch pedal switch circuit has an open circuit condition. Also, the switch could be incorrectly adjusted.	Proceed with the test procedure.
Vehicle Speed ≥ Limit	The vehicle speed has exceeded the PTO Vehicle Speed Limit or the vehicle speed signal is erratic or intermittent.	Refer to Troubleshooting, "Vehicle Speed Circuit - Test" if a problem with the signal exists.
Neutral	The transmission is not in neutral or the transmission neutral switch circuit has an open circuit condition.	Refer to Troubleshooting, "Neutral Switch Circuit - Test".
"No Occurrence" or "Not Kicked Out"	The PTO has not been enabled since the ECM has been powered up.	Operate the vehicle in the PTO mode in order to create the problem again.

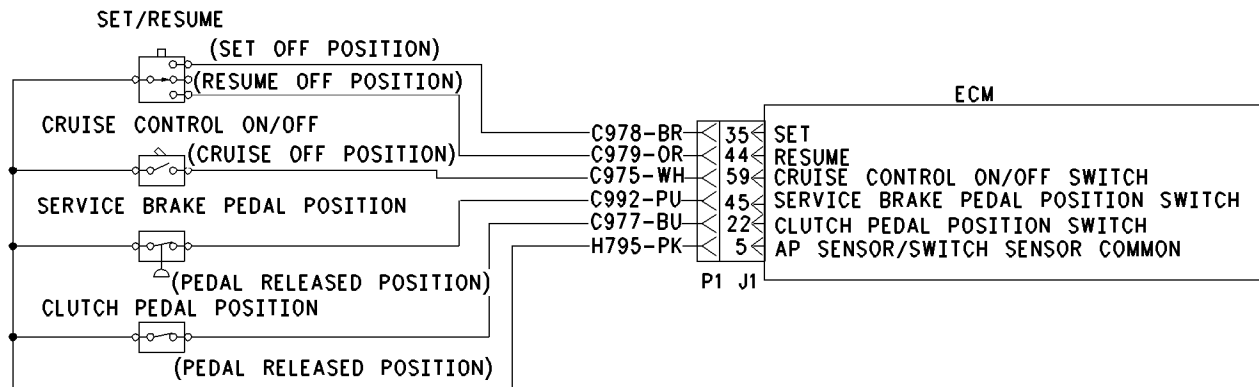

Illustration 49

g00643881

Schematic for cruise control switch, service brake pedal position switch 1 and clutch pedal position switch

Test Step 1. Determine the Type of Problem.

- A. Connect the electronic service tool.
- B. Turn the ignition key switch to the ON position.

- C. If the vehicle will not allow setting a cruise speed, an idle speed or a PTO speed, check the following Customer Parameters:

Cruise Control Parameters

- “Low Cruise Control Speed Set Limit”
- “High Cruise Control Speed Set Limit”

Idle Parameters

- “Fast Idle RPM #1”
- “Fast Idle RPM #2”
- “Idle Vehicle Speed Limit”
- “Idle RPM Limit”
- “Top Engine Limit” (TEL)

PTO Parameters

- “PTO Configuration”
- “PTO Kickout Vehicle Speed Limit”

D. Ensure that the vehicle is not experiencing a problem due to one of these parameters. Refer to Troubleshooting, “Customer Specified Parameters” for a description of the parameters, if necessary.

E. Check the status screen that indicates the last cause of a kickout for one of the following modes:

- Cruise Kickout
- Idle Kickout
- Fast Idle Kickout
- PTO Kickout

Refer to Tables 145, 146, 147, and 148 for the meaning of the status screen.

Expected Result:

The problem is due to a parameter setting or the problem is due to a normal kickout.

Results:

- **Yes** – Explain the proper operation of system to the driver. **STOP.**
- **No**

Repair: Refer to Tables 145, 146, 147, and 148 for recommended troubleshooting.

If a problem is still suspected with the clutch switch circuit perform the following procedure:

Proceed to Test Step 2.

Test Step 2. Inspect Electrical Connectors and Wiring.

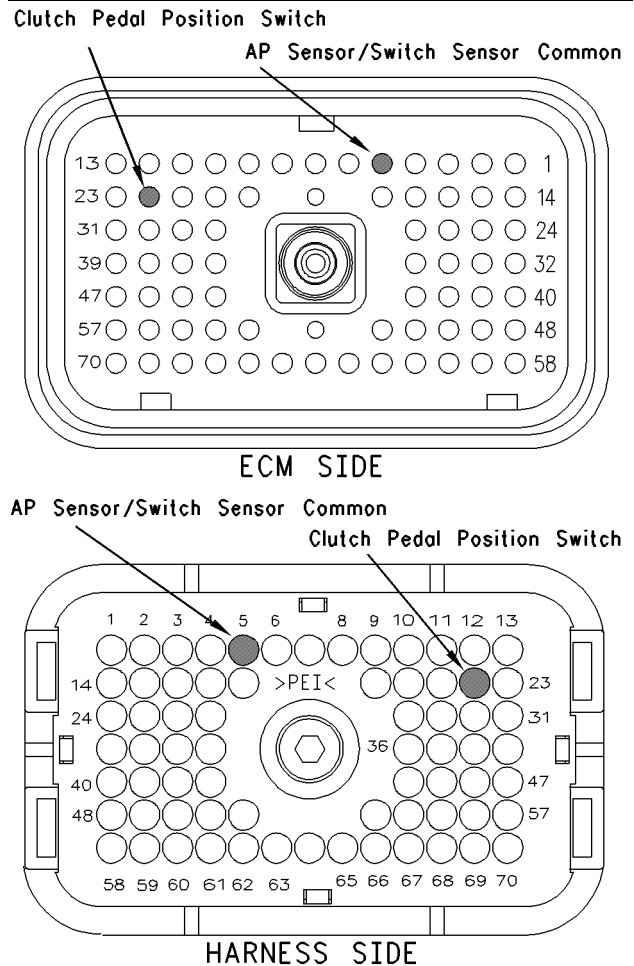

Illustration 50

g00773080

A. Thoroughly inspect ECM vehicle harness connector J1/P1, the firewall bulkhead connector and the terminals for the following switches in the connectors:

- clutch pedal position switch (terminal 22)
- AP sensor/switch sensor common (terminal 5)

Refer to Troubleshooting, “ Electrical Connectors - Inspect” for details.

B. Perform a 45 N (10 lb) pull test on each of the wires in the ECM connector that are associated with the switches.

Refer to Illustration 50.

C. Check the ECM connector (allen head screw) for the proper torque of 6.0 N·m (55 lb in).

D. Check the harness and wiring for abrasion and pinch points from the sensor to the ECM.

Expected Result:

All connectors, pins and sockets should be completely coupled and/or inserted and the harness and wiring should be free of corrosion, abrasion or pinch points.

Results:

- **OK** – Proceed to Test Step 3.
- **Not OK**

Repair: Repair the connectors or wiring and/or replace the connectors or wiring. Ensure that all of the seals are properly in place and ensure that the connectors are completely coupled.

Verify that the repair eliminates the problem.

STOP.

Test Step 3. Check Clutch Switch Status on the Electronic Service Tool.

Table 149

Clutch Pedal Position Status Table		
Switch Position or Pedal Position	Status	Circuit
The Clutch Pedal is DEPRESSED.	ON	Open
The Clutch Pedal is RELEASED.	OFF	Closed

- A.** Access the status screen on the electronic service tool.
- B.** Turn the ignition key switch to the ON position.
- C.** Depress the clutch pedal while the status of the clutch pedal position switch is being observed. Also, release the clutch pedal while the status of the clutch pedal position switch is being observed.

Expected Result:

The switch status changes per the information in Table 149.

Results:

- **Yes** – The switch is operating normally. **STOP.**
- **Intermittent Problem Suspected** – Proceed to Test Step 4.
- **No** – The ECM is not reading the switch status change. Proceed to Test Step 5.

Test Step 4. Operate the Vehicle and Check the Kickout Status Parameter.

- A.** For an intermittent Cruise Control Kickout, talk to the driver in order to determine the conditions when the kickout occurs. Topics of examination could be the following examples:

- specific speed
- road conditions
- weather conditions

Take the vehicle for a road test in order to duplicate these conditions and set the cruise control. Operate the vehicle in cruise control until the problem reoccurs.

- B.** For an intermittent idle kickout, talk to the driver in order to determine the conditions when the kickout occurs. A topic of examination could be the following example:

- specific engine rpm

Start the engine. Duplicate these conditions and set the idle rpm. Operate the vehicle in idle until the problem reoccurs.

Note: The status screen will only indicate the last kickout. The status screen will lose this information if the ignition key switch is turned off.

- C.** Connect the electronic service tool and check the status screen for the last cause of the kickout. Refer to Tables 145 and 146 for an explanation of the status parameter.
- D.** If the status screen is blank, then either there was no kickout of the cruise control, or the power to the ECM was turned off before the information could be read. Repeat this test step.

Note: A status screen that is blank indicates “No Occurrence” or “Not Kicked Out”.

Expected Result:

RESULT 1 The status screen displays the following result:

- “Clutch Pedal Depressed”

RESULT 2 The status screen displays the following result:

- “Switch Turned Off”

RESULT 3 The status screen displays the following result:

- “Cruise Control PAUSE Switch”

RESULT 4 The status screen displays the following result:

- “Brake Pedal Depressed”

RESULT 5 The status screen displays the following result:

- “Vehicle Speed < Limit”
- “Bad Vehicle Speed”
- “Vehicle Speed ≥ Limit”

RESULT 6 The status screen displays the following result:

- “PTO Switch ON”

RESULT 7 The status screen displays the following result:

- “Neutral”

RESULT 8 The status screen displays the following result:

- “No Engine Speed”

RESULT 9 The status screen displays the following result:

- “Set Switch Timeout”
- “Resume Switch Timeout”

Results:

- **Result 1** – Proceed to Test Step 5.
- **Result 2**

Repair: Perform the following diagnostic procedure:

Troubleshooting, “Cruise Control Switch Circuit - Test”

STOP.

- **Result 3**

Repair: Perform the following diagnostic procedure:

Troubleshooting, “Powertrain Data Link Circuit - Test”

STOP.

- **Result 4**

Repair: Perform the following diagnostic procedure:

Troubleshooting, “Service Brake Pedal Position (Switch 1) Circuit - Test”

STOP.

- **Result 5**

Repair: Perform the following diagnostic procedure:

Troubleshooting, “Vehicle Speed and Speedometer Circuit - Test”

STOP.

- **Result 6**

Repair: Perform the following diagnostic procedure:

Troubleshooting, “PTO Switch Circuit - Test”

STOP.

- **Result 7**

Repair: Perform the following diagnostic procedure:

Troubleshooting, “Neutral Switch Circuit - Test”

STOP.

- **Result 8**

Repair: Perform the following diagnostic procedure:

Troubleshooting, “Engine Speed/Timing Sensor Circuit - Test”

STOP.

- **Result 9**

Repair: Perform the following diagnostic procedure:

Troubleshooting, “Cruise Control Switch Circuit - Test”

STOP.

Test Step 5. Check the Switch Circuit for the ECM.

Table 150

Clutch Switch Input Status Table		
Condition of Switch Circuit	Switch Status	Circuit
Terminal 22 is Open.	ON	Open
Terminal 22 connected to terminal 5.	OFF	Closed

- A. Turn the ignition key switch to the OFF position.
- B. Fabricate a jumper wire 100 mm (4 inch) long. Crimp a Deutsch pin to both ends of the wires.
- C. Disconnect vehicle harness connector P1 from the ECM.
- D. Connect a 70-Termial breakout T to ECM connector J1 and connect P1 to the breakout T.
- E. Install the jumper into terminal 22 (clutch pedal position switch) of the breakout T. Connect the other end of the jumper to terminal 5 AP sensor/switch sensor common of the ECM connector P1 of the breakout T.
- F. Turn the ignition key switch to the ON position.
- G. Connect the electronic service tool to the cab data link connector.
- H. Access the status screen.
- I. While the clutch switch status is being monitored on the status screen slowly remove the jumper from terminal 5 AP sensor/switch sensor common. Now, slowly insert the jumper into terminal 5 AP sensor/switch sensor common.

Refer to Table 150.

Expected Result:

The switch status changes per the information in Table 150.

Results:

- **Yes** – The ECM is functioning properly. Proceed to Test Step 6.
- **No** – The ECM is NOT functioning properly.

Repair: Perform the following repair:

1. Temporarily connect a test ECM.

2. Remove all jumpers and replace all connectors.
3. Recheck the system for active diagnostic codes.
4. Repeat the test step.
5. If the problem is resolved with the test ECM, reconnect the suspect ECM.
6. If the problem returns with the suspect ECM, replace the ECM.
7. Verify that the repair eliminates the problem.

STOP.

Test Step 6. Insert A Jumper At The Clutch Switch.

Table 151

Clutch Switch Input Status Table		
Condition of Switch Circuit	Switch Status	Circuit
Clutch Pedal Position Switch Wires are Disconnected.	ON	Open
Clutch Pedal Position Switch Wires are Connected.	OFF	Closed

- A. Turn the ignition key switch to the OFF position.
- B. Ensure that ECM vehicle harness connector J1/P1 is connected.
- C. Find the clutch switch in the vehicle.
- D. Disconnect the wires from the clutch switch terminals.
- E. Turn the ignition key switch to the ON position.
- F. Connect the electronic service tool to the cab data link connector.
- G. Access the status screen.
- H. While the switch status is being monitored on the status screen slowly connect the switch wires and slowly disconnect the switch wires.

Refer to Table 151.

Expected Result:

The switch status changes per the information in Table 151.

Results:

- Yes

Repair: Perform the following repair:

Replace the faulty switch.

Verify that the repair eliminates the problem.

STOP.

- No – There is a problem in the harness between the switch and the ECM. Proceed to Test Step 7.

Test Step 7. Insert a Jumper at the Bulkhead Connector.

Table 152

Clutch Switch Input Status Table		
Condition of Switch Circuit	Switch Status	Circuit
Bulkhead Wires are Disconnected.	ON	Open
Bulkhead Wires are Connected.	OFF	Closed

- A. Turn the ignition key switch to the OFF position.
- B. Fabricate a jumper wire 100 mm (4 inch) long. Crimp a Deutsch pin to each end of the wires.
- C. Find the terminal for the clutch switch. Also, find the terminal for the sensor common for the AP sensor/switch. Look for the terminals in the engine side of the bulkhead connector for the vehicle harness.
- D. Insert the jumper wire between the two terminals in the engine side of the bulkhead connector.
- E. Turn the ignition key switch to the ON position.
- F. Connect the electronic service tool to the cab data link connector.
- G. Access the status screen.
- H. While the switch status is being monitored on the status screen alternately remove the jumper wire between the two terminals, and alternately insert the jumper wire between the two terminals.

Refer to Table 152.

Expected Result:

The switch status changes per the information in Table 152.

Results:

- Yes – The problem is in the vehicle wiring between the bulkhead connector and the switch.

Repair: Perform the following repair:

Inspect the vehicle wiring and repair the vehicle wiring, as required. If the problem still exists with the wiring, send the vehicle to the OEM dealer.

STOP.

- No – The problem is in the vehicle wiring between the bulkhead connector and the ECM.

Repair: Perform the following repair:

Inspect the vehicle wiring and repair the vehicle wiring, as required. If the problem still exists with the wiring, send the vehicle to the OEM dealer.

STOP.

i01683692

Coolant Level Sensor Circuit - Test

SMCS Code: 7422-081

System Operation Description:

Use this procedure under the following situation:

Use this procedure if any of the following diagnostic codes are active or easily repeatable:

- 111-02 Coolant Level Sensor Fault (12)
- 111-03 Coolant Level Sensor Open Circuit (12)
- 111-04 Coolant Level Sensor Short Circuit (12)

Do not use this procedure for either of the following diagnostic codes:

- 111-01 Low Coolant Level Warning (62)
- 111-11 Very Low Coolant Level (62)

These diagnostic codes indicate a low coolant level but not an electrical system malfunction. Refer to Troubleshooting, “111-01 Low Coolant Level Warning” or Troubleshooting, “111-11 Very Low Coolant Level” for the proper troubleshooting procedure.

The following background information is related to this procedure:

The coolant level sensor is an OEM installed component for the vehicle. This sensor is an optional sensor for "Engine Monitoring". "Engine Monitoring" is a programmable feature of the Caterpillar ECM. The sensor is selectable through a Customer Programmable Parameter and the Customer Programmable Parameter may be protected by Customer Passwords. Some OEM installed coolant level sensors are not connected to the Engine Control Module (ECM). Do not confuse an OEM installed coolant level sensor that is independent of "Engine Monitoring" with the coolant level sensor that is used for "Engine Monitoring".

The customer programmable parameter for the coolant level sensor can be programmed to "4-Pin", "2-pin switch", or "2-wire float sensor". Also, the customer programmable parameter for the coolant level sensor can be programmed to "NO" if the option for the coolant level sensor is not being used.

If the parameter "Coolant Level Sensor" is programmed to "NO", the coolant level sensor is ignored by the ECM. Conversely, if the parameter is set, then a sensor must be installed. The "Engine Monitoring" is set when the "Engine Monitoring" is programmed to "WARNING", "DERATE", or "SHUTDOWN". The coolant level is monitored by the Engine Monitoring System when the parameter "Coolant Level Sensor" is programmed to "4-Pin" or "2-wire float sensor".

4-Pin Sensor

The sensor indicates the presence or the absence of coolant at the sensor probe. A sensor with a 4-pin connector that requires a +5 VDC connection to a power supply must be used. The sensor is powered from the ECM through the ECM vehicle harness connector J1/P1 terminal 2 (+5 VDC). The ECM vehicle harness connector has 70 terminals. The signal wires for the coolant level sensor are connected at J1/P1:54 (coolant level low) and at J1/P1:49 (coolant level normal). The common wire for the sensor is connected to the ECM vehicle harness connector J1/P1 through terminal 5 (AP sensor/switch sensor common).

If coolant is present at the sensor probe, J1/P1:54 (coolant level low) has an output of near 0 VDC. If coolant is present at the sensor probe, J1/P1:49 (coolant level normal) has an output near +5 VDC. If coolant is not present at the sensor probe, J1/P1:54 (coolant level low) has an output of near +5 VDC. If coolant is not present at the sensor probe, J1/P1:49 (coolant level normal) has an output of near 0 VDC.

Note: If the coolant level sensor is programmed to "NO", the coolant level sensor is ignored by the ECM. Conversely, if the parameter is set, then a sensor must be installed. The "Engine Monitoring" is set when the "Engine Monitoring" is programmed to "WARNING", "DERATE", or "SHUTDOWN". The "Coolant Level Sensor" is set when the coolant level sensor is programmed to "4-Pin". If both parameters are set and a sensor is not installed, 111-02 Coolant Level Sensor Fault (12) will be logged.

2-Wire Float Sensor

Applications that program the parameter "Manufacturer/Model" to "Other" have the option of using a 2-wire float sensor to monitor the coolant level. To use a 2-wire float sensor, the parameter "Manufacturer/Model" must be programmed to "Other" and the parameter "Coolant Level Sensor" must be programmed to "2-wire float sensor". The sensor is connected to P1/J1:26 (sensor input) and to P1/J1:5 (AP sensor/switch sensor common). The sensor will provide information to the ECM at P1/J1:26 that will enable the ECM to determine if the coolant level is normal, low, or extremely low.

The "Engine Monitoring" is set when the "Engine Monitoring" is programmed to "WARNING", "DERATE", or "SHUTDOWN". The "Coolant Level Sensor" is set when the coolant level sensor is programmed to "2-wire float sensor". If both parameters are set and a sensor is not installed, 111-02 Coolant Level Sensor Fault (12) will be logged.

2-Pin Switch

Note: Do not use this procedure to troubleshoot the 2-pin switch coolant level switch. Refer to Troubleshooting, "111-01 Low Coolant Level Warning" or Troubleshooting, "111-11 Very Low Coolant Level" for the proper troubleshooting procedure.

Test Step 1. Use Cat ET to Check for an Active Coolant Level Sensor Fault

- A. Connect Caterpillar Electronic Technician (Cat ET) to the cab data link connector.
- B. Turn the ignition key switch to the ON position.
- C. Access the active diagnostic screen on Cat ET.
- D. Verify that one of the following diagnostic codes is active:
 - 111-02 Coolant Level Sensor Fault (12)
 - 111-03 Coolant Level Sensor Open Circuit (12)

- 111-04 Coolant Level Sensor Short Circuit (12)

Expected Result:

Result 1 111-02 Coolant Level Sensor Fault is active. This fault indicates that a problem exists with the 4-pin sensor or the 2-wire float sensor. Ensure that the vehicle is equipped with a 4-pin sensor.

Result 2 111-02 Coolant Level Sensor Fault is active. This fault indicates that a problem exists with the 4-pin sensor or the 2-wire float sensor. 111-03 Coolant Level Sensor Open Circuit or 111-04 Coolant Level Sensor Short Circuit is active. These faults indicate that a problem exists with the 2-wire float sensor. Ensure that the vehicle is equipped with a 2-wire float sensor.

Result 3 111-01 Low Coolant Level Warning is active or a 111-11 Very Low Coolant Level is active.

Results:

- Result 1 – Proceed to Test Step 2.
- Result 2 – Proceed to Test Step 8.
- Result 3

Repair: Refer to Troubleshooting, “111-01 Low Coolant Level Warning” or Troubleshooting, “111-11 Very Low Coolant Level” for the proper troubleshooting procedure.

STOP.

Test Step 2. Inspect Electrical Connectors and Wiring for the 4-Pin Sensor

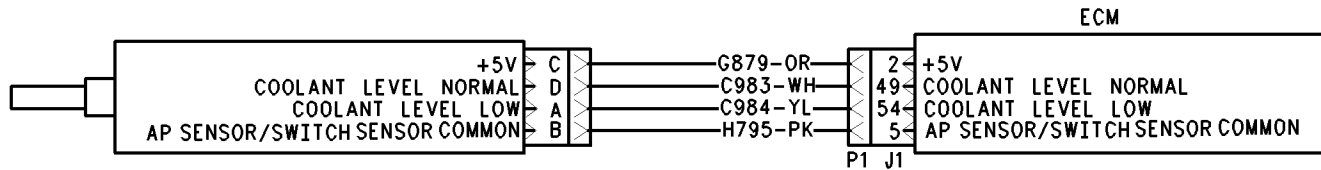

Illustration 51
Schematic for 4-pin sensor

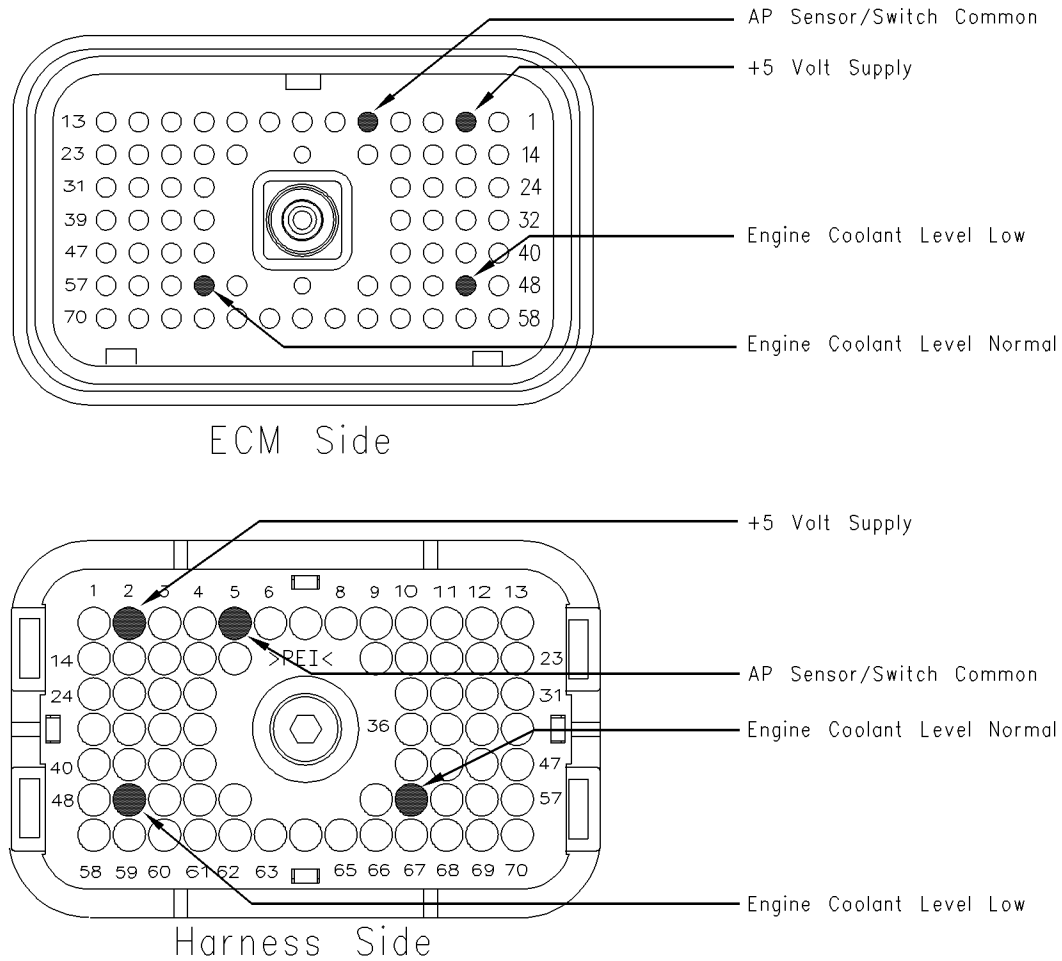

Illustration 52

g00845671

Terminal locations for ECM connector P1 (4-pin sensor)

- A.** Thoroughly inspect ECM vehicle harness connector J1/P1, the connector for the extension harness for the coolant level and the terminals for the coolant level sensor in the connectors. The connector for the extension harness for the coolant level connects the coolant level sensor to the vehicle harness in the engine compartment of some chassis. Refer to Troubleshooting, "Electrical Connectors - Inspect" for details.
- B.** Perform a 45 N (10 lb) pull test on each of the wires in the ECM connector that are associated with the following connections:
- P1/J1:2 +5V supply
 - P1/J1:5 AP sensor/switch sensor common
 - P1/J1:49 coolant level normal
 - P1/J1:54 coolant level low

Refer to Illustration 52.

- C.** Check the ECM connector (allen head screw) for the proper torque of 6.0 N·m (55 lb in).
- D.** Check the harness and wiring for abrasion and pinch points from the sensor to the ECM.

Expected Result:

All connectors, pins and sockets should be completely coupled and/or inserted and the harness and wiring should be free of corrosion, abrasion or pinch points.

Results:

- OK – Proceed to Test Step 3.
- Not OK

Repair: Repair the connectors or wiring and/or replace the connectors or wiring. Ensure that all of the seals are properly in place and ensure that the connectors are completely coupled.

Verify that the repair eliminates the problem. Clear all diagnostic codes.

STOP.

Test Step 3. Disconnect the Coolant Level Sensor and Check the Supply Voltage (+5 VDC)

- A. Turn the ignition key switch to the OFF position.
- B. Disconnect the coolant level sensor from the harness.
- C. Use a multimeter to measure the voltage at the harness connector from terminal C (+ 5 VDC) to terminal B (AP sensor/switch sensor common).
- D. Turn the ignition key switch to the ON position.

Expected Result:

The measured voltage is between 4.5 VDC and 5.5 VDC.

Results:

- Yes – Proceed to Test Step 4.
- No – Proceed to Test Step 5.

Test Step 4. Disconnect the Coolant Level Sensor and Check the Coolant Level Harness

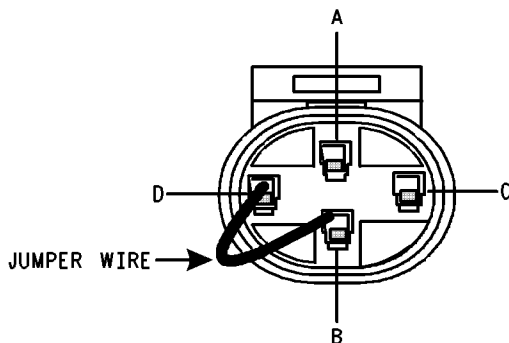

Illustration 53
Jumper wire
g00651005

- A. Turn the ignition key switch to the OFF position.
- B. Disconnect the coolant level sensor from the harness.
- C. Use a jumper wire in order to connect terminal D (coolant level normal) to terminal B (AP sensor/switch sensor common) at the harness connector.

Refer to Illustration 53.

- D. Turn the ignition key switch to the ON position.
- E. While the jumper wire is in place, access the status screen that indicates the coolant level status.
- F. Wait for 30 seconds. Read the status and record the status.
- G. Turn the ignition key switch to the OFF position.

Expected Result:

The coolant level status indicates “LOW” with the jumper in place.

Results:

- Yes – Leave the jumper wire in place. If a breakout T is installed, leave the breakout T in place also. Proceed to Test Step 6.
- No – Proceed to Test Step 7.

Test Step 5. Disconnect the Terminal for the Sensor Supply (+5 VDC) from the ECM Connector

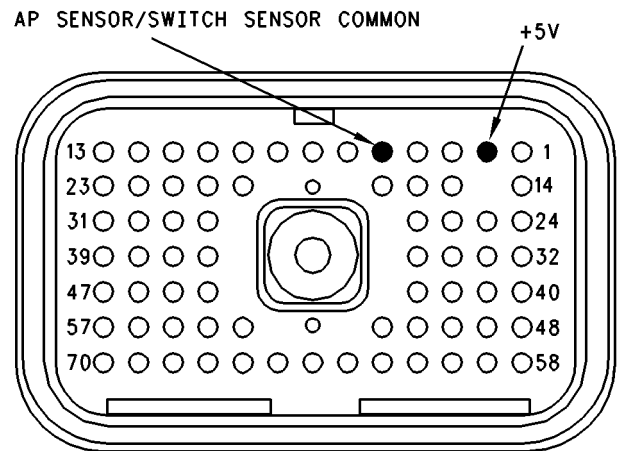

Illustration 54
Pin locations for the 4-pin sensor on the breakout T
g00756042

- A. Turn the ignition key switch to the OFF position.
- B. Disconnect the ECM vehicle harness connector J1/P1.
- C. Install a breakout T between ECM vehicle harness connector J1 and vehicle harness connector P1.
- D. Turn the ignition key switch to the ON position.

- E. Measure the voltage at the breakout T from terminal 2 to terminal 5.

Refer to Illustration 59.

Expected Result:

The measured voltage is between 4.5 VDC and 5.5 VDC.

Results:

- **Yes** – The problem is located in the harness wiring.

Repair: Repair the wiring or replace the wiring, as required.

Verify that the repair eliminates the problem.

STOP.

- **No** – The problem is on the ECM side.

Repair: Temporarily connect a test ECM. Ensure that the “Engine Monitoring” and the “Coolant Level Sensor” are programmed to match the old ECM. Check the test ECM by measuring the voltage at the breakout T from terminal 2 to terminal 5 again. If the problem is resolved with the test ECM, reconnect the suspect ECM. If the problem returns with the suspect ECM, replace the ECM.

STOP.

Test Step 6. Check the Wire Harness for the Coolant Level Low

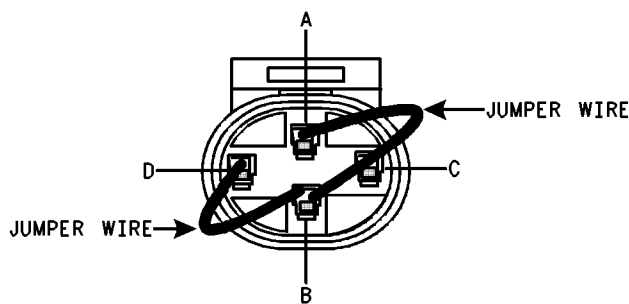

Illustration 55
Jumper wire

g00651008

- B. Use a jumper wire in order to connect terminal A (coolant level low) and terminal D (coolant level normal) to terminal B (sensor common) at the harness connector.

Refer to Illustration 55.

- C. Turn the ignition key switch to the ON position.
- D. While the jumper wires are in place, access the active diagnostic code screen on Cat ET.
- E. Verify that 111-02 Coolant Level Sensor Fault (12) is active.

Note: Wait for 30 seconds for the activation of the diagnostic code.

Expected Result:

111-02 Coolant Level Sensor Fault (12) is active while the jumper wires are in place.

Results:

- **Yes** – The harness and the ECM are working correctly.

Repair: Remove the jumpers. Replace the sensor and ensure that 111-02 Coolant Level Sensor Fault (12) disappears with the new sensor.

Verify that the repair eliminates the problem. Clear all diagnostic codes.

STOP.

- **No** – Proceed to Test Step 7.

- A. Turn the ignition key switch to the OFF position.

Test Step 7. Use a Breakout T to Check the ECM

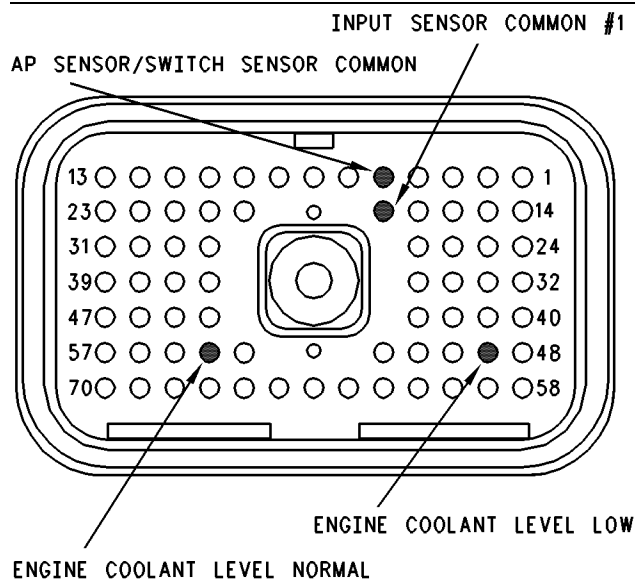

Illustration 56

g00756043

Pin locations for 4-pin sensor on the breakout T

- A.** Disconnect the ECM vehicle harness connector J1/P1.
- B.** Connect a breakout T to ECM connector J1 and connect P1 to the breakout T.
- C.** Fabricate two jumper wires 100 mm (4 inch) long. Crimp a Deutsch pin to both ends of each wire.
- D.** Turn the ignition key switch to the ON position.
- E.** Observe the Coolant Level Sensor Status on Cat ET. Install the jumper into the breakout T in order to connect terminal 49 (coolant level normal) to terminal 5 (AP sensor/switch sensor common).
- F.** Monitor the Coolant Level Sensor Status while the jumper is being inserted and removed. Wait for 30 seconds between the insertion of the jumper and the removal of the jumper. Waiting for 30 seconds allows the ECM to acknowledge the change. While the jumper remains in place, 111-01 Low Coolant Level Warning (62) should be active.
- G.** Record the result.
- H.** Leave the jumper installed in the breakout T.
- I.** While the active diagnostic code screen is being monitored, connect another jumper from terminal 54 (coolant level low) to terminal 18 (input sensor common 1) of the breakout T.
- J.** While both jumper wires are in place, access the active diagnostic code screen on Cat ET. Verify that 111-02 Coolant Level Sensor Fault (12) is active.
- Wait for 30 seconds for the activation of the diagnostic code.
- Refer to Illustration 56.

Expected Result:

The Coolant Level Sensor Status behaves in the following manner:

- The Coolant Level Sensor Status indicates “OK” before the jumper wire is installed between terminal 49 and terminal 5. 111-02 Coolant Level Sensor Fault (12) may be active.
- The Coolant Level Sensor Status changes to “LOW” after the jumper wire is installed between terminal 49 and terminal 5. Also, the diagnostic code 111-01 (Low Coolant Level Warning) is active.

111-02 Coolant Level Sensor Fault (12) is active when both jumper wires are installed.

Results:

- **Yes** – The ECM is functioning properly.

Repair: Repair the harness or replace the harness, as required.

Verify that the repair eliminates the problem. Clear all diagnostic codes.

STOP.

- **No**

Repair: Temporarily connect a test ECM. Ensure that the “Engine Monitoring” and the “Coolant Level Sensor” are programmed to match the old ECM. Recheck the test ECM by using the breakout T and the same procedure that was used previously. If the problem is resolved with the test ECM, reconnect the suspect ECM. If the problem returns with the suspect ECM, replace the ECM.

STOP.

Test Step 8. Inspect Electrical Connectors and Wiring for the 2-Wire Float Sensor

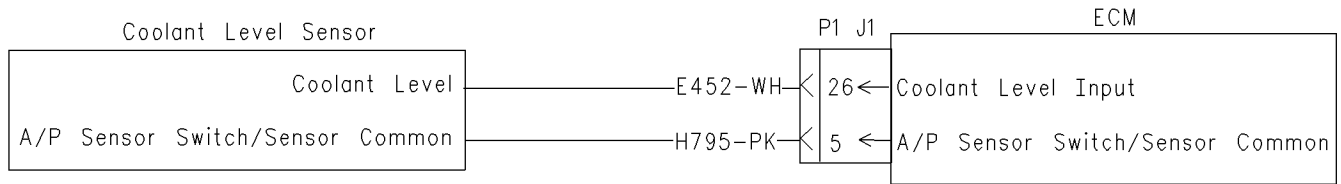

Illustration 57

g00882602

Schematic for 2-wire float sensor

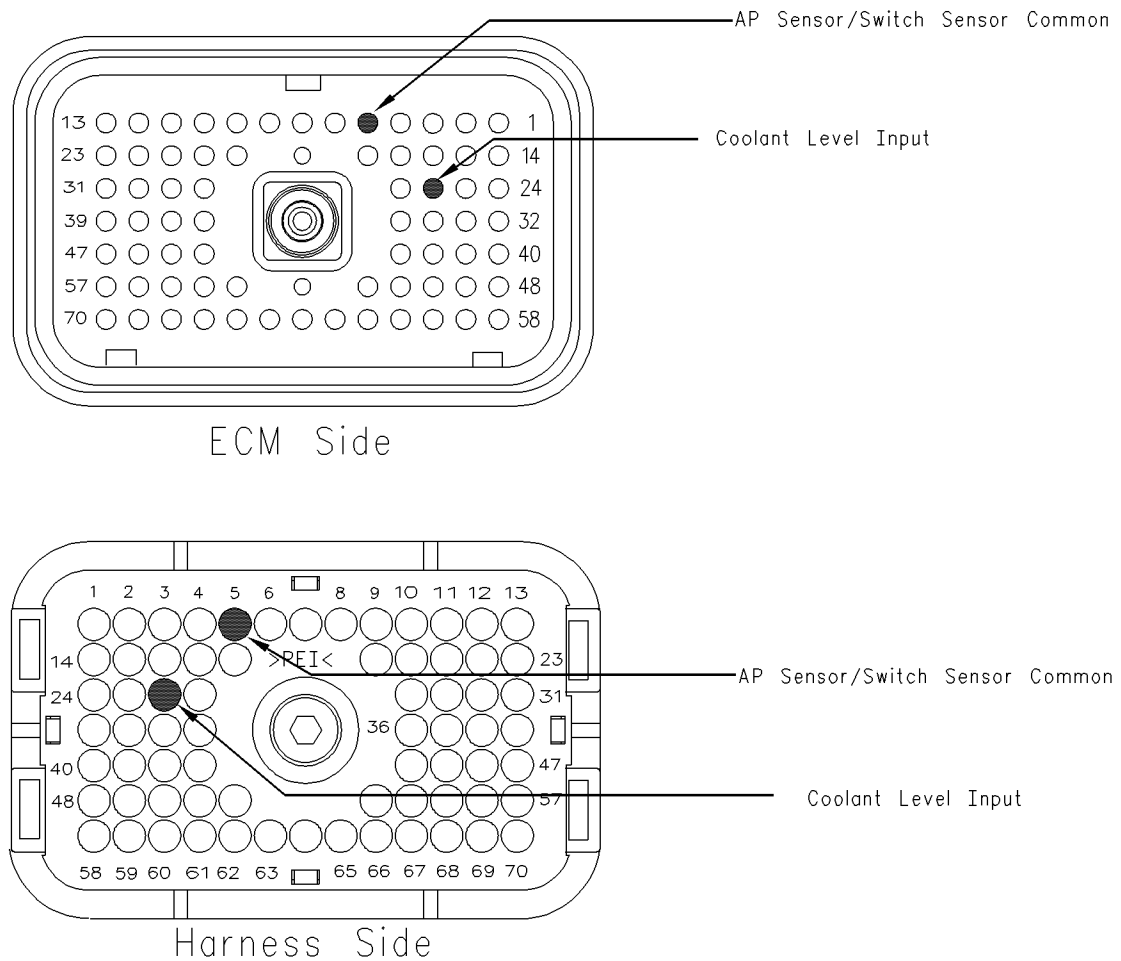

Illustration 58

g00884766

Terminal locations for ECM connector P1 (2-wire float sensor)

- A.** Thoroughly inspect ECM vehicle harness connector J1/P1, the connector for the coolant level sensor and the terminals for the coolant level sensor in the connectors. Refer to Troubleshooting, "Electrical Connectors - Inspect" for details.
- B.** Perform a 45 N (10 lb) pull test on each of the wires in the ECM connector that are associated with the following connections:

- P1/J1:26 coolant level input
- P1/J1:5 AP sensor/switch sensor common

Refer to Illustration 58.

- C.** Check the ECM connector (allen head screw) for the proper torque of 6.0 N·m (55 lb in).
- D.** Check the harness and wiring for abrasion and pinch points from the sensor to the ECM.

Expected Result:

All connectors, pins and sockets should be completely coupled and/or inserted and the harness and wiring should be free of corrosion, abrasion or pinch points.

Results:

- **OK** – Proceed to Test Step 9.
- **Not OK**

Repair: Repair the connectors or wiring and/or replace the connectors or wiring. Ensure that all of the seals are properly in place and ensure that the connectors are completely coupled.

Verify that the repair eliminates the problem. Clear all diagnostic codes.

STOP.

Test Step 9. Disconnect the Coolant Level Sensor and Check the Supply Voltage (+5 VDC)

- A.** Turn the ignition key switch to the OFF position.
- B.** Disconnect the coolant level sensor from the harness.
- C.** Use a multimeter to measure the voltage at the harness connector.
- D.** Turn the ignition key switch to the ON position.

Expected Result:

The measured voltage is between 4.5 VDC and 5.5 VDC.

Results:

- **Yes** – The correct voltage is reaching the sensor.
Repair: Replace the sensor.
STOP.
- **No** – Proceed to Test Step 10.

Test Step 10. Disconnect the Terminal for the Sensor Supply (+5 VDC) from the ECM Connector

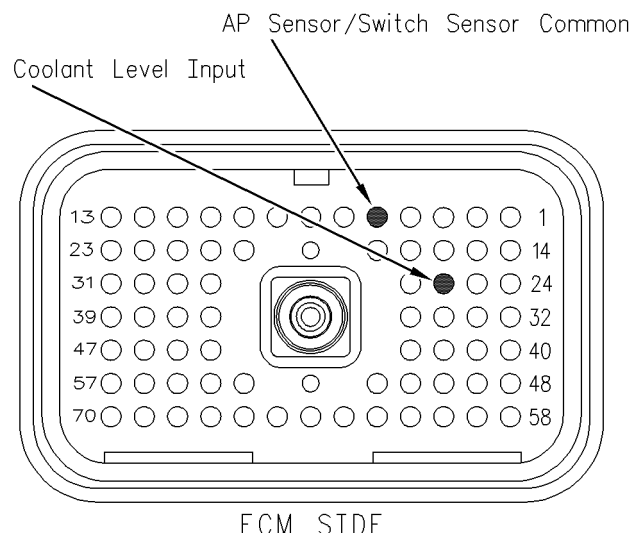

Illustration 59 g00884813
Terminal locations on the breakout T (2-wire float sensor)

- A.** Turn the ignition key switch to the OFF position.
- B.** Disconnect the ECM vehicle harness connector J1/P1.
- C.** Install a breakout T between ECM vehicle harness connector J1 and vehicle harness connector P1.
- D.** Turn the ignition key switch to the ON position.
- E.** Measure the voltage at the breakout T from terminal 26 to terminal 5.

Refer to Illustration 59.

Expected Result:

The measured voltage is between 4.5 VDC and 5.5 VDC.

Results:

- **Yes** – The problem is located in the harness wiring.
Repair: Repair the wiring or replace the wiring, as required.
Verify that the repair eliminates the problem.
STOP.
- **No** – The problem is on the ECM side.

Repair: Temporarily connect a test ECM. Ensure that the “Engine Monitoring” and the “Coolant Level Sensor” are programmed to match the old ECM. Check the test ECM by measuring the voltage at the breakout T from terminal 26 to terminal 5 again. If the problem is resolved with the test ECM, reconnect the suspect ECM. If the problem returns with the suspect ECM, replace the ECM.

STOP.

i01857652

Cooling Fan Circuit and A/C Compressor Clutch Circuit - Test

SMCS Code: 1359-081-ZS; 1408-081; 1802-081-ZS

System Operation Description:

Use this procedure under the following situation:

Use this procedure to determine if the circuit for the A/C compressor clutch is operating correctly. This circuit can be connected to J1/P1:41 Input #11 or to J1/P1:62 Input #12.

Note: Not all vehicle manufacturers, or all trucks for a manufacturer use the Caterpillar cooling fan circuit. Prior to troubleshooting, determine if the vehicle is using the ECM cooling fan circuit.

Check the following items in order to determine if a vehicle is using the ECM cooling fan circuit:

- The “Fan Control Type” parameter must be programmed to “On/Off” or one of the variable speed options. The Caterpillar factory default is None.
- “A/C Fan On Time” is programmed between one second and 600 seconds.
- A wire is present in the ECM vehicle harness connector J1/P1 (terminal 11) which is Output #5 (cooling fan solenoid).
- Perform the special test for the “On/Off Cooling Fan”. Access each menu in the order that follows: “Diagnostics”, “Diagnostic Tests”, and “Special Test”. Activating and then deactivating the circuit should cause the solenoid to click if the circuit is working properly.

The following background information is related to this procedure:

Cooling Fan

The signal for the cooling fan is provided by the ECM in order to control the cooling fan. An input from one of the following items may cause the fan to turn ON:

- A/C compressor clutch
- Engine coolant temperature sensor
- Air inlet temperature sensor
- Exhaust brake
- PTO on/off switch
- OEM installed A/C high pressure switch
- Manual fan override switch

The output for the cooling fan is intended to connect directly to the circuit for the cooling fan solenoid. Program the “Fan Control Type” parameter to “ON/OFF”. The fan will be off when the ECM output is ON (energized). When the ECM activates the fan, the fan will remain on for a minimum of 30 seconds except for the following conditions:

- Engine start-up
- The “A/C Pressure Switch Fan On Time” is programmed to less than 30 seconds.

During engine start-up, the ECM will keep the fan on for two seconds after the engine has reached the programmed low idle (700 to 800 rpm). The fan will be on continuously if the electrical circuit to the cooling fan solenoid has an open circuit or if the circuit for the ECM cooling fan relay has an open circuit.

Cooling Fan ON Conditions

The ECM will turn on the cooling fan under any of the following circumstances if engine speed is less than 2750 rpm:

- The engine is not running.
- Engine cranking
- The coolant temperature is greater than 96 °C (205 °F).
- Active diagnostic code for the coolant temperature sensor
- The inlet manifold air temperature is greater than 87 °C (189 °F).

- The inlet manifold air temperature is greater than 72 °C (162 °F) while the boost pressure is greater than 70 kPa (10 psi).
- The manual fan override switch is on.
- The “Fan with Exhaust Brake ON” is programmed to “YES” and the exhaust brake has been on at least two seconds.
- The “A/C Switch Fan On-Time” is programmed to a value above 0 and the A/C high pressure switch is open.
- The ECM is counting after the A/C high pressure switch has closed.
- The “PTO Activates Cooling Fan” parameter is programmed to “Continuous” and the PTO on/off switch is on.
- The “A/C Fan Request Switch” is programmed to “J1/P1:41” or “J1/P1:62” and the A/C compressor clutch is activated.

The last five items in the previous list are dependent upon the programming of the Customer Parameters.

Note: The ECM will turn off the cooling fan for 10 seconds during engine shutdown.

Cooling Fan Off Conditions

The cooling fan will be turned off by the ECM if engine rpm exceeds 2800 rpm or when all the following circumstances are met:

- The coolant temperature is less than 92 °C (198 °F).
- The fan has been on for at least 30 seconds.
- The inlet manifold air temperature is less than 53 °C (127 °F).
- The strategy for the exhaust brake is not active and the “Fan with Exhaust Brake ON” parameter is programmed to “YES”.
- The A/C high pressure switch is not active.
- The PTO on/off switch is in the OFF position and the “PTO Activates Cooling Fan” parameter is programmed to “Continuous”.
- The A/C compressor clutch is not active.
- The manual fan override switch is off.

The Cooling Fan Control can be Operated Independently of the ECM.

Operation of the cooling fan control can be controlled independently of the ECM. The OEM installed air conditioning high pressure switch may be used for independent cooling fan control. A cab mounted override switch in the solenoid circuit can also operate the cooling fan.

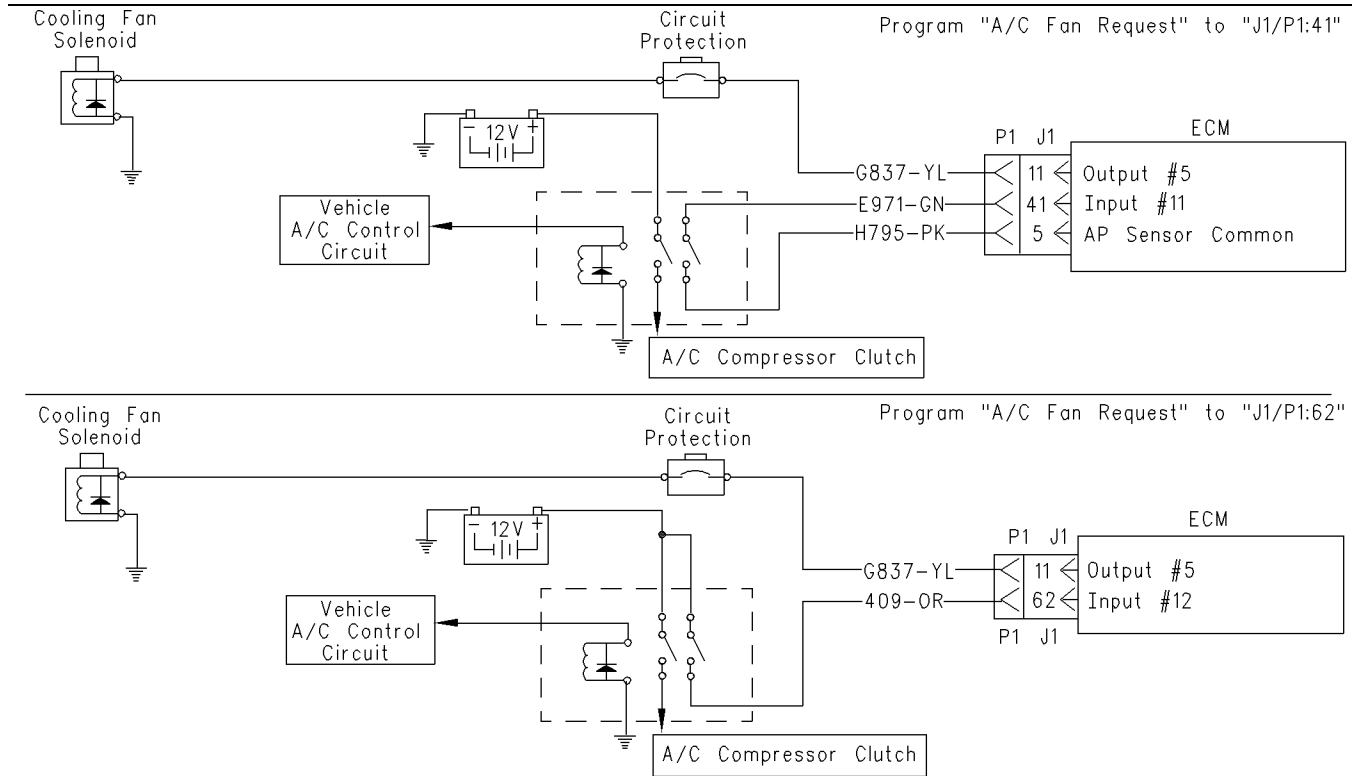

Illustration 60
 Cooling fan circuit

g00840480

Table 153

The following conditions will turn the Fan ON for Illustration 60.	
Circuit	Condition that will turn the Fan ON
Coolant temperature sensor	The coolant temperature is greater than 96 °C (205 °F). A diagnostic code for the coolant temperature sensor is active.
Exhaust brake	The "Fan with Exhaust Brake ON" parameter is programmed to "YES". The exhaust brake is on at least two seconds.
OEM installed A/C high pressure switch	The "A/C Switch Fan On-Time" is programmed to a value above 0. The switch circuit is open or on. The external timer is counting or the timer in the ECM is counting.
OEM installed A/C compressor clutch circuit	The "A/C Fan Request" is programmed to "J1/P1:41" or "J1/P162". The A/C compressor clutch is engaged.
The engine rpm is less than 2750 rpm.	The engine is cranking. The engine has been running two seconds or the ignition key is ON and the engine OFF.
Air inlet temperature sensor	The temperature in the air inlet manifold is greater than 87 °C (189 °F). The temperature in the air inlet manifold is greater than 72 °C (162 °F) while the boost pressure is greater than 70 kPa (10 psi).
OEM installed manual fan override switch	There is an open circuit in the switch or the switch is ON.
OEM installed cooling fan air solenoid valve	Open solenoid circuit
Circuit breaker for the cooling fan	Tripped breaker or open circuit
Dedicated PTO on/off switch	The "PTO Configuration" is programmed. The "PTO Activates Cooling Fan" is programmed. There is a short circuit in the switch or the switch is on.

Test Step 1. Inspect Electrical Connectors and Wiring.

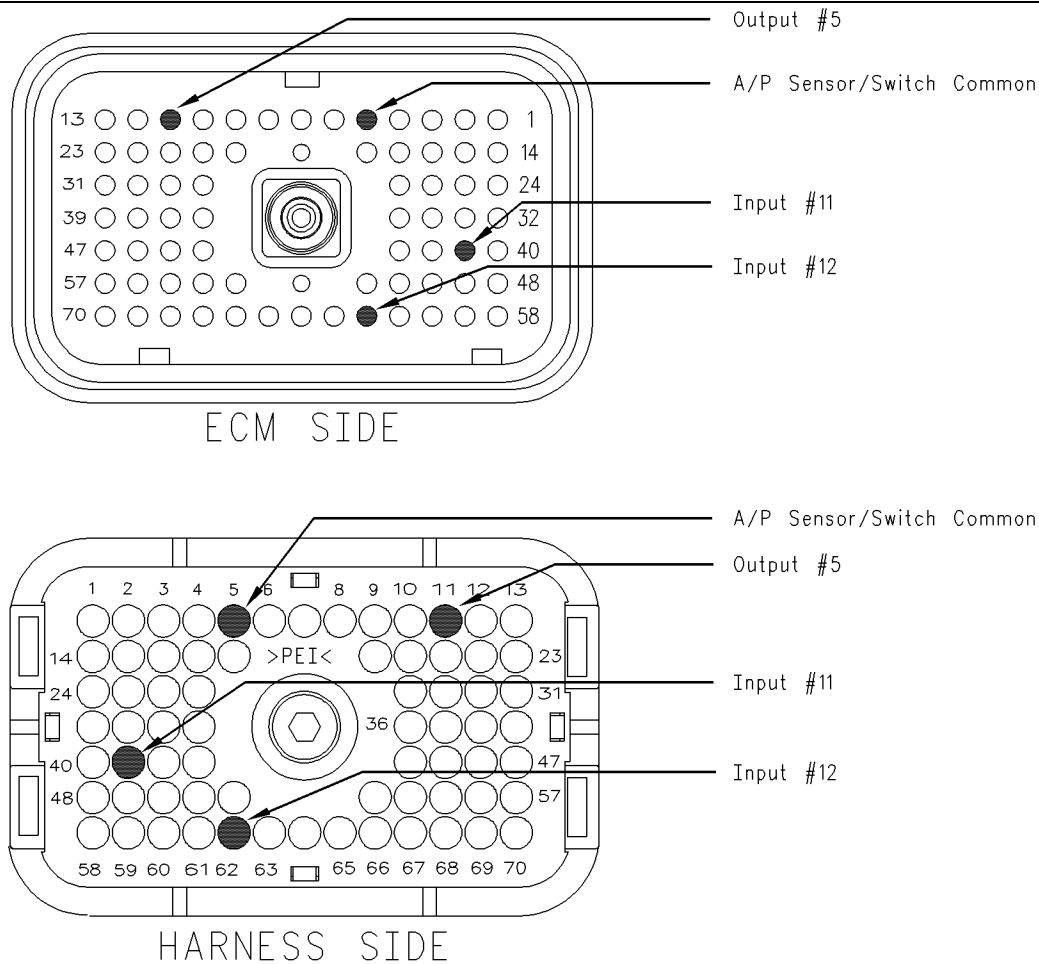

Illustration 61

g00840659

Terminal locations for the ECM connector (P1)

- A.** Thoroughly inspect the ECM vehicle harness connector J1/P1, the connector on the clutch for the A/C compressor, the connections to the cooling fan solenoid, and the firewall bulkhead connectors. Refer to Troubleshooting, "Electrical Connectors - Inspect" for details.
- B.** Perform a 45 N (10 lb) pull test on each of the wires in the ECM connector that are associated with the following connections:
 - Cooling fan
 - circuit for the clutch of the A/C compressor
- C.** Check the ECM connector (allen head screw) for the proper torque of 6.0 N·m (55 lb in).

- D.** Check the harness and the wiring for abrasion and pinch points from the battery to the ECM. Then, check from the ignition key switch to the ECM.
- E.** Ensure that the cooling fan on the vehicle is wired to the ECM. Check for wires that are connected to terminal 11 (output 5), terminal 62 (input 12) or terminal 41 (input 11).

Refer to Illustration 61 for terminal locations for the ECM.

Expected Result:

All connectors, pins, and sockets are completely coupled and/or inserted, and the harness and wiring should be free of corrosion, abrasion or pinch points.

Results:

- OK – Proceed to Test Step 2.
- Not OK

Repair: Repair the wiring or replace the wiring, if necessary. Repair the connectors or replace the connectors, if necessary. Ensure that all of the seals are in the proper place. Ensure that all of the connectors are connected properly.

Verify that the repair eliminates the problem.

STOP.

- **ECM not wired to fan or switch** – If the cooling fan on the vehicle is not wired to the ECM then the ECM is not being used for fan control. **STOP.**

Test Step 2. Check the Programming of the “Fan Control Type” Parameter.

- Connect an electronic service tool to the cab data link connector.
- Check the “Fan Control Type” parameter. Ensure that the parameter is programmed to “On-Off”, if the ECM is used to control the fan. If the parameter is programmed to “None” and the ECM is connected to the fan, then the fan will always be ON.

Expected Result:

The “Fan Control Type” parameter is programmed to match the vehicle wiring. This is determined in the previous step.

Results:

- **Yes** – Proceed to Test Step 3.
- **No** – Program the “Fan Control Type” to the correct setting and then recheck the system. If conditions are not resolved, then proceed to Test Step 3.

Test Step 3. Use the Electronic Service Tool to Verify that the Parameters are Correctly Programmed.

- Connect the electronic service tool to the cab data link connector.
- Turn the ignition key switch to the ON position.
- View the following Customer Specified Parameters.
 - “Fan Control Type”
 - “A/C Fan Request”

- “A/C Switch Fan On-Time”

Ensure that the “A/C Fan Request” parameter is programmed to “J1/P1:41” or “J1/P1:62”. If the “A/C Fan Request” is not programmed to “J1/P1:41” or “J1/P1:62”, the A/C compressor clutch will not turn on the fan .

Ensure that the “A/C Switch Fan On-Time” parameter is programmed to a value that is between “0” and “600”. If this parameter is programmed to “0”, Input #11 is not used.

Note: If the “Fan Control Type” parameter indicates “None”, then the cooling fan driver is not used.

Expected Result:

All three parameters are programmed correctly.

Results:

- **Yes** – The parameters are programmed correctly. Proceed to Test Step 4.
- **No** – Change the parameters to the correct settings. Proceed to Test Step 4.

Test Step 4. Use the Electronic Service Tool to Check Active Codes or Logged Codes.

- Connect the electronic service tool to the cab data link connector.
- Turn the ignition key switch to the ON position.
- Access the logged diagnostic codes and the active diagnostic codes on the electronic service tool.
- Check for the following diagnostic codes.
 - 110-00 High Coolant Temperature Warning
 - 110-11 Very High Coolant Temperature
 - 110-03 Coolant Temp Sensor Open Circuit
 - 110-04 Coolant Temp Sensor Short Circuit

Record any logged diagnostic codes. Record any active diagnostic codes.

Expected Result:

Result 1 None of the diagnostic codes that are listed are logged or active.

Result 2 Diagnostic Code 110-00, or 110-11 is logged or active.

Result 3 Diagnostic Code 110-03 or 110-04 is logged or active.

Results:

- **Result 1** – Proceed to Test Step 5.
- **Result 2** – The cooling fan is ON because of a high coolant temperature.

Repair: Perform the following diagnostic procedure: Troubleshooting, “110-11 Very High Coolant Temperature”

STOP.

- **Result 3** – The cooling fan is ON because of a coolant temperature sensor fault.

Repair: Perform the following diagnostic procedure: Troubleshooting, “Engine Temperature Sensor Open or Short Circuit - Test”

STOP.

Test Step 5. Check the A/C Compressor Clutch Switch.

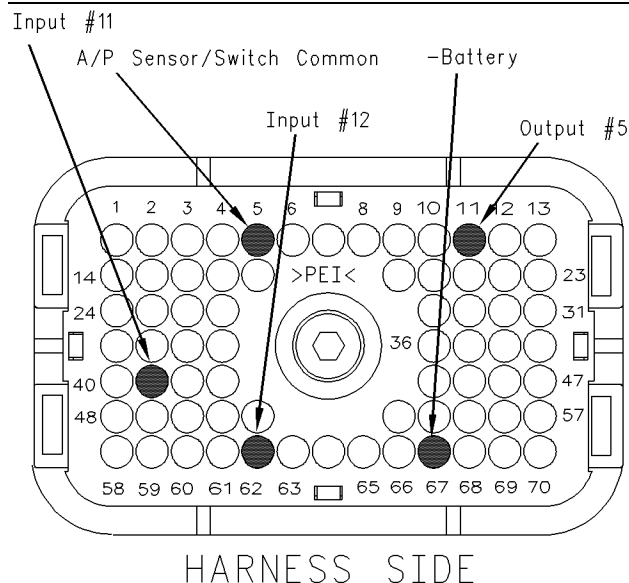

Illustration 62
Pin locations on P1 connector
g00841499

- A.** Turn the ignition key switch to the OFF position.
- B.** If the A/C compressor clutch switch is connected to P1:41 Input #11, use the following steps to check the switch circuit.
 - a.** Disconnect the wires at terminals P1:41 and P1:5.

- b.** Connect a multimeter and measure the resistance between the two terminals of the A/C compressor clutch switch. The A/C compressor clutch must be engaged in order to check the resistance.

- c.** The resistance should measure 10 Ohms or less.

C. If the A/C compressor clutch switch is connected to P1:62 (Input #12), use the following steps to check the switch circuit.

- a.** Disconnect the wire at terminal P1:62 (Input #12).

- b.** Connect a voltage test lamp between the wire that was removed from terminal P1:62 and terminal 67 (- Battery).

- c.** Turn the keyswitch to the ON position. The A/C compressor clutch must be engaged in order to check the A/C compressor clutch switch.

- d.** The test lamp should illuminate when the A/C compressor clutch is engaged.

Expected Result:

The circuit behaved in the manner that was described in the instructions above.

Results:

- **Yes** – The A/C compressor clutch switch and the wiring are electrically OK. Proceed to Test Step 6.
- **No**

Repair: Replace the A/C compressor clutch switch and/or the related wiring.

Verify that the repair eliminates the problem.

STOP.

Test Step 6. Use the Electronic Service Tool to Check Inlet Manifold Air Temperature and the Coolant Temperature.

- A.** Connect the electronic service tool to the cab data link connector.

- B.** Turn the ignition key switch to the ON position.

C. Access the status screen. Locate the “Coolant Temperature” and the “Inlet Manifold Air Temperature” status screen. Monitor the status screen for a few minutes in order to verify that the temperatures are changing as the engine warms up.

Expected Result:

The “Coolant Temperature” and the “Inlet Manifold Air Temperature” appear to have the correct reading.

Results:

- Yes – Proceed to Test Step 7.
- No

Repair: Temporarily connect another sensor. Test the new sensor by checking “Inlet Manifold Air Temperature” and “Coolant Temperature” again. If the problem is resolved with the new sensor, then reconnect the old sensor in order to verify that the problem returns. If the problem returns, then replace the old sensor.

Verify that the repair eliminates the problem.

STOP.

Test Step 7. Use the “Cooling Fan Solenoid Special Test” on the Electronic Service Tool to Check the Circuit.

- A. Connect the electronic service tool to the cab data link connector.
- B. Turn the ignition key switch to the ON position.
- C. Access the “Cooling Fan Solenoid Special Test”. Access each menu in the order that follows:
 - Diagnostics
 - Diagnostic Tests
 - Special Test

Note: If any override switches are installed, the switch must be in the OFF position.

D. Cycle the test to the ON position and to the OFF position. Listen for the solenoid to click. You may need to be near the engine in order to hear the click of the solenoid.

Expected Result:

An audible clicking is heard, and the solenoid appears to be operating properly.

Results:

- Yes – The cooling fan circuit from the ECM to the solenoid is functioning properly at this time.

Repair: If a problem still exists, then the problem is in the wiring that was installed by the OEM. Repair the problem or send the vehicle to the OEM dealer for repair.

Verify that the repair eliminates the problem.

STOP.

- No – Proceed to Test Step 8.

Test Step 8. Use the “Cooling Fan Solenoid Special Test” on the Electronic Service Tool to Check the ECM.

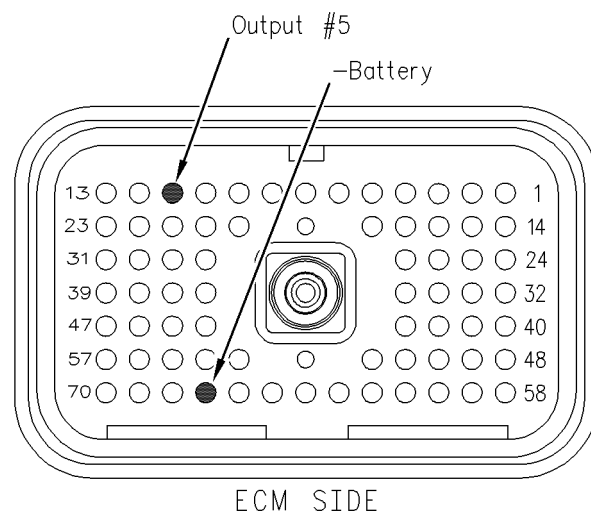

Illustration 63

g00841548

- A. Turn the ignition key switch to the OFF position.
- B. Disconnect the ECM vehicle harness connector J1/P1.
- C. Remove terminal 11 (Output 5) from the vehicle harness connector P1.
- D. Connect a Breakout T to the ECM connector J1 and vehicle harness connector P1.
- E. Connect a voltage test lamp between terminal 11 (Output 5) and terminal 67 (negative battery) of the breakout T.
- F. Turn the ignition key switch to the ON position.
- G. Access the “Cooling Fan” test on the electronic service tool.

Start the “Cooling Fan” test and stop the “Cooling Fan” test. At the same time, watch the voltage test lamp.

Note: A multimeter can not be used in place of the voltage test lamp when the ECM output is tested.

Expected Result:

The voltage test lamp turns on when the test is active. The voltage test lamp turns off when the test is not active.

Results:

- **Yes** – The output for the ECM cooling fan relay is functioning properly.

Repair: If a problem still exists, then the problem is in the wiring that was installed by the OEM. Repair the problem or send the vehicle to the OEM dealer for repair.

Verify that the repair eliminates the problem.

STOP.

- **No**

Repair: Temporarily connect a test ECM. Use the special test on the electronic service tool to check the ECM cooling fan circuit. If the problem is resolved with the test ECM, install the suspect ECM. If the problem returns with the suspect ECM, replace the ECM.

Verify that the repair eliminates the problem.

STOP.

i01606147

Cooling Fan Circuit and A/C High Pressure Switch Circuit - Test

SMCS Code: 1359-081-ZS; 1408-081; 1802-081-ZS

System Operation Description:

Use this procedure under the following situation:

Use this procedure to determine if the cooling fan (output 5) or the A/C high pressure switch (input 11) is operating correctly.

Note: Not all vehicle manufacturers, or all trucks for a manufacturer use the Caterpillar cooling fan circuit. Prior to troubleshooting, determine if the vehicle is using the ECM cooling fan circuit.

Check the following items in order to determine if a vehicle is using the ECM cooling fan circuit:

- The “Fan Control Type” parameter must be programmed to “On/Off” or one of the variable speed options. The Caterpillar factory default is None.
- “A/C Fan On Time” is programmed between one second and 600 seconds.
- A wire is present in the ECM vehicle harness connector J1/P1 (terminal 11) which is output 5 (cooling fan solenoid). This occurs if an On/Off type of fan is used.
- Perform the Special Test for the “On/Off Cooling Fan”. Access each menu in the order that follows: “Diagnostics”, “Diagnostic Tests”, and “Special Test”. Activating and then deactivating the circuit should cause the air solenoid to click if the circuit is working properly.

The following background information is related to this procedure:

Cooling Fan

The signal for the cooling fan is provided by the ECM in order to control the cooling fan. An input from one of the following items may cause the fan to turn ON:

- Engine coolant temperature sensor
- Air inlet temperature sensor
- Exhaust brake
- PTO on/off switch
- OEM installed A/C high pressure switch
- Manual fan override switch

A control unit for the A/C may be connected to the A/C high pressure switch (input 11) instead of a switch.

The output for the cooling fan is intended to connect directly to the circuit for the cooling fan solenoid. Program the “Fan Control Type” parameter to “ON/OFF”. The fan will be off when the ECM output is ON (energized). When the ECM activates the fan, the fan will remain on for a minimum of 30 seconds except for the following conditions:

- Engine start-up
- The “A/C Pressure Switch Fan On Time” is programmed to less than 30 seconds.

During engine start-up, the ECM will keep the fan ON for two seconds after the engine has reached the programmed low idle (700 to 800 rpm). The fan will be ON continuously if the electrical circuit to the cooling fan air solenoid valve has an open circuit or if the ECM Fan Relay circuit is opened.

Cooling Fan ON Conditions

The ECM will turn the cooling fan ON under any of the following circumstances if engine speed is less than 2750 rpm:

- The engine is not running.
- Engine cranking
- The coolant temperature is greater than 96 °C (205 °F).
- Active diagnostic code for the coolant temperature sensor
- The inlet manifold air temperature is greater than 87 °C (189 °F).
- The inlet manifold air temperature is greater than 72 °C (162 °F) while the boost pressure is greater than 70 kPa (10 psi).
- The manual fan override switch is on.
- The “Fan with Exhaust Brake ON” is programmed to “YES” and the exhaust brake has been on at least two seconds.
- The “A/C Switch Fan On-Time” is programmed to a value above 0 and the A/C high pressure switch is open.
- The ECM is counting after the A/C high pressure switch has closed.
- The “PTO Activates Cooling Fan” parameter is programmed to “Continuous” and the PTO on/off switch is on.

The last four items in the previous list are dependent upon the programming of the Customer Parameters.

Note: The ECM will turn OFF the cooling fan for 10 seconds during engine shutdown.

Cooling Fan OFF Conditions

The cooling fan will be turned OFF by the ECM if engine rpm exceeds 2800 rpm or when all the following circumstances are met:

- The coolant temperature is less than 92 °C (198 °F).
- The fan has been ON for at least 30 seconds.
- The inlet manifold air temperature is less than 53 °C (127 °F).
- The strategy for the exhaust brake is not active and the “Fan with Exhaust Brake ON” parameter is programmed to “YES”.
- The A/C high pressure switch is not active.
- The PTO on/off switch is in the OFF position and the “PTO Activates Cooling Fan” parameter is programmed to “Continuous”.
- The manual fan override switch is OFF.

A/C High Pressure Switch Input Connected to A/C Control Unit.

A control unit for the A/C that is supplied by the OEM may be used. The control unit for the A/C determines when the cooling fan should operate. This is based on the following input information:

- A/C high pressure switch
- low pressure switch
- evaporator thermostat

The output for the fan for the control unit to the A/C is designed to interface with the ECM. The output for the fan may be connected to the input for the A/C high pressure switch. The input for the A/C high pressure switch is Input 11 of the ECM connector J1/P1 terminal 41. The fan is in the ON position when the A/C high pressure switch is in the OPEN position. This type of control has a time delay. Typically, the “A/C Switch Fan On-Time” is programmed to one second since the control unit for the A/C provides an additional time delay.

The Cooling Fan Control can be Operated Independently of the ECM.

Operation of the cooling fan control can be controlled independently of the ECM. The OEM installed air conditioning high pressure switch may be used for independent cooling fan control. A cab mounted override switch in the solenoid circuit can also operate the cooling fan.

Troubleshooting

Before troubleshooting the cooling fan circuit, determine the type of fan drive system that is used. The fan drive can use the following controls in order to control the fan:

- normally open with a pneumatic air solenoid
- normally closed with a pneumatic air solenoid
- normally open with an electrically controlled solenoid
- normally closed with an electrically controlled solenoid

The following OEM installed components may affect the operation of the cooling fan in some applications:

- OEM installed, normally open relay
- The a/c high pressure switch is connected to the ECM or the a/c high pressure switch is independent of the ECM.
- Cab mounted manual override switch
- A timer that keeps the fan in the ON position
- Cooling fan air solenoid valve

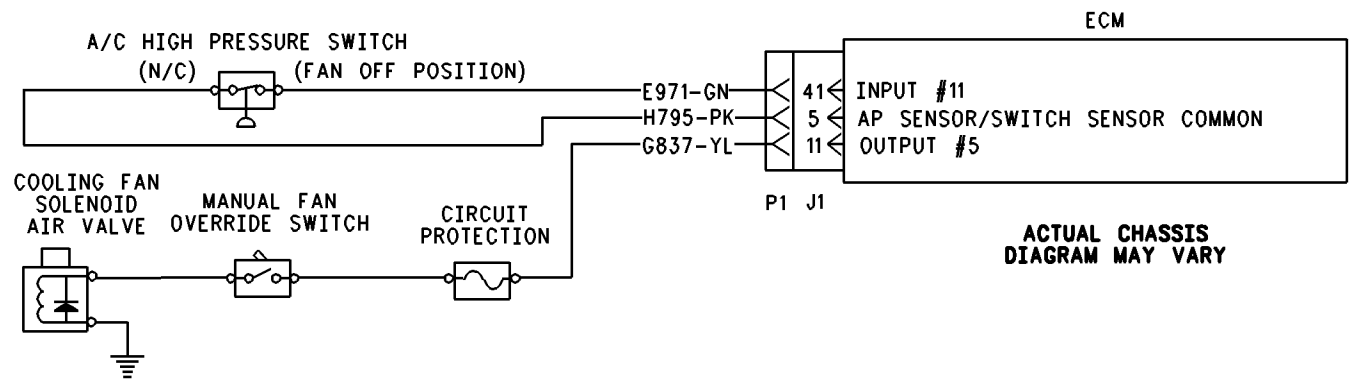

Illustration 64

g00766507

This schematic represents the on/off fan with a direct solenoid connection to the ECM and the A/C pressure switch connected to the ECM input.

Table 154

The following conditions will turn the Fan ON for Illustration 64.	
Circuit	Condition that will turn the Fan ON
Coolant temperature sensor	The coolant temperature is greater than 96 °C (205 °F). A diagnostic code for the coolant temperature sensor is active.
Exhaust brake	The "Fan with Exhaust Brake ON" parameter is programmed to "YES". The exhaust brake is on at least two seconds.
OEM installed A/C high pressure switch	The "A/C Switch Fan On-Time" is programmed to a value above 0. The switch circuit is open or on. The external timer is counting or the ECM timer is counting.
The engine rpm is less than 2750 rpm.	The engine is cranking. The engine has been running two seconds or the ignition key is ON and the engine OFF.
Air inlet temperature sensor	The temperature in the air inlet manifold is greater than 87 °C (189 °F). The temperature in the air inlet manifold is greater than 72 °C (162 °F) while the boost pressure is greater than 70 kPa (10 psi).
OEM installed manual fan override switch	There is an open circuit in the switch or the switch is ON.
OEM installed cooling fan air solenoid valve	Open solenoid circuit
Circuit breaker for the cooling fan	Tripped breaker or open circuit
Dedicated PTO on/off switch	The "PTO Configuration" is programmed. The "PTO Activates Cooling Fan" is programmed. There is a short circuit in the switch or the switch is on.

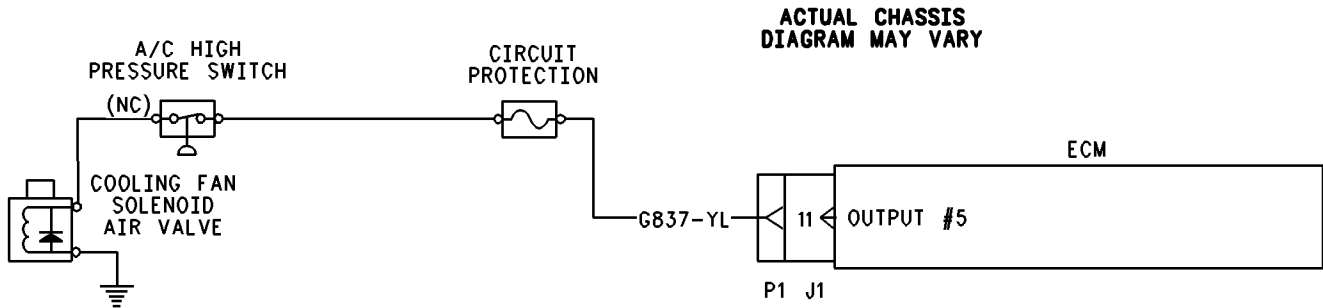

Illustration 65

g00766679

This schematic represents an on/off fan with a direct solenoid connection to the ECM and the A/C high pressure switch is not connected to the ECM input.

Table 155

The following conditions will turn the Fan ON for Illustration 65.	
Circuit	Condition that will turn the Fan ON
Coolant temperature sensor	The coolant temperature is greater than 96 °C (205 °F). A diagnostic code for the coolant temperature sensor is active.
Exhaust brake	The "Fan with Exhaust Brake ON" parameter is programmed to "YES". The exhaust brake is on at least two seconds.
OEM installed A/C high pressure switch	The switch circuit is open or ON.
The engine rpm is less than 2750 rpm.	The engine is cranking. The engine has been running for two seconds or the ignition key is in the ON position and the engine off.
Air inlet temperature sensor	The temperature in the air inlet manifold is greater than 87 °C (189 °F). The temperature in the air inlet manifold is greater than 72 °C (162 °F) while the boost pressure is greater than 70 kPa (10 psi).
OEM installed cooling fan air solenoid valve	Open solenoid circuit
Circuit breaker for the cooling fan	Tripped breaker or open circuit
Dedicated PTO on/off switch	The "PTO Configuration" is programmed. The "PTO Activates Cooling Fan" is programmed. There is a short circuit in the switch or the switch is ON.

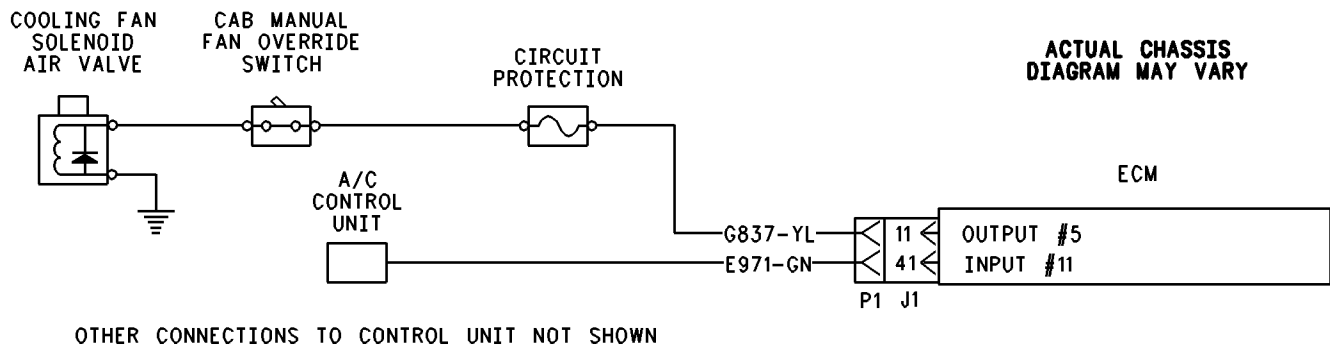

Illustration 66

g00675587

This schematic represents the on/off fan with a direct solenoid connection to the ECM and the control unit for the A/C connected to the ECM input.

Table 156

The following conditions will turn the Fan ON for Illustration 66.	
Circuit	Condition that will turn the Fan ON
Coolant temperature sensor	The coolant temperature is greater than 96 °C (205 °F). A diagnostic code for the coolant temperature sensor is active.
Exhaust brake	The "Fan with Exhaust Brake ON" parameter is programmed to "YES". The exhaust brake is on at least two seconds.
OEM installed A/C control unit	The "A/C Switch Fan On-Time" parameter is programmed to a value above 0 seconds. The A/C control unit circuit is open. The external timer is counting or the ECM timer is counting.
The engine rpm is greater than 2750 rpm.	The engine is cranking. The engine has been running two seconds or the ignition key is on the ON position and the engine off.
Air inlet temperature sensor	The temperature in the air inlet manifold is greater than 87 °C (189 °F). The temperature in the air inlet manifold is greater than 72 °C (162 °F) while the boost pressure is greater than 70 kPa (10 psi).
OEM installed manual fan override switch	There is an open circuit in the switch or the switch is on.
OEM installed cooling fan air solenoid valve	Open solenoid circuit
Circuit breaker for the cooling fan	Tripped breaker or open circuit
Dedicated PTO on/off switch	The "PTO Configuration" is programmed. The "PTO Activates Cooling Fan" is programmed. There is a short circuit in the switch or the switch is on.

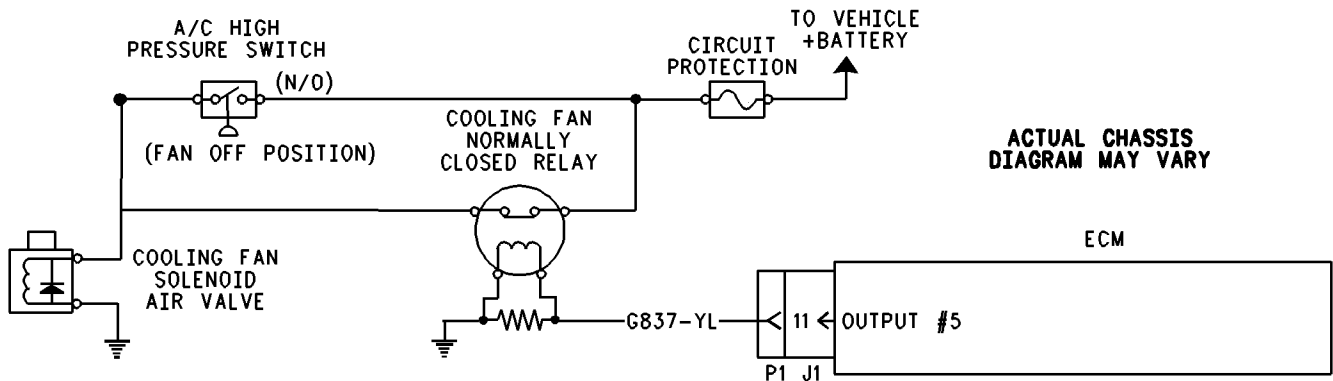

Illustration 67

g00766689

This schematic represents the on/off fan with a normally closed relay and the A/C high pressure switch that is not connected to the ECM input.

Table 157

The following conditions will turn the Fan ON for Illustration 67.	
Circuit	Condition that will turn the Fan ON
Coolant temperature sensor	The coolant temperature is greater than 96 °C (205 °F). A diagnostic code for the coolant temperature sensor is active.
Exhaust brake	The "Fan with Exhaust Brake ON" parameter is programmed to "YES". The exhaust brake is on at least two seconds.
OEM installed A/C high pressure switch	The circuit for the switch is closed or the switch is on.
The engine rpm is less than 2750 rpm.	The engine is cranking. The engine has been running two seconds or the ignition key is on the ON position and the engine off.
Air inlet temperature sensor	The temperature in the air inlet manifold is greater than 87 °C (189 °F). The temperature in the air inlet manifold is greater than 72 °C (162 °F) while the boost pressure is greater than 70 kPa (10 psi).
OEM installed cooling fan air solenoid valve	The solenoid is energized.
OEM installed cooling fan relay	There is an open circuit on the coil side of the relay.
Dedicated PTO on/off switch	The "PTO Configuration" is programmed. The "PTO Activates Cooling Fan" is programmed. There is a short circuit in the switch or the switch is on.

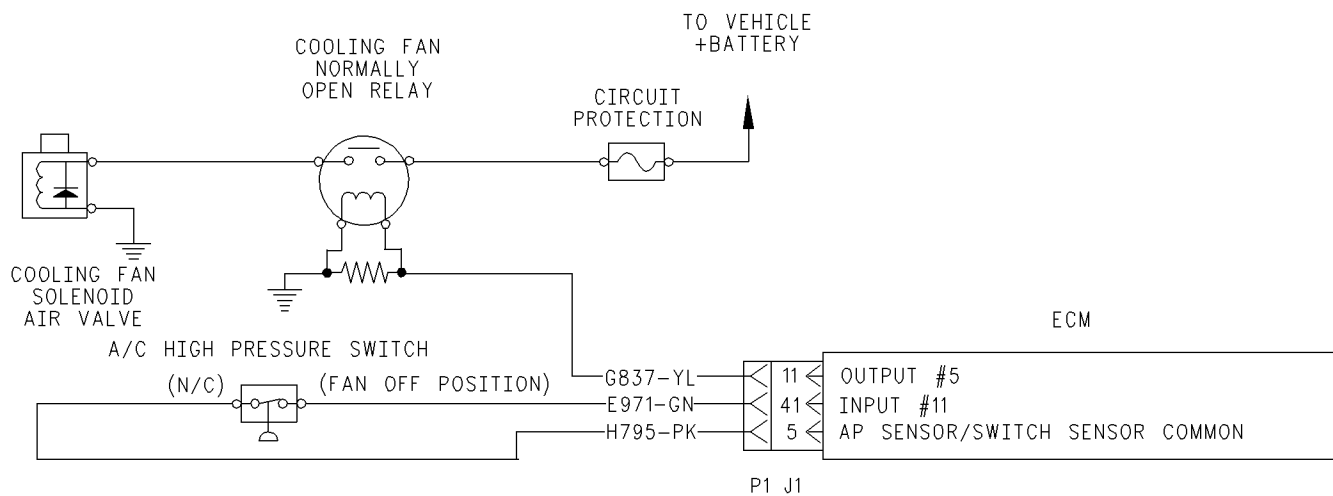

ACTUAL CHASSIS
DIAGRAM MAY VARY

Illustration 68

g00845731

This schematic represents the on/off fan with a normally open relay connection and an A/C high pressure switch connected to the ECM input.

Table 158

The following conditions will turn the Fan ON for Illustration 68.	
Circuit	Condition that will turn the Fan ON
Coolant temperature sensor	The coolant temperature is greater than 96 °C (205 °F). A diagnostic code for the coolant temperature sensor is active.
Exhaust brake	The "Fan with Exhaust Brake ON" parameter is programmed to "YES". The exhaust brake is on at least two seconds.
OEM installed A/C high pressure switch	The "A/C Switch Fan On-Time" parameter is programmed to a value above 0 seconds. The switch circuit is open or the switch is on. The external timer is counting or the ECM timer is counting.
The engine rpm is less than 2750 rpm.	The engine is cranking. The engine has been running two seconds or the ignition key is on the ON position and the engine off.
Air inlet temperature sensor	The temperature in the air inlet manifold is greater than 87 °C (189 °F). The temperature in the air inlet manifold is greater than 72 °C (162 °F) while the boost pressure is greater than 70 kPa (10 psi).
OEM installed cooling fan relay	Open circuit in either coil or contact side of relay
OEM installed cooling fan air solenoid valve	Open solenoid circuit
Circuit breaker for the cooling fan	Tripped breaker or open circuit
Dedicated PTO on/off switch	The "PTO Configuration" is programmed. The "PTO Activates Cooling Fan" is programmed. There is a short circuit in the switch or the switch is on.

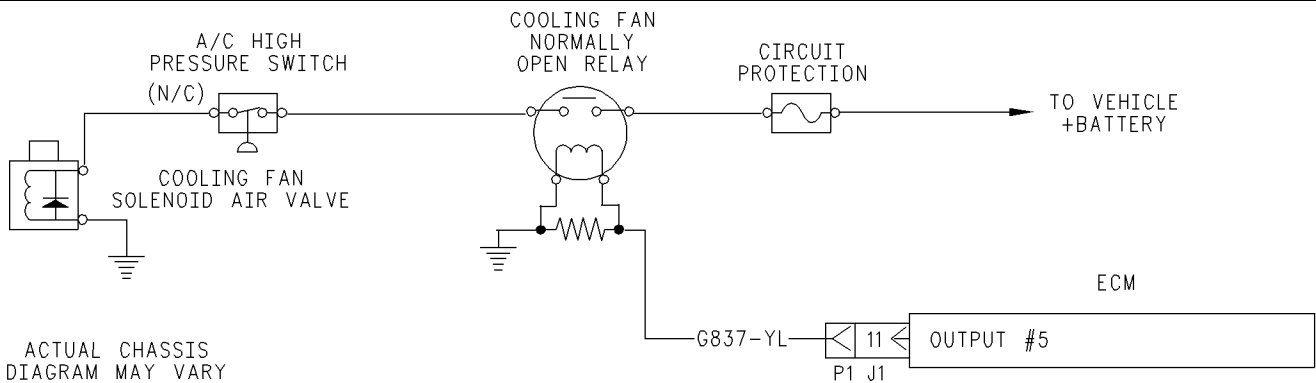

Illustration 69

g00845732

This schematic represents the on/off fan with a normally open relay connection and an A/C high pressure switch connected between the solenoid and the relay.

Table 159

The following conditions will turn the Fan ON for Illustration 69.	
Circuit	Condition that will turn the Fan ON
Coolant temperature sensor	The coolant temperature is greater than 96 °C (205 °F). A diagnostic code for the coolant temperature sensor is active.
Exhaust brake	The "Fan with Exhaust Brake ON" parameter is programmed to "YES". The exhaust brake is on at least two seconds.
OEM installed A/C high pressure switch	The switch circuit is open or the switch is ON.
The engine rpm is less than 2750 rpm.	The engine is cranking. The engine has been running two seconds or the ignition key is on the ON position and the engine off.
Air inlet temperature sensor	The temperature in the air inlet manifold is greater than 87 °C (189 °F). The temperature in the air inlet manifold is greater than 72 °C (162 °F) while the boost pressure is greater than 70 kPa (10 psi).
OEM installed cooling fan relay	Open circuit in either coil or contact side of relay
OEM installed cooling fan air solenoid valve	Open solenoid circuit
Circuit breaker for the cooling fan	Tripped breaker or open circuit
Dedicated PTO on/off switch	The "PTO Configuration" is programmed. The "PTO Activates Cooling Fan" is programmed. There is a short circuit in the switch or the switch is on.

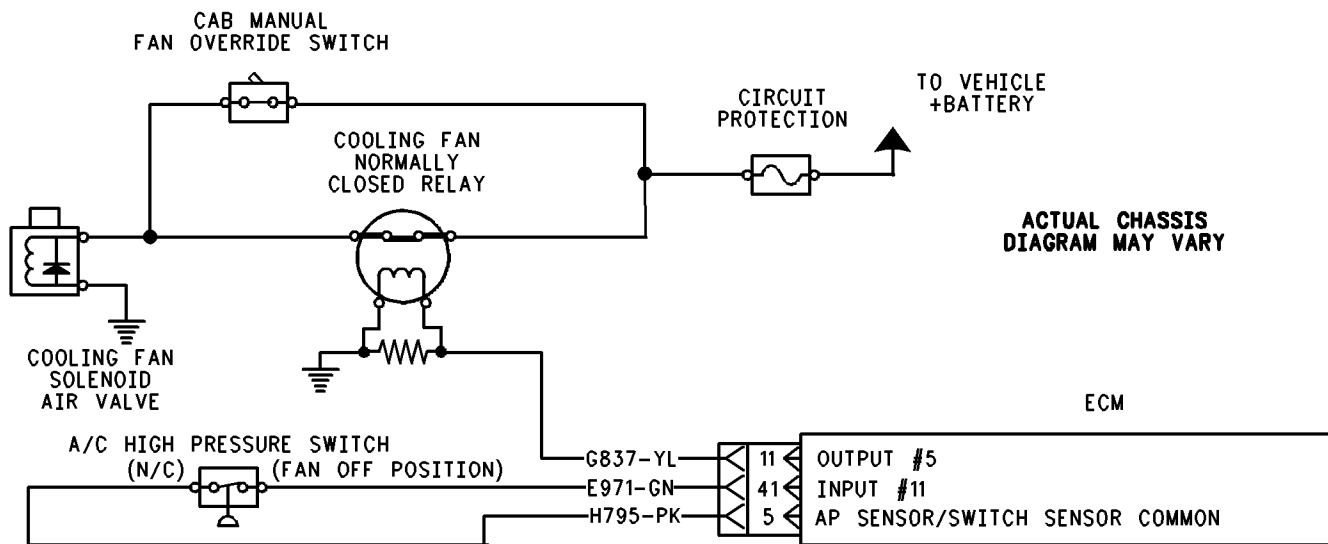

Illustration 70

g00675642

This schematic represents the on/off fan with a normally closed relay connection and an A/C high pressure switch connected to the ECM input.

Table 160

The following conditions will turn the Fan ON for Illustration 70.	
Circuit	Condition that will turn the Fan ON
Coolant temperature sensor	The coolant temperature is greater than 96 °C (205 °F). A diagnostic code for the coolant temperature sensor is active.
Exhaust brake	The "Fan with Exhaust Brake ON" parameter is programmed to "YES". The exhaust brake is on at least two seconds.
OEM installed A/C high pressure switch	The "A/C Switch Fan On-Time" parameter is programmed to a value above 0 seconds. The switch circuit is open or the switch is on. The external timer is counting or the ECM timer is counting.
The engine rpm is less than 2750 rpm.	The engine is cranking. The engine has been running two seconds or the ignition key is on the ON position and the engine off.
Air inlet temperature sensor	The temperature in the air inlet manifold is greater than 87 °C (189 °F). The temperature in the air inlet manifold is greater than 72 °C (162 °F) while the boost pressure is greater than 70 kPa (10 psi).
OEM installed manual fan override switch	There is a short circuit in the switch or the switch is on.
OEM installed cooling fan air solenoid valve	The solenoid is energized.
OEM installed Cooling Fan Relay	Open circuit in coil side of relay
Dedicated PTO on/off switch	The "PTO Configuration" is programmed. The "PTO Activates Cooling Fan" is programmed. There is a short circuit in the switch or the switch is on.

Test Step 1. Inspect Electrical Connectors and Wiring.

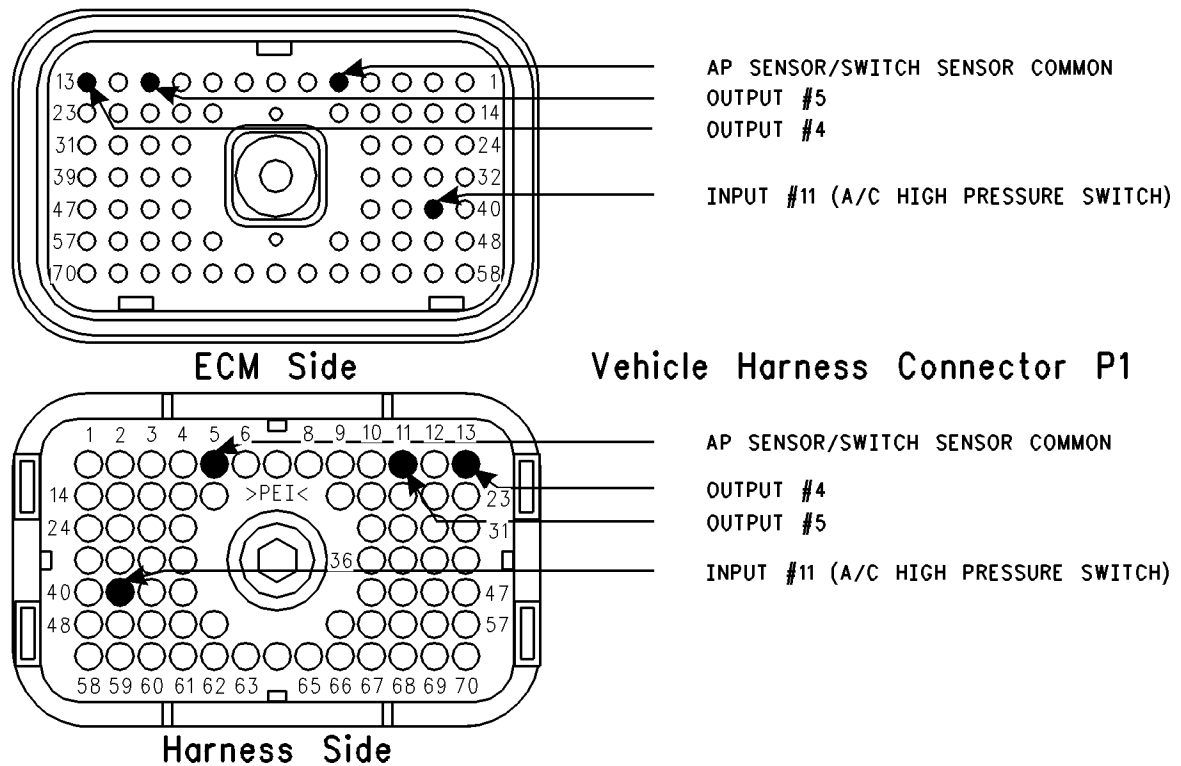

Illustration 71

g00675876

Terminal locations for the ECM

- A.** Thoroughly inspect the ECM vehicle harness connector J1/P1, the A/C high pressure switch connector, the connections to the cooling fan solenoid, and the firewall bulkhead connectors. Refer to Troubleshooting, "Electrical Connectors - Inspect" for details.
- B.** Perform a 45 N (10 lb) pull test on each of the wires in the ECM connector that are associated with the following connections:
 - Cooling fan
 - A/C high pressure switch
- C.** Check the ECM connector (allen head screw) for the proper torque of 6.0 N·m (55 lb in).
- D.** Check the harness and the wiring for abrasion and pinch points from the battery to the ECM. Then, check from the ignition key switch to the ECM.

- E.** Ensure that the ECM is wired to the cooling fan on the vehicle and/or the A/C high pressure switch. Check for wires that are connected to terminal 11 (output 5) and for wires that are connected to terminal 41. Input 11 is the A/C high pressure switch of vehicle harness connector P1.

Refer to Illustration 71 for terminal locations for the ECM.

Expected Result:

All connectors, pins, and sockets are completely coupled and/or inserted, and the harness and wiring should be free of corrosion, abrasion or pinch points.

Results:

- OK – Proceed to Test Step 2.
- Not OK

Repair: Repair the wiring or replace the wiring, if necessary. Repair the connectors or replace the connectors, if necessary. Ensure that all of the seals are in the proper place. Ensure that all of the connectors are connected properly.

Verify that the repair eliminates the problem.

STOP.

- **ECM not wired to fan or switch** – If the ECM is not wired to the cooling fan on the vehicle and/or the A/C high pressure switch, then the ECM is not being used for fan control. STOP.

Test Step 2. Check the Programming of the “Fan Control Type” Parameter.

- Connect ET to the cab data link connector.
- Check the “Fan Control Type” parameter. Ensure that the parameter is programmed to “On-Off”, if the ECM is used to control the fan. If the parameter is programmed to “None” and the ECM is connected to the fan, then the fan will always be ON.

Expected Result:

The “Fan Control Type” parameter is programmed to match the vehicle wiring. This is determined in the previous step.

Results:

- **Yes** – Proceed to Test Step 3.
- **No** – Program the “Fan Control Type” to the correct setting and then recheck the system. If conditions are not resolved, then proceed to Test Step 3.

Test Step 3. Use ET to Check the A/C Pressure Switch.

- Connect ET at the cab data link connector.
- Turn the ignition key switch to the ON position.
- View the following Customer Specified Parameters.
 - “Fan Control Type”
 - “A/C Switch Fan On-Time”

Ensure that the “A/C Switch Fan On-Time” is programmed to a greater value than “0”. If the “A/C Switch Fan On-Time” is programmed to “0”, then the “A/C High Pressure Switch Input” (Input 11) is not used.

Note: If the “Fan Control Type” parameter indicates “None”, then the cooling fan driver is not used.

View the “A/C High Pressure Switch” status on ET.

Expected Result:

The status of the A/C high pressure switch indicates ON or OFF.

Results:

- **Yes** – The status of the A/C high pressure switch is ON or OFF. Proceed to Test Step 4.
- **No** – The status of the A/C high pressure switch is “Unavailable”. The ECM is not programmed to use the A/C high pressure switch. Proceed to Test Step 5.

Test Step 4. Use ET to Check the Operation of the A/C Pressure Switch.

- Connect ET to the cab data link connector.
- Turn the ignition key switch to the ON position.
- Access the “A/C High Pressure Switch” status screen on ET.
- Fabricate a jumper wire 100 mm (4 inch) long. Crimp a Deutsch pin to both ends of the wire.
- Disconnect the “A/C High Pressure Switch” from the vehicle harness at the switch and use the jumper wire to short the two terminals in the harness connector together.
- Remove the jumper wire and then insert the jumper wire. At the same time, view the “A/C High Pressure Switch” status on the service tool status screen.

Expected Result:

The status screen indicates that the “A/C High Pressure Switch” is turning to the ON position. Then, the “A/C High Pressure Switch” is turning to the OFF position.

Results:

- **Yes** – The A/C high pressure switch harness is OK. Proceed to Test Step 6.
- **No** – Proceed to Test Step 7.

Test Step 5. Use ET to Check Active Codes or Logged Codes.

- Connect ET to the cab data link connector.
- Turn the ignition key switch to the ON position.
- Access the “Logged Diagnostic Codes” and the “Active Diagnostic Codes” on ET.
- Check for the following diagnostic codes.

- 110-00 High Coolant Temperature Warning
- 110-11 Very High Coolant Temperature
- 110-03 Coolant Temp Sensor Open Circuit
- 110-04 Coolant Temp Sensor Short Circuit

Record any logged diagnostic codes. Record any active diagnostic codes.

Expected Result:

Result 1 None of the diagnostic codes that are listed are logged or active.

Result 2 Diagnostic code 110-00, or 110-11 is logged or active.

Result 3 Diagnostic code 110-03 or 110-04 is logged or active.

Results:

- **Result 1** – Proceed to Test Step 8.
- **Result 2** – The cooling fan is ON because of a high coolant temperature.

Repair: Perform either of the following diagnostic procedures: Troubleshooting, “0110-00 High Coolant Temperature Warning” Troubleshooting, “0110-11 Very High Coolant Temperature”

STOP.

- **Result 3** – The cooling fan is ON because of a coolant temperature sensor fault.

Repair: Perform the following diagnostic procedure: Troubleshooting, “Engine Temperature Sensor Open or Short Circuit - Test”

STOP.

Test Step 6. Use a Voltmeter to Check the A/C Pressure Switch.

- A.** Connect ET to the cab data link connector.
- B.** Turn the ignition key switch to the OFF position.
- C.** Ensure that the A/C high pressure switch is disconnected from the vehicle harness at the switch terminals.
- D.** Connect a multimeter and measure the resistance between the two terminals of the A/C high pressure switch. The switch must be closed in order to check the resistance.

Expected Result:

The resistance measures 10 Ohms or less.

Results:

- **Yes** – The ECM, the A/C high pressure switch, and the wiring are electrically OK.

Repair: Check the A/C pressure or send the vehicle to the OEM dealer for repairs.

STOP.

- **No**

Repair: Replace the A/C high pressure switch.

Verify that the repair eliminates the problem.

STOP.

Test Step 7. Use ET to Check the ECM.

Illustration 72

g00676088

Connector for the Breakout T

- A. Connect ET to the cab data link connector.
- B. Turn the ignition key switch to the OFF position.
- C. Disconnect the ECM vehicle harness connector J1/P1.
- D. Remove terminal 41 (output 11) from the vehicle harness connector P1.
- E. Install a breakout T between connectors J1 and P1.
- F. Fabricate a jumper wire 100 mm (4 inch) long. Crimp a Deutsch pin to both ends of the wire.
- G. Connect the jumper wire to terminal 5 (ap sensor/switch common) and to terminal 41 (input 11) of the breakout T.

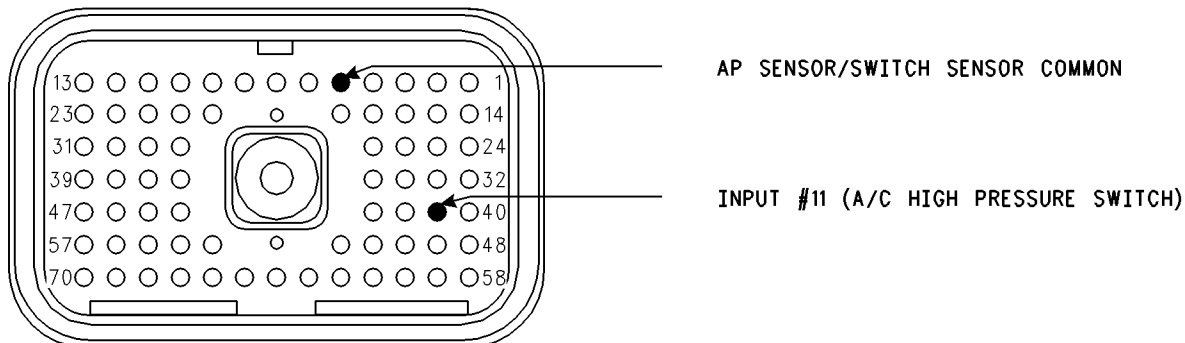
Refer to illustration 72.

- H. Turn the ignition key switch to the ON position.
- I. Access the “A/C High Pressure Switch” status screen on ET.
- J. Remove the jumper wire and then insert the jumper wire. At the same time, watch the “A/C High Pressure Switch” status on ET.

Expected Result:

The status screen indicates that the “A/C High Pressure Switch” status is OFF when the jumper wire is in place. The status screen indicates ON when the jumper wire is removed.

Results:

- Yes – The ECM is OK.

Repair: If a problem still exists, then the problem is in the OEM Wiring. Repair the problem or send the vehicle to the OEM dealer for repair. Verify that the repair eliminates the problem.

STOP.

- No

Repair: Temporarily connect a test ECM. Ensure that the “A/C Pressure Switch Fan On-Time” parameter is programmed in the same manner as the suspect ECM. Use ET to check the ECM. If the problem is resolved with the test ECM, install the suspect ECM. If the problem returns with the suspect ECM, replace the ECM.

Verify that the repair eliminates the problem.

STOP.**Test Step 8. Use ET to Check Inlet Manifold Air Temperature and the Coolant Temperature.**

- A. Connect ET to the cab data link connector.
- B. Turn the ignition key switch to the ON position.
- C. Access the status screen. Locate the “Coolant Temperature” and the “Inlet Manifold Air Temperature” status screen. Monitor the status screen for a few minutes in order to verify that the temperatures are changing as the engine warms up.

Expected Result:

The “Coolant Temperature” and the “Inlet Manifold Air Temperature” appear to have the correct reading.

Results:

- Yes – Proceed to Test Step 9.
- No

Repair: Temporarily connect another sensor. Test the new sensor by checking “Inlet Manifold Air Temperature” and “Coolant Temperature” again. If the problem is resolved with the new sensor, then install the old sensor in order to verify that the problem returns. If the problem returns, then replace the old sensor.

Verify that the repair eliminates the problem.

STOP.

Test Step 9. Use the “Cooling Fan Solenoid Special Test” on ET to Check the Circuit.

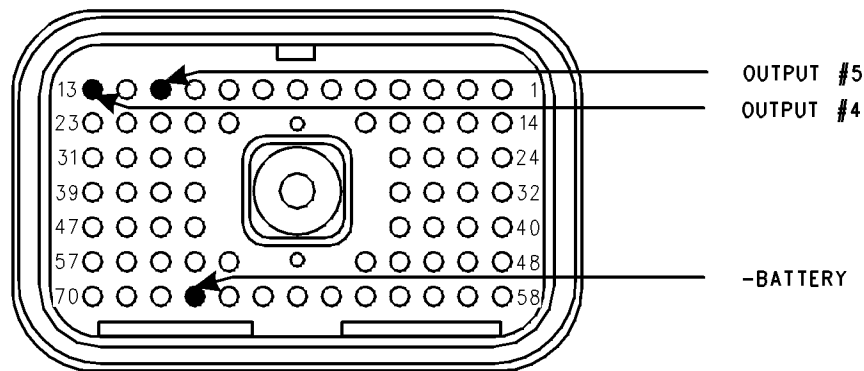

Illustration 73
Connector for the Breakout T

g00676097

- A.** Connect ET to the cab data link connector.
 - B.** Turn the ignition key switch to the ON position.
 - C.** Access the “Cooling Fan Special Test”. Access each menu in the order that follows:
 - Diagnostics
 - Diagnostic Tests
 - Special Test
- NOTE: If any override switches are installed, the switch must be in the OFF position.
- D.** Cycle the “Special Test” to the ON position and to the OFF position. Listen for the solenoid to click. You may need to be near the engine in order to hear the click of the solenoid.

Expected Result:

An audible clicking is heard, and the solenoid appears to be operating properly.

Results:

- **Yes** – The cooling fan circuit from the ECM to the Solenoid is functioning properly at this time.

Repair: If a problem still exists, then the problem is in the OEM Wiring. Repair the problem or send the vehicle to the OEM dealer for repair.

Verify that the repair eliminates the problem.

STOP.

- **No** – Proceed to Test Step 10.

i01604160

Test Step 10. Use the “Cooling Fan Solenoid Special Test” on ET to Check the ECM.

- A. Turn the ignition key switch to the OFF position.
- B. Disconnect the ECM vehicle harness connector J1/P1.
- C. Remove terminal 11 (Output 5) from the vehicle harness connector P1.
- D. Connect a breakout T to the ECM connector J1 and vehicle harness connector P1.
- E. Connect a voltage test lamp between terminal 11 (Output 5) and terminal 67 (negative battery) of the breakout T.
- F. Turn the ignition key switch to the ON position.
- G. Access the “Cooling Fan Special Test” on ET.

Cycle the “Cooling Fan Special Test” to the ON position and to the OFF position. At the same time, watch the voltage test lamp.

Note: A multimeter can not be used in place of the voltage test lamp when the ECM output is tested.

Expected Result:

The voltage test lamp turns to the ON position when the test is “Active”. The voltage test lamp turns to the OFF when the test is “NOT Active”.

Results:

- **Yes** – The output for the ECM cooling fan relay is functioning properly.

Repair: If a problem still exists, then the problem is in the OEM Wiring. Repair the problem or send the vehicle to the OEM dealer for repair.

Verify that the repair eliminates the problem.

STOP.

- **No**

Repair: Temporarily connect a test ECM. Use the special test on ET to check the ECM cooling fan circuit. If the problem is resolved with the test ECM, install the suspect ECM. If the problem returns with the suspect ECM, replace the ECM.

Verify that the repair eliminates the problem.

STOP.

Cruise Control Switch Circuit - Test

SMCS Code: 1900-081-ZS

System Operation Description:**Use this procedure under the following situation:**

Use this procedure to determine if one of the following switches is preventing normal operation of cruise control, fast idle, idle set speed, extended idle, or PTO operation:

- Cruise control on/off switch
- Cruise control set/resume switch

The following switch circuits can also prevent the correct operation of the cruise control, idle set speed, fast idle, extended idle, or PTO operation:

- Service brake pedal position (switch 1)
- Service brake pedal position (switch 2)
- Clutch switch
- Neutral switch
- Cruise control set/resume switch
- Cruise control on/off switch
- PTO on/off switch
- Cruise control pause switch

The switches are described in the respective circuit tests in Troubleshooting.

All of the following Customer Programmable Parameters can affect cruise control, fast idle, idle set speed, extended idle, and PTO operation:

- “Low Cruise Control Speed Set Limit”
- “High Cruise Control Speed Set Limit”
- “Idle Vehicle Speed Limit”
- “Idle RPM Limit”
- “Fast Idle RPM #1”
- “Fast Idle RPM #2”
- “Cruise/Idle/PTO Switch Configuration”
- “Idle/PTO Bump rpm”

- “Idle/PTO rpm Ramp Rate”
- “PTO Vehicle Speed Limit”

The vehicle speed calibration can also affect the cruise control, the fast idle, the idle set speed, extended idle, and the PTO if the vehicle speed calibration is incorrectly programmed. Refer to Troubleshooting, “Customer Specified Parameters”.

Cruise Control On/Off Switch

This switch must be ON before cruise control or controlled idle can be activated. This switch is ON when the switch is closed. When the switch is closed the following terminals are connected:

- ECM connector J1/P1 terminal 59 (cruise control on/off switch)
- Terminal 5 (ap sensor/switch sensor common)

This switch may not be connected to an input on the ECM. The parameter “Cruise Control On/Off Switch” determines the input to the ECM. If the parameter is programmed to J1/P1:59 a switch must be connected to terminal 59. If the parameter is programmed to one of the J1939 options, the switch position will be transmitted to the ECM over the J1939 data link. If a problem is suspected with the J1939 data link, refer to Troubleshooting, “Powertrain Data Link Circuit - Test”.

Note: If the vehicle is programmed to use the dedicated PTO, the PTO on/off switch overrides the cruise control on/off switch. The PTO on/off switch overrides the cruise control on/off switch when the vehicle speed is within the range of the “PTO Vehicle Speed Limit” that is programmed.

Set/Resume Switch

With the cruise control on/off switch in the ON position and the vehicle speed within the range of the programmed “Low Cruise Control Speed Set Limit” and the “High Cruise Control Speed Set Limit”, momentarily pressing the set switch will activate the cruise or controlled idle, and the ECM will maintain the current speed.

After a speed has been set and the speed is then disengaged by using the brake, the clutch, the cruise control pause switch, or the on/off switch, the ECM will seek the previous set speed when the resume switch is toggled. This assumes that the vehicle speed is above the “Low Cruise Control Speed Set Limit” for cruise control or the vehicle speed is below the “Idle/PTO Vehicle Speed Limit” for the idle and the PTO.

After a speed has been set, pressing and holding the set/resume switch in position will cause the engine to establish a new set speed. The system’s reaction depends on the programming of the “Cruise/Idle/PTO Switch Configuration”.

When the set/resume switch is momentarily pressed, the cruise set point will change one mph. The rate of change is dependent on the programmed “Idle/PTO Bump RPM” when an idle speed is set.

Cruise Control Pause Switch

The cruise control pause switch is not a switch that is wired to an input. The switch position is broadcast over a J1939 data link. The parameter “Cruise Pause Switch” must be programmed to use a cruise control pause switch. After a speed has been set and the speed is then disengaged by using the cruise control pause switch, the ECM will seek the previous set speed when the resume switch is toggled. This assumes that the vehicle speed is above the “Low Cruise Control Speed Set Limit” for cruise control or the vehicle speed is below the “Idle/PTO Vehicle Speed Limit” for the idle and the PTO.

The following background information is related to this procedure:

The kickout switch refers to the switch that is used to exit the cruise control, the PTO, the fast idle, or the idle set speed.

The operation of the Caterpillar Electronic Engine cruise control is similar to the operation of the cruise controls that are installed in automobiles. The operation of idle fast idle, and PTO are similar to the operation of cruise except that the idle, fast idle, and the PTO govern engine rpm instead of vehicle speed.

Note: Idle in this procedure is an engine idle rpm above the programmed low idle rpm. Idle is set by using the cruise control on/off switch and the set/resume switch. Refer to Troubleshooting, “PTO Switch Circuit - Test” for additional information regarding the programmable options for the dedicated PTO.

Kickout Switches

The service brake pedal position switches, the neutral switch and the clutch pedal position switch are used in the cruise control mode, the PTO mode, the fast idle mode, and the idle mode in order to discontinue cruise operation, PTO operation, fast idle operation, or idle operation. The capability to override the idle shutdown timer is determined by the “Allow Idle Shutdown Override” parameter setting. The “Allow Idle Shutdown Override” is a Customer Parameter.

Usage of Transmission Style Switches

The “Transmission Style” parameter determines the switches that will be used. The following switches can be used with being dependent on the parameter setting:

- clutch pedal position
- neutral
- service brake pedal position (switch 1)
- service brake pedal position (switch 2)

Refer to Table 161 for additional information.

Table 161

Setting For Transmission Style Parameter	Switch Usage.			
	Service Brake Switch 1	Service Brake Switch 2	Clutch	Neutral
“Manual Option 1”	X		X	
“Manual Option 2”	X	X	X	
“Automatic Option 1”	X			
“Automatic Option 2”	X	X		
“Automatic Option 3”	X	X		X
“Automatic Option 4”	X			X
“AT/MT/HT Option 1”	X			
“AT/MT/HT Option 2”	X	X		
“AT/MT/HT Option 3”	X	X		X
“AT/MT/HT Option 4”	X			X
“Universal Option”	X		X	X

If the “Transmission Style” parameter is programmed to one of the following options, the input for the clutch pedal position switch is not used.

- “Automatic Option 1”
- “Automatic Option 2”
- “Automatic Option 3”
- “Automatic Option 4”
- “AT/MT/HT Option 1”
- “AT/MT/HT Option 2”
- “AT/MT/HT Option 3”
- “AT/MT/HT Option 4”

A service brake pedal position (switch 1) is required for all configurations. The service brake pedal position (switch 1) connects to the ECM through connector P1 terminal 45. The service brake pedal position (switch 2) connects to the ECM through connector P1 terminal 64. The clutch pedal position switch connects to the ECM through connector P1 terminal 22. The neutral switch connects to the ECM through connector P1 terminal 62.

Some engines that were built before JULY 1999 may have a Basic ECM. The Basic ECM was used only on General Motors chassis. Other chassis used engines that were built with a Full Feature ECM. Basic ECM software does not have the parameter for "Transmission Style". For these systems, a jumper wire must be installed between the clutch switch input and the sensor common when an automatic transmission is installed. When the jumper wire is installed, the "Clutch Switch" status will always indicate "OFF". Engines that were built after JULY 1999 use only one type of ECM that can be configured for "Basic" or "Full Feature" operation. A new parameter was added in order to provide this flexibility. The "Truck Manufacturer" parameter was added in order to allow the configuration of the "GM Basic" operation or the "Other Full Feature" operation. This parameter is programmed at Caterpillar when the engine is built. The parameter for "Transmission Style" is not available for engines that have software that is dated prior to SEP00 and the parameter for "Truck Manufacturer" is programmed to "GM". SEP00 and newer engines that are programmed to "GM" use the "Transmission Style" parameter. The factory default for the "GM" setting is the "Universal" option. The "Universal" option provides identical features as the "Basic" system that is described above. If the "Transmission Style" parameter is programmed to the "Universal" option, a jumper wire must be installed between the clutch switch input and the sensor common when an automatic transmission is installed. Otherwise, the "Transmission Style" parameter can be programmed to match the specific arrangement of the vehicle.

This parameter is blank when the ECM is first powered up. If this parameter is blank, "No Occurrence" is indicated. This parameter remains blank until the ECM detects the use of the Cruise/Idle/PTO Mode. Also, this parameter remains blank until the ECM detects the disengagement of the Cruise/Idle/PTO Mode. Refer to Tables 162, 163, 164, and 165 in order to interpret the status screen kickout status parameter.

If the problem is with undetermined Cruise/Idle/PTO kickouts use the following procedure:

Operate the vehicle in "Cruise/Idle/PTO" mode.

After the kickout, review the status parameter on ET. The status parameter on ET indicates the cause. This must be performed before the ignition key switch is turned OFF. It is important to remember that the parameter will only indicate the last kickout since the ECM has been powered by the input for the ignition key switch.

The following kickout status parameters are available:

- "Cruise Kickout"
- "Idle Kickout"
- "PTO Kickout"
- "Fast Idle Kickout"

Table 162

Cruise Control Kickout Status Table		
ET	Meaning or Possible Cause	Troubleshooting
“Vehicle Speed >=Limit”	Intermittent vehicle speed signal or lost vehicle speed signal.	Refer to Troubleshooting, “Vehicle Speed Circuit - Test”.
“Switch Turned Off”	The cruise/idle on/off switch is turned off or the switch circuit has an open circuit condition.	Proceed with the test procedure.
“Cruise Control PAUSE Switch”	The cruise control pause switch is depressed or there is an illegal message on the J1939 data link.	Refer to Troubleshooting, “Powertrain Data Link Circuit - Test”.
“Brake Pedal Depressed”	The service brake pedal is depressed or the service brake switch circuit has an open circuit condition.	Refer to Troubleshooting, “Service Brake Pedal Position (Switch 1) Circuit - Test”.
“ClutchPedal Depressed”	The clutch pedal is depressed or the clutch pedal switch circuit has an open circuit condition. Also, the switch could be incorrectly adjusted.	Refer to Troubleshooting, “Clutch Pedal Position Switch Circuit - Test”.
“Neutral”	The transmission is not in gear or the transmission switch circuit has a short circuit condition.	Refer to Troubleshooting, “Neutral Switch Circuit - Test”.
“Bad Vehicle Speed”	Vehicle speed signal is erratic or intermittent.	Refer to Troubleshooting, “Vehicle Speed Circuit - Test” if a problem with the signal exists.
“PTO Switch On”	The PTO on/off switch is turned on or the circuit for the PTO on/off switch has a short circuit condition.	Refer to Troubleshooting, “PTO Switch Circuit - Test”.
Set Switch Timeout	The set/resume switch was held in the SET position for more than 15 seconds (Basic) or there is a short circuit in the switch circuit.	Cruise control cannot be set until the cruise control on/off switch is turned to the OFF position and then turned back to the ON position. If the circuit for the set switch is suspected, proceed with this test procedure.
Resume Switch Timeout	The set/resume switch was held in the SET position for more than 15 seconds (Basic) or there is a short circuit in the switch circuit.	Cruise control cannot be set until the cruise control on/off switch is turned to the OFF position and then turned back to the ON position. If the circuit for the resume switch is suspected, proceed with this test procedure.
“No Occurrence” or “Not Kicked Out”	Cruise control has not been enabled since the ECM has been powered up.	Drive the vehicle in cruise in order to create the problem again.

Table 163

Idle Kickout Status Table		
ET	Meaning or Possible Cause	Troubleshooting
“No Engine Speed”	Intermittent engine speed signal or lost engine speed signal.	Refer to Troubleshooting, “Engine Speed/Timing Circuit - Test”.
“Switch Turned Off”	The cruise/idle on/off switch is turned off or the switch circuit has an open circuit condition.	Proceed with the test procedure.
“Cruise Control PAUSE Switch”	The cruise control pause switch is depressed or there is an illegal message on the J1939 data link.	Refer to Troubleshooting, “Powertrain Data Link Circuit - Test”.
“Brake Pedal Depressed”	The service brake pedal is depressed or the service brake switch circuit has an open circuit condition.	Refer to Troubleshooting, “Service Brake Pedal Position (Switch 1) Circuit - Test”.
“Clutch Pedal Depressed”	The clutch pedal is depressed or the clutch pedal switch circuit has an open circuit condition. Also, the switch could be incorrectly adjusted.	Refer to Troubleshooting, “Clutch Pedal Position Switch Circuit - Test”.
“Vehicle Speed \geq Limit”	The vehicle speed has exceeded the Idle Vehicle Speed Limit or the vehicle speed signal is erratic or intermittent.	Refer to Troubleshooting, “Vehicle Speed Circuit - Test” if a problem with the signal exists.
“Neutral”	The transmission is not in neutral or the transmission neutral switch circuit has an open circuit condition.	Refer to Troubleshooting, “Neutral Switch Circuit - Test”.
“PTO Switch On”	The PTO on/off switch is turned on or the circuit for the PTO on/off switch has a short circuit condition.	Refer to Troubleshooting, “PTO Switch Circuit - Test”.
“No Occurrence” or “Not Kicked Out”	Idle set speed has not been enabled since the ECM has been powered up.	Operate the vehicle in the Idle mode in order to create the problem again.

Table 164

Fast Idle Kickout Status Table		
ET	Meaning or Possible Cause	Troubleshooting
“No Engine Speed”	Intermittent engine speed signal or lost engine speed signal.	Refer to Troubleshooting, “Engine Speed/Timing Circuit - Test”.
“Switch Turned Off”	The fast idle on/off switch is turned off or the switch circuit has an open circuit condition.	Proceed with the test procedure.
“Cruise Control PAUSE Switch”	The cruise control pause switch is depressed or there is an illegal message on the J1939 data link.	Refer to Troubleshooting, “Powertrain Data Link Circuit - Test”.
“Brake Pedal Depressed”	The service brake pedal is depressed or the service brake switch circuit has an open circuit condition.	Refer to Troubleshooting, “Service Brake Pedal Position (Switch 1) Circuit - Test”.
“Clutch Pedal Depressed”	The clutch pedal is depressed or the clutch pedal switch circuit has an open circuit condition. Also, the switch could be incorrectly adjusted.	Refer to Troubleshooting, “Clutch Pedal Position Switch Circuit - Test”.
“Vehicle Speed ≥ Limit”	The vehicle speed has exceeded the Idle Vehicle Speed Limit or the vehicle speed signal is erratic or intermittent.	Refer to Troubleshooting, “Vehicle Speed Circuit - Test” if a problem with the signal exists.
“Neutral”	The transmission is not in neutral or the transmission neutral switch circuit has an open circuit condition.	Refer to Troubleshooting, “Neutral Switch Circuit - Test”.
“No Occurrence” or “Not Kicked Out”	Fast idle set speed has not been exited since the ECM has been powered up.	Operate the vehicle in the Idle mode in order to create the problem again.

Table 165

Table For The PTO Kickout Status Screen On ET		
ET	Meaning or Possible Cause	Troubleshooting
No Engine Speed	Intermittent engine speed signal or lost engine speed signal.	Refer to Troubleshooting, "Speed/Timing Circuit - Test".
Switch Turned Off	The PTO On/Off switch is turned OFF or the switch circuit has an open circuit condition.	Proceed with the test procedure.
"Cruise Control PAUSE Switch"	The cruise control pause switch is depressed or there is an illegal message on the J1939 data link.	Refer to Troubleshooting, "Powertrain Data Link Circuit - Test".
"Brake Pedal Depressed"	The service brake pedal is depressed or the service brake switch circuit has an open circuit condition.	Refer to Troubleshooting, "Service Brake Pedal Position Switch 1 Circuit - Test".
"Clutch Pedal Depressed"	The clutch pedal is depressed or the clutch pedal switch circuit has an open circuit condition. Also, the switch could be incorrectly adjusted.	Refer to Troubleshooting, "Clutch Pedal Position Switch Circuit - Test".
Vehicle Speed ≥ Limit	The vehicle speed has exceeded the PTO Vehicle Speed Limit or the vehicle speed signal is erratic or intermittent.	Refer to Troubleshooting, "Vehicle Speed Circuit - Test" if a problem with the signal exists.
Neutral	The transmission is not in neutral or the transmission neutral switch circuit has an open circuit condition.	Refer to Troubleshooting, "Neutral Switch Circuit - Test".
"No Occurrence" or "Not Kicked Out"	The PTO has not been enabled since the ECM has been powered up.	Operate the vehicle in the PTO mode in order to create the problem again.

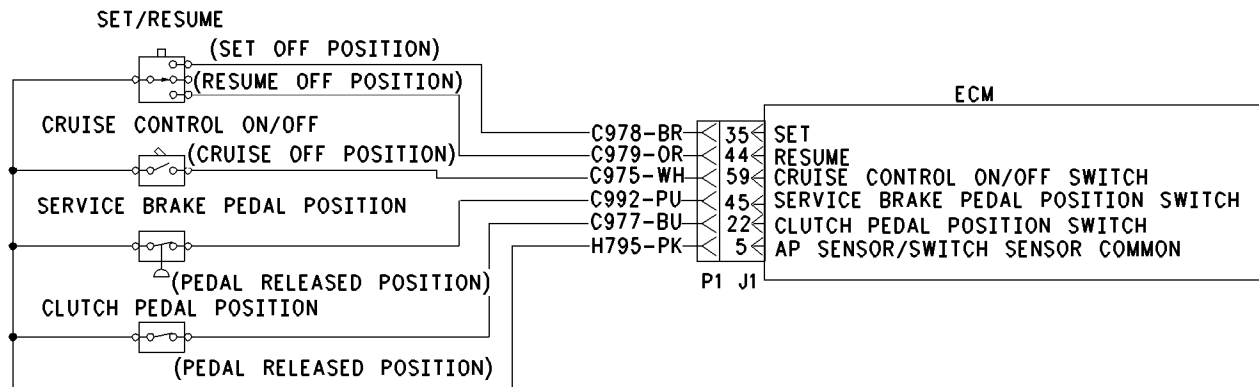

Illustration 74

g00643881

Schematic for cruise control switch, service brake pedal position switch 1 and clutch pedal position switch

Test Step 1. Determine the Type of Problem.

A. Connect ET.

B. Turn the ignition key switch to the ON position.

C. If the vehicle will not allow setting a cruise speed, an idle speed or a PTO speed, check the following Customer Parameters:

Cruise Control Parameters

- “Low Cruise Control Speed Set Limit”
- “High Cruise Control Speed Set Limit”

Idle Parameters

- “Fast Idle RPM #1”
- “Fast Idle RPM #2”
- “Idle Vehicle Speed Limit”
- “Idle rpm Limit”
- “Top Engine Limit (TEL)”

PTO Parameters

- “PTO Configuration”
- “PTO Vehicle Speed Limit”

- D.** Ensure that the vehicle is not experiencing a problem due to one of these parameters. Refer to Troubleshooting, “Customer Specified Parameters” for a description of the parameters, if necessary.
- E.** Check the status screen that indicates the last cause of a kickout for one of the following items:
- Cruise Control Kickout
 - Idle Kickout
 - Fast Idle Kickout
 - PTO Kickout

Refer to Tables 162, 163, 164, and 165 for the meaning of the cause of the kickout.

Expected Result:

The problem is due to a parameter setting or the problem is due to a normal kickout.

Results:

- **Yes** – Explain the proper operation of system to the driver. **STOP.**
- **No**

Repair: Refer to Tables 162, 163, 164, and 165 for recommended troubleshooting.

If a problem is still suspected with the cruise control on/off switch or the set/resume switch, perform the following procedure:

Proceed to Test Step 2.

Test Step 2. Inspect Electrical Connectors and Wiring.

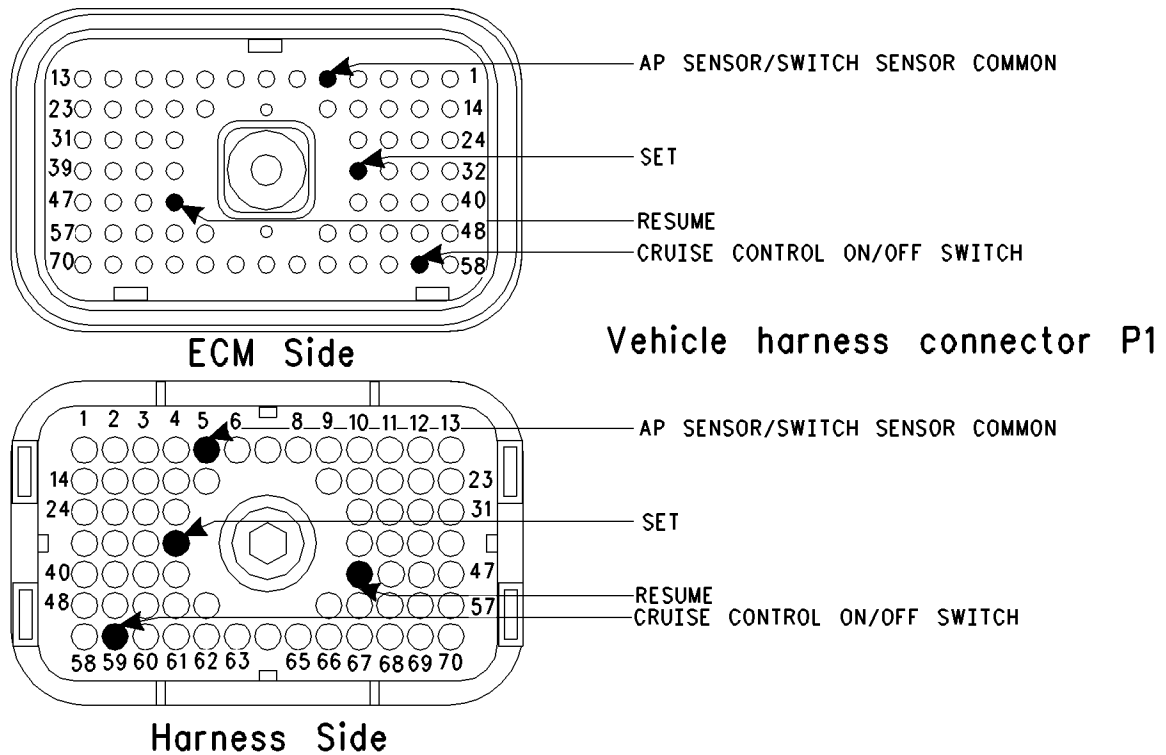

Illustration 75

g00703076

A. Thoroughly inspect ECM vehicle harness connector J1/P1, the firewall bulkhead connector and the terminals for the following switches in the connectors:

- AP sensor/switch sensor common (terminal 5)
- set/resume switch (terminals 35 and 44)
- cruise control on/off switch (terminal 59)

Refer to Troubleshooting, "Electrical Connectors - Inspect" for details.

B. Perform a 45 N (10 lb) pull test on each of the wires in the ECM connector that are associated with the switches.

Refer to Illustration 75.

C. Check the ECM connector (allen head screw) for the proper torque of 6.0 N·m (55 lb in).

D. Check the harness and wiring for abrasion and pinch points from the sensor to the ECM.

Expected Result:

All connectors, pins and sockets should be completely coupled and/or inserted and the harness and wiring should be free of corrosion, abrasion or pinch points.

Results:

- OK – Proceed to Test Step 3.
- Not OK

Repair: Repair the connectors or wiring and/or replace the connectors or wiring. Ensure that all of the seals are properly in place and ensure that the connectors are completely coupled.

Verify that the repair eliminates the problem.

STOP.

Test Step 3. Check the Cruise Control Switch Status on ET.

Table 166

Table for Cruise Control Switch Status		
Switch Position	Switch Status	Circuit
The Cruise/Idle On/Off Switch is turned ON.	ON	Closed
The Cruise/Idle On/Off Switch is turned OFF.	OFF	Open
The Set/Resume Switch is in the SET position.	Set Switch ON	Closed
The Set/Resume Switch is in the RESUME position.	Resume Switch ON	Closed

- A. Access the status screen on ET.
- B. Turn the ignition key switch to the ON position.
- C. Operate the cruise control on/off switch while the status of the cruise/idle on/off switch is being observed.
- D. Leave the cruise control on.
- E. Operate the set switch while the status of the set/resume switch is being observed. The status screen should indicate "Set Switch ON" when the set switch is held in the SET position. The status screen should indicate "Off" when the set switch is released.
- F. Operate the resume switch while the status of the resume switch is being observed. The status screen should indicate "Resume Switch ON" when the resume switch is held in the RESUME position. The status screen should indicate "Off" when the resume switch is released.

Expected Result:

The switch status changes per the information in Table 166.

Results:

- **Yes** – The switches are operating normally. STOP.
- **Intermittent Problem Suspected** – Proceed to Test Step 4.
- **No** – The ECM is not reading the switch status change. Proceed to Test Step 5.

Test Step 4. Operate the Vehicle and Check the Kickout Status Parameter.

- A. For an intermittent cruise control kickout, talk to the driver in order to determine the conditions when the kickout occurs. Topics of examination could be the following examples:

- specific speed
- road conditions
- weather conditions

Take the vehicle for a road test in order to duplicate these conditions and set the cruise control. Operate the vehicle in cruise control until the problem reoccurs.

- B. For an intermittent idle kickout, talk to the driver in order to determine the conditions when the kickout occurs. A topic of examination could be the following example:

- specific engine rpm

Start the engine. Duplicate these conditions and set the idle rpm. Operate the vehicle in idle until the problem reoccurs.

Note: The status screen will only indicate the last kickout. The status screen will lose this information if the ignition key switch is turned OFF.

- C. Connect ET and check the status screen for the last cause of the kickout. Refer to Tables 162, 163, 164, and 165 for an explanation of the status parameter.
- D. If the status screen is blank, then either there was no kickout of the cruise control, or the power to the ECM was turned OFF before the information could be read. Repeat this test step.

Note: A status screen that is blank indicates No Occurrence.

Expected Result:

RESULT 1 The status screen displays the following result:

- "Switch Turned Off"

RESULT 2 The status screen displays the following result:

- "Cruise Control PAUSE Switch"

RESULT 3 The status screen displays the following results:

- "Vehicle Speed < Limit"

- “Bad Vehicle Speed”
- “Vehicle Speed \geq Limit”

RESULT 4 The status screen displays the following result:

- “PTO Switch ON”

RESULT 5 The status screen displays the following result:

- “Neutral”

RESULT 6 The status screen displays the following result:

- “Brake”

RESULT 7 The status screen displays the following result:

- “Clutch”

RESULT 8 The status screen displays the following result:

- “No Engine Speed”

RESULT 9 The status screen displays the following result:

- “Set Switch Timeout”
- “Resume Switch Timeout”

Results:

- **RESULT 1** – Proceed to Test Step 5.

- **Result 2**

Repair: Perform the following diagnostic procedure:

Troubleshooting, “Powertrain Data Link Circuit - Test”

STOP.

- **Result 3**

Repair: Perform the following diagnostic procedure:

Troubleshooting, “Vehicle Speed Circuit - Test”

STOP.

- **Result 4**

Repair: Perform the following diagnostic procedure:

Troubleshooting, “PTO Switch Circuit - Test”

STOP.

- **Result 5**

Repair: Perform the following diagnostic procedures:

Troubleshooting, “Neutral Switch Circuit - Test”.

STOP.

- **Result 6**

Repair: Perform the following diagnostic procedure:

Troubleshooting, “Service Brake Pedal Position (Switch 1) Circuit - Test”

STOP.

- **Result 7**

Repair: Perform the following diagnostic procedure:

Troubleshooting, “Clutch Pedal Position Switch Circuit - Test”

STOP.

- **Result 8**

Repair: Perform the following diagnostic procedure:

Troubleshooting, “Engine Speed/Timing Switch Circuit - Test”

STOP.

- **Result 9**

Repair: Perform the following diagnostic procedure:

Troubleshooting, “Cruise Control Switch Circuit - Test”

STOP.

Test Step 5. Check the Switch Circuit.

Table 167

Table for Status of the Cruise Control Switch Input		
Condition of Switch Circuit	Switch Status	Circuit
Terminal 59 Cruise/Idle On/Off Switch is Open.	OFF	Open
Terminal 59 Cruise/Idle On/Off Switch is connected to terminal 5.	ON	Shorted
Set Switch Terminal 35 is Open.	OFF	Open
Set Switch Terminal 35 connected to terminal 5.	Set Switch ON	Shorted
Resume Switch (Terminal 44) is Open.	OFF	Open
Resume Switch (Terminal 44) connected to terminal 5.	Resume Switch ON	Shorted

- A.** Turn the ignition key switch to the OFF position.
 - B.** Fabricate a jumper wire 100 mm (4 inch) long. Crimp a Deutsch pin to both ends of the wires.
 - C.** Disconnect vehicle harness connector P1 from the ECM.
 - D.** Connect a breakout T to ECM connector J1 and connect P1 to the breakout T.
 - E.** Install the jumper into the suspect switch socket of the breakout T. Connect the other end of the jumper to ECM connector P1 terminal 5 (ap sensor/switch sensor common) of the breakout T.
 - F.** Turn the ignition key switch to the ON position.
 - G.** Connect ET to the cab data link connector.
 - H.** Access the status screen.
 - I.** While the switch status is being monitored on the status screen slowly remove the jumper from terminal 5 and slowly insert the jumper from terminal 5 (ap sensor/switch sensor common).
- 3.** Recheck the system for active diagnostic codes.
 - 4.** Repeat the test step.
 - 5.** If the problem is resolved with the test ECM, reconnect the suspect ECM.
 - 6.** If the problem returns with the suspect ECM, replace the ECM.
 - 7.** Verify that the repair eliminates the problem.

STOP.

Refer to Table 167.

Expected Result:

The switch status changes per the information in Table 167.

Results:

- **Yes** – The ECM is functioning properly. Proceed to Test Step 6.
- **No** – The ECM is not functioning properly.

Repair: Perform the following repair:

- 1.** Temporarily connect a test ECM.
- 2.** Remove all jumpers and replace all connectors.

Test Step 6. Insert a Jumper at the Suspect Switch.

Table 168

Table for Status of the Cruise Control Switch Input		
Condition of Switch Circuit	Switch Status	Circuit
The wires for the Cruise/Idle On/Off Switch are disconnected.	OFF	Open
The wires for the Cruise/Idle On/Off Switch are connected.	ON	Shorted
Set Switch wires are disconnected.	OFF	Open
Set Switch wires are connected.	Set Switch ON	Shorted
The Resume Switch wires are disconnected.	OFF	Open
The Resume Switch wires are connected.	Resume Switch ON	Shorted

- A.** Turn the ignition key switch to the OFF position.
- B.** Ensure that ECM vehicle harness connector J1/P1 is connected.
- C.** Find the suspect switch in the vehicle.
- D.** Disconnect the wires from the suspect switch terminals.
- E.** Turn the ignition key switch to the ON position.
- F.** Connect ET to the cab data link connector.
- G.** Access the status screen.
- H.** While the switch status is being monitored on the status screen slowly connect the suspect switch wires and slowly disconnect the suspect switch wires.

Refer to Table 168.

Expected Result:

The switch status changes per the information in Table 168.

Results:

- Yes

Repair: Perform the following repair:

Replace the faulty switch.

Verify that the repair eliminates the problem.

STOP.

- No – There is a problem in the harness between the switch and the ECM. Proceed to Test Step 7.

Test Step 7. Insert a Jumper at the Bulkhead Connector.

Table 169

Table for Status of the Cruise Control Switch Input		
Condition of Switch Circuit	Switch Status	Circuit
The wires for the Cruise/Idle On/Off Switch are disconnected.	OFF	Open
The wires for the Cruise/Idle On/Off Switch are connected.	ON	Shorted
The Set Switch wires are disconnected.	OFF	Open
The Set Switch wires are connected.	Set Switch ON	Shorted
The Resume Switch wires are disconnected.	OFF	Open
The Resume Switch wires are connected.	Resume Switch ON	Shorted

- A. Turn the ignition key switch to the OFF position.
- B. Fabricate a jumper wire 100 mm (4 inch) long. Crimp a Deutsch pin to both ends of the wires.
- C. Find the suspect switch terminal and the ap sensor/switch sensor Common terminal in the engine side of the bulkhead connector for the vehicle harness.
- D. Insert the jumper wire between the two terminals in the engine side of the bulkhead connector.
- E. Turn the ignition key switch to the ON position.
- F. Connect ET to the cab data link connector.
- G. Access the status screen.
- H. While the switch status is being monitored on the status screen alternately remove the jumper wire between the two terminals, and alternately insert the jumper wire between the two terminals.

Refer to Table 169.

Expected Result:

The switch status changes per the information in Table 169.

Results:

- **Yes** – The problem is in the vehicle wiring between the bulkhead connector and the switch.

Repair: Perform the following repair:

Inspect the vehicle wiring and repair the vehicle wiring, as required. If the problem still exists with the wiring, send the vehicle to the OEM dealer.

STOP.

- **No** – The problem is in the vehicle wiring between the bulkhead connector and the ECM.

Repair: Perform the following repair:

Inspect the vehicle wiring and repair the vehicle wiring, as required. If the problem still exists with the wiring, send the vehicle to the OEM dealer.

STOP.

i01631916

ECM Memory - Test

SMCS Code: 1901-081

System Operation Description:

Use this procedure under the following situation:

Use this procedure if one of the following diagnostic codes is present:

- 252-11 Incorrect Engine Software (59)
- 253-02 Check Customer or System Parameters (56)
- 253-14 Truck Manufacturer Parameter Not Programmed (56)

Also, use this procedure if the integrity of the Customer Parameters or the System Parameters in the ECM is questionable. Also, use this procedure if the data for the Engine Lifetime Totals is questionable.

The following background information is related to this procedure:

The Engine Control Module (ECM) is the computer which controls the Caterpillar electronic truck engine. The Personality Module contains the software that controls the operation of the computer (ECM).

The Personality Module software is the instructions that are used by the ECM to control the engine. For this reason, updating the Personality Module to a different version may cause some engine functions to behave in a different manner.

Performance Maps

Performance Maps define characteristics for various operating conditions. These characteristics are used to achieve optimum performance while emissions requirements are being met. Examples of these characteristics are included in the following list:

- Fuel rate
- Timing

These characteristics are programmed into the Personality Module at the factory only.

Microprocessor

The ECM uses a microprocessor to perform the computing that is required to perform the following functions:

- Governing
- Controlling timing
- Generating diagnostic codes
- Communicating with service tools

The microprocessor reads the instructions from the software in the Personality Module.

Programmable Parameters

Programmable Parameters are stored in permanent memory. This includes both Customer Specified Parameters and System Configuration Parameters. Refer to Troubleshooting, "Customer Specified Parameters" for details on Customer Specified Parameters and refer to Troubleshooting, "System Configuration Parameters" for details on System Configuration Parameters.

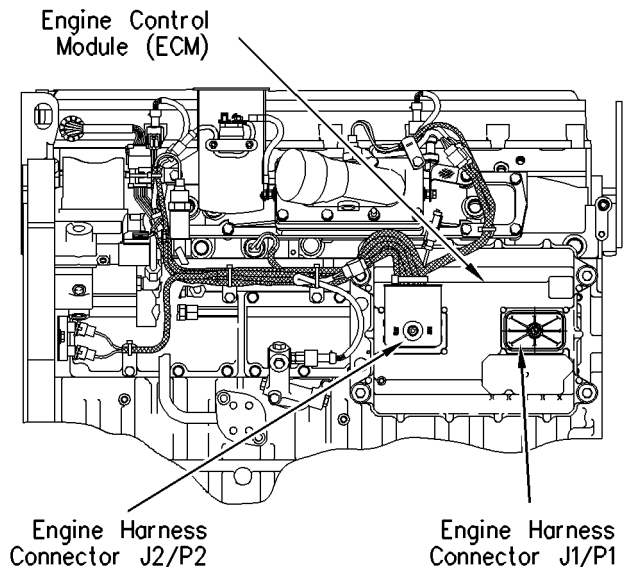

Illustration 76
ECM and harness connectors

g00772334

Logged Diagnostics

Logged diagnostics are stored by the ECM into memory so a permanent record of the diagnostic code is retained. Logged faults that are not critical are automatically cleared after 100 hours.

Input Circuits

Input circuits filter electrical noise for sensor signals. Also, input circuits protect internal circuits from potentially damaging voltage levels.

Output Circuits

Output circuits provide the voltage or current that is required to energize components that are connected to the ECM.

Power Circuits

Power circuits provide clean stable electrical power to internal circuits and external sensors.

Test Step 1. Inspect Electrical Connectors and Wiring.

- Thoroughly inspect ECM vehicle harness connector J1/P1 and the battery connections. Refer to Troubleshooting, "Electrical Connectors - Inspect" for details.
- Perform a 45 N (10 lb) pull test on each of the following wires in the ECM connector:
 - Ignition key switch (terminal 70)

- +Battery (terminals 52 and 53)
- –Battery (terminals 65 and 67)
- ATA data link (terminals 8 and 9)

C. Check the ECM connector (allen head screw) for the proper torque of 6.0 N·m (55 lb in).

D. Check the harness and wiring for abrasion and pinch points from the data link connectors back to the ECM.

Expected Result:

All connectors, pins and sockets should be completely coupled and/or inserted and the harness and wiring should be free of corrosion, abrasion or pinch points.

Results:

- OK – Proceed to Test Step 2.
- Not OK

Repair: Repair the connectors or wiring and/or replace the connectors or wiring. Ensure that all of the seals are properly in place and ensure that the connectors are completely coupled.

Verify that the repair eliminates the problem.

STOP.

Test Step 2. Check for Diagnostic Codes.

Connect ET and check for diagnostic codes.

Expected Result:

Result 1 The following diagnostic code requires troubleshooting:

- 252-11 Incorrect Engine Software (59)

Result 2 The following diagnostic code requires troubleshooting:

- 253-02 Check Customer or System Parameters (56)

Result 3 Scrambled parameters or data require troubleshooting.

Result 4 The following diagnostic code requires troubleshooting:

- 253-14 Truck Manufacturer Programmed Not Programmed (6)

Results:

- **Result 1** – Proceed to Test Step 3.
- **Result 2** – Proceed to Test Step 4.
- **Result 3** – Proceed to Test Step 5.
- **Result 4** – Proceed to Test Step 6.

Test Step 3. Use ET To Check The Part Number Of The ECM Personality Module.

A. Connect ET at the cab data link connector.

B. Turn the ignition key switch to the ON position.

C. Read the Customer Specified Parameters. Refer to Troubleshooting, “Programming Parameters”.

D. Ensure that the Personality Module Part Number agrees with the original engine arrangement.

Expected Result:

The correct Personality Module is installed in the ECM for the engine.

Results:

- Yes

Repair: The diagnostic code 252-11 must be cleared if the correct Personality Module has been installed. Clearing this diagnostic code requires Factory Passwords and resetting the Personality Module Code to zero.

STOP.

- No

Repair: Reprogram the ECM with the correct Personality Module. Refer to Troubleshooting, “Flash Programming”.

Verify that the repair eliminates the problem.

STOP.

Test Step 4. Use ET to Determine Parameters that Require Programming.

A. Connect ET at the cab data link connector.

B. Turn the ignition key switch to the ON position.

C. Check the active diagnostic codes. Note any parameters that are listed in the following active diagnostic code:

- 253-02 Check Customer or System Parameters (56)

Expected Result:

The ECM allows the parameters that are listed under the following active diagnostic code in the “Active Diagnostic Code” screen to be programmed:

- 253-02 Check Customer or System Parameters (56)

Results:

- Yes

Repair: Ensure that the cause of all diagnostic codes is repaired.

STOP.

- No

Repair: Temporarily connect a test ECM. Ensure that the test ECM will allow the programming of the Parameters. If the test ECM does not allow the programming of the Parameters, the old ECM is OK. Something is wrong in the vehicle wiring. Check the battery supply circuit to the ECM and repair, as required.

Verify that the repair eliminates the problem.

STOP.

Test Step 5. Use ET to Review Parameters and Data.

- A.** Turn the ignition key switch to the ON position.
- B.** Check the active diagnostic codes and the logged diagnostic codes by using ET.
- C.** Review the Customer and System Parameters.
- D.** Review the Engine Lifetime Totals.

Expected Result:

The parameters and totals are scrambled.

Results:

- Yes

Repair: Try to reprogram the suspect parameter or parameters. If the ECM does not maintain the parameters, temporarily connect a test ECM. Ensure that the test ECM will allow the programming of the parameters. If the test ECM does not allow the programming of the parameters, the old ECM is OK. Something is wrong in the vehicle wiring. Check the battery supply circuit to the ECM and repair, as required.

Verify that the repair eliminates the problem.

STOP.

- No – The ECM is OK. STOP.

Test Step 6. Use ET to Determine Programming Requirements

A. Connect ET to the cab data link connector.

B. Turn the ignition key switch to the ON position.

C. Check for active diagnostic codes.

Note: If the diagnostic code 253-14 is active, the “Truck Manufacturer” parameter must be programmed.

D. Determine the type of chassis. If the engine is installed in a General Motors chassis, program the “Truck Manufacturer” parameter to GM. For any other chassis, program the parameter to “Other”.

Note: ET will indicate that the communication to the ECM must be reestablished in order for the change in the parameter to take effect.

Expected Result:

There are no active diagnostic codes.

Results:

- Yes – Diagnostic codes are active. Proceed to the appropriate troubleshooting procedure for the active diagnostic code. STOP.
- No – The ECM has been properly programmed. STOP.

i01720712

Electrical Connectors - Inspect

SMCS Code: 1408-040-CY

System Operation Description:

Most electrical problems are caused by poor connections. The following procedure will assist in detecting problems due to connectors. If a problem is found in an electrical connector, repair the connector and verify that the problem does not return. Do NOT cut connector wires unless terminals are being replaced. Repair the connectors with a **1U-5804** Crimp Tool. The wedges on the DT connectors are easily removed with a **147-6456** Removal Tool.

Intermittent electrical problems often disappear by disconnecting and reconnecting connectors. It is very important to check for diagnostic codes immediately before disconnecting a connector. Also check for diagnostic codes after reconnecting any connectors. If the status of a diagnostic code is changed due to disconnecting and reconnecting a connector, there are several possible reasons. The likely problems are loose or improperly crimped terminals, moisture, corrosion, or connectors not mated securely.

ALWAYS crimp the terminals on the wires with the 1U-5804 Crimp Tool. Do not solder the terminals.

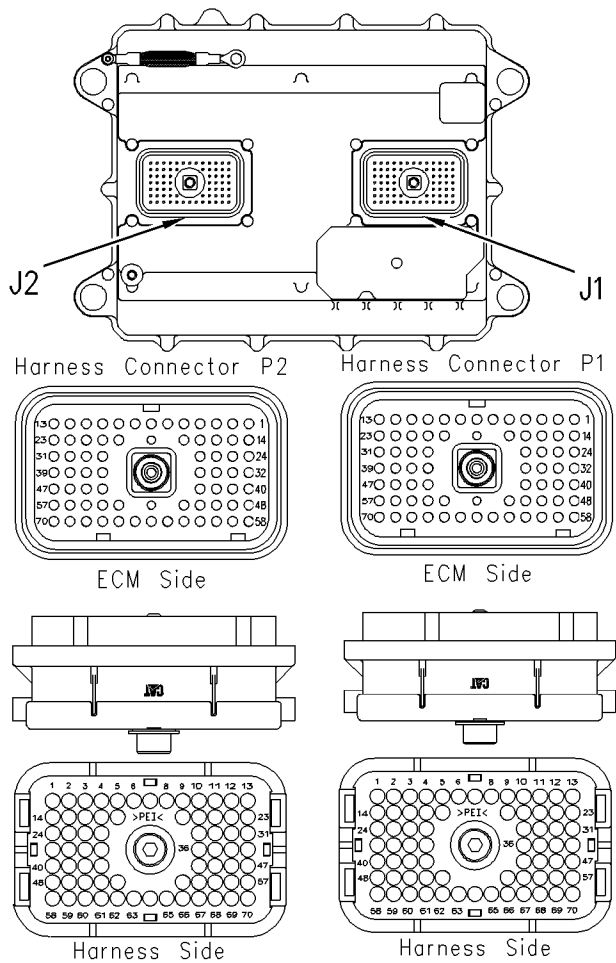

Illustration 77
ECM connectors (AMP)

g00693506

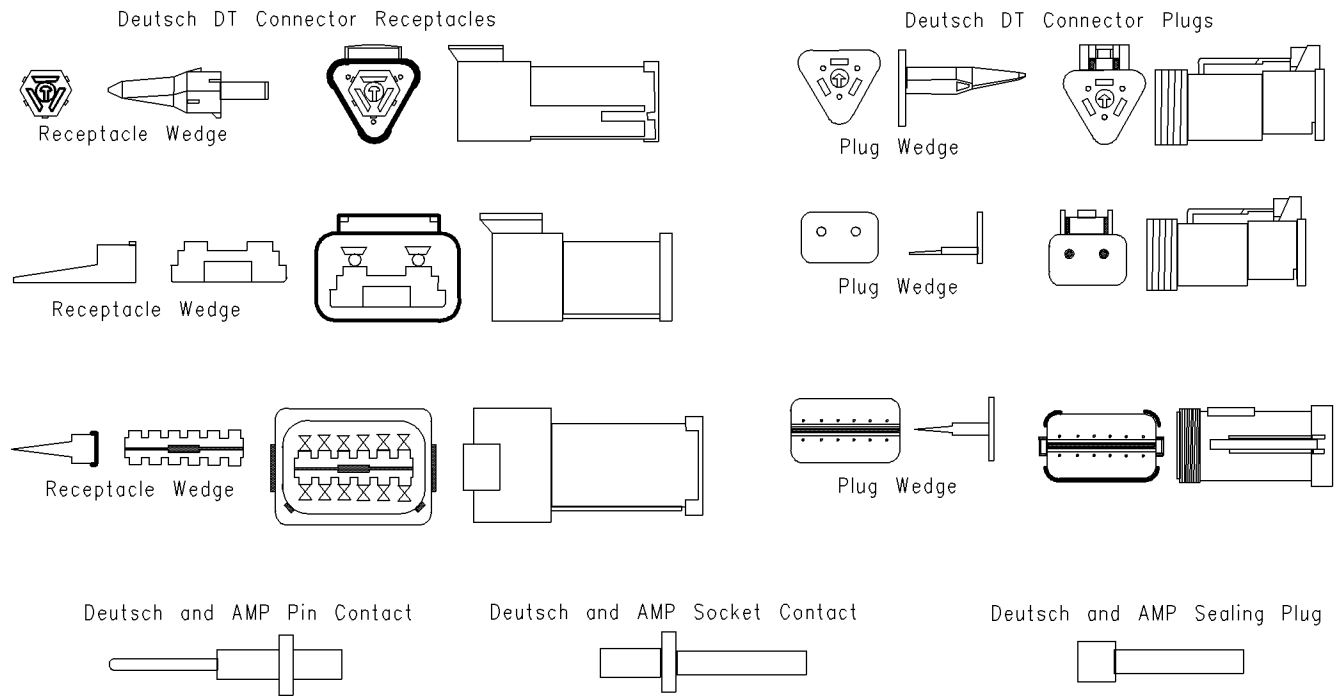

Illustration 78
Deutsch connector receptacles and plugs

g00675955

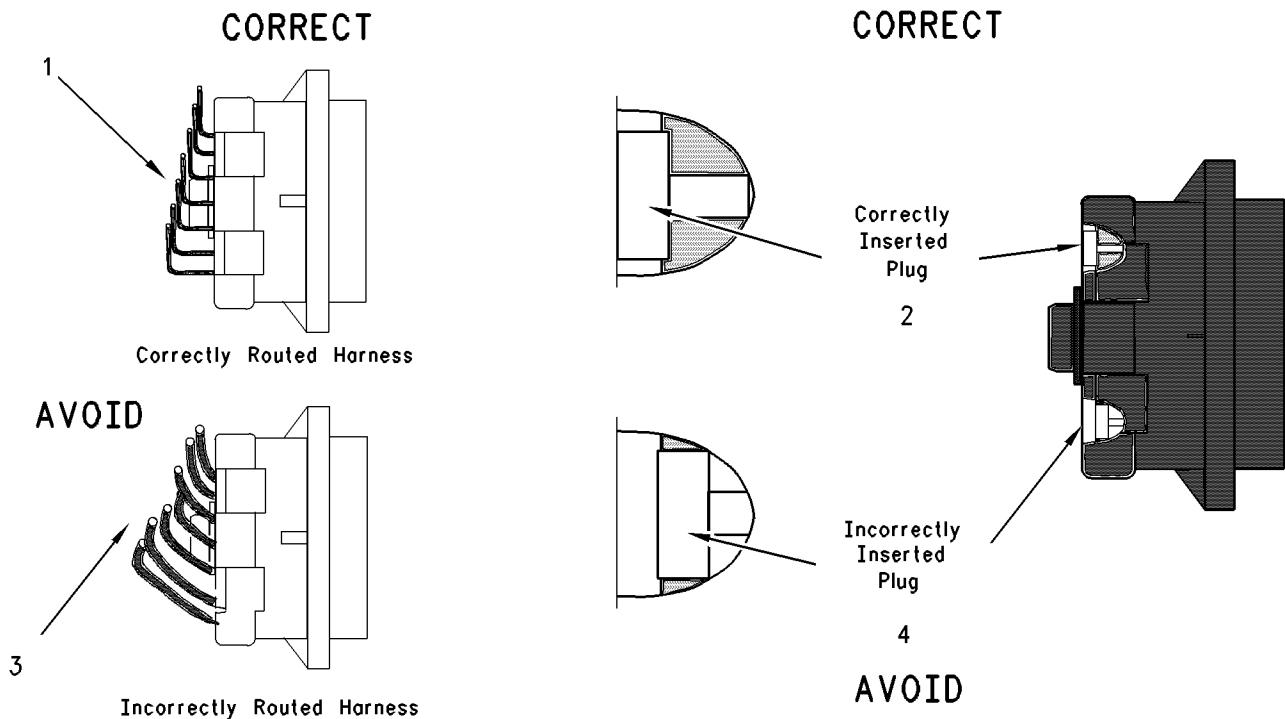

Illustration 79

g00640158

Routing of the Harness and insertion of the plug

- (1) Correctly routed harness
- (2) Correctly inserted plug
- (3) Incorrectly routed harness
- (4) Incorrectly inserted plug

Test Step 1. Check the Locking of the DT Connector (Deutsch) and Check the Lock Ring of the HD Style Connector (Deutsch)

- A.** Ensure that the connector is properly locked. Also ensure that the two halves of the connector can not be pulled apart.
- B.** Verify that the latch tab of the connector is properly latched. Also verify that the latch tab of the connector returns to the locked position.

Expected Result:

The connector will securely lock. The connector and the locking mechanism are without cracks or breaks.

Results:

- OK – Proceed to Test Step 2.
- Not OK

Repair: Repair the connector or replace the connector, as required.

Verify that the repair eliminates the problem.

STOP.

Test Step 2. Check the Allen Head Screw on the ECM Connector

- A.** Ensure that the allen head screw is properly tightened. Be careful not to overtighten the screw and break the screw.
- B.** Do not exceed 6.0 N·m (55 lb in) of torque on the allen head screw.

Expected Result:

The ECM connector is secure and the allen head screw is properly torqued.

Results:

- OK – Proceed to Test Step 3.
- Not OK

Repair: Repair the connector or replace the connector, as required.

Verify that the repair eliminates the problem.

STOP.

Test Step 3. Perform a Pull Test on Each Wire Terminal Connection

- A.** Each terminal and each connector should easily withstand 45 N (10 lb) of pull and each wire should remain in the connector body. This test checks whether the wire was properly crimped in the terminal and whether the terminal was properly inserted into the connector.
- B.** The DT connectors use a green wedge to lock the terminals in place. Ensure that the green wedge is not missing and that the green wedge is installed properly on the DT connectors.

Note: Terminals should always be crimped onto the wires by using a crimp tool. Do not solder terminals. Use the 1U-5804 Crimp Tool.

Expected Result:

Each terminal and each connector easily withstands 45 N (10 lb) of pull and each wire remains in the connector body.

Results:

- OK – Proceed to Test Step 4.
- Not OK

Repair: Repair the circuit.

Verify that the repair eliminates the problem.

STOP.

Test Step 4. Perform the “Wiggle Test” on Cat ET

- A.** Select the “Wiggle Test” from the diagnostic tests on Cat ET.
- B.** Press the “OK” button after you adhere to the warning.
- C.** Choose the appropriate group of parameters to monitor.
- D.** Press the “Start” button. Wiggle the wiring harness in order to reproduce intermittent problems.
- E.** If an intermittent problem exists, the status will be highlighted and an audible beep will be heard.

Expected Result:

No intermittent problems were indicated during the “Wiggle Test”.

Results:

- OK – Proceed to Test Step 5.
- Not OK

Repair: Repair the circuit.

Verify that the repair eliminates the problem.

STOP.

Test Step 5. Check Wires for Nicks or Abrasion in the Insulation

- A.** Carefully inspect each wire for signs of abrasion, nicks, or cuts.

The following areas are locations that should be checked:

- Exposed insulation
- Points of rubbing wire against the engine
- Points of rubbing wire against a sharp point

- B.** Check all of the hold down clamps for the harness in order to verify that the harness is properly clamped. Also check all of the hold down clamps for the harness in order to verify that the harness is not compressed by the clamp. Pull back the harness sleeves in order to check for a flattened portion of wire. The flattened portion of wire is caused by the clamp that holds the harness.

Expected Result:

The wires are free of abrasion, nicks, or cuts and the harness is properly clamped.

Results:

- OK – Proceed to Test Step 6.
- Not OK

Repair: Repair the wires or replace the wires, as required.

Verify that the repair eliminates the problem.

STOP.

Test Step 6. Check Connectors for Moisture or Corrosion

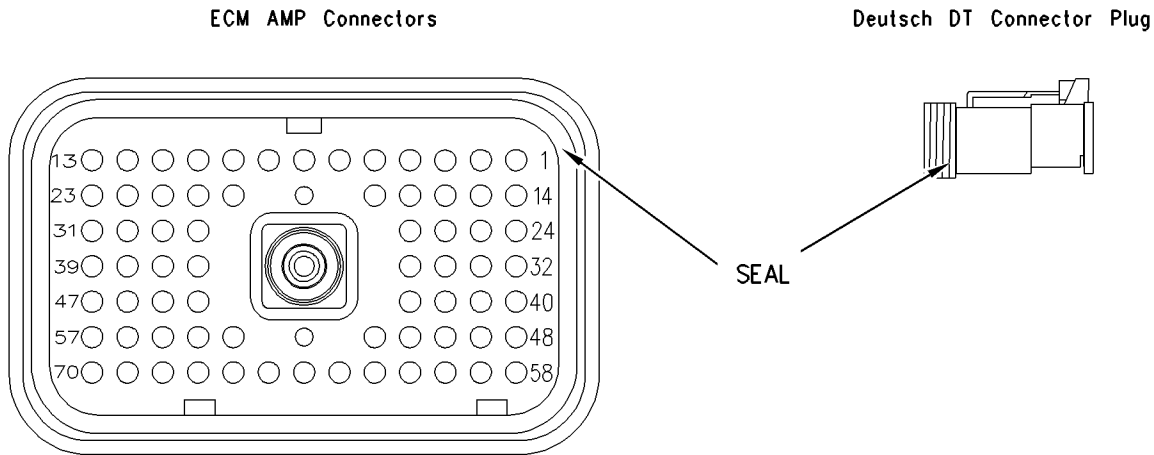

Illustration 80
Connector seals

g00705443

- A.** Ensure that the connector seals and the white sealing plugs are in place. If any of the seals or plugs are missing, replace the seal or plug. If necessary, replace the connector.
- B.** Check all of the wiring harnesses in order to verify that the harness does not make a sharp bend out of a connector. This will deform the connector seal and this will create a path for the entrance of moisture.

Thoroughly inspect the J1/P1 and J2/P2 ECM connectors for evidence of moisture entry.

Note: It is normal to see some minor seal abrasion on the ECM Connector seals. Minor seal abrasion will not allow the entry of moisture.

- C.** If moisture or corrosion is evident in the connector, the source of the moisture entry must be found and the source of the moisture entry must be repaired. If the source of the moisture entry is not repaired, the problem will reoccur. Simply drying the connector will not fix the problem. Likely paths for the entrance of moisture are illustrated in the following list:

- Missing seals
- Improperly installed seals
- Nicks in exposed insulation
- Improperly mated connectors

Moisture can also travel from one connector through the inside of a wire to the ECM Connector. If moisture is found in the ECM connector, thoroughly check all connectors and wires on the harness that connect to the ECM. The ECM is not the source of the moisture. Do not replace an ECM if moisture is found in either ECM connector.

Note: If corrosion is evident on the pins, sockets or the connector, use only denatured alcohol to remove the corrosion. Use a cotton swab or a soft brush to remove the corrosion. Do not use any cleaners that contain 1,1,1 trichloro-ethylene because 1,1,1 trichloro-ethylene may damage the connector.

Expected Result:

All of the connectors should be completely coupled and all of the seals should be completely inserted. The harness and the wiring should be free of corrosion, abrasion or pinch points.

Results:

- OK – Proceed to Test Step 7.
- Not OK

Repair: Repair the connectors or wiring and/or replace the connectors or wiring. Ensure that all of the seals are properly in place and ensure that the connectors are completely coupled.

Verify that the repair eliminates the problem by running the engine for several minutes and by checking again for moisture. If moisture reappears, the moisture is wicking into the connector. Even if the moisture entry path is repaired, it may be necessary to replace the wires that have moisture. These wires may have moisture that is trapped inside the insulation. Verify that the repair eliminates the problem.

STOP.

Test Step 7. Inspect the Connector Terminals

- A.** Verify that the terminals are not damaged. Verify that the terminals are properly aligned in the connector and verify that the terminals are properly located in the connector.

Expected Result:

The terminals are properly aligned and the terminals appear undamaged.

Results:

- OK – Proceed to Test Step 8.
- Not OK

Repair: Repair the terminals and/or replace the terminals, as required.

Verify that the repair eliminates the problem.

STOP.

Test Step 8. Check Individual Pin Retention into the Socket

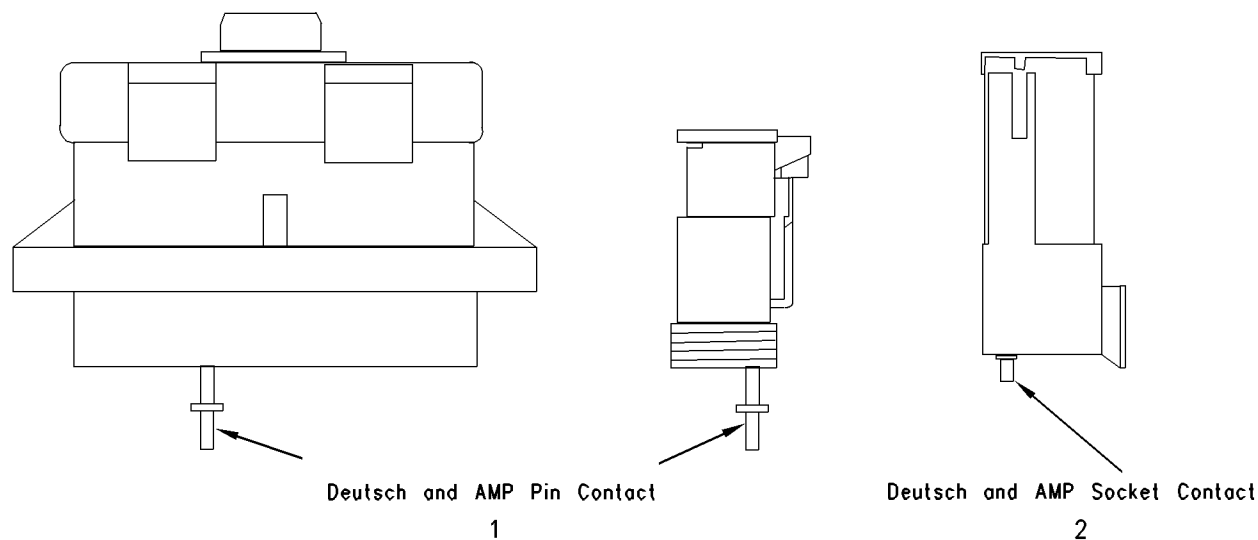

Illustration 81

g00640220

(1) Contact of the pin

(2) Contact of the socket

Note: This is especially important for intermittent problems.

i01606357

- A.** Use a new pin. Insert the pin into each socket one at a time in order to check for a good grip on the pin by the socket.
- B.** Use a new socket. Insert the socket over each pin one at a time in order to check for a good grip on the pin by the socket. The pins are located on the mating side of the connector.
- C.** The contact terminal should stay connected when the connector is held in the position shown in Illustration 81. The contact terminal is the pin or the socket.

Expected Result:

The pins and the sockets appear to be OK.

Results:

- OK – STOP.
- Not OK

Repair: Repair the terminals and/or replace the terminals.

Verify that the repair eliminates the problem.

STOP.

Engine Pressure Sensor Open or Short Circuit - Test

SMCS Code: 1408-081; 1917-081; 1923-081; 1924-081

System Operation Description:

Use this procedure under the following situation:

Use this procedure to troubleshoot the system only when there is an active diagnostic code or when a diagnostic code can easily be activated. This procedure covers open circuit diagnostic codes and short circuit diagnostic codes that are associated with the following sensors:

- Boost pressure sensor
- Oil pressure sensor (optional)
- Atmospheric pressure sensor (specific ratings only)
- Injection actuation pressure sensor

Use this procedure for the following diagnostic codes:

- 100-03 Oil Pressure Sensor Open Circuit (27)
- 100-04 Oil Pressure Sensor Short Circuit (27)
- 102-00 Boost Pressure Reading Stuck High (25)

- 102-03 Boost Pressure Sensor Open Circuit (25)
- 102-04 Boost Pressure Sensor Short Circuit (25)
- 164-03 Injection Actuation Pressure Sensor Open Circuit (15)
- 164-04 Injection Actuation Pressure Sensor Short Circuit (15)
- 108-03 Atmospheric Pressure Sensor Open Circuit (26)
- 108-04 Atmospheric Pressure Sensor Short Circuit (26)

The following background information is related to this procedure:

The troubleshooting procedures for the diagnostic codes of each pressure sensor are identical. The pressure sensors are sensors that have three terminals. The pressure sensors are active sensors. Active sensors require supply voltage from the ECM. ECM connector J2/P2 terminal 2 supplies + 5 volts to terminal "A" of each sensor. ECM connector J2/P2 terminal 3 is the common connection for the pressure sensors. The sensor common connection is shared between all of the pressure sensors. The common line is connected to each sensor connector terminal "B". The signal voltage from terminal "C" of each sensor is supplied to the appropriate terminal at ECM connector J2/P2.

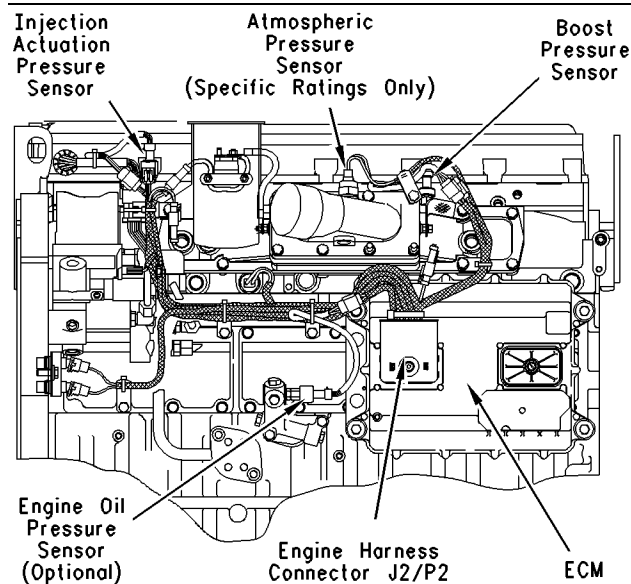

Illustration 82

g00767035

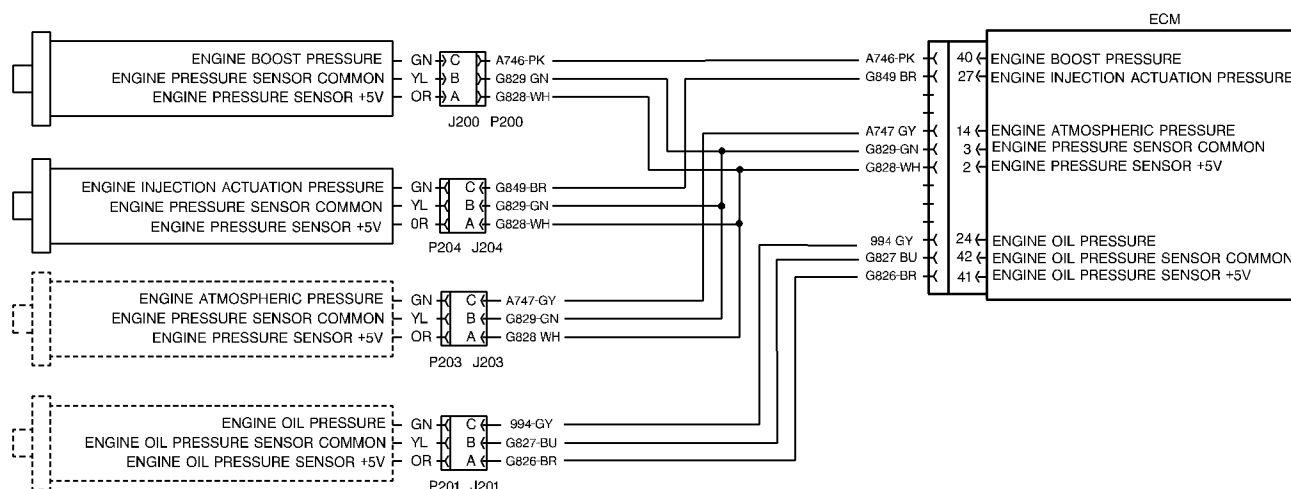

Illustration 83

g00767119

Test Step 1. Check for Active +5 V Sensor Supply Diagnostic Codes.

- A. Connect ET to the cab data link connector.
- B. Turn the ignition key switch to the ON position. Wait at least 15 seconds for activation of the diagnostic codes.
- C. Verify if any of the following diagnostic codes are active:
 - 232-03 5 Volt Supply Above Normal (21)
 - 232-04 5 Volt Supply Below Normal (21)

Expected Result:

One or more of the preceding diagnostic codes are active.

Results:

- Yes

Repair: Perform the following diagnostic procedure: Troubleshooting, "5 Volt Engine Pressure Sensor Supply Circuit - Test".

STOP.

- No – Proceed to Test Step 2.

Test Step 2. Verify All Active Diagnostic Codes.

- A. Turn the ignition key switch to the ON position. Wait at least 15 seconds for activation of the diagnostic codes.

- B. Verify if any of the following diagnostic codes are active:

- 100-03 Oil Pressure Sensor Open Circuit (27)
- 100-04 Oil Pressure Sensor Short Circuit (27)
- 102-00 Boost Pressure Reading Stuck High (25)
- 102-03 Boost Pressure Sensor Open Circuit (25)
- 102-04 Boost Pressure Sensor Short Circuit (25)
- 108-03 Atmospheric Pr Sensor Open Circuit (26)
- 108-04 Atmospheric Pr Sensor Short Circuit (26)
- 164-03 Injection Actuation Pressure Sensor Open Circuit (15)
- 164-04 Injection Actuation Pressure Sensor Short Circuit (15)

Note: The following diagnostic codes should not be active:

- 232-03 5 Volt Supply Above Normal (21)
- 232-04 5 Volt Supply Below Normal (21)

Expected Result:

One or more of the preceding diagnostic codes are active.

Results:

- Yes – Proceed to Test Step 4.
- No

Repair: If the preceding codes are logged but not active and the engine is not running properly, refer to Troubleshooting, “Troubleshooting without a Diagnostic Code”. If the engine is running properly at this time, an intermittent condition may be causing the logged codes. Refer to Troubleshooting, “Electrical Connectors - Inspect” for additional information on intermittent connections. If the problem is not evident and there were logged open circuit faults or short circuit faults, perform the following repair:

- 1.** Replace the pin terminals with **9X-3401** Connector Pin terminals.

Replace the socket terminals with **9X-3402** Connector Socket terminals.

- 2.** Do not replace the Sensor or the ECM.

Note: If the sensor has an integral connector the pin terminals cannot be removed. Only replace the socket terminal in the wiring harness connector.

STOP.

Test Step 3. Inspect Electrical Connectors and Wiring.

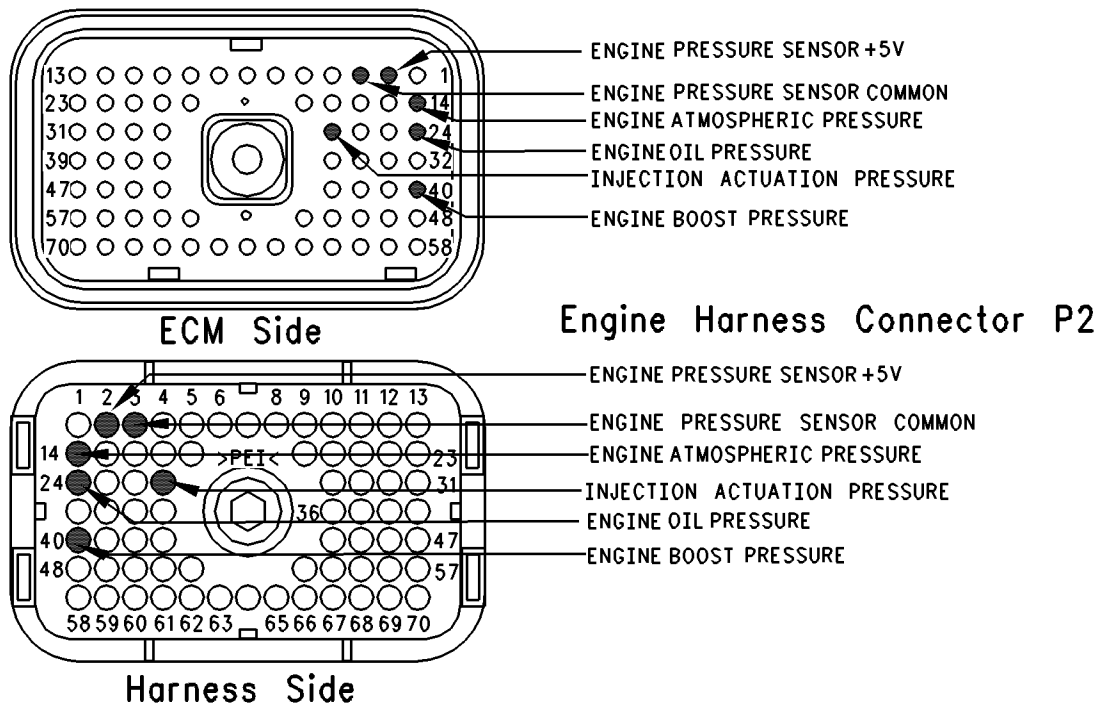

Illustration 84

g00741955

Terminal locations for ECM

- A.** Thoroughly inspect ECM engine harness connector J2/P2, boost pressure sensor J200/P200, engine oil pressure sensor J201/P201, injection actuation pressure sensor J204/P204, and atmospheric pressure sensor J203/P203. Refer to Troubleshooting, “Electrical Connectors - Inspect” for details.
- B.** Perform a 45 N (10 lb) pull test on each of the wires in the ECM Connector and the sensor connectors that are associated with the active diagnostic code.

Refer to Illustration 84.
- C.** Check the ECM connector (allen head screw) for the proper torque of 6.0 N·m (55 lb in).
- D.** Check the harness and wiring for abrasion and pinch points from the sensors back to the ECM.

Expected Result:

All connectors, pins and sockets should be completely coupled and/or inserted and the harness and wiring should be free of corrosion, abrasion or pinch points.

Results:

- OK – Proceed to Test Step 4.
- Not OK

Repair: Repair the connectors or wiring and/or replace the connectors or wiring. Ensure that all of the seals are properly in place and ensure that the connectors are completely coupled.

Verify that the repair eliminates the problem.

Clear all Logged diagnostic codes.

STOP.

Test Step 4. Verify that the Diagnostic Code is Still Active.

- A.** Turn the ignition key switch to the ON position. Wait at least 15 seconds for activation of the diagnostic codes.
- B.** Monitor the “ Active Diagnostic Code” screen of ET. Check and record active diagnostic codes.
- C.** Determine if the problem is related to an open circuit diagnostic code or a short circuit diagnostic code.

Expected Result:

Either a short circuit diagnostic code is active or an open circuit diagnostic code is active.

Results:

- **SHORT Circuit** – A short circuit diagnostic code is active at this time. Proceed to Test Step 5.
- **OPEN Circuit** – An open circuit diagnostic code is active at this time. Proceed to Test Step 6.

Test Step 5. Disconnect the Sensor in order to Create an Open Circuit.

- Turn the ignition key switch to the OFF position.
- Disconnect the sensor connector of the sensor with the short circuit diagnostic code.
- Turn the ignition key switch to the ON position. Wait at least 15 seconds for activation of the diagnostic codes.
- Access the “Active Diagnostic Code” screen on ET. Check for an active open circuit diagnostic code.

Expected Result:

An open circuit diagnostic code for the disconnected sensor is now active.

Results:

- **OK** – A short circuit diagnostic code was active before disconnecting the sensor. An open circuit diagnostic code became active after disconnecting the sensor. Proceed to Test Step 7.
- **Not OK** – There is a short circuit between the sensor harness connector and the ECM. Leave the sensor disconnected. Proceed to Test Step 9.

Test Step 6. Measure the Sensor Supply Voltage.

- Turn the ignition key switch to the OFF position.
- Disconnect the sensor from the engine harness.
- Connect a 3-Terminal breakout T to the engine harness only. Do Not connect the sensor to the breakout T.
- Turn the ignition key switch to the ON position.
- Set a multimeter to the “VDC” setting. Measure the voltage from the terminal “A” (pressure sensor supply) to terminal “B” (sensor common).

Expected Result:

The DC voltage from terminal “A” to terminal “B” measures 4.5 to 5.5 VDC.

Results:

- **OK** – The sensor supply voltage is correct. Remove the Breakout T. Proceed to Test Step 8.
- **Not OK** – The sensor supply voltage is out of range. Continue testing the sensor supply circuit.

Repair: Proceed to the following repair: Troubleshooting, “5 Volt Engine Pressure Sensor Supply Circuit - Test”

STOP.

Test Step 7. Determine if the Short Circuit is in the Connector or in the Sensor.

- Thoroughly inspect the connector for moisture.
- Inspect the seals and reconnect the sensor.
- If the short circuit diagnostic code reappears, the sensor or the pigtail harness connector is the problem.
 - Temporarily connect a new sensor to the harness, but do not install the new sensor in the engine.
- Check for a short circuit diagnostic code while the new sensor is connected to the harness.

Expected Result:

The short circuit diagnostic code is not present when a new sensor is connected.

Results:

- **OK** – Verify that the repair eliminates the problem. Clear the logged diagnostic codes. STOP.
- **Not OK** – Repair the engine harness connector. STOP.

Test Step 8. Create a Short Circuit Between the Signal and the Common

Terminals at the Engine Harness Connector.

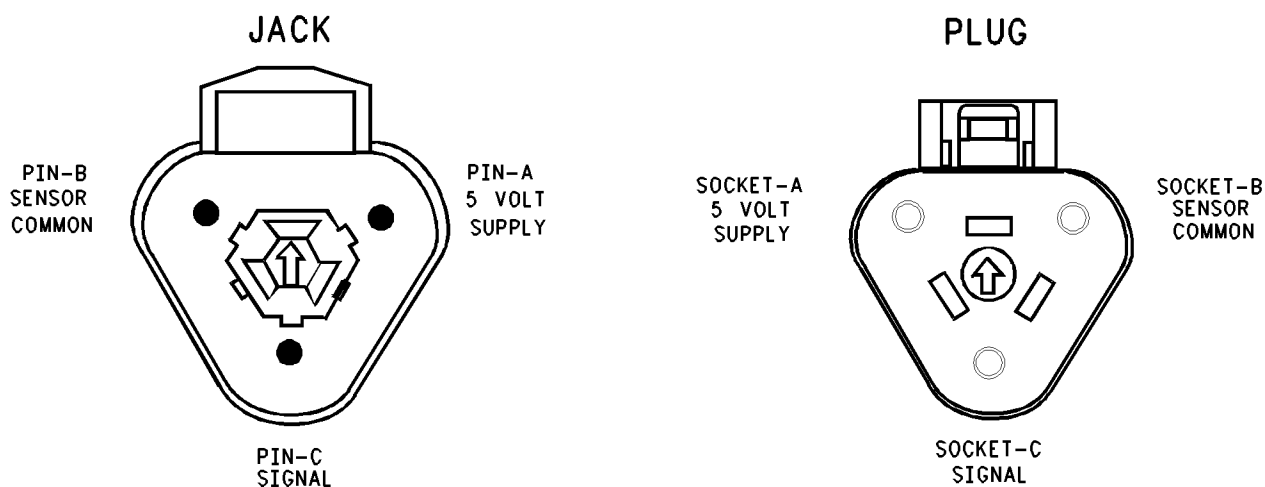

Illustration 85

g00664397

Terminals for the pressure sensor connector

- A.** Turn the ignition key switch to the ON position.
 - B.** Fabricate a jumper wire 150 mm (6 inch) long. Crimp a Deutsch terminal to both ends of the wire.
 - C.** Monitor the “Active Diagnostic Code” screen before installing the jumper wire and after installing the jumper wire.
 - D.** Install the jumper on the engine harness connector. Install one end of the jumper at the sensor signal (terminal “C”). Install the other end of the jumper at the common connection for the pressure sensor (terminal “B”). Wait at least 15 seconds for activation of the short circuit diagnostic code.
- 3.** Ensure that the diagnostic code is no longer active.
 - 4.** Verify that the repair eliminates the problem.
- STOP.**
- **Not OK** – The open circuit diagnostic code remains active when the jumper is installed. The most probable location for the open is in the sensor common or the sensor signal wire in the engine harness between the ECM and the sensor. Remove the jumper. Proceed to Test Step 9.

Refer to Illustration 85.

Expected Result:

A short circuit diagnostic code is active when the jumper is installed. An open circuit diagnostic code is active when the jumper is removed.

Results:

- **OK** – The engine harness and the ECM are OK.

Repair: Perform the following repair:

- 1.** Temporarily connect the suspect sensor.
- 2.** If the diagnostic code remains active, replace the sensor.

Test Step 9. Check the Operation of the ECM by Creating Open and Short Circuits at the ECM Connector.

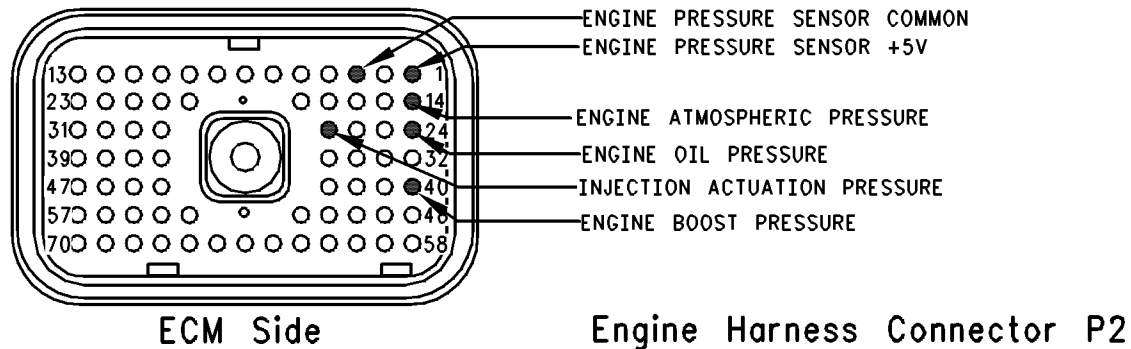

Illustration 86

g00741957

Engine harness connector P2

- A.** Turn the ignition key switch to the OFF position.
- B.** Disconnect ECM engine harness connector J2/P2. Thoroughly inspect both halves of the connector J2/P2 for signs of corrosion or moisture.
- C.** Turn the ignition key switch to the ON position. Monitor the “Active Diagnostic Code” screen. Wait at least 15 seconds for activation of the code.
- D.** Turn the ignition key switch to the OFF position.
- E.** Fabricate a jumper wire 150 mm (6 inch) long. Crimp a Deutsch Socket to both ends of the wire.
- F.** Install the jumper wire on the ECM connector J2. Insert the jumper wire between the terminal for the suspect sensor signal and the common connection for the engine’s pressure sensor (terminal 3).

An open circuit diagnostic code should be active for the suspect sensor.

Note: When the engine harness is disconnected, all of the open circuit diagnostic codes for the pressure sensors will be active. This is normal. Disregard the diagnostic codes for the other pressure sensors. Direct your attention to the diagnostic codes for the suspect sensor only.

A short circuit diagnostic code should be active when the jumper wire is installed.

Note: If access to ECM connector J2 is limited, it may be helpful to connect a breakout T to ECM connector J2 so the jumper wire can be inserted into the breakout T. Ensure that the jumper wire is inserted into the breakout T and that the full wiring harness is attached.

Refer to Illustration 86 for the engine harness connector P2.

Expected Result:

Open circuit diagnostic codes and short circuit diagnostic codes were active.

Results:

- **OK** – The ECM is operating properly. Proceed to Test Step 10.
- **Not OK** – One of the following conditions exists: The open circuit diagnostic code is not active when the harness is disconnected. The short circuit diagnostic code is not active when the jumper wire is installed.

Repair: Perform the following repair:

1. Temporarily connect a test ECM.
2. Remove all jumpers and replace all connectors.
3. Recheck the system for active diagnostic codes.
4. Repeat the Test Step.
5. If the problem is resolved with the test ECM, reconnect the suspect ECM.

6. If the problem returns with the suspect ECM, replace the ECM.

7. Verify that the repair eliminates the problem.

STOP.

Test Step 10. Bypass the Harness Wiring Between the ECM and the Sensor Connector.

A. Turn the ignition key switch to the OFF position.

B. Disconnect ECM engine harness connector J2/P2, and the sensor connector.

C. Remove the sensor signal wire from ECM connector P2 on the engine harness.

D. Remove the signal wire (terminal "C") from the sensor connector on the engine harness .

E. Fabricate a jumper wire that is long enough to reach from the ECM to the sensor connector or use an engine sensor harness bypass with 3 terminals.

Note: If an engine sensor harness bypass is being made, crimp a Deutsch socket on one end in order to connect to the ECM. Crimp either a Deutsch pin or a Deutsch socket on the other end, as required.

F. Insert the engine sensor harness bypass into the ECM connector P2 on the engine harness. Insert the other end of the engine sensor harness bypass into the sensor connector of the engine harness .

G. Reconnect ECM engine harness connector J2/P2 and the sensor connector.

H. Turn the ignition key switch to the ON position.

I. Monitor the "Active Diagnostic Code" screen for either the open circuit diagnostic code for the sensor or the short circuit diagnostic code for the sensor.

Expected Result:

The diagnostic code disappears when the jumper or the bypass is installed.

Results:

- OK – There is a problem in the wiring harness.

Repair: Perform the following repair:

1. Repair the faulty wiring harness or replace the faulty wiring harness.

2. Clear all diagnostic codes.

3. Verify that the repair eliminates the problem.

STOP.

- Not OK – Restart this procedure and carefully perform each step. STOP.

i01606388

Engine Running Output Circuit - Test

SMCS Code: 1900-081

System Operation Description:

Use this procedure under the following situation:

Use this procedure in order to determine if the circuit for the Engine Running Output is operating properly.

The following background information is related to this procedure:

Personality Modules that have a Software Date Code dated earlier than OCT01.

The Engine Running Output is located on ECM J1/P1:13 (Output 4).

The engine running output comes on when the engine is running. The engine running output turns off when the engine rpm equals 0. This can be used to prevent the engagement of the starter motor while the engine is running. The ECM can be connected to a relay that disables the starter. The relay is normally closed so cranking can be achieved immediately at powerup. During cranking, the ECM energizes the engine running output once engine rpm reaches 50 rpm below low idle. The output is de-energized if the engine speed falls below the programmed low idle by 100 rpm. The low idle rpm is programmable. The range for low idle is between 700 rpm and 800 rpm.

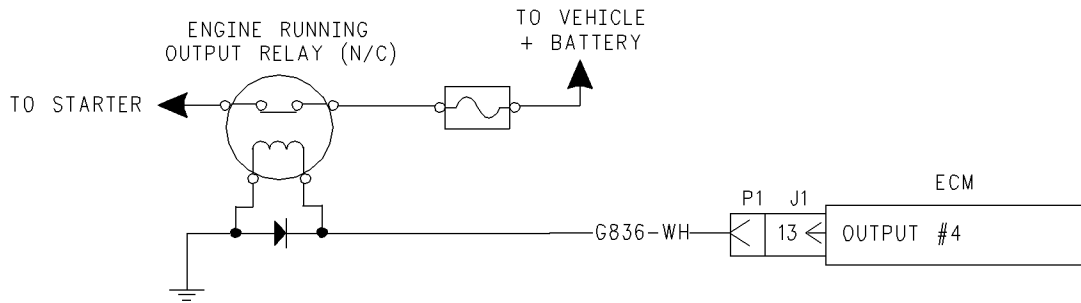

Illustration 87
 Engine Running Output Circuit

g00832285

Personality Modules that have a Software Date Code dated OCT01.

GMT-560 applications have a programmable parameter "Engine Running Output" that can be programmed to "P1/J1:31". If this parameter is programmed, the engine running output is located on ECM J1/P1:31 (Output 9). This feature allows the ECM to control a relay in order to prevent the starter motor from being engaged after the engine has started.

When the ignition key switch is turned to the ON position, Output 9 is low. The relay is off and the switch is closed. Current flows to the starter solenoid and this allows the starter to engage. When the engine speed reaches 600 rpm the output will go high. This energizes the relay and the switch opens. When the switch is open there is no current flow to the starter solenoid.

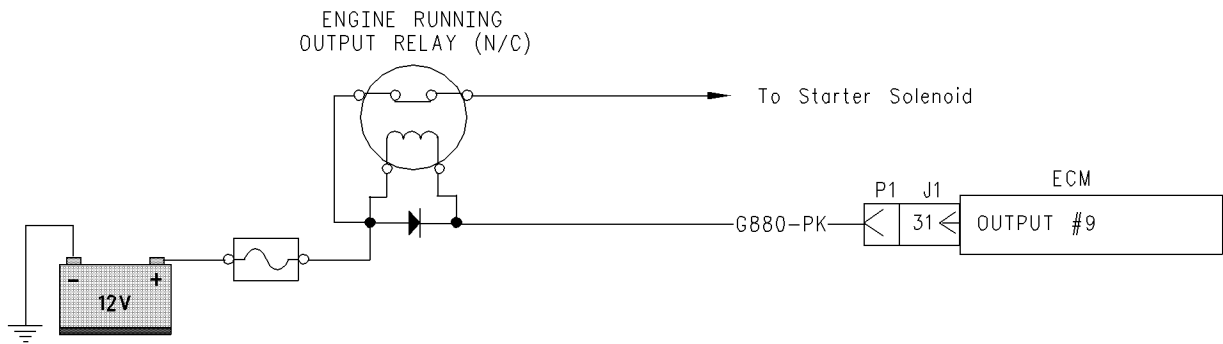

Illustration 88
 Engine Running Output Circuit for GMT-560

g00832209

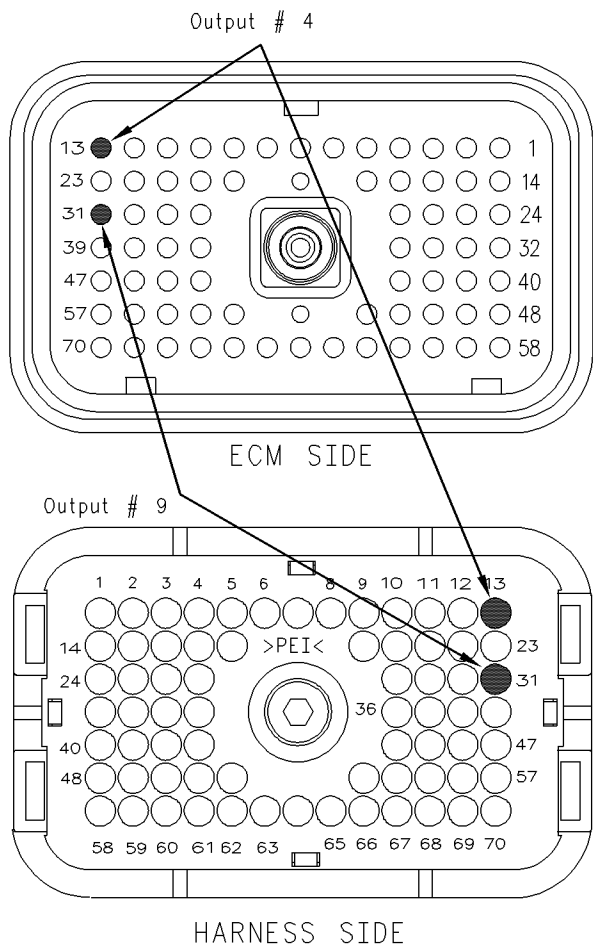

Illustration 89

g00832305

Location for the ECM terminal

Test Step 1. Inspect Electrical Connectors and Wiring.

- A.** Thoroughly inspect ECM vehicle harness connector J1/P1, and the firewall bulkhead connector.

Refer to Troubleshooting, “Electrical Connectors - Inspect” for details.
- B.** Perform a 45 N (10 lb) pull test on terminal 13 in the ECM connector.
- C.** Check the ECM connector (allen head screw) for the proper torque of 6.0 N·m (55 lb in).
- D.** Check the harness and wiring for abrasion and for pinch points from the sensor to the ECM.

Expected Result:

All connectors, pins and sockets should be completely coupled and/or inserted and the harness and wiring should be free of corrosion, abrasion or pinch points.

Results:

- OK – Proceed to Test Step 2.
- Not OK

Repair: Perform the following repair:

Repair the connectors or wiring and/or replace the connectors or wiring. Ensure that all of the seals are properly in place and ensure that the connectors are completely coupled.

Verify that the repair eliminates the problem.

STOP.

Test Step 2. Use ET to Check the Relay.

- A.** Turn the ignition key switch to the ON position.
- B.** Access the special test “Engine Running Output” on ET. The “Engine Running Output” test will enable the engine running output when the test is active.
- C.** Begin the “Engine Running Output” test and listen for the relay to “click”. You may need to be near the engine in order to hear the “click”.

Expected Result:

The relay activates when the special test is enabled.

Results:

- Yes – The ECM and vehicle components are operating correctly. **STOP.**
- No – Proceed to Test Step 3.

Test Step 3. Use ET to Check the ECM.

- A.** Connect ET to the cab data link connector.
- B.** Turn the ignition key switch to the OFF position.
- C.** Disconnect the ECM vehicle harness connector J1/P1.
- D.** Connect a breakout T between ECM connectors J1 and P1.
- E.** Connect a voltage test lamp to terminal 13 (Output 4) and terminal 65 (-battery) of the breakout T.

Note: If the vehicle is a GM-560 application, connect the voltage test lamp to terminal 31 (Output 9) and terminal 65 (-battery) of the breakout T.

- F.** Turn the ignition key switch to the ON position.

- G. Access the special test “Engine Running Output” on ET.
- H. Cycle the special test “Engine Running Output” to “Active” and to “Not Active” and watch the voltage test lamp.
- I. Stop the special test.

Note: A multimeter can not be used in place of the voltage test lamp when the ECM outputs are being tested.

Expected Result:

The voltage test lamp turns ON when the test is active. The voltage test lamp turns OFF when the test is not active.

Results:

- **Yes** – The ECM is OK. The problem is in the vehicle wiring. Inspect the vehicle wiring and then repair the vehicle wiring. Otherwise, send the vehicle to the OEM dealer for repair. Verify that the original condition is resolved. **STOP.**
- **No** – Temporarily connect a test ECM. Use the “Engine Running Output Special Test” on ET to check the ECM. If the problem is resolved with the test ECM, install the suspect ECM. If the problem returns with the suspect ECM, replace the ECM. Verify that the repair eliminates the problem. **STOP.**

i01857873

Engine Speed/Timing Sensor Circuit - Test

SMCS Code: 1912-081

System Operation Description:

Use this procedure under the following situation:

Use this procedure to troubleshoot the system only under the following conditions:

- There is an active diagnostic code or an easily repeated diagnostic code that is associated with the engine speed/timing circuit.
- You have been referred to this test from Troubleshooting, “Troubleshooting without a Diagnostic Code”.

The following background information is related to this procedure:

The engine uses two engine speed/timing sensors. Both of the engine speed/timing sensors detect the reference for engine speed and timing from a unique pattern on the camshaft gear. The ECM counts the time between pulses that is created by the sensor as the gear rotates in order to determine rpm. The ECM remembers the pattern of the pulses. The ECM uses the pattern of the pulses in order to determine the position of the crankshaft.

When the timing has been established, the ECM triggers each injector in the correct firing order at the correct time.

The actual timing and duration of each injection is based on engine rpm and load. If the engine is running and the signal from one of the camshaft position sensors is lost, no noticeable change in engine performance will be noticed.

The engine will start and the engine will run when only one sensor signal is present from either of the sensors. The loss of the signal from both of the sensors during engine operation will result in the termination of injection and the shutting down the engine by the ECM. The loss of the signal from both of the sensors during start-up will prevent the engine from starting.

Both sensors are magnetic sensors. The two sensors are not interchangeable. Do not switch the positions of the sensors. The two sensors must be replaced as a pair. If the sensors are replaced, a timing calibration is not necessary for the engine. **Timing calibration is only necessary after replacing an ECM that will not communicate.**

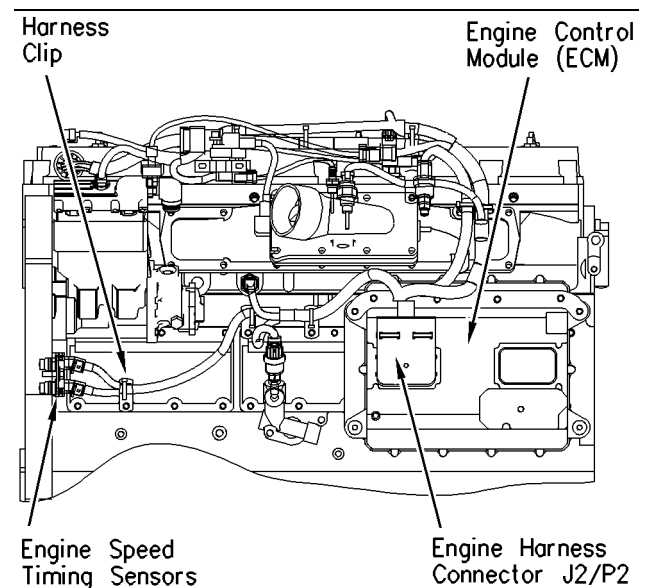

Illustration 90
Left side engine view (typical view)

g00864785

If a replacement of the ECM is required, the ECM parameters and the timing calibration can be transferred from the suspect ECM to the replacement ECM. Timing calibration will not be necessary. This feature requires an electronic service tool and this feature is only possible if the existing ECM can communicate with the electronic service tool. Use the procedure "Copy Configuration - ECM Replacement" on the electronic service tool. Refer to Troubleshooting, "Programming Parameters" for more information.

When the sensors are being installed, complete all of the following tasks:

- Lubricate the O-ring with oil.
- Ensure that the sensor has a face seal inside the connector body. If a seal is damaged or missing, replace the seal.
- Ensure that the sensor is fully seated into the engine before tightening the bracket bolt.
- Ensure that the connector is latched on both sides.
- Ensure that the harness is properly secured, and ensure that the harness is attached to the harness clip.

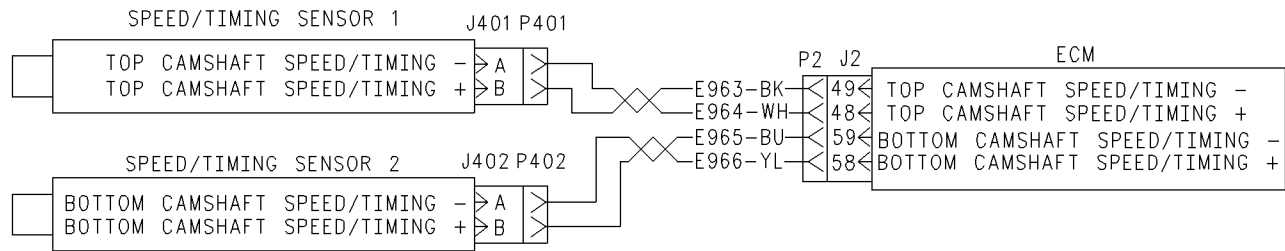

Illustration 91

g00866705

Circuit schematic for the speed/timing sensors

Test Step 1. Connect the Electronic Service Tool and Note all Active Diagnostic Codes and Logged Diagnostic Codes

- A. Connect the electronic service tool to the cab data link connector.
- B. Turn the ignition key switch to the ON position.
- C. Check for one of the following logged diagnostic codes or active diagnostic codes:

- 64-11 No Pattern on Speed Sensor #2 (34)
- 190-02 Loss of Engine RPM Signal (34)
- 190-11 No Pattern on Speed Sensor #1 (34)

- 64-02 Loss of Engine RPM Signal #2 (34)

Note: If the diagnostic code is logged but not active, run the engine until the engine is at normal operating temperature. The problem may only occur when the engine is at the normal operating temperature. If the engine will not start, monitor the engine rpm from the electronic service tool while the engine is being cranked. The electronic service tool may need to be powered from another battery while the engine is being cranked. This is done in order to ensure that the electronic service tool does not reset.

Expected Result:

One or more of the diagnostic codes that are listed above are logged or active.

Note: If you have been referred here from Troubleshooting, “Troubleshooting without a Diagnostic Code” for the following reason, select “No Engine rpm”:

- The engine rpm was not indicated on the electronic service tool.

Results:

- **OK** – There is an active diagnostic code or a logged diagnostic code. Proceed to Test Step 3.
- **Not OK** – If none of the codes that are listed are active diagnostic codes or logged diagnostic codes and the engine is not running properly, refer to the appropriate symptoms in the service manual. **STOP.**
- **No Engine rpm** – Engine rpm is not indicated on the electronic service tool. Proceed to Test Step 2.

Test Step 2. Check the Installation of the Sensors and the Bracket

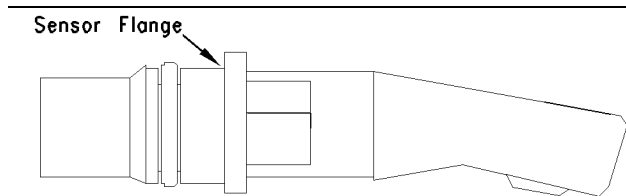

Illustration 92

g00767308

Flange of the sensor and mounting bracket

- A.** The flange of the sensor should be flush against the engine in order to ensure proper operation.
- B.** Inspect the bracket in order to ensure that the installation allows the flange of the sensor to be flush against the engine.

Verify that the bracket is not bent.

Note: The bracket cannot be replaced separately.

- C.** Ensure that one O-ring has been installed on the sensor, and ensure that the O-ring is free of damage.

Note: If the flange of the sensor is bent or if an obstruction is preventing the sensor from reading a good pattern, the engine will not start.

Results:

- **OK** – The sensors and the bracket are properly installed. Proceed to Test Step 3.
- **Not OK**

Repair: Perform the following procedure in order to properly install the sensors and the bracket:

- 1.** Loosen the bolt that holds the sensor mounting bracket to the engine.
- 2.** Seat the sensor and tighten the bolt.

If the sensor will not seat, repair the sensor or replace the sensor, as required.

Note: The sensor must not be removed from the bracket.

- 3.** Ensure that the sensor is properly oriented and that the harness is secured in the proper location.
- 4.** Verify that the repair eliminates the problem.

STOP.

Test Step 3. Measure the Sensor Resistance Through the Engine Harness

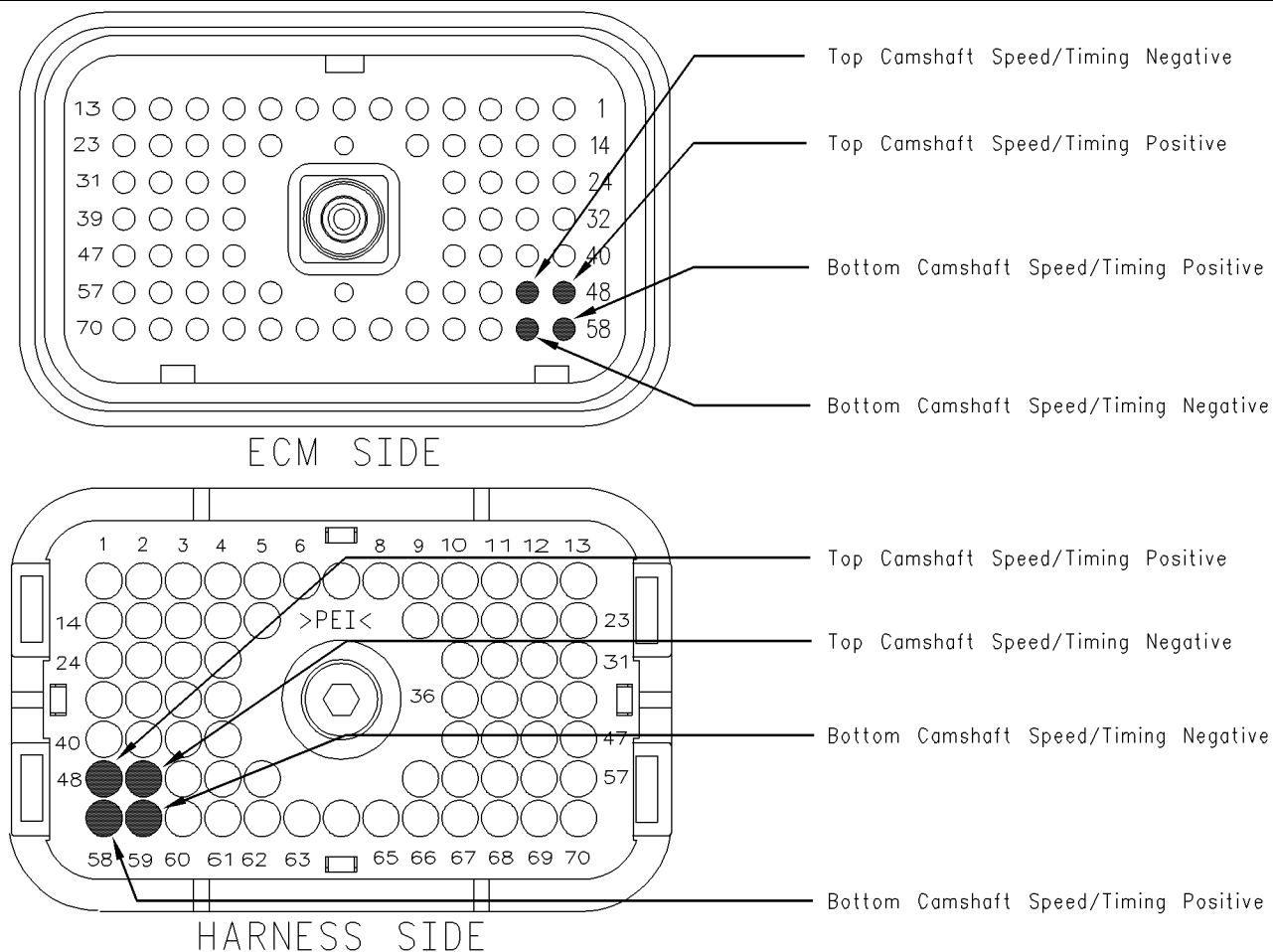

Illustration 93

g00864786

Terminal locations for ECM connector P2

- A.** Turn the ignition key switch to the OFF position.
- B.** Thoroughly inspect ECM vehicle harness connector J2/P2. Refer to Troubleshooting, "Electrical Connectors - Inspect" for details.
- C.** Perform a 45 N (10 lb) pull test on the following wires in the ECM engine harness connector P2 that are associated with the engine speed/timing sensors:
 - P2:48
 - P2:49
 - P2:58
 - P2:59
- D.** Ensure that the latch tab on the connector is properly latched and ensure that the latch tab is fully latched.
- E.** Check the ECM connector (allen head screw) for the proper torque of 6.0 N·m (55 lb in).
- F.** Repair the harness or repair the connector if a problem is found.
- G.** Ensure that the wiring harness is correctly routed and secured at the proper locations.
- H.** Ensure that the harness wiring is not pulled too tightly. When the harness wiring is pulled too tightly, vibrations or movement can cause intermittent connections.
- I.** Inspect the harness wiring for nicks and abrasions.
- J.** If the harness and the connector are OK, disconnect ECM connector J2/P2.

Refer to Illustration 93.

K. Use the following procedure to measure the sensor resistance (Ohms) for the top camshaft position sensor:

Refer to Illustration 93.

- a. Use a multimeter to measure the resistance from P2:48 (Top Camshaft Speed/Timing Sensor Positive) to P2:49 (Top Camshaft Speed/Timing Sensor Negative).
- b. Check for an intermittent open circuit or short circuit by moving the harness while the measurement for resistance is being taken. Pull the wires that are directly behind the sensors or shake the wires that are directly behind the sensors.

Resistance 75 to 230 Ohms

L. Use the following procedure to measure the sensor resistance (Ohms) for the bottom camshaft position sensor:

Refer to Illustration 93.

- a. Use a multimeter to measure the sensor resistance (Ohms) from P2: 58 (Bottom Camshaft Speed/Timing Positive) to P2:59 (Bottom Camshaft Speed/Timing Negative).
- b. Check for an intermittent open circuit or short circuit by moving the harness while the measurement for resistance is being taken. Pull the wires that are directly behind the sensors or shake the wires that are directly behind the sensors.

Resistance 600 to 1800 Ohms

Expected Result:

The readings agree with the values that are listed above.

Results:

- **OK** – Neither a short circuit nor an open circuit is indicated. Proceed to Test Step 5.
- **Not OK** – The sensor resistance is not within the acceptable range when the sensor resistance is measured through the engine harness. Proceed to Test Step 4.

Test Step 4. Measure the Resistance of the Sensor at the Sensor

A. Turn the ignition key switch to the OFF position.

B. Check the harness and the wiring for abrasion and pinch points from the sensor back to the ECM.

C. Disconnect the suspect sensor from the engine harness.

D. Thoroughly inspect ECM engine harness connectors for the sensors J401/P401 or J402/P402. Refer to Troubleshooting, “Electrical Connectors - Inspect” for details.

E. Use the following procedure to measure the sensor resistance (Ohms) for the camshaft position sensor at the sensor connector between terminal A and Terminal B:

- a. Use a multimeter to measure the sensor resistance (Ohms) from J401:B (E964-WH) to J401:A (E963-BK).

Terminal B of the sensor connector is Top Camshaft Speed/Timing Positive.

Terminal A of the sensor connector is Top Camshaft Speed/Timing Negative.

Resistance 75 to 230 Ohms

F. Use the following procedure to measure the sensor resistance (Ohms) for the bottom camshaft position sensor at the sensor connector between terminal A and terminal B:

- a. Use a multimeter to measure the sensor resistance (Ohms) from J402:B (E966-YL) to J402:A (E965-BU).

Terminal B of the sensor connector is Bottom Camshaft Speed/Timing Positive.

Terminal A of the sensor connector is Bottom Camshaft Speed/Timing Negative.

Resistance 600 to 1800 Ohms

Note: Timing calibration is not necessary following replacement of the speed/timing sensors. Refer to the information in the System Operation Section regarding the installation of sensors.

Expected Result:

The readings agree with the values that are listed above.

Results:

- **OK** – The sensor resistance is correct. Proceed to Test Step 5.

- **Not OK** – The sensor resistance is out of the range.

Repair: Perform the following procedure in order to check and install the new sensor:

1. Before installing the new sensor, measure the resistance of the new sensor.

Note: If the new sensor resistance is not in the correct range, inspect the wiring harness for damage.

If the new sensor resistance is in the correct range, install the new sensor in the engine, as follows:

- a. Loosen the bolt that holds the sensor mounting bracket to the engine.
- b. Ensure that one O-ring is installed and free of damage.
- c. Seat the sensor and tighten the bolt.

If the sensor will not seat, repair the sensor or replace the sensor, as required.

Note: The sensor must not be removed from the bracket.

- d. Ensure that the sensor is properly oriented and that the harness is secured in the proper location.

2. Verify that the repair eliminates the problem.

STOP.

Test Step 5. Install the Bypass Harness for the Engine Speed/Timing Sensors

- A. Turn the ignition key switch to the OFF position.
- B. Disconnect ECM connector J2/P2.
- C. Install the wiring harness to the ECM engine harness connector P2. Connect the wiring:
 - P2:48 to the white wire
 - P2:49 to the black wire
 - P2:58 to the yellow wire
 - P2:59 to the blue wire

Note: Twisted pair wiring is required. Ensure that the wires have at least one twist per inch.

- D. Reconnect the engine harness connector J2/P2.

- E. Start the engine in order to determine if the bypass harness repairs the problem.

Expected Result:

The problem is corrected with the installation of the bypass harness.

Results:

- **OK** – The bypass harness corrected the problem.

Repair: Permanently install a new section of harness.

STOP.

- **Not OK** – The bypass harness did not correct the problem.

Repair: Verify that the correct terminals have been installed in the correct location of the ECM engine harness connector P2. If the temporary harness was installed correctly, install the original wiring.

Proceed to Test Step 6.

Test Step 6. Check the ECM

- A. Turn the ignition key switch to the OFF position.
- B. Temporarily connect a test ECM.
- C. Start the engine. Run the engine in order to repeat the conditions when the problem occurs.
- D. If the problem is resolved with the test ECM, reconnect the suspect ECM.
- E. If the problem returns with the suspect ECM, replace the ECM.

Verify that the repair eliminates the problem.

Expected Result:

The problem remains with the suspect ECM.

Results:

- **OK** – The problem is resolved with the test ECM and the problem returns with the suspect ECM. Replace the ECM. Verify that the repair eliminates the problem. **STOP.**
- **Not OK** – The problem was not resolved with a test ECM.

Repair: Replace the sensor.

Verify that the repair eliminates the problem.

STOP.

i01857895

Engine Temperature Sensor Open or Short Circuit - Test

SMCS Code: 1906-081; 1917-081; 1922-081;
1928-081

System Operation Description:

Use this procedure under the following situation:

Use this procedure to troubleshoot the system only when there is an active diagnostic code or when a diagnostic code can easily be activated. This procedure covers open circuit diagnostic codes and short circuit diagnostic codes that are associated with the following sensors:

- coolant temperature sensor
- air inlet temperature sensor

Use this procedure for the following Diagnostic Codes:

- 105-03 Inlet Manifold Temp Sensor Open Circuit (38)
- 105-04 Inlet Manifold Temp Sensor Short Circuit (38)
- 110-03 Coolant Temp Sensor Open Circuit (27)
- 110-04 Coolant Temp Sensor Short Circuit (27)

The following background information is related to this procedure:

The troubleshooting procedures for the diagnostic codes of each temperature sensor are identical. The temperature sensors are passive sensors that have two terminals. The passive sensors do not require supply voltage from the ECM. ECM connector J2/P2 terminal 18 is the common connection for the engine temperature sensors. The sensor common connection is shared between all of the temperature sensors. The common line is connected to each sensor connector terminal 2. Terminal 1 is the sensor output. The signal from terminal 1 of each sensor is supplied to the appropriate terminal at ECM connector J2/P2.

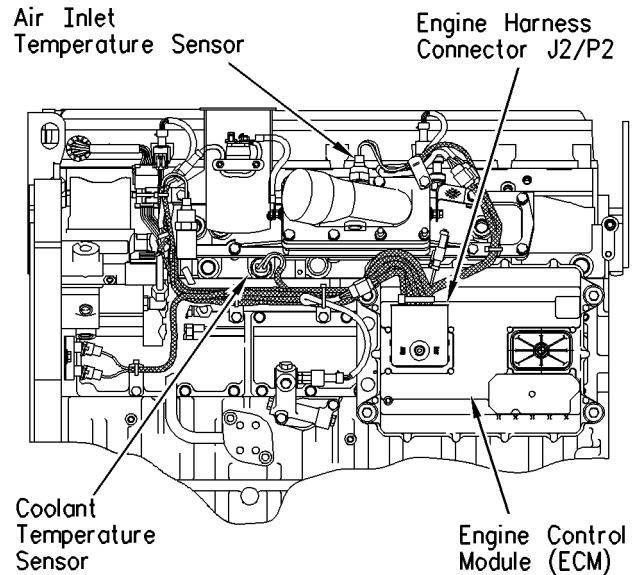

Illustration 94

g00767354

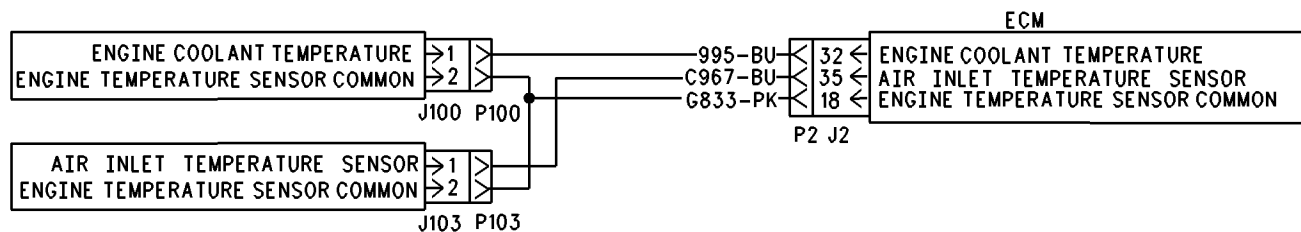

Illustration 95

g00724478

Schematic for engine temperature sensors

Test Step 1. Verify All Active Diagnostic Codes.

- A. Connect an electronic service tool to the cab data link connector.
- B. Turn the ignition key switch to the ON position. Wait at least 15 seconds for activation of the diagnostic codes.
- C. Verify if any of the following diagnostic codes are active:
 - 105-03 Inlet Manifold Air Temp Sensor Open Circuit (38)
 - 105-04 Inlet Manifold Air Temp Sensor Short Circuit (38)
 - 110-03 Coolant Temp Sensor Open Circuit (27)
 - 110-04 Coolant Temp Sensor Short Circuit (27)

Expected Result:

One or more of the preceding diagnostic codes are active.

Results:

- Yes – Proceed to Test Step 2.
- No

Repair: If the preceding codes are logged but not active and the engine is not running properly, refer to Troubleshooting, "Troubleshooting without a Diagnostic Code". If the engine is running properly at this time, an intermittent condition may be causing the logged codes. Refer to Troubleshooting, "Electrical Connectors - Inspect".

STOP.

Test Step 2. Inspect Electrical Connectors and Wiring.

ENGINE HARNESS CONNECTOR P2

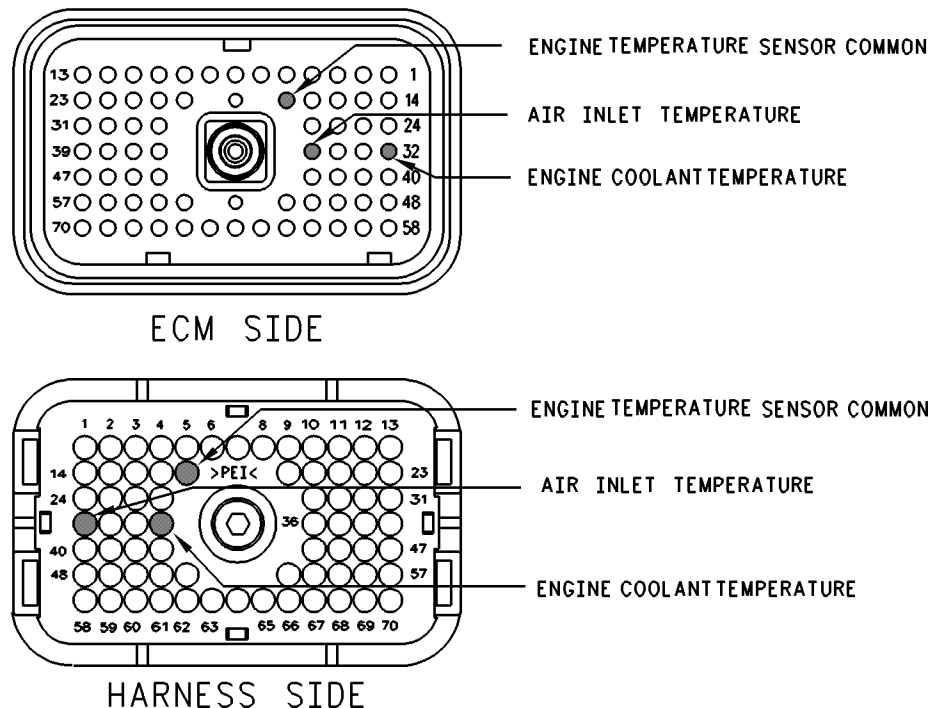

Illustration 96

g00724517

- A.** Thoroughly inspect ECM engine harness connector J2/P2 and the suspect sensor connector. Refer to Troubleshooting, “Electrical Connectors - Inspect” for details.
- B.** Perform a 45 N (10 lb) pull test on each of the wires in the sensor connector and the ECM connector that are associated with the active diagnostic code.

Refer to Illustration 96.
- C.** Verify that the latch tab of the connector is properly latched and that the latch tab of the connector has returned to the Fully Latching position.
- D.** Check the ECM connector (allen head screw) for the proper torque of 6.0 N·m (55 lb in).
- E.** Check the harness and wiring for abrasion and pinch points from the sensor to the ECM.

Expected Result:

All connectors, pins and sockets should be completely coupled and/or inserted and the harness and wiring should be free of corrosion, abrasion or pinch points.

Results:

- OK – Proceed to Test Step 3.
- Not OK

Repair: Repair the connectors or wiring and/or replace the connectors or wiring. Ensure that all of the seals are properly in place and ensure that the connectors are completely coupled.

Verify that the repair eliminates the problem.

STOP.

Test Step 3. Verify that the Diagnostic Code is Still Active.

- A.** Turn the ignition key switch to the ON position. Wait at least 15 seconds for activation of the diagnostic codes.
- B.** Access the “Active Diagnostic Code” screen of the electronic service tool. Check for active diagnostic codes.
- C.** Determine if the problem is related to an open circuit diagnostic code or a short circuit diagnostic code.

Expected Result:

A short circuit diagnostic code or an open circuit diagnostic code is active.

Results:

- **Short Circuit** – A short circuit diagnostic code is active at this time. Proceed to Test Step 4.
- **Open Circuit** – An open circuit diagnostic code is active at this time. Proceed to Test Step 5.

Test Step 4. Disconnect the Sensor in order to Create an Open Circuit.

- A.** Turn the ignition key switch to the OFF position.
- B.** Disconnect the sensor connector of the sensor with the short circuit diagnostic code.
- C.** Turn the ignition key switch to the ON position. Wait at least 15 seconds for activation of the diagnostic codes.
- D.** Access the “Active Diagnostic Code” screen on the electronic service tool. Check for an active open circuit diagnostic code.

Expected Result:

An open circuit diagnostic code for the disconnected sensor is now active.

Results:

- **OK** – A short circuit diagnostic code was active before disconnecting the sensor. An open circuit diagnostic code became active after disconnecting the sensor. Proceed to test step 6.
- **Not OK** – There is a short circuit between the sensor harness connector and the ECM. Leave the sensor disconnected. Proceed to Test Step 7.

Test Step 5. Create a Short Circuit Between the Signal and the Common Terminals at the Sensor Connector.

- A.** Turn the ignition key switch to the ON position.
- B.** Fabricate a jumper wire 150 mm (6 inch) long. Crimp a Deutsch terminal to both ends of the wire.
- C.** Monitor the “Active Diagnostic Code” screen before installing the jumper wire and after installing the jumper wire.

- D.** Install the jumper on the engine harness connector. Install one end of the jumper at the sensor signal (terminal 1). Install the other end of the jumper at the common connection for the engine temperature sensor (terminal 2). Wait at least 15 seconds for activation of the short circuit diagnostic code.

Expected Result:

A short circuit diagnostic code is active when the jumper is installed. An open circuit diagnostic code is active when the jumper is removed.

Results:

- **OK** – The engine harness and the ECM are OK.

Repair: Perform the following repair:

- 1.** Temporarily connect the suspect sensor.
- 2.** If the diagnostic code remains active, replace the sensor.
- 3.** Verify that the repair eliminates the problem.
- 4.** Clear all Logged diagnostic codes.

STOP.

- **Not OK** – The open circuit diagnostic code remains active with the jumper in place. The most probable location for the open is in the sensor common or the sensor signal wire in the engine harness between the ECM and the sensor. Remove the jumper. Proceed to Test Step 7.

Test Step 6. Determine if the Short Circuit is in the Connector or in the Sensor.

- A.** Thoroughly inspect the connector for moisture.
- B.** Inspect the seals and reconnect the sensor.
- C.** If the short circuit diagnostic code reappears, the sensor is the problem.
 - a.** Temporarily connect a new sensor to the harness, but do not install the new sensor in the engine.
- D.** Check for a short circuit diagnostic code while the new sensor is connected to the harness.

Expected Result:

The short circuit diagnostic code is not present when a new sensor is connected.

Results:

- OK – Verify that the repair eliminates the problem. Clear the logged diagnostic codes. **STOP.**

- Not OK

Repair: Repair the engine harness connector.

STOP.

Test Step 7. Check the Operation of the ECM by Creating Open and Short Circuits at the ECM Connector.

ENGINE HARNESS CONNECTOR P2

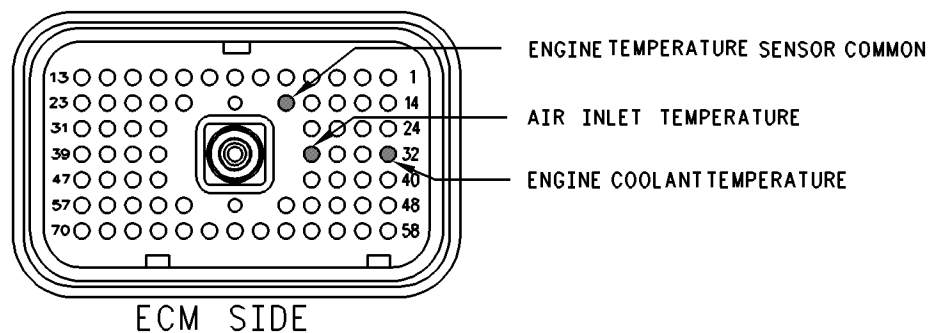

Illustration 97
Engine harness connector

g00767376

- A.** Turn the ignition key switch to the OFF position.
- B.** Disconnect the Connector for the ECM harness. Thoroughly inspect both halves of the connector for signs of corrosion or moisture.
- C.** Turn the ignition key switch to the ON position. Monitor the “Active Diagnostic Code” screen. Wait at least 15 seconds for activation of the code.

An open circuit diagnostic code should be active for the suspect sensor.

Note: When the engine harness is disconnected, all of the open circuit diagnostic codes for the pressure sensors will be active. This is normal. Disregard the diagnostic codes for the pressure sensors.

- D.** Turn the ignition key switch to the OFF position.
- E.** Fabricate a jumper wire 150 mm (6 inch) long. Crimp a Deutsch socket to both ends of the wire.
- F.** Install the jumper wire on the ECM pin terminal. Insert the jumper wire between the terminal for the suspect sensor signal and the common connection for the engine temperature sensor (terminal 18).

A short circuit diagnostic code should be active when the jumper wire is installed.

Note: If access to the ECM connector is limited, it may be helpful to connect a breakout T to the ECM connector. This will allow the jumper wire to be inserted into the breakout T. Ensure that the jumper wire is inserted into the breakout T and that the full wiring harness is attached.

Refer to Illustration 97 for the engine harness connector P2.

Expected Result:

Open circuit diagnostic codes are active when the jumper is removed. Short circuit diagnostic codes are active when the jumper is installed.

Results:

- **OK** – The ECM is working properly. Proceed to Test Step 8.
- **Not OK** – One of the following conditions exists:
The open circuit diagnostic code is not active when the harness is disconnected. The short circuit diagnostic code is not active when the jumper wire is installed.

Repair: Perform the following repair:

1. Temporarily connect a test ECM.
2. Remove all jumpers and replace all connectors.
3. Recheck the system for active diagnostic codes.
4. Repeat the test step.
5. If the problem is resolved with the test ECM, reconnect the suspect ECM.
6. If the problem returns with the suspect ECM, replace the ECM.
7. Verify that the repair eliminates the problem.

STOP.

Test Step 8. Bypass the Harness Wiring Between the ECM and the Sensor Connector.

- A. Turn the ignition key switch to the OFF position.
- B. Disconnect the connector for the ECM harness, and the sensor connector.
- C. Remove the sensor signal wire from the ECM connector.
- D. Remove the signal wire (terminal 1) from the sensor connector on the engine harness.
- E. Fabricate a jumper wire that is long enough to reach from the ECM to the sensor connector with Deutsch sockets on both ends.
- F. Insert one end of the jumper into the ECM Connector. Insert the other end of the jumper into the sensor connector of the engine harness.
- G. Reconnect the connector for the ECM harness and the sensor connector.
- H. Turn the ignition key switch to the ON position.
- I. Monitor the "Active Diagnostic Code" screen for either the open circuit diagnostic code for the sensor or the short circuit diagnostic code for the sensor.

Expected Result:

The diagnostic code disappears when the jumper is installed.

Results:

- OK – There is a problem in the wiring harness.

Repair: Perform the following repair:

1. Repair the faulty wiring harness or replace the faulty wiring harness.
2. Clear all diagnostic codes.
3. Verify that the repair eliminates the problem.

STOP.

- Not OK – Restart this procedure and carefully perform each step. STOP.

i01617893

Exhaust Brake Circuit - Test

SMCS Code: 1093-081

System Operation Description:

Use this procedure under the following situation:

Use this procedure to determine if the circuit for the exhaust brake (output 3) is operating correctly.

The following background information is related to this procedure:

The exhaust brake relay circuit is provided by the ECM. The circuit indicates that conditions are acceptable for an exhaust brake to operate. Operation of the exhaust brake is inhibited during undesirable engine operating conditions.

When the cruise control on/off switch is in the OFF position, the following conditions exist:

All of the following conditions must be met in order to ensure the proper operation of the exhaust brake:

- Engine speed is above 1000 rpm.
- The accelerator pedal position is less than seven percent.
- The clutch pedal is released.
- The switch for the exhaust brake is on.
- The PTO on/off switch is off.

When the cruise control on/off switch is in the ON position, the following conditions exist:

"Exhaust Brake Mode" Parameter

When the cruise control on/off switch is on, this parameter provides two special options that allow the exhaust brake to be operated only after the driver has depressed the service brake pedal. The two modes of operation that follow are customer programmable:

- The “Coast” mode engages the exhaust brake when the driver depresses the service brake pedal. The exhaust brake disengages when the driver releases the service brake pedal.
- The “Latch” mode engages the exhaust brake when the driver depresses the service brake pedal. The exhaust brake remains engaged until the control detects a change in the control input. The following actions are examples of a change in a control input:
 - The throttle is depressed.
 - The clutch pedal is depressed.
 - The engine speed drops below 900 rpm.

The third option for the Exhaust Brake Parameter is “Manual”. The “Manual” mode operates in the same manner regardless of the position of the cruise control on/off switch. The driver is not required to depress the service brake pedal in order to initiate the exhaust brake. Depress the service brake pedal in order to initiate the exhaust brake in the “Latch” mode and the “Coast” mode.

Note: The “Latch” mode and the “Coast” mode are customer programmable options. The “Latch” mode and the “Coast” mode determine the operation of the exhaust brake only when the cruise control switch is in the ON position. The “Latch” mode and the “Coast” mode do not determine the operation of the exhaust brake when the engine is active in cruise control. “Latch” mode and “Coast” mode require the initiation of the service brake before acting. The action of the service brake disengages the cruise control.

Note: The output for the exhaust brake is disabled whenever the PTO on/off circuit is on and the customer parameter “PTO Configuration” is programmed to “Cab Switches”, “Remote Switches”, or “Remote Throttle”.

Warm-up Mode

With OCT01 Software, the exhaust brake can be used to apply a parasitic load to the engine in order to aid engine warm-up. The exhaust brake will help the engine achieve normal operating temperatures. To use this feature, the parameter “Exhaust Brake Warm Up Configuration” must be programmed to “Warm Up Only” or “Exhaust Brake & Warm Up”. Also, the on/off switch for the exhaust brake must be in the ON position and the parameter “Exhaust Brake Switch” must be programmed to “J1/P1:16” or one of the J1939 options. The “Warm Up Mode Idle Speed” parameter must be programmed to an engine speed between 700 rpm and 1400 rpm. If the preceding conditions are met, the engine will ramp up to the engine rpm that is programmed into the “Warm Up Mode Idle Speed” parameter.

Warm up mode will terminate when the engine reaches normal operating temperatures or when one of the following conditions are met:

- The service brake is depressed.
- The clutch pedal is depressed.
- The exhaust brake switch is turned off.
- The vehicle is in gear.
- The throttle is depressed.
- The vehicle speed is greater than one mph.
- The ECM detects an excessive load on the engine.
- The engine rpm is less than 500 rpm. The engine rpm is greater than 1450 rpm.

Exhaust Brake On/Off Switch

An on/off switch can be used to provide operator control of the exhaust brake in order to inhibit operation during undesirable conditions. Two different methods may be used. An in-line switch can be installed in the output circuit for the exhaust brake (terminal 12). The switch will turn the brake off by opening the circuit. This removes power from the brake relay. Opening the switch does not disable the output driver. Opening the switch disables the exhaust brakes.

With NOV99 and newer Personality Modules, an optional feature was added in order to provide an input to the ECM. The input is used to connect an on/off switch for the exhaust brake. The input uses terminal 16. When the switch is opened, the ECM will turn off the output circuit for the exhaust brake. This method allows the ECM to broadcast the correct status of the exhaust brake over the data link. With the first method that is described above, the brake can be disabled but the output remains active.

Note: If the on/off switch for the exhaust brake is installed in the output circuit, the “Exhaust Brake Switch” parameter must be programmed to “NOT INSTALLED”. If the on/off switch is connected to the ECM switch input (terminal 16), the “Exhaust Brake Switch” parameter must be programmed to “INSTALLED”.

OCT01 Software

Note: If the on/off switch for the exhaust brake is installed in the output circuit, the “Exhaust Brake Switch” parameter must be programmed to “NONE”. If the on/off switch is connected to the ECM switch input (terminal 16), the “Exhaust Brake Switch” parameter must be programmed to “J1/P1:16”. If the J1939 data link is used to transmit the status of the on/off switch for the exhaust brake, the “Exhaust Brake Switch” parameter must be programmed to “Cab Controller”, “Body Controller”, or “Instrument Cluster”. If the parameter is programmed to one of the J1939 options, the switch status will be transmitted to the ECM over the J1939 data link. If a problem is suspected with the J1939 data link, refer to Troubleshooting, “Powertrain Data Link Circuit - Test”.

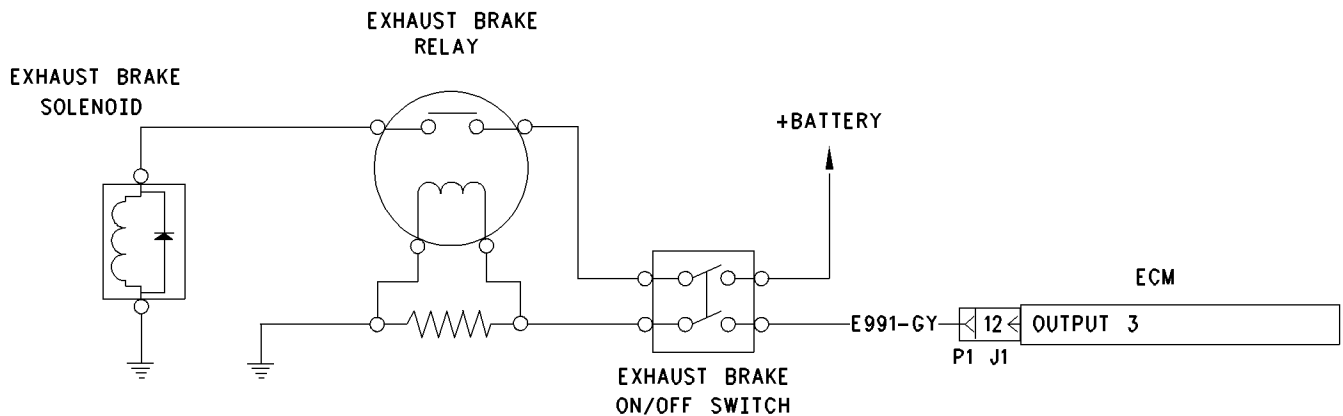

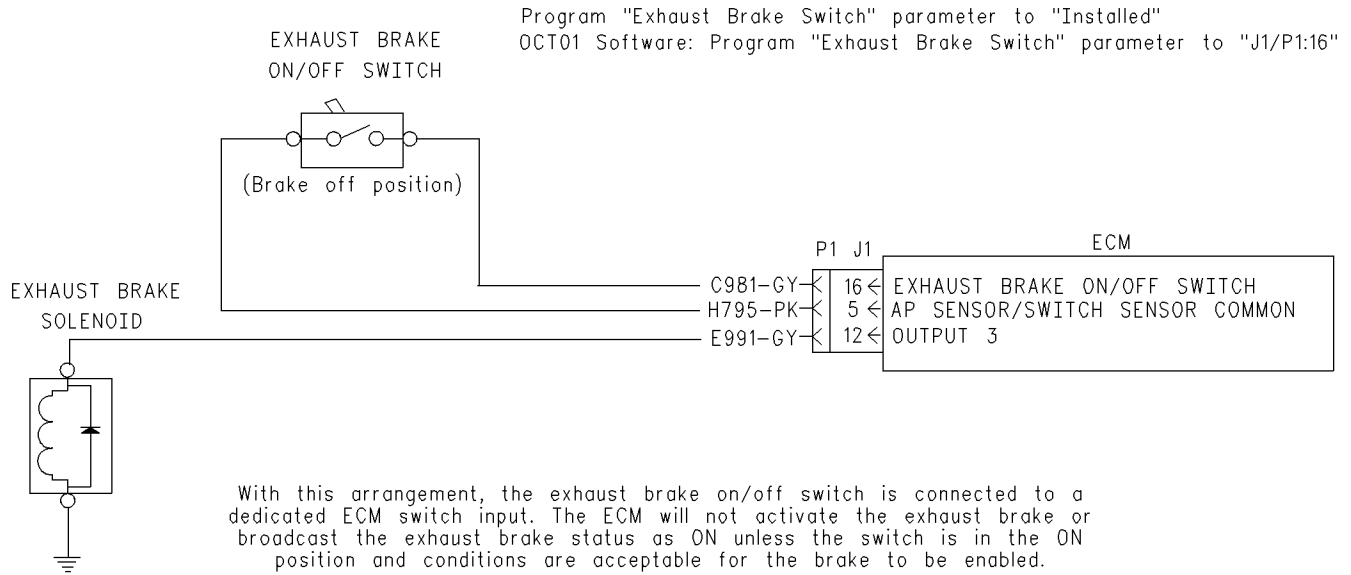

Illustration 99

g00837623

Schematic for the on/off switch that is connected to terminal 16

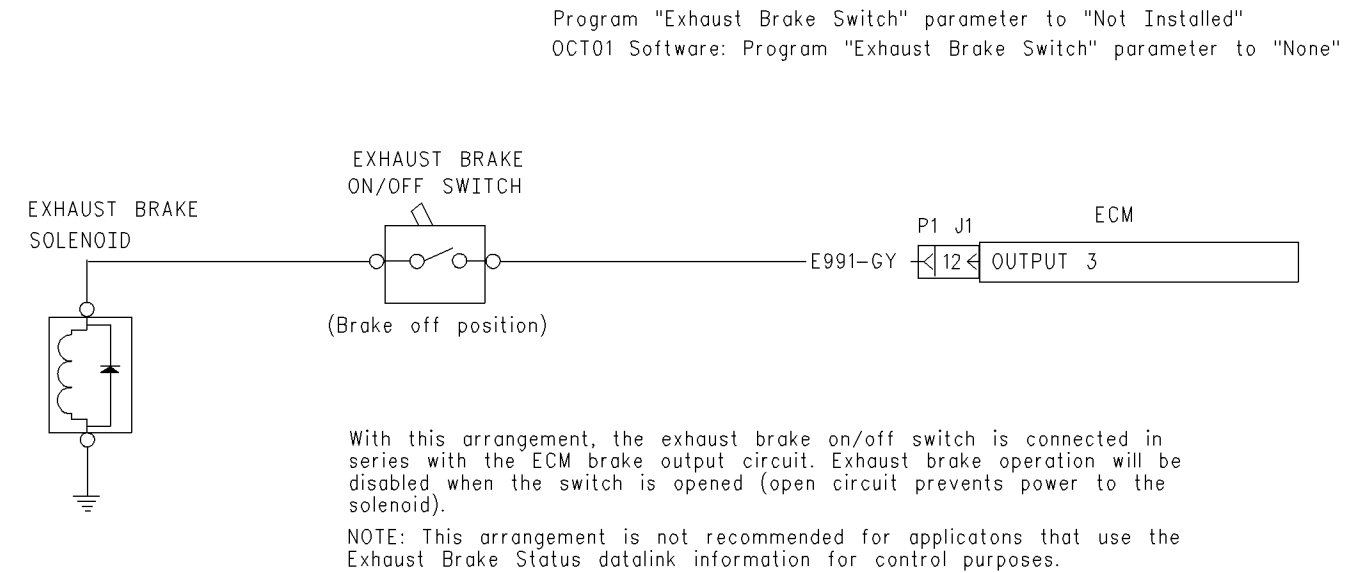

Illustration 100

g00837627

Schematic for the on/off switch that is connected in series with the output circuit

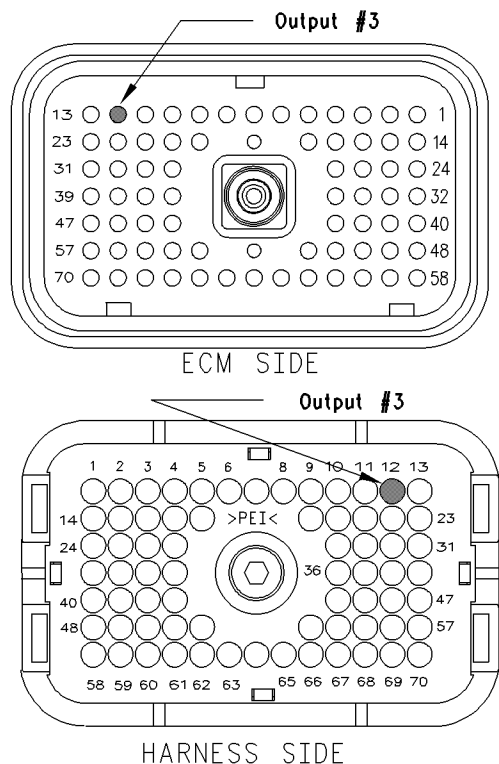

Illustration 101
ECM terminal

Test Step 1. Inspect Electrical Connectors and Wiring.

- A.** Thoroughly inspect ECM connectors J1/P1 and the firewall bulkhead connector. Refer to Troubleshooting, “Electrical Connectors - Inspect” for details.
- B.** Perform a 45 N (10 lb) pull test on each of the wires in the ECM connector that are associated with the connections for the circuit for the exhaust brakes.
- C.** Check the ECM connector (allen head screw) for the proper torque of 6.0 N·m (55 lb in).
- D.** Check the harness and wiring for abrasion and for pinch points from the sensor to the ECM.

Expected Result:

All connectors, pins, and sockets should be completely coupled and/or inserted and the harness and wiring should be free of corrosion, abrasion or pinch points.

Results:

- OK – Proceed to the Test Step 2.
- Not OK

Repair: Perform the following repair:

Repair the connectors or wiring and/or replace the connectors or wiring. Ensure that all of the seals are properly in place and ensure that the connectors are completely coupled.

Verify that the repair eliminates the problem.

STOP.

Test Step 2. Connect ET and Check the Accelerator Pedal Position Sensor and the Clutch Pedal Position Switch.

- A.** Ensure that the cruise control on/off switch is OFF.
- B.** Connect ET at the cab data link connector.
- C.** Turn the ignition key switch to the ON position.
- D.** Use the following procedure to check the accelerator pedal position sensor:
 - a.** Monitor the duty cycle of the throttle sensor on ET. Access the “Accelerator Pedal Position” display screen.
 - b.** While the duty cycle is being monitored on ET depress the accelerator pedal and release the accelerator pedal. Repeat this action several times.
- E.** If a manual transmission is installed, use the following procedure to check the status of the “Clutch Pedal Position Switch”:
 - a.** Access the status screen onET for the “Clutch Pedal Position Switch”.
 - b.** While the status screen is being monitored on ET, depress the clutch pedal and release the clutch pedal. Repeat this action several times.

Expected Result:

The duty cycle of the accelerator pedal position sensor is between 3 percent and 100 percent. The status of the “Clutch Pedal Position Switch” on ET changes from OFF to ON when the clutch pedal is depressed. The status of the “Clutch Pedal Position Switch” on ET changes from ON to OFF when the clutch pedal is released.

Results:

- OK – Proceed to Test Step 3.
- Not OK – Incorrect accelerator pedal position

Repair: Perform the following diagnostic procedure:

Troubleshooting, "Accelerator Pedal (Throttle) Position Sensor Circuit - Test".

STOP.

- Not OK – Clutch switch status is incorrect.

Repair: Perform the following diagnostic procedure:

Troubleshooting, "Clutch Pedal Position Switch Circuit - Test".

STOP.

Test Step 3. Connect ET and Check the Solenoids and the Relays.

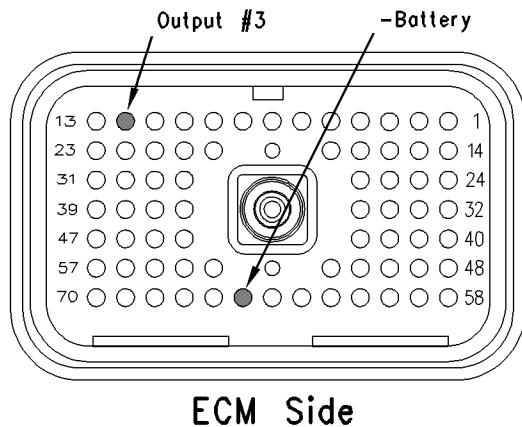

Illustration 102

g00769913

Breakout T

- Connect ET at the cab data link connector.
- Turn the ignition key switch to the ON position.
- Turn the switch ON for the exhaust brake.
- Access the status screen on ET for the "Exhaust Brake Special Test".
- Turn the on/off switch for the exhaust brake to the ON position.
- Begin the "Exhaust Brake Special Test" while you listen for the solenoids to click. You may need to be closer to the engine in order to hear the click of the solenoid.

Expected Result:

All of the solenoids and all of the relays are operating.

Results:

- Yes – The ECM is operating correctly. STOP.
- No – Proceed to Test Step 4.

Test Step 4. Use ET to Check the ECM.

- Turn the ignition key switch to the OFF position.
- Disconnect the ECM engine harness connector J1/P1.
- Connect a breakout T to the ECM connector J1/P1.
- Connect a voltage test lamp to terminal 12 (Output 3) and terminal 65 (-battery) of the 70-Terminal breakout T.
- Turn the ignition key switch to the ON position.
- Access the special test for the "Exhaust Brake Special Test" on ET.
- While the voltage test lamp is being observed, cycle the special test for the exhaust brake to the ON and OFF positions.
- Stop the special test.

Expected Result:

The voltage test lamp behaves in the following manner:

- The voltage test lamp turns on when the test is active.
- The voltage test lamp turns off when the test is not active.

Results:

- Yes – There is a problem in the harness.

Repair: Perform the following repair:

Repair the engine harness or replace the engine harness. Verify that the repair eliminates the problem.

STOP.

- **No** – Verify that the switch for the exhaust brake is on and verify that the ET status screen reflects this condition. If the ECM is reading the switch status change, temporarily connect a test ECM. Repeat this test step. If the problem is resolved with the test ECM, reconnect the suspect ECM. If the problem returns with the suspect ECM, replace the ECM.

Repair: Perform the following repair:

1. Temporarily connect a test ECM.
2. Remove all jumpers and replace all connectors.
3. Recheck the system for active diagnostic codes.
4. Repeat the test step.
5. If the problem is resolved with the test ECM, reconnect the suspect ECM.
6. If the problem returns with the suspect ECM, replace the ECM.
7. Verify that the repair eliminates the problem.

STOP.

The diagnostic module provides a way to alert the driver if the exhaust particulate filter becomes plugged. The module monitors exhaust temperature and exhaust back pressure. When the temperature or the pressure reaches a predetermined level, the diagnostic module closes a switch that is connected to the ECM at J1/P1:7 input 4 and J1/P1:18 input sensor common 1. When the switch is closed the ECM derates the engine and a warning light may be illuminated. When the engine is derated, the engine speed is limited to 1200 rpm and the vehicle speed is limited to 72 km/h (45 mph). Refer to System Operation, Testing and Adjusting, RENR1271 and Special Instruction, REHS1314, "Johnson Matthey CRTdm Interface Software Guide" if a problem is suspected with the diagnostic module.

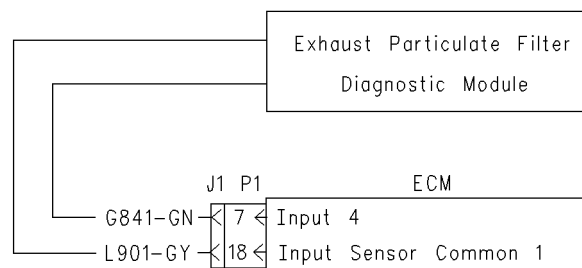

i01738942

Illustration 103

g00890690

Exhaust Particulate Filter Circuit - Test

SMCS Code: 1091-081

System Operation Description:

Use this procedure under the following situation:

Use this procedure to determine if the circuit for the diagnostic module is operating correctly.

The following background information is related to this procedure:

The ECM can use various inputs in a number of ways. The inputs depend on the parameter programming. Certain features are available on several different inputs. When an exhaust particulate filter is installed, the parameter "PTO Configuration" is automatically programmed to "Cab Switches". This parameter cannot be reprogrammed.

Diagnostic Module

Circuit schematic for the diagnostic module

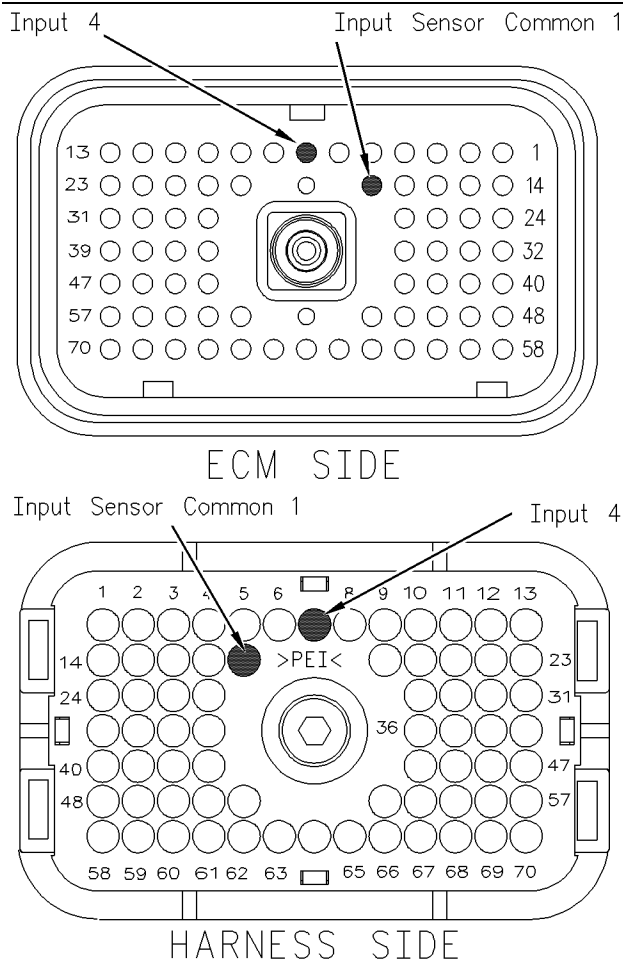

Illustration 104
 Terminal locations for ECM connector P1
 g00890806

Test Step 1. Inspect Electrical Connectors and Wiring

- A.** Thoroughly inspect the ECM vehicle harness connector J1/P1, the connectors, and the firewall bulkhead connectors. Refer to Troubleshooting, “Electrical Connectors - Inspect” for details.
- B.** Perform a 45 N (10 lb) pull test on each of the wires in the ECM connector that are associated with the torque limit switch.

The wires are on the following terminals:

- P1:7
- P1:18

- C.** Check the ECM connector (allen head screw) for the proper torque of 6.0 N·m (55 lb in).

- D.** Check the harness and the wiring for abrasion and pinch points from the battery to the ECM. Then, check from the ignition key switch to the ECM.

Refer to Illustration 104 for terminal locations for the ECM.

Expected Result:

All connectors, pins, and sockets are completely coupled and/or inserted, and the harness and wiring should be free of corrosion, abrasion or pinch points.

Results:

- OK – Proceed to Test Step 2.
- Not OK

Repair: Repair the wiring and connectors or replace the wiring or the connectors. Ensure that all of the seals are properly connected. Verify that the repair eliminates the problem.

STOP.

Test Step 2. Check the Switch Circuit for the ECM

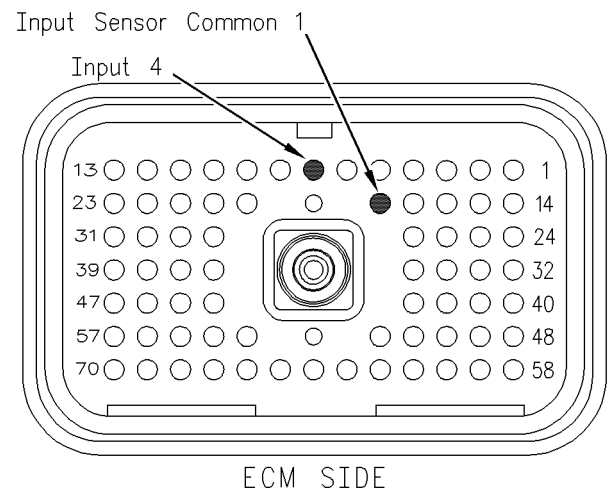

Illustration 105
 g00890896

- A.** Turn the ignition key switch to the OFF position.
- B.** Install a 140-2266 Cable breakout T to the ECM vehicle harness connector J1/P1.
- C.** Fabricate a jumper wire 100 mm (4 inch) long. Crimp a Deutsch pin to both ends of the wire.

- D. Insert the jumper wire into terminal 7 of the breakout T. Connect the other end of the jumper wire to terminal 18 in the breakout T. Terminal 18 is input sensor common 1.
- E. Connect Caterpillar Electronic Technician (Cat ET) to the cab data link connector.
- F. Turn the ignition key switch to the ON position.
- G. Alternately remove the jumper wire and then insert the jumper wire from terminal 18. At the same time, monitor the status screen on Cat ET.

Expected Result:

The input status changes to "ON" with the jumper wire in place. The input status changes to "OFF" when the jumper wire is removed.

Results:

- OK – The ECM is functioning properly at this time. Proceed to Test Step 3.
- Not OK – The ECM is not functioning properly.

Repair: Perform the following repair:

1. Temporarily connect a test ECM.
2. Remove all jumpers and replace all connectors.
3. Recheck the system for active diagnostic codes.
4. Repeat the Test Step.
5. If the problem is resolved with the test ECM, reconnect the suspect ECM.
6. If the problem returns with the suspect ECM, replace the ECM.
7. Verify that the repair eliminates the problem.

STOP.

Test Step 3. Insert a Jumper Wire at the Diagnostic Module

- A. Turn the ignition key switch to the OFF position.
- B. Reconnect the ECM vehicle harness connector J1/P1.
- C. Fabricate a jumper wire 100 mm (4 inch) long. Crimp a Deutsch pin to both ends of the wire.
- D. Insert the jumper wire between the two terminals at the diagnostic module.
- E. Turn the ignition key switch to the ON position.

- F. Alternately remove the jumper wire and then insert the jumper wire at the terminals on the diagnostic module. At the same time, watch the status screen on Cat ET.

Expected Result:

The input status changes to "ON" with the jumper wire in place. The input status changes to "OFF" when the jumper wire is removed.

Results:

- OK – The vehicle wiring is OK.

Repair: Refer to System Operation, Testing and Adjusting, RENR1271 and Special Instruction, REHS1314, "Johnson Mathey CRTdm Interface Software Guide" for troubleshooting the diagnostic module.

STOP.

- Not OK – The problem is in the vehicle wiring between the ECM and the diagnostic module.

Repair: Inspect the vehicle wiring and then repair the vehicle wiring. Otherwise, send the vehicle to the OEM dealer for repair. Verify that the original condition is resolved.

STOP.

i01479400

Fast Idle Enable Circuit - Test

SMCS Code: 1900-081

System Operation Description:**Use this procedure under the following situation:**

Use this procedure to determine if the fast idle switch is operating correctly.

The following background information is related to this procedure:

A fast idle switch (momentary switch) and a fast idle lamp can be installed. The operator can use the fast idle switch in either of the following ways:

- Press and release the fast idle switch in order to use the engine speed that is programmed into the "Fast Idle RPM #1" parameter.
- Use the accelerator pedal to accelerate the engine to the desired engine speed. Press and release the fast idle switch in order to maintain the engine speed at the desired engine speed.

A second programmable parameter “Fast Idle RPM #2” provides a second engine rpm set speed. The ECM will increase the engine speed from low idle to the engine speed that is programmed in the “Fast Idle RPM #1” parameter when the fast idle switch is pressed and then released. The ECM will set the engine speed to the rpm that is programmed in the “Fast Idle RPM #2” parameter when the fast idle switch is pressed and then released again.

Input 18 (terminal 40) is used as a dedicated switch input for fast idle operation. This feature does not require an input selection to be programmed to enable the switch input. A momentary connection between terminal 40 and a sensor common will initiate the fast idle operation. The “Fast Idle RPM #2” and/or “Fast Idle RPM #1” parameters must be programmed to the desired engine operating speeds.

The engine rpm set speed will not be maintained if any of the following actions occur:

- The service brake is depressed.
- The clutch pedal is depressed.
- The neutral switch indicates that the transmission is in gear.

An optional fast idle lamp can be connected to output 9 in order to indicate when fast idle is in operation. When the “Truck Manufacturer” parameter is configured to “Other”, the “Output #9” parameter must be programmed to “Fast Idle Lamp” to enable the lamp operation. If the “Output #9” parameter is programmed to “Wait to Start Lamp”, the lamp will turn on when the air inlet heater is active. When the “Truck Manufacturer” parameter is configured to “GM”, output 9 can only be used as a fast idle lamp output, and no programming is necessary.

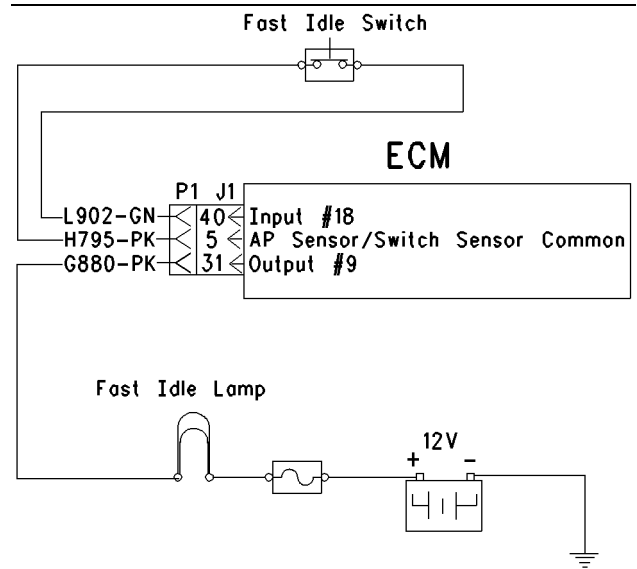

Illustration 106

g00770407

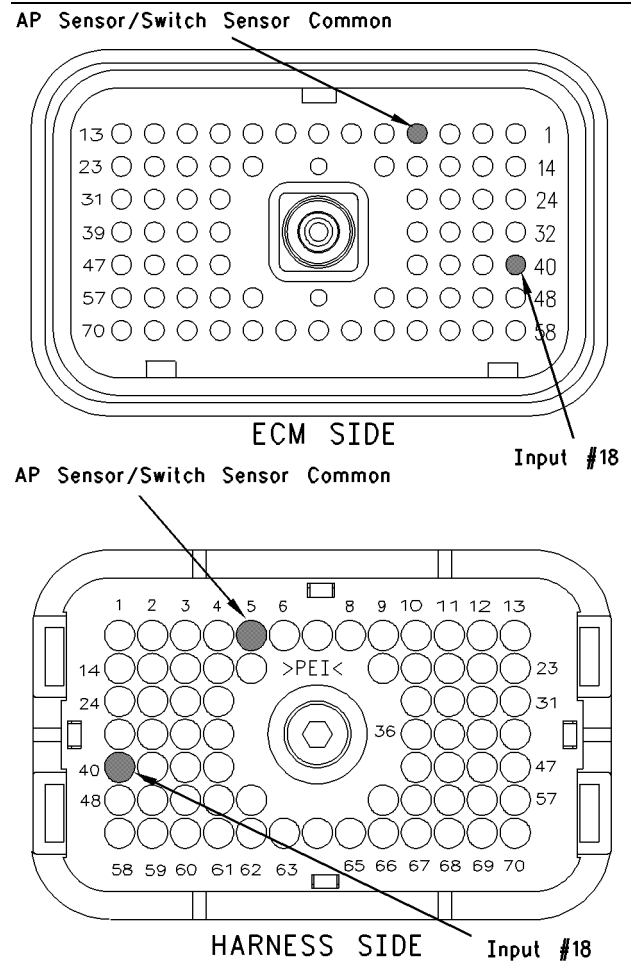

Illustration 107

g00770414

Test Step 1. Check The Electrical Connectors and The Wiring

- A. Thoroughly inspect the ECM vehicle harness connector J1/P1, terminal 40, and the firewall bulkhead connectors. Refer to Troubleshooting, "Inspecting Electrical Connectors" for details.
- B. Perform a 45 N (10 lb) pull test on each of the wires in the ECM connector that are associated with the fast idle switch circuit.

The wires are on the following terminals:

- terminal 40
- terminal 5

- C. Check the ECM connector (allen head screw) for the proper torque of 6.0 N·m (55 lb in).
- D. Check the harness and the wiring for abrasion and pinch points from the battery to the ECM. Then, check from the ignition key switch to the ECM.

Refer to Illustration 107 for terminal locations for the ECM.

Expected Result:

All connectors, pins, and sockets are completely coupled and/or inserted, and the harness and wiring should be free of corrosion, abrasion or pinch points.

Results:

- OK – Proceed to Test Step 2.
- Not OK – Repair the wiring and connectors or replace the wiring or the connectors. Ensure that all of the seals are properly connected. Verify that the repair eliminates the problem. STOP.

Test Step 2. Check the Status of the Fast Idle Switch On The Electronic Service Tool.

- A. Connect an Electronic Service Tool at the cab data link connector.
- B. Turn the ignition key switch to the ON position.
- C. Operate the switch in the ON position and the OFF position.
- D. View the "Fast Idle Switch" status on the Electronic Service Tool.

Note: A fast idle rpm must be programmed in order to automatically go to a set speed.

Expected Result:

The status screen should indicate "ON" if the switch is turned on. The status screen should indicate "OFF" if the switch is off.

Results:

- YES – The switch is operating normally. Continue troubleshooting if the original condition is not resolved. STOP.
- NO – The ECM is not reading the "Switch Status" change. Proceed to Test Step 3.

Test Step 3. Check The Switch Circuit for the ECM.

AP Sensor/Switch Sensor Common

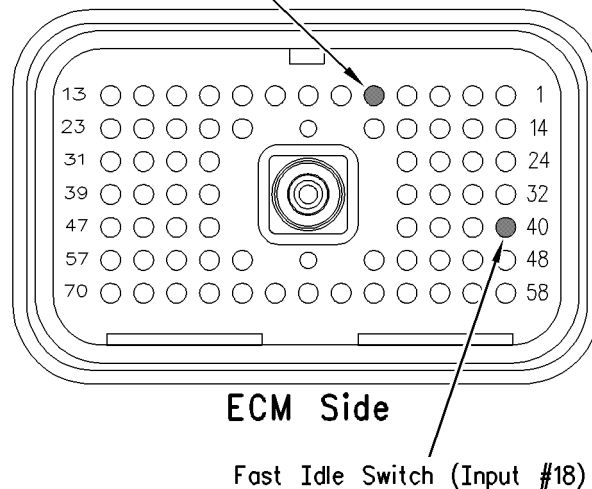

Illustration 108

g00770457

- A. Turn the ignition key switch to the OFF position.
- B. Install a 70 terminal breakout T to the ECM vehicle harness connector J1/P1.
- C. Fabricate a jumper wire 100 mm (4 inch) long. Crimp a Deutsch pin to both ends of the wire.
- D. Insert the jumper wire into terminal 40 of the breakout T. Connect the other end of the jumper wire to terminal 5 in the breakout T. Terminal 5 is AP sensor/switch common.
- E. Connect an Electronic Service Tool at the cab data link connector.
- F. Turn the ignition key switch to the ON position.
- G. Alternately remove the jumper wire and then insert the jumper wire from terminal 5. At the same time, monitor the "Status Screen" on the Electronic Service Tool.

Expected Result:

The “Switch Status” changes to “ON” with the jumper wire in place. The “Switch Status” changes to “OFF” when the jumper wire is removed.

Results:

- **Yes** – The ECM is functioning properly at this time. Proceed to Test Step 4.
- **No** – The ECM is not functioning properly.

Repair: Perform the following repair:

1. Temporarily connect a test ECM.
2. Remove all jumpers and replace all connectors.
3. Recheck the system for Active diagnostic codes.
4. Repeat the test step.
5. If the problem is resolved with the test ECM, reconnect the suspect ECM.
6. If the problem returns with the suspect ECM, replace the ECM.
7. Verify that the repair eliminates the problem.

STOP.

Test Step 4. Insert a Jumper Wire at the Switch.

- A.** Turn the ignition key switch to the OFF position.
- B.** Reconnect the ECM vehicle harness connector J1/P1.
- C.** Fabricate a jumper wire 100 mm (4 inch) long. Crimp a Deutsch pin to both ends of the wire.
- D.** Insert the jumper wire between the two switch terminals of the fast idle switch.
- E.** Turn the ignition key switch to the ON position.
- F.** Alternately remove the jumper wire and then insert the jumper wire at the switch terminals. At the same time, watch the “Status Screen” on the Electronic Service Tool.

Expected Result:

The “Switch Status” changes to “ON” with the jumper wire in place. The “Switch Status” changes to “OFF” when the jumper wire is removed.

Results:

- **YES**

Repair: Perform the following diagnostic procedure:

Replace the fast idle switch.

Verify that the repair eliminates the problem.

STOP.

- **NO** – There is a problem in the wire harness between the fast idle switch and the ECM. Proceed to Test Step 5.

Test Step 5. Insert A Jumper Wire At The Bulkhead Connector.

- A.** Turn the ignition key switch to the OFF position.
- B.** Fabricate a jumper wire 100 mm (4 inch) long. Crimp a Deutsch pin to both ends of the wire.
- C.** Locate the socket for the fast idle switch in the engine side of the bulkhead connector for the wiring to the ECM.
- D.** Insert the wire jumper pin between the switch socket and the sensor common connection. Install the jumper wire on the engine side of the bulkhead connector for the wiring to the ECM.
- E.** Turn the ignition key switch to the ON position.
- F.** Alternately connect and then disconnect the jumper wire. At the same time, monitor the “Status Screen” on the Electronic Service Tool.

Expected Result:

The “Switch Status” changes from “ON” with the jumper wire in place. The “Switch Status” changes to “OFF” when the jumper wire is removed.

Results:

- **YES** – The problem is in the vehicle wiring between the bulkhead connector and the switch. Inspect the vehicle wiring and then repair the vehicle wiring. Otherwise, send the vehicle to the OEM dealer for repair. Verify that the original condition is resolved. **STOP.**
- **NO** – The problem is in the vehicle wiring between the bulkhead connector and the ECM. Inspect the vehicle wiring and then repair the vehicle wiring. Otherwise, send the vehicle to the OEM dealer for repair. Verify that the original condition is resolved. **STOP.**

i01606728

Fast Idle Lamp Circuit - Test

SMCS Code: 1900-081

System Operation Description:

Use this procedure under the following situation:

Personality Modules that have a Software Date Code dated earlier than OCT01.

Use this procedure to determine if the fast idle lamp (P1:31 output 9) is operating properly.

Output 9 can operate as a fast idle lamp or a wait to start lamp. The "Output #9" parameter defaults to "Fast Idle Lamp" and the ECM will turn on output 9 when the fast idle is active.

Note: For "GM Truck Manufacturer" configurations, the "Output #9" parameter is unavailable and output 9 functions as an output only for the fast idle lamp.

Electrical Connections of the Lamp

One terminal of the lamp must be connected to battery voltage through the vehicle wiring. The other terminal is connected to the ECM at the vehicle harness connector P1:31.

The ECM provides a path to ground that will turn on the lamp.

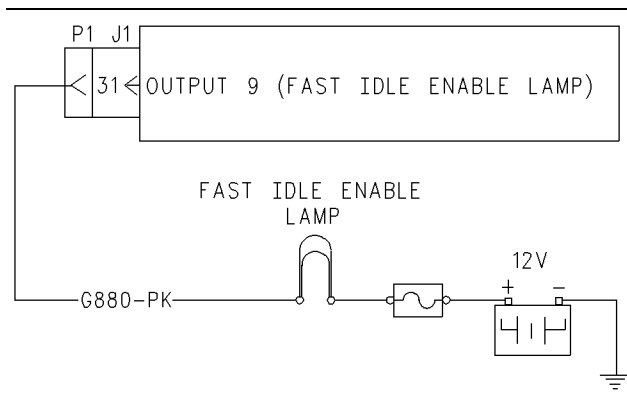

Illustration 109

g00832955

Schematic for the fast idle enable switch

OCT01 Software

OCT01 and newer Personality Module Software also offers an alternative output that can be used for a fast idle lamp. The parameter "Output #9" is not used in the OCT01 software. The parameter "Fast Idle Lamp" has been added. "Fast Idle Lamp" can be programmed to "J1/P1:31" output 9, "J1/P1:21" output 8, or "None".

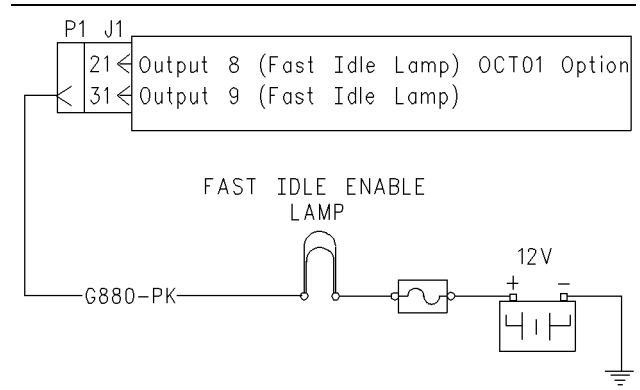

Illustration 110

g00834354

Schematic for the fast idle enable switch (OCT01 Option)

Test Step 1. Inspect Electrical Connectors and Wiring.

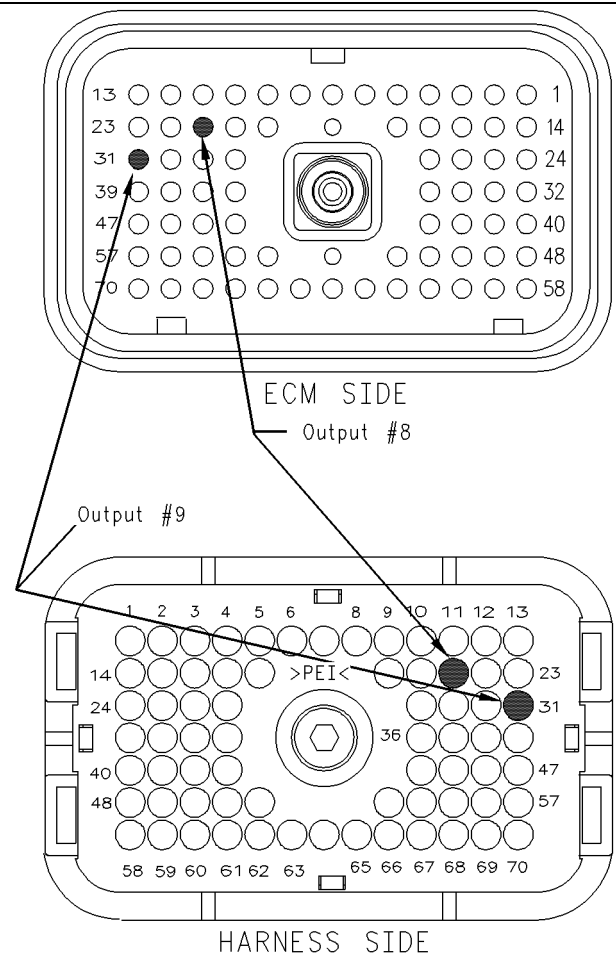

Illustration 111

g00834349

Location of Output 8 and Output 9

- A.** Thoroughly inspect ECM vehicle harness connector J1/P1, the firewall bulkhead connector, and the terminals for the fast idle lamp.

Refer to Troubleshooting, "Electrical Connectors - Inspect" for details.

- B.** Perform a 45 N (10 lb) pull test on each of the wires in the ECM connector that are associated with the fast idle lamp.
- C.** Check the ECM connector (allen head screw) for the proper torque of 6.0 N·m (55 lb in).
- D.** Check the harness and wiring for abrasion and for pinch points from the sensor to the ECM.

Expected Result:

All connectors, pins, and sockets should be completely coupled and/or inserted and the harness and wiring should be free of corrosion, abrasion or pinch points.

Results:

- OK – Proceed to Test Step 2.
- Not OK

Repair: Repair the connectors or wiring and/or replace the connectors or wiring. Ensure that all of the seals are properly in place and ensure that the connectors are completely coupled.

Verify that the repair eliminates the problem.

STOP.

Test Step 2. Check for Normal Operation of the Fast Idle Lamp.

- A.** Verify that a fast idle enable switch is installed.
- B.** Connect ET.
- C.** Turn the ignition key switch to the ON position.
- D.** Access the ET status screen. Verify that the following switches indicate the correct status:

- The service brake switch 1 is off.
- The service brake switch 2 is off.
- The neutral switch is on.
- The clutch switch is off.

If any of the switches do not display the indicated status, fast idle will not activate.

- E.** Use the ET status screen to monitor the fast idle switch and the fast idle rpm.

- F.** Depress the fast idle switch while the status of the fast idle enable switch is being observed. Also observe the fast idle lamp. Release the fast idle switch. The fast idle lamp should turn on when the fast idle switch is pressed and released.
- G.** Depress the service brake pedal. The fast idle lamp should turn off when the service brake is applied.

Expected Result:

The switch status changes per the above information. The fast idle lamp turns on and the fast idle lamp turns off per the description above.

Results:

- Yes – The fast idle lamp is operating normally. STOP.
- No – The ECM is not reading the switch status change. Proceed to Test Step 3.

Test Step 3. Test the Fast Idle Lamp Circuit.

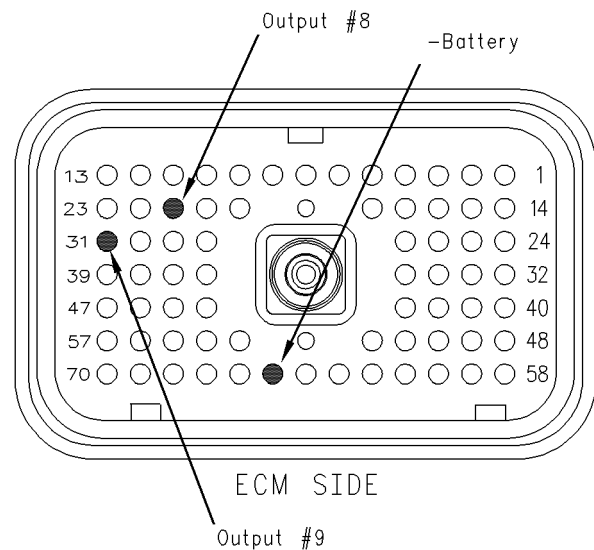

Illustration 112
 Pin locations

g00834351

- A.** Turn the ignition key switch to the OFF position.
- B.** Fabricate a jumper wire 100 mm (4 inch) long. Crimp a Deutsch pin to both ends of the wires.
- C.** Disconnect vehicle harness connector P1 from the ECM.
- D.** Insert the jumper into P1:31.

Note: For OCT01 and newer Personality Module Software, insert the jumper into P1:31 or P1:21. The terminal location depends on the programming of the "Fast Idle Lamp" parameter.

- E.** Connect the other end of the jumper wire to P1:65 (-battery).
- F.** Turn the ignition key switch to the ON position.
- G.** While the lamp is being watched, insert the jumper wire and remove the jumper wire.

Expected Result:

Result 1 The fast idle lamp turns on while the jumper is connected to both sockets. Also, the fast idle lamp turns off when the jumper is removed from one of the sockets.

Result 2 The fast idle lamp does not turn on while the jumper is connected to both sockets.

Result 3 The fast idle lamp will stay on while the ECM vehicle harness connector is disconnected.

Results:

- **Result 1** – The fast idle lamp is functioning properly. Proceed to Test Step 4.
- **Result 2** – The fast idle lamp did not turn on. The vehicle's lamp circuit is not functioning properly. The lamp is probably burned out or there is a problem in the wiring from the cab to either the ECM or the +battery connection. Repair the lamp circuit or send the vehicle to the OEM dealer for repairs. **STOP.**
- **Result 3**

Repair: Perform the following diagnostic procedure:

The circuit between the ECM and the lamp is shorted to chassis ground. Repair the circuit or send the vehicle to the OEM dealer for repairs.

STOP.

Test Step 4. Check ECM Operation of the Fast Idle Lamp.

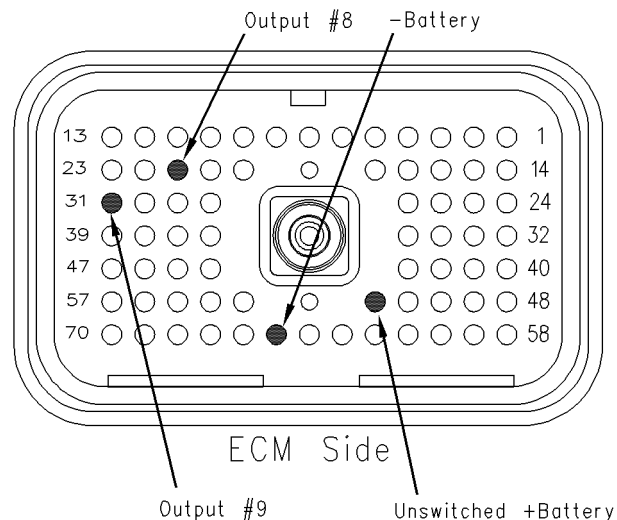

Illustration 113

g00834353

Pin locations on the Breakout T

- A.** Disconnect ECM vehicle harness connector J1/P1.
- B.** Insert a breakout T between ECM vehicle harness connector J1 and ECM vehicle harness connector P1.
- C.** Connect one probe of the voltage test lamp to P1:65 (-battery). Connect the other probe of the voltage test lamp to P1:52 (unswitched +battery) of the breakout T.
- D.** The test lamp should turn on. If the test lamp does not turn on, either the test lamp is faulty or the wiring to the ECM is faulty. Continue with this step if the lamp turns on.
- E.** Leave the probe of the test lamp connected to P1:52 (unswitched +battery).
- F.** Connect the other probe of the test lamp to P1:31 (output 9) of the breakout T.

Refer to Illustration 113.

- G.** Connect an ET. Access the following display screens in order:
 - Diagnostics
 - Diagnostic Test
 - Special Test

- H.** Activate the “Fast Idle Enabled Lamp” test. Observe the voltage test lamp. The lamp should turn on when the test is active. Also, the lamp should turn off when the test is inactive.

Expected Result:

The test lamp turns on and the test lamp turns off per the above description.

Results:

- **Yes** – The ECM is operating correctly. There is a problem in the vehicle wiring or the lamp. **STOP.**
- **No**

Repair: Temporarily connect a test ECM. Check the ECM operation of the fast idle lamp when the test ECM is installed. If the problem is resolved with the test ECM, reconnect the suspect ECM. If the problem returns with the suspect ECM, replace the ECM.

STOP.

The fuel level sensors are OEM installed components for the vehicle. The sensors are selectable through a Customer Programmable Parameter and the Customer Programmable Parameter may be protected by Customer Passwords.

The sensors read the level of fuel in the primary fuel tank and secondary fuel tank. The sensors require a +5 VDC supply from the ECM. The customer programmable parameters “Primary Fuel Tank Size” and “Secondary Fuel Tank Size” must be programmed to “25”, “35”, or “50” for this feature to work.

i01631206

Fuel Level Sensor Circuit - Test

SMCS Code: 7483-081-NS

System Operation Description:

Use this procedure under the following situation:

This feature is only available on GMT-560 applications.

Use this procedure to troubleshoot the system only when there is an active diagnostic code or when a diagnostic code can easily be activated. This procedure covers open circuit diagnostic codes and short circuit diagnostic codes that are associated with the fuel level sensors.

- 96-03 Primary Fuel Level Sensor Open Circuit (44)
- 96-04 Primary Fuel Level Sensor Short Circuit (44)
- 128-03 Secondary Fuel Level Sensor Open Circuit (44)
- 128-04 Secondary Fuel Level Sensor Short Circuit (44)

The following background information is related to this procedure:

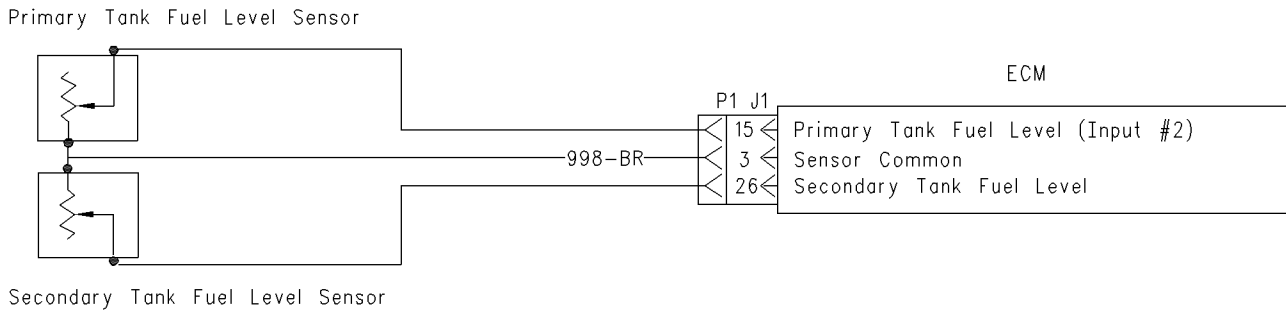

Illustration 114

g00844899

Circuit schematic for the fuel level sensors

Test Step 1. Inspect Electrical Connectors And Wiring.

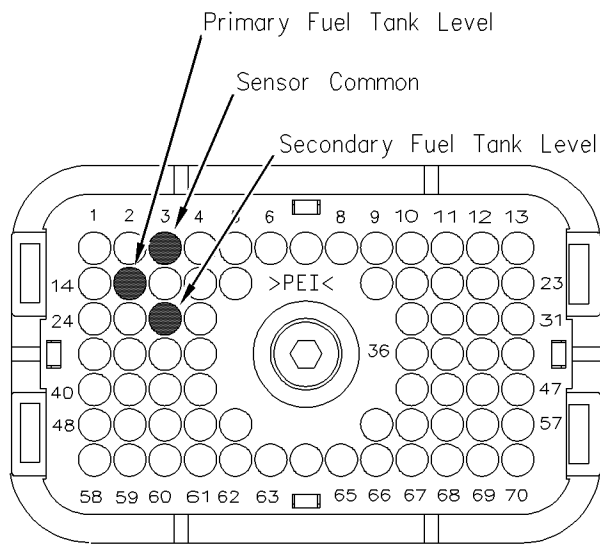

Illustration 115

g00844988

Terminal locations for ECM

- A. Thoroughly inspect ECM vehicle harness connector J1/P1 and the terminals for the fuel level sensors in the connectors. Refer to Troubleshooting, “Electrical Connectors-Inspect” for details.
- B. Perform a 45 N (10 lb) pull test on each of the wires in the ECM connector that are associated with the following connections:
 - terminal 3
 - terminal 15
 - terminal 26

Refer to Illustration 115.

- C. Check the ECM connector (allen head screw) for the proper torque of 6.0 N·m (55 lb in).
- D. Check the harness and wiring for abrasion and pinch points from the sensors to the ECM.

Expected Result:

All connectors, pins and sockets should be completely coupled and/or inserted and the harness and wiring should be free of corrosion, abrasion or pinch points.

Results:

- OK – Proceed to Test Step 2.
- Not OK

Repair: Repair the connectors or wiring and/or replace the connectors or wiring. Ensure that all of the seals are properly in place and ensure that the connectors are completely coupled.

Verify that the repair eliminates the problem. Clear all diagnostic codes.

STOP.

Test Step 2. Verify that the Diagnostic Code is Still Active.

- A. Connect Caterpillar Electronic Technician (ET) to the cab data link connector.
- B. Turn the ignition key switch to the ON position. Wait at least 15 seconds for activation of the diagnostic codes.
- C. Monitor the “Active Diagnostic Code” screen of ET. Check and record active diagnostic codes.
- D. Determine if the problem is related to an open circuit diagnostic code or a short circuit diagnostic code.

Expected Result:

Either a short circuit diagnostic code is active or an open circuit diagnostic code is active.

Results:

- **SHORT Circuit** – A short circuit diagnostic code is active at this time. Proceed to Test Step 3.
- **OPEN Circuit** – An open circuit diagnostic code is active at this time. Proceed to Test Step 4.

Test Step 3. Disconnect the Sensor in order to Create an Open Circuit.

- A. Turn the ignition key switch to the OFF position.
- B. Disconnect the sensor connector of the sensor with the short circuit diagnostic code.
- C. Turn the ignition key switch to the ON position. Wait at least 15 seconds for activation of the diagnostic codes.
- D. Access the “Active Diagnostic Code” screen on ET. Check for an active open circuit diagnostic code.

Expected Result:

An open circuit diagnostic code for the disconnected sensor is now active.

Results:

- **OK** – A short circuit diagnostic code was active before disconnecting the sensor. An open circuit diagnostic code became active after disconnecting the sensor. Proceed to Test Step 5.
- **Not OK** – There is a short circuit between the sensor harness connector and the ECM. Leave the sensor disconnected. Proceed to Test Step 7.

Test Step 4. Measure the Sensor Supply Voltage.

- A. Turn the ignition key switch to the OFF position.
- B. Disconnect the sensor from the harness at the fuel tank.
- C. Turn the ignition key switch to the ON position.
- D. Set a multimeter to the “VDC” setting. Measure the voltage between the two terminals.

Expected Result:

The DC voltage measures 4.5 to 5.5 VDC.

Results:

- **OK** – The sensor supply voltage is correct. Proceed to Test Step 6.
- **Not OK** – The sensor supply voltage is out of range. Continue testing the sensor supply circuit. Proceed to Test Step 7.

Test Step 5. Determine if the Short Circuit is in the Connector or in the Sensor.

- A. Thoroughly inspect the connector for moisture.
- B. Inspect the seals and reconnect the sensor.
- C. If the short circuit diagnostic code reappears, the sensor or the harness connector is the problem.
 - a. Temporarily connect a new sensor to the harness.
- D. Check for a short circuit diagnostic code while the new sensor is connected to the harness.

Expected Result:

The short circuit diagnostic code is not present when a new sensor is connected.

Results:

- **OK** – Verify that the repair eliminates the problem. Clear the logged diagnostic codes. **STOP**.
- **Not OK** – Repair the engine harness connector. **STOP**.

Test Step 6. Create a Short Circuit Between the Supply and the Common Terminals at the Vehicle Harness Connector.

- A. Turn the ignition key switch to the ON position.
- B. Fabricate a jumper wire 150 mm (6 inch) long. Crimp a Deutsch terminal to both ends of the wire.
- C. Monitor the “Active Diagnostic Code” screen before installing the jumper wire and after installing the jumper wire.
- D. Install the jumper on the engine harness connector. Install one end of the jumper at the sensor supply P1:15 or P1:26. Install the other end of the jumper at the common connection for the sensor P1:3. Wait at least 15 seconds for activation of the short circuit diagnostic code.

Expected Result:

A short circuit diagnostic code is active when the jumper is installed. An open circuit diagnostic code is active when the jumper is removed.

Results:

- OK – The engine harness and the ECM are OK.

Repair: Perform the following repair:

1. Temporarily connect the suspect sensor.
2. If the diagnostic code remains active, replace the sensor.
3. Ensure that the diagnostic code is no longer active.
4. Verify that the repair eliminates the problem.

STOP.

- Not OK – The open circuit diagnostic code remains active when the jumper is installed. The most probable location for the open is in the sensor common or in the sensor supply in the vehicle harness between the ECM and the sensor. Remove the jumper. Proceed to Test Step 7.

Test Step 7. Check the Operation of the ECM by Creating Open and Short Circuits at the ECM Connector.

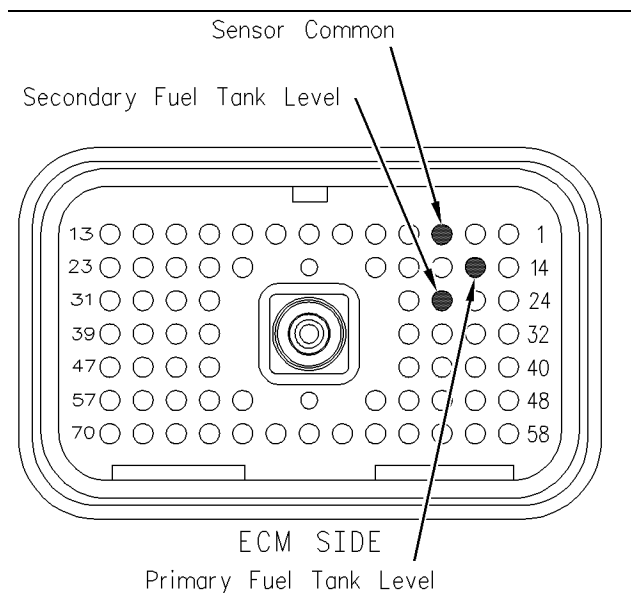

Illustration 116
Breakout T

g00846127

- B. Disconnect ECM engine harness connector J1/P1. Thoroughly inspect both halves of the connector J1/P1 for signs of corrosion or moisture. Reconnect engine harness connector J1/P1.

- C. Turn the ignition key switch to the ON position. Monitor the “Active Diagnostic Code” screen. Wait at least 15 seconds for activation of the code.

An open circuit diagnostic code should be active for the suspect sensor.

- D. Turn the ignition key switch to the OFF position.

- E. Disconnect ECM engine harness connector J1/P1. Install a breakout T.

- F. Fabricate a jumper wire 150 mm (6 inch) long. Crimp a Deutsch Socket to both ends of the wire.

- G. Install the jumper wire on the breakout T. Insert the jumper wire between the terminal for the suspect sensor supply and the common connection for the sensor.

A short circuit diagnostic code should be active when the jumper wire is installed.

Refer to Illustration 116 for the breakout T.

Expected Result:

Open circuit diagnostic codes and short circuit diagnostic codes were active.

Results:

- OK – The ECM is operating properly. Proceed to Test Step 8.
- Not OK – One of the following conditions exists: The open circuit diagnostic code is not active when the harness is disconnected. The short circuit diagnostic code is not active when the jumper wire is installed.

Repair: Perform the following repair:

1. Temporarily connect a test ECM.
2. Remove all jumpers and replace all connectors.
3. Recheck the system for active diagnostic codes.
4. Repeat the Test Step.
5. If the problem is resolved with the test ECM, reconnect the suspect ECM.

- A. Turn the ignition key switch to the OFF position.

6. If the problem returns with the suspect ECM, replace the ECM.
7. Verify that the repair eliminates the problem.

STOP.

Test Step 8. Bypass the Harness Wiring Between the ECM and the Sensor Connector.

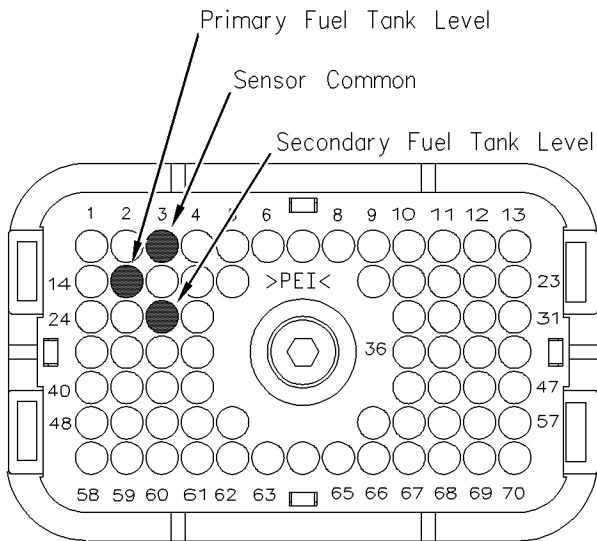

Illustration 117 g00844988
Terminal locations for ECM connector P1

- A. Turn the ignition key switch to the OFF position.
- B. Disconnect ECM vehicle harness connector J1/P1, and the sensor connector.
- C. Remove the wire for the sensor supply and the wire for the sensor common from ECM connector P1 on the harness.
- D. Remove the wire for the sensor supply and the wire for the sensor common from the sensor connector on the harness.
- E. Fabricate jumper wires that are long enough to reach from the ECM to the sensor connector.
- F. Insert the jumper wires into the ECM connector P1 on the vehicle harness. Insert the other end of the wires into the sensor connector of the vehicle harness.
- G. Reconnect ECM vehicle harness connector J1/P1 and the sensor connector.
- H. Turn the ignition key switch to the ON position.

- I. Monitor the “Active Diagnostic Code” screen for either the open circuit diagnostic code for the sensor or the short circuit diagnostic code for the sensor.

Expected Result:

The diagnostic code disappears when the jumper is installed.

Results:

- OK – There is a problem in the wiring harness.
Repair: Perform the following repair:
 1. Repair the faulty wiring harness or replace the faulty wiring harness.
 2. Clear all diagnostic codes.
 3. Verify that the repair eliminates the problem.

STOP.

- Not OK – Restart this procedure and carefully perform each step. STOP.

i01618462

Idle Shutdown Timer - Test

SMCS Code: 1900-081

System Operation Description:

Use this procedure under the following situation:

Use this procedure to determine if the idle shutdown timer is operating correctly.

The following background information is related to this procedure:

Idle Shutdown Timer

The idle shutdown timer is intended to improve fuel economy by limiting idling time.

The idle shutdown timer is a Customer Specified Parameter that may be programmed for any period from 3 to 1440 minutes.

The timer is activated when all of the following conditions are met regardless of the position of the parking brake:

- The vehicle speed is 0.

- The engine is not in Cold Mode or Dedicated PTO Mode.
- The engine is not under load.

The timer can be reset by moving the vehicle or the timer can be reset by quickly depressing the accelerator pedal and releasing the accelerator pedal.

The check engine lamp will begin to rapidly flash 90 seconds before the programmed time expires. During this 90 second time period, the following conditions can disable the timer:

- The clutch pedal is depressed.
- The service brake pedal is depressed.

The following event code will be logged when the driver overrides the timer by using the clutch pedal or the brake pedal during the 90 second period:

- 71-00 Idle Shutdown Override (01)

If the parameter “Allow Idle Shutdown Override” is programmed to “NO”, the timer can not be overridden by using the clutch pedal or the brake pedal during the final 90 second period. The factory default that is programmed for “Allow Idle Shutdown Override” is “YES”. This setting allows the timer to be overridden.

If the timer is activated and the timer is allowed to shut down the engine the following event code will be generated:

- 71-01 Idle Shutdown Occurrence (47)

Code 71-01 records the event and the code does not indicate an electrical system malfunction or an electronic system malfunction. Disable the timer by programming “Idle Shutdown Time” to 0 (Caterpillar Factory Default).

The ECM will shut down the engine but not the vehicle electrical system when the time that is programmed in “Idle Shutdown Timer” expires. The “Engine Shutdown Output” can be used to shut down the vehicle electrical system after the time has expired.

The idle shutdown timer can be temporarily disabled by using ET. The idle shutdown timer can be temporarily disabled through the “System Troubleshooting” screen which can be found by selecting “Diagnostic Tests” under the “Diagnostics” menu. Select “Idle Shutdown Timer” and click the “Change” icon. When the dialog box appears, change the value to “OFF”. Temporarily disabling this feature avoids engine shutdowns when you are troubleshooting other systems. Using this method eliminates the need to temporarily alter the Customer Specified Parameter “Idle Shutdown Timer”.

Note: If the following diagnostic code is active, the idle shutdown timer will not operate.

- 84-08 Vehicle Speed Out Of Range (36)

Test Step 1. Verify Activation of the Idle Shutdown Timer.

- A.** Connect ET to the cab data link connector.
- B.** Access the Customer Parameters on ET.
 - a.** Access the following display screens in order:
 - “Service”
 - “Configuration”
 - b.** Record the programmed time for the “Idle Shutdown Time”. The “Idle Shutdown Time” must be between 3 and 1440 minutes. If the “Idle Shutdown Time” is programmed to 0, then the timer is disabled.
 - c.** Record the current value of the parameter “Allow Idle Shutdown Override” and the parameter “Idle RPM Limit”.
- C.** Start the engine. Allow the engine to warm up until the coolant temperature is 38 °C (100 °F). Allow the engine to operate at the programmed low idle.
- D.** Ensure that all unnecessary loads are turned OFF.
 - a.** Park the vehicle.
 - b.** Ensure that “Vehicle Speed” on the ET status screen is 0 km/h (0 mph).
 - c.** Ensure that “Engine Speed” on the ET status screen is at “Low Idle”.
 - d.** Ensure that the clutch pedal and the brake pedal are not depressed.
 - e.** Ensure that the status of the “PTO On/Off Switch” is OFF.

- f. Observe the “Idle Shutdown Status”.

Expected Result:

Result 1 The “Idle Shutdown Status” indicates “Counting”.

Result 2 The “Idle Shutdown Status” indicates “Not Active”.

Results:

- **Result 1** – The ECM is reading the proper conditions for the activation of the “Idle Shutdown Timer”. Proceed to Test Step 2.
- **Result 2** – The ECM is not reading the proper conditions for activation of the “Idle Shutdown Timer”. Proceed to Test Step 3.

Test Step 2. Verify the Driver Alert Function for Idle Shutdown and the Override Function for Idle Shutdown.

A. Connect ET to the cab data link connector.

B. Access the Customer Parameters on ET.

a. Access the following display screens in order:

- “Service”
- “Configuration”

b. Record the programmed time for the “Idle Shutdown Time”. The “Idle Shutdown Time” must be between 3 and 1440 minutes. If the “Idle Shutdown Time” is programmed to 0, the timer is disabled.

c. Reprogram the “Idle Shutdown Time” to 3 minutes for this test.

C. Observe the following items during the 90 second period before the programmed shutdown time:

- Check engine lamp
- “Idle Shutdown Status”

D. If the customer parameter of “Allow Idle Shutdown Override” is programmed to “YES”, perform either of the following actions in order to override the shutdown:

- Press the clutch pedal.
- Press the service brake pedal.

Note: The pedals must be pressed while the check engine lamp is flashing. The check engine lamp flashes during the 90 second period before the programmed shutdown time.

E. Reprogram the “Idle Shutdown Time” to the value that was recorded earlier for this test.

Expected Result:

During the 90 second period before the scheduled shutdown, the status should change from “Counting” to “Driver Alert” and the check engine lamp should flash rapidly. If the “Allow Idle Shutdown Override” is programmed to “YES”, the “Idle Shutdown Status” should change to “Override” after the pedals are depressed.

Result 1 The idle shutdown timer behaves in the manner that is described above.

Result 2 The check engine lamp did not flash during the alert.

Result 3 The ECM did not sense a change in the status of the service brake.

Result 4 The ECM did not sense a change in the status of the clutch.

Results:

- **Result 1** – The idle shutdown timer is operating properly. **STOP.**
- **Result 2** – The check engine lamp did not flash during the alert.

Repair: Perform the following diagnostic procedure: Troubleshooting, “Check Engine Lamp Circuit - Test”

STOP.

- **Result 3** – The ECM did not sense a change in the status of the service brake.

Repair: Perform the following diagnostic procedure: Troubleshooting, “Service Brake Pedal Position (Switch 1) Circuit - Test”

STOP.

- **Result 4** – The ECM did not sense a change in the status of the clutch.

Repair: Perform the following diagnostic procedure: Troubleshooting, “Clutch Pedal Position Switch Circuit - Test”

STOP.

Test Step 3. Check the State of the Related Conditions When the Vehicle is Parked.

A. Check the state of the following related conditions when the vehicle is parked:

- Ensure that the vehicle speed is 0 km/h (0 mph) on ET or the dash display.
- Ensure that the engine is not in cold mode. (The ET status screen will indicate that "Cold Mode" is "Active" in the corner of the display screen.)
- Ensure that the PTO on/off switch is OFF.
- Ensure that the engine is at low idle.

Expected Result:

Result 1 Vehicle speed is not indicated as 0 km/h (0 mph).

Result 2 The ET status screen indicates that the engine is in cold mode.

Result 3 The status of the PTO on/off switch is not "OFF".

Result 4 The engine is not at low idle.

Results:

- **Result 1** – Vehicle speed is not indicated as 0 km/h (0 mph).

Repair: Perform the following diagnostic procedure: Troubleshooting, "Vehicle Speed Circuit - Test"

STOP.

- **Result 2** – The ET status screen indicates that the engine is in cold mode.

Repair: The engine must not be in "Cold Mode" operation while this test procedure is being performed. Allow the engine to run until the coolant temperature exceeds 20 °C (68 °F). Troubleshoot and repair any related conditions.

STOP.

- **Result 3** – The status of the PTO on/off switch is not "OFF".

Repair: Perform the following diagnostic procedure: Troubleshooting, "PTO Switch Circuit - Test"

STOP.

- **Result 4** – The engine is not at low idle.

Repair: Return the engine to Low Idle. Perform the test procedure again.

STOP.

i01632013

Ignition Key Switch Circuit and Battery Supply Circuit - Test

SMCS Code: 1408-081; 1553-081

System Operation Description:

Use this procedure under the following situation:

This procedure tests whether proper voltage is supplied by vehicle wiring. Use this procedure if any one of the following diagnostic codes are logged several times:

- 168-02 Intermittent Battery (51)
- 43-02 Ignition Key Switch Fault (71)

Also, use this procedure if you suspect that the ECM is not receiving the battery supply voltage.

Note: This code can be generated by rapidly cycling the ignition key switch. Some control modules on the vehicle require this action in order to prompt flash codes. If this occurs, clear the logged diagnostic codes in order to prevent future confusion or an incorrect diagnosis.

The following background information is related to this procedure:

The ECM receives electrical power (battery voltage) through the wiring that is supplied by the vehicle manufacturer. The ECM input at connector P1 terminal 70 (ignition key switch) receives battery voltage from the ignition key switch when the ignition key switch is in the ON position or the START position. When the ECM detects battery voltage at this input, the ECM will power up. When battery voltage is removed from this input, the ECM will power down.

The cause of an intermittent power supply to the ECM can occur on either the positive side (unswitched +battery) or the negative side (-battery). Both sides are routed from the ECM to the battery. The two unswitched +battery connections should be routed through a dedicated protection circuit.

Some vehicles may be equipped with an engine protection shutdown system or an idle timer shutdown system that interrupts electrical power to the ECM in order to shut down the engine. Also, some vehicles may be equipped with an engine protection shutdown system or an idle timer shutdown system that interrupts electrical power to the ignition key switch. The engine protection shutdown system can be an aftermarket device and the idle timer shutdown system can be external to the ECM. Some of these systems will not supply power to the ECM until one of the following conditions is met:

- The engine is cranked.
- The engine oil pressure achieves acceptable limits.
- An override button is pressed.

Keep in mind that these devices may be the cause of intermittent power to the ECM.

Usually, battery power to the cab data link connector is available and the battery power to the cab data link connector is independent of the ignition key switch. Therefore, you will be able to power up ET, but you may not be able to communicate with the engine ECM. The engine ECM requires the ignition key switch to be in the ON position in order to maintain communications. The ECM may power down a short time after connecting ET if the ignition key switch is in the OFF position. This is normal. Refer to Troubleshooting, "ATA (SAE J1587 / J1708) Data Link Circuit - Test".

For intermittent problems such as intermittent shutdowns that could be caused by vehicle wiring, temporarily bypassing the vehicle wiring may be an effective means of determining the root cause. If the symptoms disappear with the bypass wiring, the vehicle wiring is the cause of the problem. A means of bypassing vehicle wiring is explained in this test procedure. This is especially important for vehicles that do not provide dedicated circuits for the unswitched battery and the ignition key switch connections.

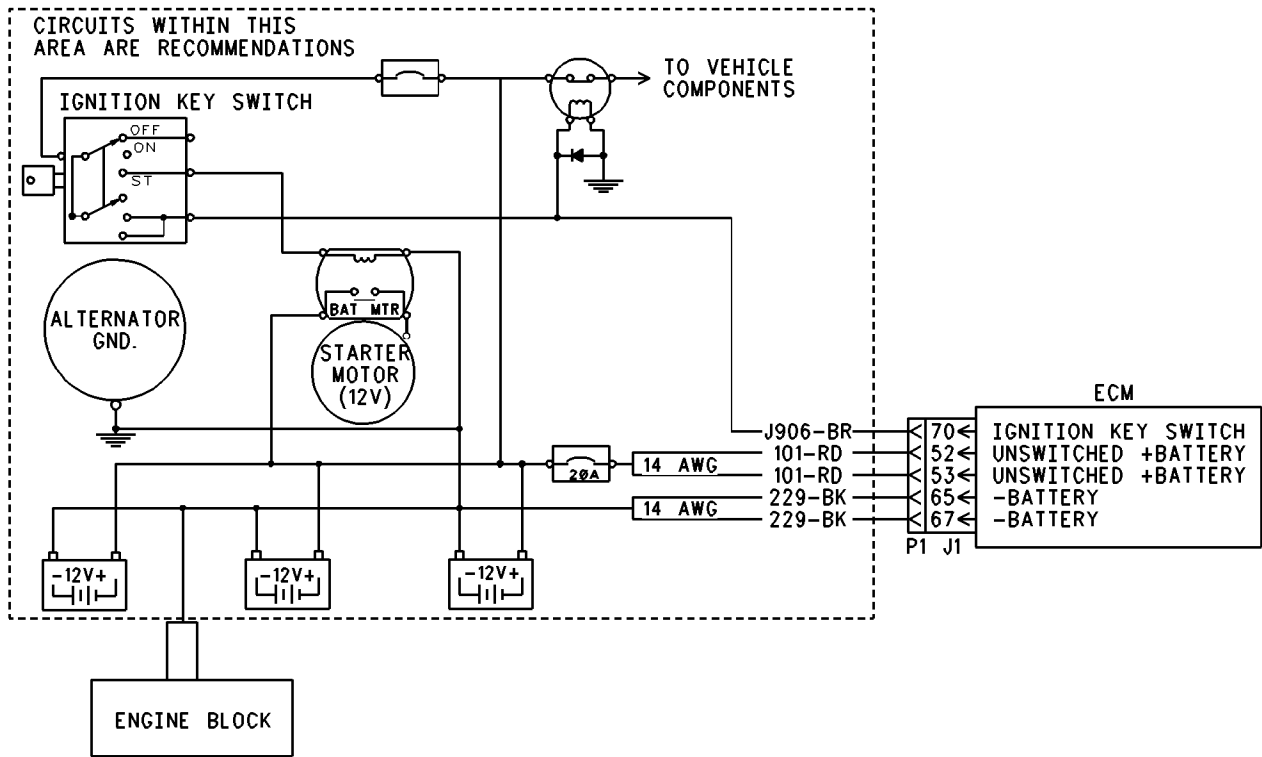

Illustration 118
Schematic for ECM battery circuit

g00742658

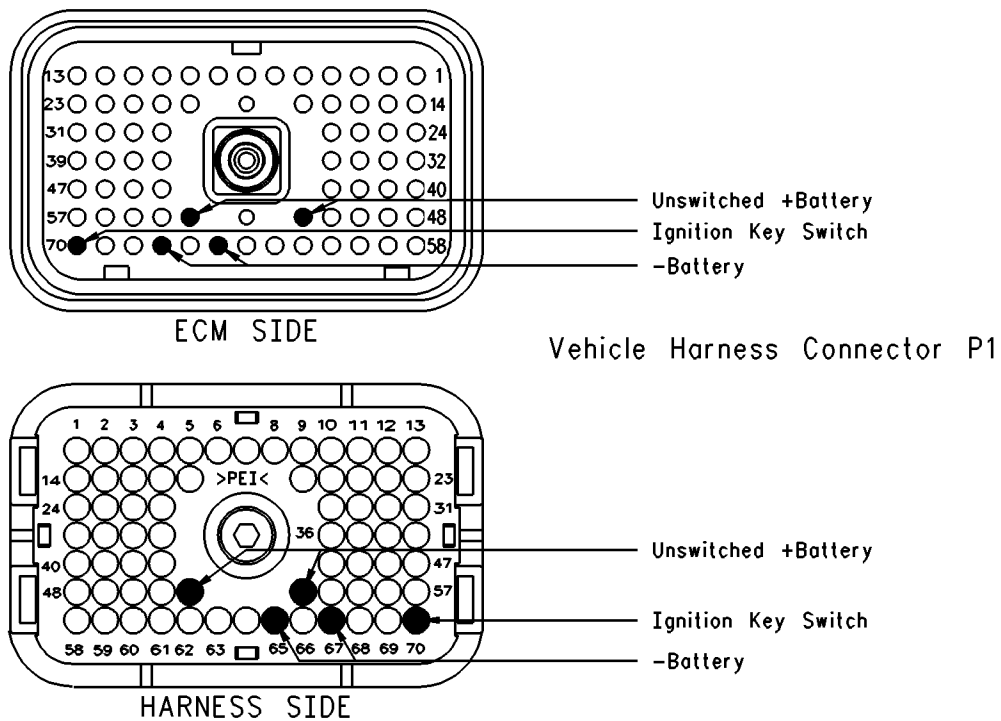

Illustration 119
Terminal locations for ECM

g00640974

Test Step 1. Inspect Electrical Connectors and Wiring.

- A.** Thoroughly inspect ECM vehicle harness connector J1/P1, the battery connections and the connections to the ignition key switch. Refer to Troubleshooting, “Electrical Connectors - Inspect” for details.
- B.** Perform a 45 N (10 lb) pull test on each of the wires in the ECM connector that are associated with the following connections:
- Unswitched +battery (terminals 52 and 53)
 - -Battery (terminals 65 and 67)
 - Ignition Key Switch (terminal 70)
- C.** Check the ECM connector (allen head screw) for the proper torque of 6.0 N·m (55 lb in).
- D.** Check the harness and wiring for abrasion and pinch points from the battery to the ECM, and from the ignition key switch to the ECM.

Expected Result:

All connectors, pins and sockets should be completely coupled and/or inserted and the harness and wiring should be free of corrosion, abrasion or pinch points.

Results:

- OK, Troubleshooting a 43-02 Code – Proceed to Test Step 2.
- OK, Troubleshooting a 168-02 Code – Proceed to Test Step 3.
- Not OK – There is a problem with the connectors or wiring.

Repair: Repair the connectors or wiring and/or replace the connectors or wiring. Ensure that all of the seals are properly in place and ensure that the connectors are completely coupled.

STOP.

Test Step 2. Use ET to Check the Ignition Key Switch.

- A.** Turn the ignition key switch to the OFF position.
- B.** Connect ET to the cab data link connector and access the status screen that shows the status of the ignition key switch.

- C.** Monitor the status of the ignition key switch while the ignition key switch is being cycled slowly from the ON position to the OFF position.

Note: ET may indicate that a new ECM has been detected. This condition is normal, due to a powerdown of the ECM with the ignition key switch in the OFF position.

Note: Cycling the ignition key switch several times may cause additional 43-02 faults to be logged. This is normal. Clear any logged faults.

Expected Result:

The status of the ignition key switch changes from “On” with the ignition key switch in the ON position to “Off” with the ignition key switch in the OFF position.

Results:

- YES – The input for the ignition key switch is functioning properly at this time.

Repair: If an intermittent connection is suspected, refer to Troubleshooting, “Electrical Connectors - Inspect”. Excessive cycling of the ignition key switch can cause this fault to be logged. This is normal. Clear any logged faults.

STOP.

- NO – Proceed to Test Step 3.

Test Step 3. Check the Battery Voltage at the ECM.

Perform Steps A, B, and C if the following diagnostic code is active or logged:

- 168-02 Intermittent Battery (51)

- A.** Disconnect vehicle harness connector P1 from ECM connector J1 and insert a breakout T.
- B.** Measure the voltage between vehicle harness connector P1 terminal 52 (unswitched +battery) and terminal 65 (-battery).

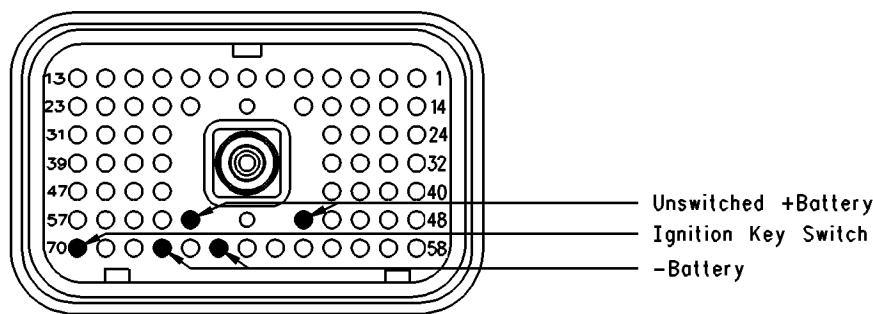

Illustration 120

g00640981

ECM Breakout T-connector

- C.** Measure the voltage from vehicle harness connector P1 terminal 53 (unswitched +battery) and terminal 67 (-battery).

Refer to Illustration 120 for the ECM breakout T-connector.

Perform Steps D, E, and F if the following diagnostic code is active or logged:

- 43-02 Ignition Key Switch Fault (71)
- D.** Disconnect vehicle harness connector P1 from ECM connector J1 and insert a breakout T.
- E.** Turn the ignition key switch to the ON position.
- F.** Measure the voltage between vehicle harness connector P1 terminal 70 (Ignition Key Switch) and terminal 65 (-battery).

Refer to Illustration 120 for the ECM breakout T-connector.

Expected Result:

For 12 Volt Systems, the measured voltage is a constant 11.0 to 13.5 VDC with no suspected intermittent problems at this time.

For 24 Volt Systems, the measured voltage is a constant 22.0 to 27.0 VDC with no suspected intermittent problems at this time.

Results:

- **OK** – The ECM is receiving the correct voltage.

Repair: If an intermittent condition is suspected, refer to Troubleshooting, “Electrical Connectors - Inspect”.

STOP.

- **Battery Voltage is out of range** – Proceed to Test Step 4.
- **Intermittent Or No Voltage** – Proceed to Test Step 5.
- **Key Switch Voltage Out Of Range**

Repair: Trace the wiring for the ignition key switch from the ECM through the key switch circuit to the batteries. Find the problem and repair the problem. Check the circuit protection for the circuit and the wiring. Refer to the vehicle service manual for instructions on troubleshooting the circuit for the ignition key switch.

Verify that the repairs eliminate the problem.

STOP.

Test Step 4. Check the Batteries.

- A.** Measure no-load battery voltage at the battery posts.
- B.** Load test the batteries. Use the **4C-4911** Battery Load Tester. Refer to Special Instruction, SEHS9249, “Use of 4C-4911 Battery Load Tester for 6, 8 and 12 Volt Lead Acid Batteries” and Special Instruction, SEHS7633, “Battery Test Procedure”.

Expected Result:

The batteries pass the load test. For 12 Volt Systems, the measured voltage is at least 11.0. For 24 Volt Systems, the measured voltage is at least 22.0.

Results:

- **YES**

Repair: Refer to the vehicle service manual for instructions on troubleshooting the vehicle wiring harness. Troubleshoot the vehicle wiring harness and repair the vehicle wiring harness, as required. Verify that the repairs eliminate the problem.

STOP.

- NO

Repair: Recharge or replace the faulty batteries. Verify that the repair eliminates the problem.

STOP.

Test Step 5. Use the Bypass Harness for ET to Bypass the Vehicle Wiring.

WARNING

Batteries give off flammable fumes which can explode.

To avoid injury or death, do not strike a match, cause a spark, or smoke in the vicinity of a battery.

NOTICE

Do Not connect the bypass harness to the battery until the 20 Amp in-line fuse has been removed from the +Battery line. If the fuse is not removed before connection to the battery, a spark may result.

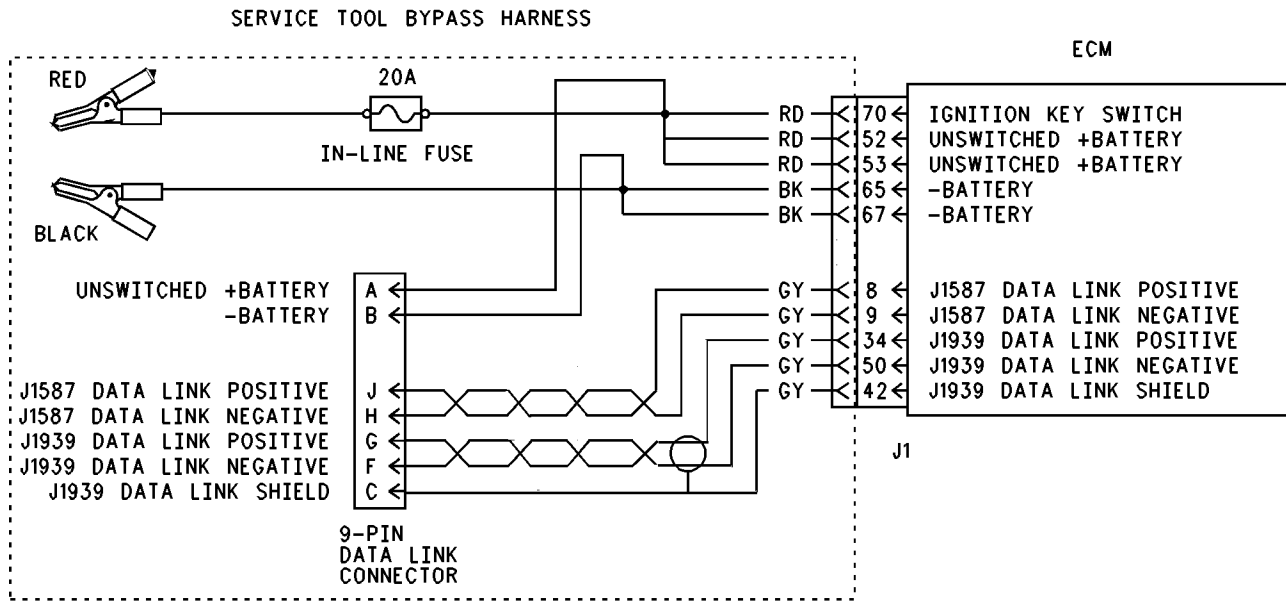

Illustration 121

g00741090

Bypass harness

Note: This bypass harness is only for test applications. This bypass harness may be left only temporarily on the vehicle. The bypass harness can be used in order to determine if the cause of the intermittent problem is interruptions in battery power to the ECM or the keyswitch circuit.

- A.** Turn the ignition key switch to the OFF position.
- B.** Disconnect vehicle harness connector J1/P1 from the ECM.
- C.** Connect a bypass harness to ECM connector J1.
- D.** Remove the 20 Amp in-line fuse from the +Battery line of the bypass harness and connect the unswitched +battery and – battery lines directly to the battery posts.

Note: This bypass directly connects the circuit for the ignition key switch to the ECM. The ECM will remain powered until the connection to the unswitched battery line “+” is disconnected. Remove the 20 Amp fuse from the in-line fuse holder to power down the ECM. Do Not connect the bypass to the battery posts without first removing the 20 Amp in-line fuse or do not remove the bypass from the battery posts without first removing the 20 Amp in-line fuse.

- E.** Connect ET to the data link connector of the bypass harness and verify that communication is established.
- F.** Restore all wiring to the original condition after testing.

Expected Result:

Installing the bypass eliminates the problem.

Note: The status of the ignition key switch will always indicate “On” while the bypass harness is installed.

Results:

- **Yes** – The symptoms disappear when the bypass harness is installed. Also, the symptoms return when the bypass harness is removed. The problem is in the vehicle wiring that supplies power to the ECM. Check for aftermarket engine protection switches that interrupt power. Send the vehicle to the OEM dealer to repair. **STOP.**

- **No**

Repair: Connect the bypass to another battery and verify if the problem is resolved. If the problem is resolved, the problem is with the vehicle batteries.

If the problem still exists, temporarily connect a test ECM. Remove all jumpers and replace all connectors. Recheck the system for active diagnostic codes and repeat the test step. If the problem is resolved with the test ECM, reconnect the suspect ECM. If the problem returns with the suspect ECM, replace the ECM.

Verify that the repair eliminates the problem.

STOP.

Note: The wiring for your particular application may be slightly different. The circuits for the sensor common are used interchangeably by the OEM of the vehicle. The following circuits are common within the ECM:

- The “Input Sensor Common 1” is terminal 18.
- The “Input Sensor Common 2” is terminal 3.
- The “AP Sensor/Switch Sensor Common” is terminal 5.

i01608362

Ignore Brake/Clutch Switch Circuit - Test

SMCS Code: 1900-081-ZS

System Operation Description:

Use this procedure under the following situation:

Use this procedure to determine if the circuit for the Ignore Brake/Clutch Switch is operating correctly.

Note: This feature is available with MAR98 and newer software. This feature is also available with OCT01 and newer software. The parameter “Input # 5” has been replaced with the parameter “Ignore Brake/Clutch Switch”. To use this feature, the “Ignore Brake/Clutch Switch” parameter must be programmed to “J1/P1:47”.

The following background information is related to this procedure:

The ECM can use various inputs in a number of ways. The inputs depend on the parameter programming. Certain features are available on several different inputs. The configuration for the switch must match the actual switch installation in order for the switch to function properly.

Ignore Brake/Clutch Switch

The ignore brake/clutch switch is typically used with a “Cab Switches PTO Configuration” which requires mobile use of the vehicle during PTO operation. When the ignore brake/clutch switch is ON, depressing the brake or the clutch will NOT disengage PTO operation or a set engine speed. If the “Input # 5” parameter is programmed to “None” (default), this feature is not used. If the “Input # 5” parameter is programmed to “Ignore Brake/Clutch”, then the feature is available and the switch circuit should be connected to terminal 47 of the J1/P1 ECM vehicle harness connector.

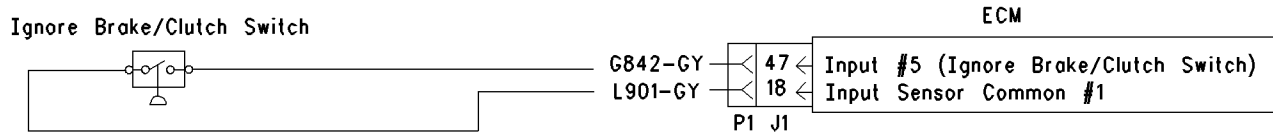

Illustration 122

g00682286

Schematic for ignore brake/clutch switch

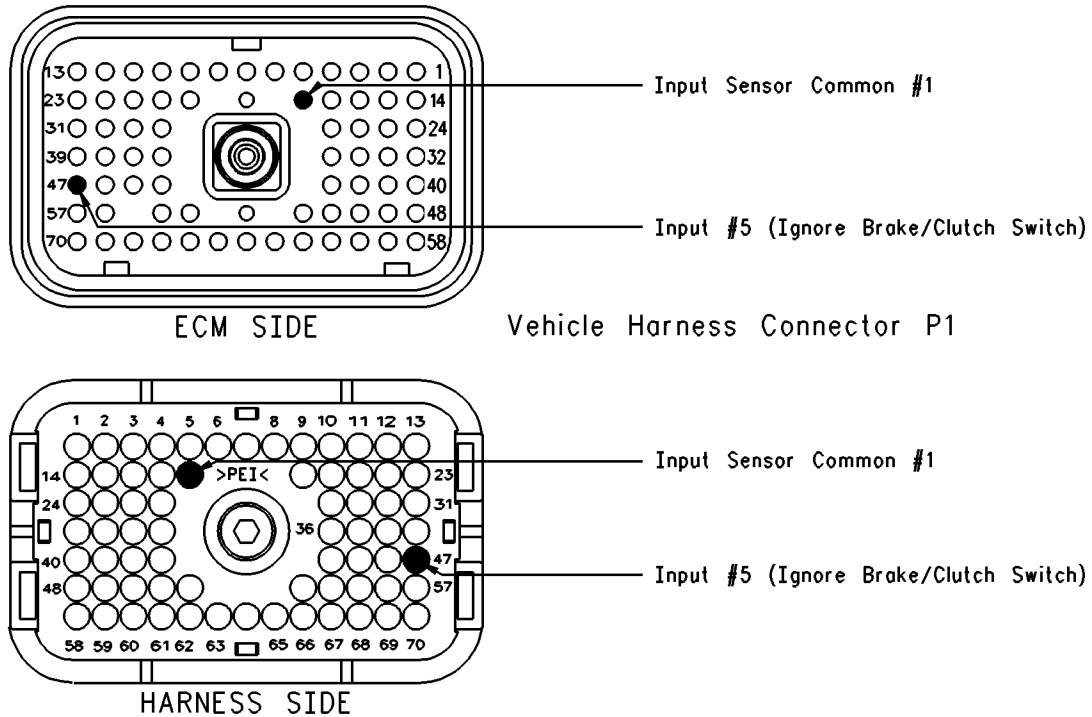

Illustration 123

g00682292

Terminal Locations for ECM

Test Step 1. Inspect Electrical Connectors and Wiring

- A. Thoroughly inspect the ECM vehicle harness connector J1/P1, the connectors, and the firewall bulkhead connectors. Refer to Troubleshooting, "Electrical Connectors - Inspect" for details.
- B. Perform a 45 N (10 lb) pull test on each of the wires in the ECM connector that are associated with the circuit for the Ignore Brake/Clutch Switch.
- C. Check the ECM connector (allen head screw) for the proper torque of 6.0 N·m (55 lb in).
- D. Check the harness and the wiring for abrasion and pinch points from the ignore brake/clutch switch to the ECM.

Refer to Illustration 123 for terminal locations for the ECM.

Expected Result:

All connectors, pins, and sockets are completely coupled and/or inserted, and the harness and wiring should be free of corrosion, abrasion or pinch points.

Results:

- OK – Proceed to Test Step 2.
- Not OK – Repair the wiring and connectors or replace the wiring or the connectors. Ensure that all of the seals are properly connected. Verify that the repair eliminates the problem. STOP.

Test Step 2. Check the Status of the Ignore Brake/Clutch Switch on ET.

- A. Connect ET at the cab data link connector.
- B. Turn the ignition key switch to the ON position.

C. Operate the switch in the ON and OFF positions.

D. View the status for parameter "Input # 5" on ET.

Note: For "OCT01" software, view the status for "Ignore Brake/Clutch Switch".

E. If the status for parameter "Input # 5" indicates "None", then the "Input # 5" parameter has not been programmed.

Expected Result:

The status screen should indicate "On" if the switch is turned ON. The status screen should indicate "Off" if the switch is turned OFF.

Results:

- **Yes** – The switch is operating normally. Continue troubleshooting if the original condition is not resolved. **STOP.**
- **No** – The ECM is not reading the change in switch status. Proceed to Test Step 3.

Test Step 3. Check the Switch Circuit at the ECM.

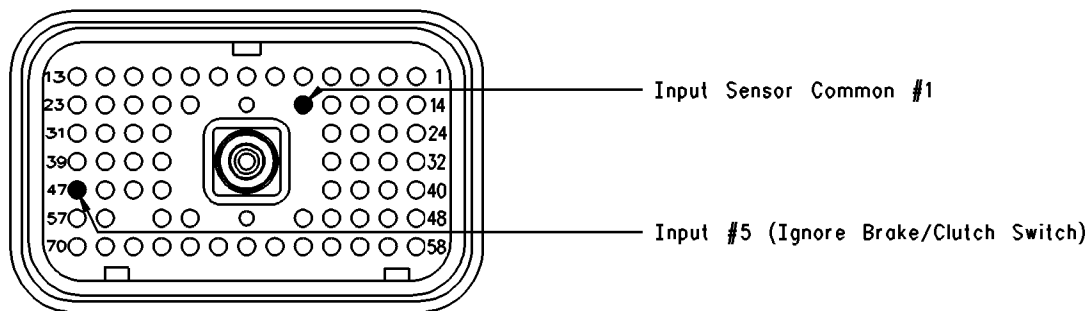

Illustration 124
Connector for breakout T

g00682301

A. Turn the ignition key switch to the OFF position.

B. Install a breakout T to the ECM vehicle harness connector J1/P1.

C. Fabricate a jumper wire 100 mm (4 inch) long. Crimp a Deutsch pin to both ends of the wire.

D. Insert the jumper wire into terminal 18 (Input Sensor Common #1) of the breakout T. Insert the other end of the jumper wire into terminal 47 (Ignore Brake/Clutch Switch) of the breakout T.

E. Connect ET at the cab data link connector.

F. Turn the ignition key switch to the ON position.

G. Alternately remove the jumper wire and insert the jumper wire at terminal 18 while you monitor the status screen on ET.

Expected Result:

The switch status changes from On with the jumper wire in place to Off when the jumper wire is removed.

Results:

- **Yes** – The ECM is functioning properly at this time. Proceed to Test Step 4.
- **No** – The ECM is not functioning properly.

Repair: Perform the following repair:

1. Temporarily connect a test ECM.
2. Remove all jumpers and replace all connectors.
3. Recheck the system for active diagnostic codes.
4. Repeat the test step.
5. If the problem is resolved with the test ECM, reconnect the suspect ECM.
6. If the problem returns with the suspect ECM, replace the ECM.
7. Verify that the repair eliminates the problem.

STOP.

Test Step 4. Insert a Jumper Wire at the Switch.

- A. Turn the ignition key switch to the OFF position.
- B. Reconnect the ECM vehicle harness connector J1/P1.
- C. Fabricate a jumper wire 100 mm (4 inch) long. Crimp a Deutsch pin to both ends of the wire.
- D. Insert the jumper wire between the two terminals of the ignore brake/clutch switch.
- E. Turn the ignition key switch to the ON position.
- F. Alternately remove the jumper wire and then insert the jumper wire at the switch terminals. At the same time, watch the status screen on ET.

Expected Result:

The switch status changes to On with the jumper wire in place to “Off” when the jumper wire is removed.

Results:

- **Yes**

Repair: Replace the ignore brake/clutch switch.

Verify that the repair eliminates the problem.

STOP.

- **No** – There is a problem in the wire harness between the Ignore Brake/Clutch Switch and the ECM. Proceed to Test Step 5.

Test Step 5. Insert a Jumper Wire at the Bulkhead Connector.

- A. Turn the ignition key switch to the OFF position.
- B. Fabricate a jumper wire 100 mm (4 inch) long. Crimp a Deutsch pin to both ends of the wire.
- C. Insert the jumper wire between the two terminals for the ignore brake/clutch switch on the engine side of the ECM bulkhead connector.
- D. Turn the ignition key switch to the ON position.
- E. Alternately connect and then disconnect the jumper wire. At the same time, monitor the status screen on ET.

Expected Result:

The switch status changes from On with the jumper wire in place to “Off” when the jumper wire is removed.

Results:

- **Yes** – The problem is in the vehicle wiring between the bulkhead connector and the switch.

Repair: Inspect the vehicle wiring and then repair the vehicle wiring. Otherwise, send the vehicle to the OEM dealer for repair.

Verify that the original condition is resolved.

STOP.

- **No** – The problem is in the vehicle wiring between the bulkhead connector and the ECM.

Repair: Inspect the vehicle wiring and then repair the vehicle wiring. Otherwise, send the vehicle to the OEM dealer for repair.

Verify that the original condition is resolved.

STOP.

i01856391

Injection Actuation Pressure - Test

SMCS Code: 1714-081

System Operation Description:

Use the steps that follow to check the operation of the HEUI fuel system. Circle the appropriate answer in the **Results** section of each step. Complete the pages. Return the pages with any of the requested parts through the part return system.

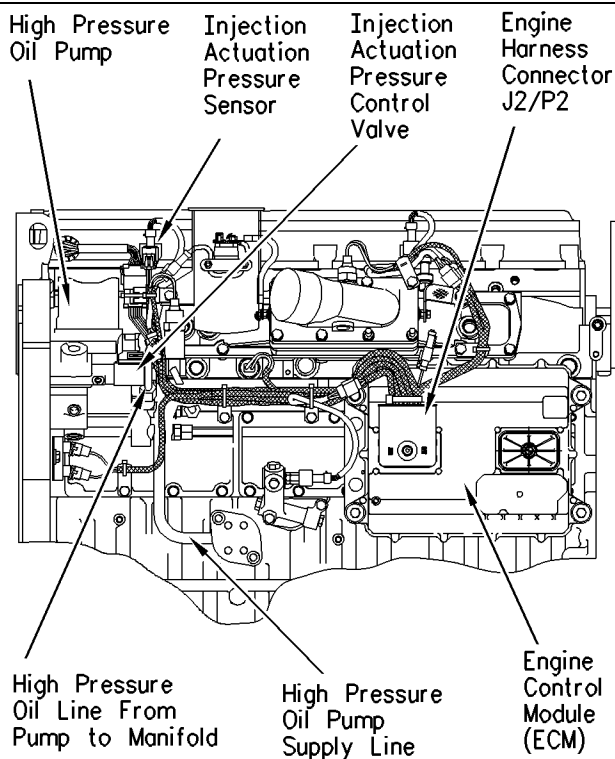

Illustration 125

g00725749

HEUI fuel system components (typical example)

Test Step 1. Symptoms

The following symptoms may occur if there is a problem with the HEUI fuel system:

- The engine cranks but the engine will not start.
- The engine runs rough.
- The engine is erratic or unstable at idle or running.
- Low power

- The following fault codes might be currently active codes or logged event codes: 164-00, 164-02, and 164-11.

Complete the following test steps. Circle the appropriate answers in the **Results** section of each test step and return with the fuel system component.

- A. Connect the electronic service tool to the service tool connector.
- B. Turn the ignition keyswitch to the ON position but **do not start the engine**.
- C. Print the "Lifetime Totals" and the "Configuration" screen.
- D. Check for active diagnostic codes.

Expected Result:

There are no active diagnostic codes with the keyswitch in the ON position and the engine off.

Results:

- **OK** – There are no active codes. Proceed to Test Step 2.
- **Not OK** – Active codes are present with the keyswitch in the ON position and the engine off.

Repair: Refer to Troubleshooting, "Injection Actuation Pressure Sensor - Test" if 164-03 or 164-04 is active.

Call technical support if 164-00, 164-02, or 164-11 is active.

STOP.

Test Step 2. Check the Engine Oil Level

- A. Check the engine oil level.
- B. If the engine oil level is low add oil to the engine.
- C. Try to start the engine.

Expected Result:

The engine starts.

Results:

- **Yes** – The engine starts. Proceed to Test Step 9.
- **No** – The engine does not start. Proceed to Test Step 3.

Test Step 3. Engine Cranks but Will not Start

Your answers indicated that your engine oil level is satisfactory. Do not replace the Injection Actuation Pressure Sensor (IAP Sensor) at this time.

- A. Connect the electronic service tool to the engine. Observe the "Injection Actuation Pressure" and "Engine RPM" when the engine is cranking.

_____ Record the actual Injection Actuation Pressure.

_____ Record the observed engine speed.

Expected Result:

The injection actuation pressure is above 6 MPa (870 psi).

Results:

- **Yes** – The injection actuation pressure is above 6 MPa (870 psi).

Repair: The HEUI system is functioning correctly. Refer to Troubleshooting , "Engine Cranks but Will Not Start" which is located in the "Troubleshooting without a Diagnostic Code" section.

STOP.

- **No** – The injection actuation pressure is below 6 MPa (870 psi). Proceed to Test Step 4.

Test Step 4. Check the Oil Pressure

Disconnect the high pressure oil line from the cylinder head and install the 8T-0852 Pressure Gauge. Crank the engine and record the oil pressure.

Note: The pressure readings may vary between gauges.

_____ Observed pressure reading

_____ Observed RPM

_____ Observed "Injection Actuation Output Percent"

Expected Result:

The oil pressure is above 27.5 MPa (4000 psi).

Results:

- **Yes** – The oil pressure is above 27.5 MPa (4000 psi). Proceed to Test Step 8.

- **No** – The oil pressure is below 27.5 MPa (4000 psi). Proceed to Test Step 5.

Test Step 5. Install a Test Plug and Check the Oil Pressure

- A. Remove the Injection Actuation Pressure Control Valve (IAPCV).

- B. Install a 219-2368 Plug and 9X-1484 Seal Kit and perform the pressure test.

_____ Observed pressure reading

Note: If the 219-2368 Plug is not available, proceed to Test Step 6.

Expected Result:

The oil pressure is above 27.5 MPa (4000 psi).

Results:

- **Yes** – The oil pressure is above 27.5 MPa (4000 psi). The HEUI pump is OK.

Repair: Replace the IAPCV and check the oil pressure. If the problem continues contact technical support.

STOP.

- **No** – The oil pressure is below 27.5 MPa (4000 psi). Proceed to Test Step 7.

Test Step 6. Install a New IAPCV and Check the Oil Pressure

Note: Use this Test Step ONLY if the 219-2368 Plug is not available.

- A. Remove the IAPCV.

- B. Install a new IAPCV and check the oil pressure.

_____ Observed pressure reading

Expected Result:

The oil pressure is above 27.5 MPa (4000 psi).

Results:

- **Yes** – The problem has been resolved. STOP.
- **No** – Remove the new IAPCV and reinstall the original IAPCV. Proceed to Test Step 7.

Test Step 7. Check the Drive Gear

- A. Remove the high pressure oil pump.

- B.** Check for any physical damage to the drive gear. Replace the drive gear, if necessary.
- C.** Verify that the drive gear and the retaining bolt are properly tightened. Also verify that the pump shaft rotates freely.

Expected Result:

The drive gear and the retaining bolt for the high pressure oil pump are tight. The pump shaft rotates freely.

Results:

- **Yes** – The drive gear bolt is properly tightened and the pump shaft rotates freely.

Repair: Replace the high pressure oil pump. If this does not fix the problem, contact technical support.

STOP.

- **No** – The pump shaft does not rotate freely.

Repair: Replace the high pressure oil pump. If this does not fix the problem, contact technical support.

STOP.

- **No** – The drive gear bolt is loose. The pump shaft rotates freely and there is no obvious mechanical damage that would indicate a different failure.

Repair: Tighten the drive gear bolt to a torque of 110 ± 14 N·m (80 ± 10 lb ft). Check the pressure in order to ensure that the problem has been resolved. If this does not fix the problem, replace the high pressure oil pump.

STOP.

Test Step 8. Check the High Pressure Oil System for Leaks.



Hot oil and components can cause personal injury.

Do not allow hot oil or components to contact skin.

- A.** Remove the valve cover and inspect the high pressure oil system for oil leaks.

- B.** While the engine is being cranked, look around the injector bores for any signs of oil leakage. Inspect the injector spill ports for excessive oil. All six injectors should spill the same amount of oil.

Expected Result:

No leaks are apparent.

Results:

- **OK** – Call technical support for assistance. **STOP.**
- **Not OK**

Repair: Replace the O-ring on the injector or replace the damaged injector.

STOP.

Test Step 9. Engine Starts

- A.** Connect the electronic service tool to the engine and start the engine.

- B.** Check for the following codes:

- 164-00 Injection Actuation Pr Out of Range
- 164-02 Injection Actuation Pr Sensor Erratic
- 164-11 Injection Actuation Pressure System

Expected Result:

164-00 or 164-11 is active or logged.

Place a check beside the codes that are active or logged.

- _____ 164-00
- _____ 164-02
- _____ 164-11

Results:

- **Yes** – 164-00 or 164-11 is active or logged. 164-02 may also be active or logged. Proceed to Test Step 10.
- **No** – 164-02 is active or logged, but 164-00 and 164-11 are not active or logged.

Repair: Refer to Troubleshooting, "Injection Actuation Pressure Sensor - Test" for information on troubleshooting the active 164-02 code.

STOP.

Test Step 10. Evaluate the Quality of the Oil

Extended oil drain intervals may cause elevated levels of soot in the engine oil. The elevated levels of soot may also deplete the additive package of the oil. This can affect the operation of the HEUI high pressure oil system.

Use the following formulas to calculate the correct oil change intervals. Scheduled oil sampling should be used to provide the most accurate oil change interval.

The formulas require information to be collected from the electronic service tool. Enter the values from the electronic service tool for "Total Distance" and "Total Fuel".

English

Total Distance _____ (miles)
 / Total Fuel _____ (gallons)
 = Overall MPG _____
 Overall MPG _____
 X 50
 X Oil Pan Capacity in Quarts _____
 = Recommended Interval _____

Metric

Total Distance _____ (kilometers)
 / Total Fuel _____ (liter)
 = Overall KPL _____
 Overall KPL _____
 X 200
 X Oil Pan Capacity in Liters _____
 = Recommended Interval _____

Note: The recommended capacities for oil pans that follow are for truck engines.

- The capacity for the shallow oil pan is 21 L (22 qt).
- The capacity for the deep oil pan is 28 L (30 qt).

Record the drain interval that the owner is currently using.

_____ Drain interval

_____ Miles or Kilometers since the last oil change.

Expected Result:

The customer has not exceeded the suggested oil change interval and an oil change does not need to be performed.

Results:

- **Yes** – Proceed to Test Step 11.

- **No** – Before you proceed, ask the customer to authorize an oil change with a new oil filter. Oil changes are not covered by the warranty. After the engine oil and the oil filter have been changed, operate the engine until normal operating temperature has been reached. Run the engine up and down through the operating rpm range for 10 to 15 minutes. This will purge any trapped air or debris that is in the system. If the problem still exists or if the problem reoccurs in a short period of time, proceed to Test Step 11.

Test Step 11. Check the System with the "Injection Actuation Pressure Test"

- Install 8T-0852 Pressure Gauge on the high pressure oil rail.
- Connect the electronic service tool to the service tool connector.
- Access the "Injection Actuation Pressure Test" in the "Diagnostics Menu" of the electronic service tool and begin the test.

Note: The "Injection Actuation Pressure Test" can increase the injection actuation pressure or the "Injection Actuation Pressure Test" can decrease the injection actuation pressure. The test adjusts the oil pressure in steps. Depending on the interface which you are using, you may have either three steps or four steps.

Table 170

Step	Manual Pressure gauge	Electronic Service Tool	Difference
1			
2			
3			
4			

Expected Result:

The pressure that is measured with the pressure gauge for each step and the pressure that is displayed on the electronic service tool for each step are within 1379 kPa (200 psi).

Results:

- **Yes** – The injection actuation pressure sensor is operating properly. Proceed to Test Step 12.
- **No** – The injection actuation pressure sensor may be faulty. Replace the sensor and repeat this test step. If the problem still exists, verify the accuracy of the pressure gauge. Reinstall the original sensor and proceed to Test Step 12.

Test Step 12. Perform the “Injection Actuation Pressure Test” at both Low Idle and at High Idle

Start the engine. Run the “Injection Actuation Pressure Test” at low idle and at high idle.

Record the data in the following table.

Table 171

Low Idle		
Step	Actual injection pressure from the electronic service tool	“Injection Pressure Percentage Output” from the electronic service tool
1		
2		
3		
4		
High Idle		
Step	Actual injection pressure from the electronic service tool	“Injection Pressure Percentage Output” from the electronic service tool
1		
2		
3		
4		

Expected Result:

The “Injection Actuation Pressure Output” never exceeds 65% and never falls to 0 %.

Results:

- Yes – Call technical support for assistance. STOP.
- No – Proceed to Test Step 13.

Test Step 13. Install a New IAPCV and Repeat the “Injection Actuation Pressure Test”

Replace the IAPCV and perform the “Injection Actuation Pressure Test”.

Record the data in the following table.

Table 172

Low Idle		
Step	Actual injection pressure from the electronic service tool	“Injection Pressure Percentage Output” from the electronic service tool
1		
2		
3		
4		
High Idle		
Step	Actual injection pressure from the electronic service tool	“Injection Pressure Percentage Output” from the electronic service tool
1		
2		
3		
4		

Expected Result:

The “Injection Actuation Pressure Output” never exceeds 65% and never falls to 0 %.

Results:

- Yes – Verify that the problem is solved. STOP.
- No – Reinstall the original IAPCV. Proceed to Test Step 14.

Test Step 14. Check the Oil Pressure

- Turn the engine off.
- Remove the Injection Actuation Pressure Control Valve (IAPCV).
- Install a 219-2368 Plug and 9X-1484 Seal Kit and perform the pressure test.
- Disconnect the high pressure oil line from the cylinder head and install the 8T-0852 Pressure Gauge. Crank the engine and record the oil pressure.

Note: The pressure readings may vary between gauges.

_____ Observed pressure reading

_____ Observed RPM

Expected Result:

The oil pressure is above 27.5 MPa (4000 psi).

Results:

- **Yes** – The high pressure oil pump is working properly. Proceed to Test Step 16.
- **No** – The high pressure oil pump may be faulty. Proceed to Test Step 15.

Test Step 15. Check the Drive Gear

- Remove the high pressure oil pump.
- Check for any physical damage to the drive gear. Replace the drive gear, if necessary.
- Verify that the drive gear and the retaining bolt are properly tightened. Also verify that the pump shaft rotates freely.

Expected Result:

The drive gear and the retaining bolt for the high pressure oil pump are tight. The pump shaft rotates freely.

Results:

- **Yes** – The drive gear bolt is properly tightened and the pump shaft rotates freely.

Repair: Replace the high pressure oil pump. If this does not fix the problem, contact technical support.

STOP.

- **No** – The pump shaft does not rotate freely.

Repair: Replace the high pressure oil pump. If this does not fix the problem, contact technical support.

STOP.

- **No** – The drive gear bolt is loose. The pump shaft rotates freely and there is no obvious mechanical damage that would indicate a different failure.

Repair: Tighten the drive gear bolt to a torque of 110 ± 14 N·m (80 ± 10 lb ft). Check the pressure in order to ensure that the problem has been resolved. If this does not fix the problem, replace the high pressure oil pump.

STOP.

Test Step 16. Check the High Pressure Oil System for Leaks**WARNING**

Hot oil and components can cause personal injury.

Do not allow hot oil or components to contact skin.

- Remove the valve cover and inspect the high pressure oil system for oil leaks.
- While the engine is being cranked, look around the injector bores for any signs of oil leakage. Inspect the injector spill ports for excessive oil. All six injectors should spill the same amount of oil.

Expected Result:

No leaks are apparent.

Results:

- **OK** – Call technical support for assistance. **STOP.**
- **Not OK**

Repair: Replace the O-ring on the injector or replace the damaged injector.

STOP.

i01856379

Injection Actuation Pressure Control Valve Circuit - Test

SMCS Code: 5051-081

System Operation Description:**Use this procedure under the following situation:**

Use the following information in order to troubleshoot the system when there is an active code:

- 42-11 Injection Actuation Pressure Control Valve Driver (18)

Note: Do not use this procedure for an active diagnostic code of 164-11 Injection Actuation Pressure System unless you are directed to this procedure from the "Injection Actuation Pressure - Test". If the diagnostic code of 164-11 Injection Actuation Pressure System is active, refer to Troubleshooting, "Injection Actuation Pressure - Test".

The following background information is related to the following procedure:

The injection actuation pressure control valve regulates the high pressure oil to the injectors through a high pressure rail. The high pressure oil manifold is used to actuate the injectors and the high pressure oil manifold is used to control the fuel injection pressure. The injection actuation pressure control valve relieves excess high pressure oil back to the sump. The ECM controls the operation of the injection actuation pressure control valve by monitoring the engine rpm and the injection actuation pressure sensor.

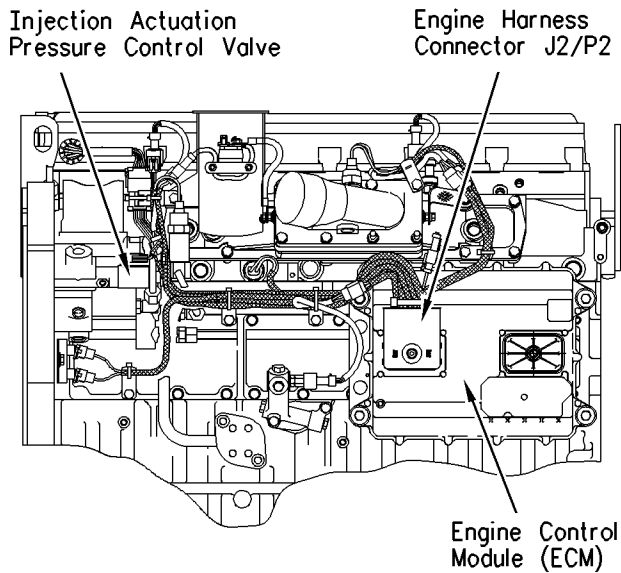

Illustration 126 g00724789
 Location of the injection actuation pressure control valve

INJECTION ACTUATION PRESSURE CONTROL VALVE

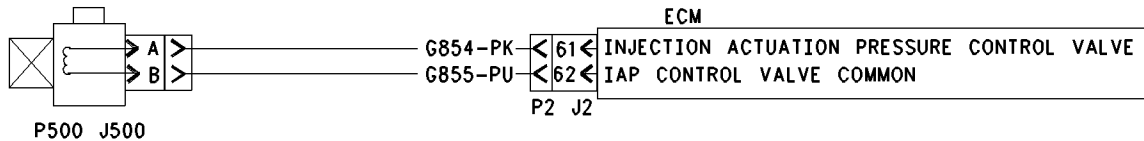

Illustration 127 g00724834
 Schematic for the injection actuation pressure control valve

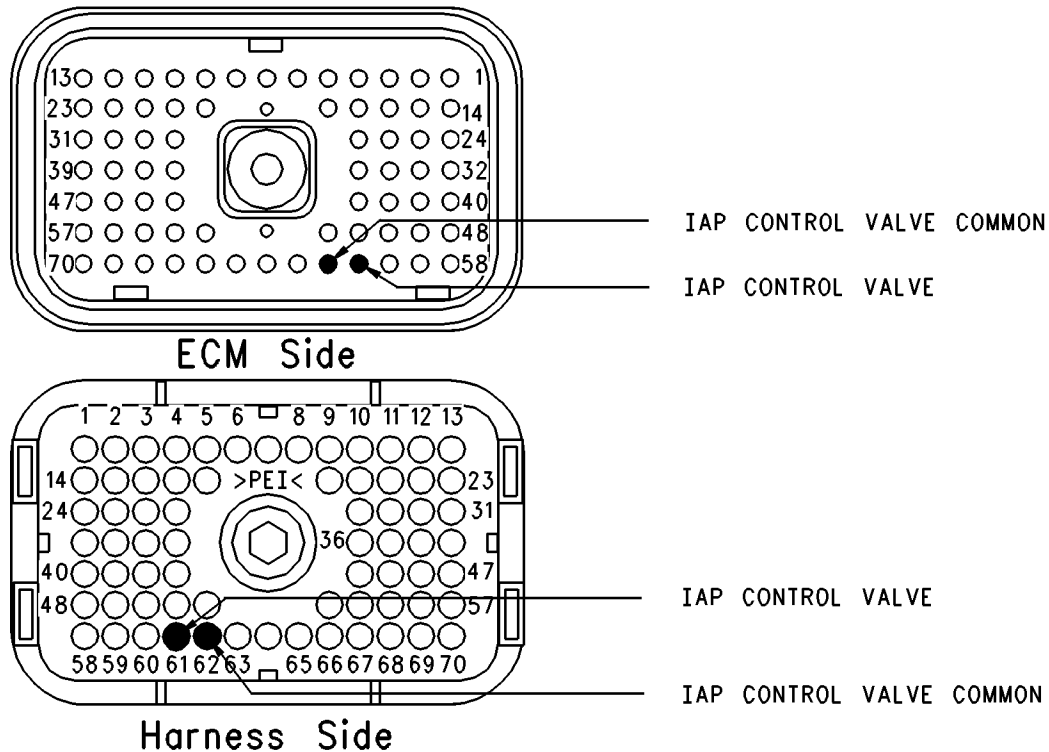

Illustration 128

g00724865

Locations for the ECM terminals

Test Step 1. Use the Electronic service Tool to Check for Active Diagnostic Codes.

- A. Connect the electronic service tool to the cab data link connector.
- B. Start the Engine.
- C. Monitor the “Active Diagnostic Code” screen on the electronic service tool. Check and record active diagnostic codes.

Note: Wait at least 15 seconds in order for the diagnostic codes to become active.

Expected Result:

42-11 Injection Actuation Pressure Valve Driver is active.

Results:

- Yes – Proceed to Test Step 2.
- No –

Repair: Refer to Troubleshooting, “Troubleshooting Without a Diagnostic Code”.

STOP.

Test Step 2. Inspect Electrical Connectors and Wiring.

- A. Thoroughly inspect the connector J500/P500 for the injection actuation pressure control valve and inspect the ECM engine harness connector J2/P2. Refer to Troubleshooting, “Electrical Connectors - Inspect” for details.
- B. Perform a 45 N (10 lb) pull test on each of the wires in the ECM connector that are associated with the injection actuation pressure sensor (terminals 61 and terminal 62).
- C. Check the ECM connector (allen head screw) for the proper torque of 6.0 N·m (55 lb in).
- D. Check the harness and wiring for abrasion and pinch points from the sensors back to the ECM.

Expected Result:

All connectors, pins and sockets should be completely coupled and/or inserted and the harness and wiring should be free of corrosion, abrasion or pinch points.

Results:

- OK – Proceed to Test Step 3.
- Not OK

Repair: Perform the following repair:

Repair the connectors or wiring and/or replace the connectors or wiring. Ensure that all of the seals are properly in place and ensure that the connectors are completely coupled.

Verify that the repair eliminates the problem.

STOP.

Test Step 3. Measure the Solenoid Resistance of the Injection Actuation Pressure Control Valve.

A. Turn the ignition key switch to the OFF position.

B. Disconnect the connector for the injection actuation pressure control valve J500/P500.

Note: Ensure that the seal on the connector P500 remains on P500 when the connector is disconnected.

C. Use a multimeter to measure the resistance between the two terminals of the section of the harness for the injection actuation pressure control valve. Record the value that was measured.

D. Reverse the leads of the multimeter and measure the resistance again.

Expected Result:

The solenoid resistance of the injection actuation pressure control valve should be between 4.0 and 16.0 Ohms.

Results:

- **Yes** – Record the measured resistance. Reconnect the harness connector for the injection actuation pressure control valve. Proceed to Test Step 4.
- **No**

Repair: Replace the injection actuation pressure control valve. Start the engine and verify that the fault is no longer active.

STOP.

Test Step 4. Measure the Solenoid Resistance through the Engine Harness.

A. Turn the ignition key switch to the OFF position.

B. Disconnect the ECM engine harness connector J2/P2.

C. Check the electrical resistance from the ECM engine harness connector P2 terminal 61 to P2 terminal 62. The resistance should be within 2 ohms of the previous test results.

D. Check the electrical resistance from the ECM engine harness connector P2 terminal 62 to the surrounding terminals for a short circuit:

- Terminal 51
- Terminal 52
- Terminal 63

E. Check the resistance from the ECM engine harness connector P2 terminal 61 to the surrounding terminals for a short circuit:

- Terminal 50
- Terminal 51
- Terminal 52
- Terminal 60

Note: The resistance should be greater than 10k ohms.

F. Check the resistance from the ECM engine harness connector P2 terminal 61 to the engine ground stud and from P2 terminal 62 to the engine ground stud. The resistance should be greater than 10k ohms.

Expected Result:

The resistance measurements are within the proper range.

Results:

- **Yes** – Proceed to Test Step 5.
- **No**

Repair: Replace the harness for the injection actuation pressure control valve.

STOP.

Test Step 5. Use the “Injection Actuation Pressure Driver Test” on the Electronic Service Tool to Check the Harness.

A. Connect the electronic service tool to the cab data link connector.

B. Turn the ignition key switch to the ON position.

C. Access the “Injection Act Press Driver Test”.

D. Disconnect the injection actuation pressure control valve from the engine harness.

Note: Do not insert any wire that is larger than 18 AWG into the harness connector (P500). Do not insert the probe for the voltage test lamp into the harness connector (P500). These actions will spread the sockets of the connector which will damage the connector. Damaged connectors could cause intermittent connections.

E. Insert a **9X-7200** ECM Pin Terminal into each of the harness connector sockets P500 for the injection actuation pressure driver.

F. Connect a voltage test lamp to the ECM pin terminals that are inserted in the P500 connector and start the “Injection Act Press Driver Test” with the electronic service tool. Then stop the “Injection Act Press Driver Test” with the electronic service tool.

Note: This test procedure may cause a 42-11 Injection Actuation Pressure Control Valve Driver (18). This is normal.

Expected Result:

The voltage test lamp should come on when the test is active.

Note: Personality Modules with a manufactured date before JUNE 99 require an electrical connector for the injection actuation pressure sensor to be disconnected in order for the “Injection Actuation Pressure Control Valve Driver Special Test” to turn off the driver for the injection actuation pressure control valve. If the connector J204/P204 for the injection actuation pressure sensor is not disconnected, the voltage test lamp will remain on when the special test is not active.

Results:

- **Yes** – Proceed to Test Step 6.
- **No** – Proceed to Test Step 7.

Test Step 6. Perform “Injection Actuation Pressure Test”.

A. Disconnect the injection actuation pressure control valve from the engine harness at connector J500/P500.

B. Crank the engine for 30 seconds. Crank the engine three times. This will purge the air from the system.

C. Connect the injection actuation pressure control valve to the engine harness at connector J500/P500.

D. Start the engine and run the “Injection Actuation Pressure Test”. The “Injection Actuation Pressure Test” is located in the “Diagnostics” menu of the electronic service tool. Step through all of the pressure ranges.

Note: This is not the “Injection Act Press Driver Test”.

E. After performing the “Injection Actuation Pressure Test”, check for active diagnostic codes or logged diagnostic codes 42-11.

Expected Result:

The engine should start and the engine should run without triggering any diagnostic codes.

Results:

- **Yes** – The problem has been corrected. **STOP.**
- **No**

Repair: Replace the injection actuation pressure control valve. Verify that the problem is resolved.

STOP.

Test Step 7. Use the “Injection Act Press Driver Test” on the Electronic Service Tool to Check the ECM.

A. Disconnect the ECM engine harness connector J2/P2.

B. Turn the ignition key switch to the ON position.

C. Access the “Injection Act Press Driver Test” in the “Diagnostics” menu of the electronic service tool.

D. Connect a breakout T to the ECM engine harness connector J2.

E. Connect a voltage test lamp to the engine harness connector for the injection actuation pressure control valve, terminal 61 and terminal 62 of the breakout T.

F. Start and stop the “Injection Act Press Driver Test”.

Note: This test procedure may cause a 42-11 Injection Actuation Pressure Control Valve Driver (18). This is normal.

Expected Result:

The voltage test lamp should come on when the test is active.

Note: Personality Modules with a manufactured date before JUNE 99 require an electrical connector for the injection actuation pressure sensor to be disconnected in order for the "Injection Actuation Pressure Control Valve Driver Special Test" to turn off the driver for the injection actuation pressure control valve. If the connector J204/P204 for the injection actuation pressure sensor is not disconnected, the voltage test lamp will remain on when the special test is not active.

Results:

- Yes

Repair: Replace the harness for the injection actuation pressure control valve.

STOP.

- No

Repair: Temporarily install a test ECM. Repeat the test step. If this corrects the problem, then reinstall the old ECM and verify that the problem reoccurs. Replace the ECM if the problem reoccurs with the old ECM.

STOP.

i01857920

Injection Actuation Pressure Sensor - Test

SMCS Code: 1925-081

System Operation Description:

Use this procedure under the following situation:

Use the following information in order to troubleshoot the system when there is an active code:

- 164-02 Injection Actuation Pr Sensor Erratic (15)

Note: This procedure can check the accuracy of the injection actuation pressure sensor against a pressure gauge.

The following background information is related to the following procedure:

The injection actuation pressure sensor measures the pressure of the oil in the high pressure oil manifold. The high pressure oil in the manifold is used to actuate the injectors and the high pressure oil is used to control the fuel injection pressure. Fuel injection pressure is based on inputs from the sensors. The inputs are used by the ECM for calculating the fuel injection pressure. The ECM uses the reading from the injection actuation pressure sensor in order to control the operation of the injection actuation pressure control valve.

Injection Actuation Pressure Sensor

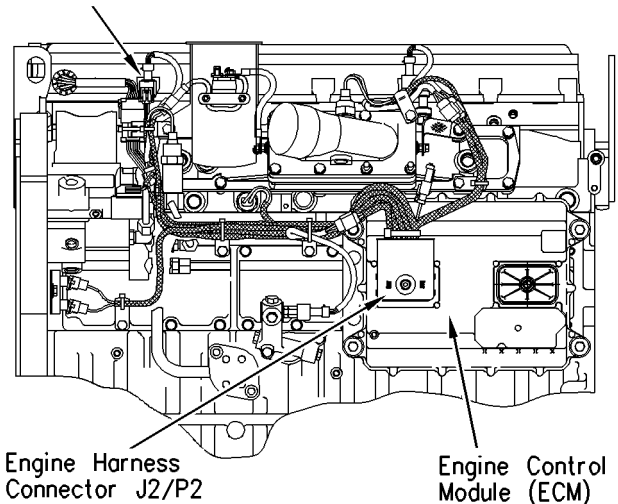

Illustration 129

g00725343

location of the injection actuation pressure control valve

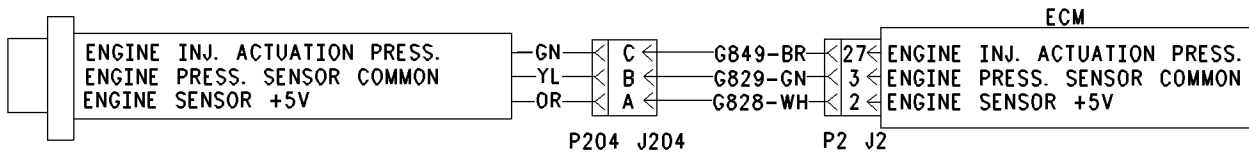

Illustration 130

g00725355

Schematic for the injection actuation pressure sensor

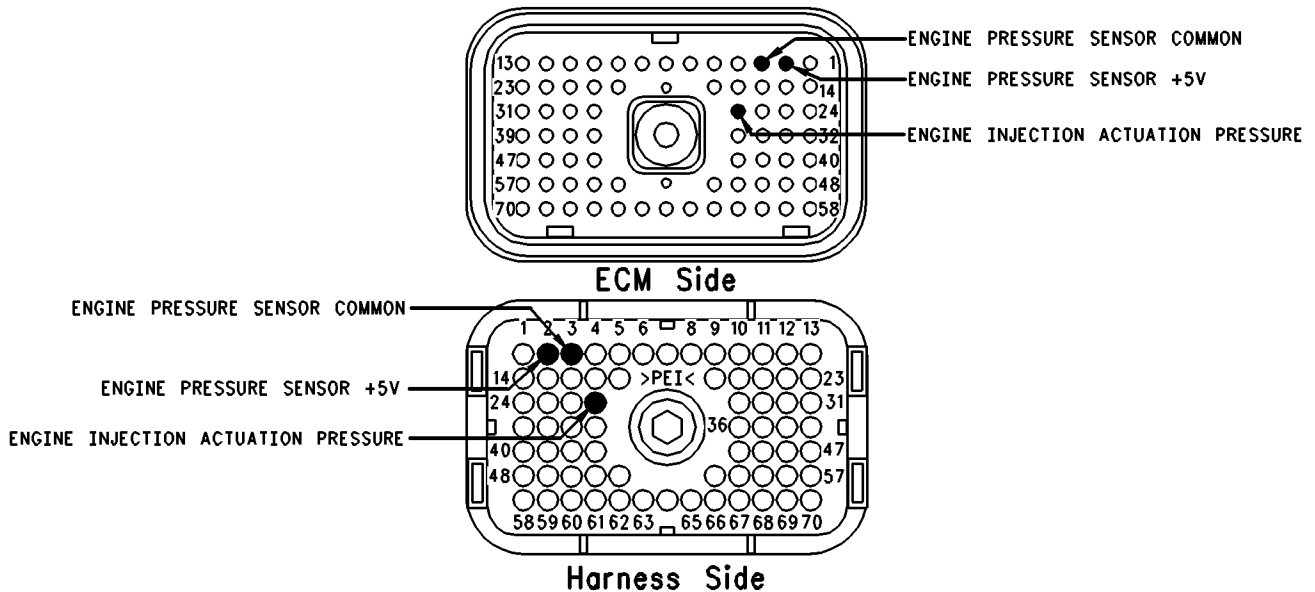

Illustration 131

g00725426

Locations for the ECM terminals

Test Step 1. Use an Electronic Service Tool to Check for Active Diagnostic Codes.

- A. Connect the electronic service tool to the cab data link connector.
- B. Turn the ignition key switch to the ON position.

Note: If the 164-02 Injection Actuation Pr Sensor Erratic (15) is not active or logged, try to start the engine.

Note: If 164-03 Injection Actuation Pr Sensor Open Circuit (15) or 164-04 Injection Actuation Pr Sensor Short Circuit (15) is active, refer to Troubleshooting, "Engine Pressure Sensor Open or Short Circuit-Test".

Expected Result:

164-02 Injection Actuation Pressure Erratic is active.

Results:

- Yes – The engine will not start. Proceed to Test Step 2.
- No – The engine will not start. Proceed to Test Step 2.

Test Step 2. Disconnect the Injection Actuation Pressure Sensor and Start the Engine.

- A. Turn the ignition key switch to the OFF position.
- B. Disconnect the electrical connector J204/P204 for the injection actuation pressure sensor from the engine harness.
- C. Try to start the engine.

Expected Result:

The engine starts.

Results:

- Yes – Proceed to Test Step 3.
- No

Repair: Reconnect the electrical connector J204/P204 for the injection actuation pressure sensor to the engine harness. Refer to Troubleshooting, “Engine Cranks but Will Not Start”.

STOP.

Test Step 3. Inspect Electrical Connectors and Wiring.

- Thoroughly inspect the connector J204/P204 for the injection actuation pressure sensor and inspect the ECM engine harness connector J2/P2. Refer to Troubleshooting, “Electrical Connectors-Inspect” for details.
- Perform a 45 N (10 lb) pull test on each of the wires in the ECM connector that are associated with the injection actuation pressure sensor (terminals 61 and terminal 62).
- Check the ECM connector (allen head screw) for the proper torque of 6.0 N·m (55 lb in).
- Check the harness and wiring for abrasion and for pinch points from the sensors back to the ECM.

Expected Result:

All connectors, pins and sockets should be completely coupled and/or inserted and the harness and wiring should be free of corrosion, abrasion or pinch points.

Results:

- OK – Proceed to Test Step 4.
- Not OK

Repair: Perform the following repair:

Repair the connectors or wiring and/or replace the connectors or wiring. Ensure that all of the seals are properly in place and ensure that the connectors are completely coupled.

Verify that the repair eliminates the problem.

STOP.

Test Step 4. Check the Sensor Status with the Engine Off.

- Connect the electronic service tool to the cab data link connector.
- Turn the ignition key switch to the ON position.
- Check the injection actuation pressure on the electronic service tool status screen.

Note: The following codes will cause the injection actuation pressure sensor to default to 17500 kPa (2538 psi).

- 164-03 Injection Actuation Pr Open Circuit (15)
- 164-04 Injection Actuation Pr Sensor Short Circuit (15)
- 232-03 5 Volt Supply Above Normal (21)
- 232-04 5 Volt Supply Below Normal (21)

Expected Result:

The injection actuation pressure sensor indicates 0 kPa (0 psi).

Results:

- Yes – Proceed to Test Step 6.
- No – Proceed to Test Step 5.

Test Step 5. Check the Voltage Supply of the Injection Actuation Pressure Sensor.

- Turn the ignition key switch to the OFF position.
- Disconnect the electrical connector J204/P204 for the injection actuation pressure sensor from the engine harness.
- Connect a 3-Terminal breakout T to the electrical connector J204 only.
- Turn the ignition key switch to the ON position.
- Use a digital multimeter that is set on DC voltage. Measure the voltage supply from terminal A to Terminal B at the breakout T.

Expected Result:

The voltage reading should be between 4.5 to 5.5 VDC.

Results:

- Yes – Proceed to Test Step 6.
- No

Repair: The voltage supply for the injection actuation pressure sensor is not correct. Refer to Troubleshooting, “5 Volt Engine Pressure Sensor Supply Circuit - Test”.

STOP.

Test Step 6. Compare the Injection Actuation Pressure Sensor Reading to a Pressure Gauge Reading.



WARNING

Escaping fluid under pressure, even a pinhole size leak, can penetrate body tissue, causing serious injury, and possible death. If fluid is injected into your skin, it must be treated immediately by a doctor familiar with this type of injury.

Always use a board or cardboard when checking for a leak.

- A.** Turn the ignition key switch to the OFF position.
- B.** Install a 8T-0852 Pressure Gauge to an oil supply port on the high pressure oil rail that is located on the cylinder head.
- C.** Connect the electronic service tool to the cab data link connector.
- D.** Start the engine.
- E.** Go to the “Injection Actuation Pressure Test” on the Diagnostic Menu of the electronic service tool.
- F.** Start the test and monitor the Injection Actuation Pressure Sensor reading from the electronic service tool. Compare the pressure reading from the electronic service tool to the pressure reading on the 8T-0852 Pressure Gauge. Perform a comparison of the two different pressure indicators at varying engine rpm.

Note: Use Table 173 for the approximate range for the injection actuation pressure sensor. Compare the 8T-0852 Pressure Gauge pressure reading to the pressure reading from the table.

Table 173

Service Tool Pressure Reading	Pressure Gauge Reading Range
6000 kPa	4000-7800 kPa (580-1130 psi)
10000 kPa	8000-11800 kPa (1160-1710 psi)
15000 kPa	13000-16800 kPa (1885-2435 psi)
23000 kPa	21000-24800 kPa (3045-3595 psi)

Expected Result:

The reading that is displayed on the electronic service tool and the reading on the pressure gauge readings agree.

Results:

- Yes

Repair: The injection actuation pressure sensor and the ECM are working properly. Refer to Troubleshooting, “Troubleshooting without a Diagnostic Code”.

STOP.

- No

Repair: Temporarily replace the injection actuation pressure sensor and repeat the test. Replace the injection actuation pressure sensor if this corrects the problem. If the new sensor is out of the range, then the pressure gauge is faulty.

STOP.

i01632162

Injector Solenoid Circuit - Test

SMCS Code: 1290-038

System Operation Description:

Use this procedure under the following situation:

Use this procedure if any of the following diagnostic codes are present:

- 1-11 Cylinder 1 Fault (72)
- 2-11 Cylinder 2 Fault (72)
- 3-11 Cylinder 3 Fault (73)
- 4-11 Cylinder 4 Fault (73)

- 5-11 Cylinder 5 Fault (74)
- 6-11 Cylinder 6 Fault (74)

Also use this procedure if you have been referred to this test from Troubleshooting, "Engine Misfires, Runs Rough or Is Unstable " or Troubleshooting, "Low Power/Poor or No Response to Throttle".

Perform this procedure under conditions that are identical to the conditions that exist when the problem occurs. Typically, problems with the injector solenoid occur when the engine is warmed up and/or when the engine is under vibration (heavy loads).

The following background information is related to this procedure:

The engines use Hydraulic Electronic Unit Injectors that are hydraulically actuated and electronically energized. The solenoid is mounted on top of the fuel injector body.

The injectors can be individually cut out to aid in troubleshooting misfire problems. Use the Cylinder Cutout Test to disable individual injectors.

The injector solenoids can also be actuated without running the engine in order to check the operation of the solenoids. Use the Injector Solenoid Test to perform this function.

Note: The Injector Solenoid Test will not help find leaks in the high pressure oil system.

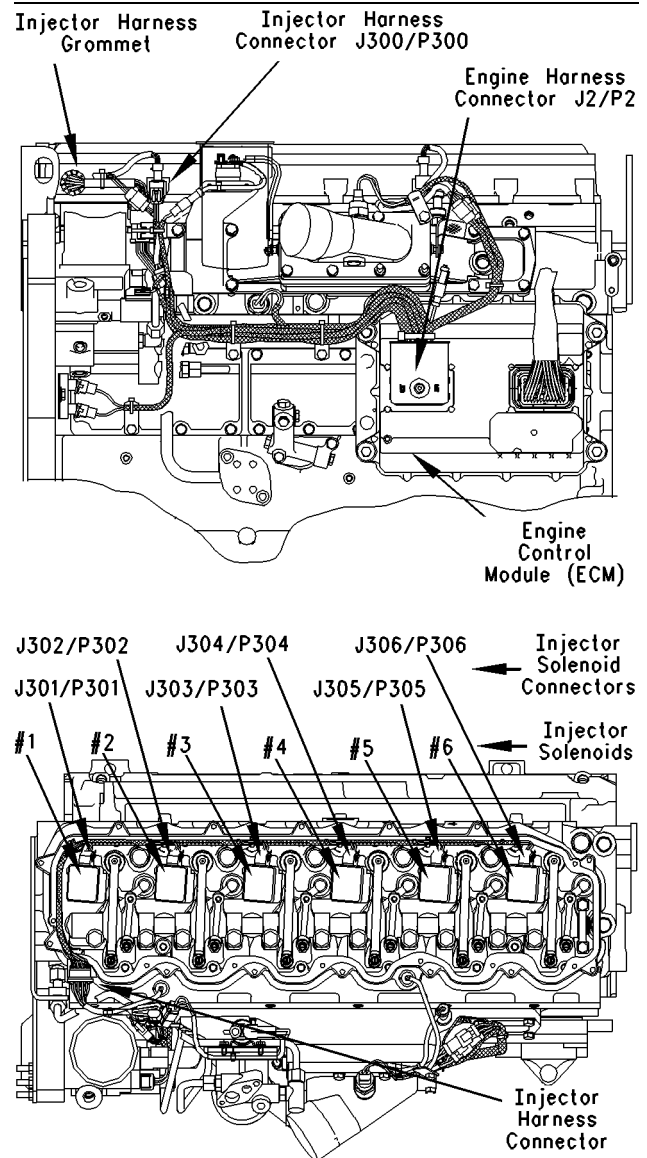

Illustration 132

g00723522

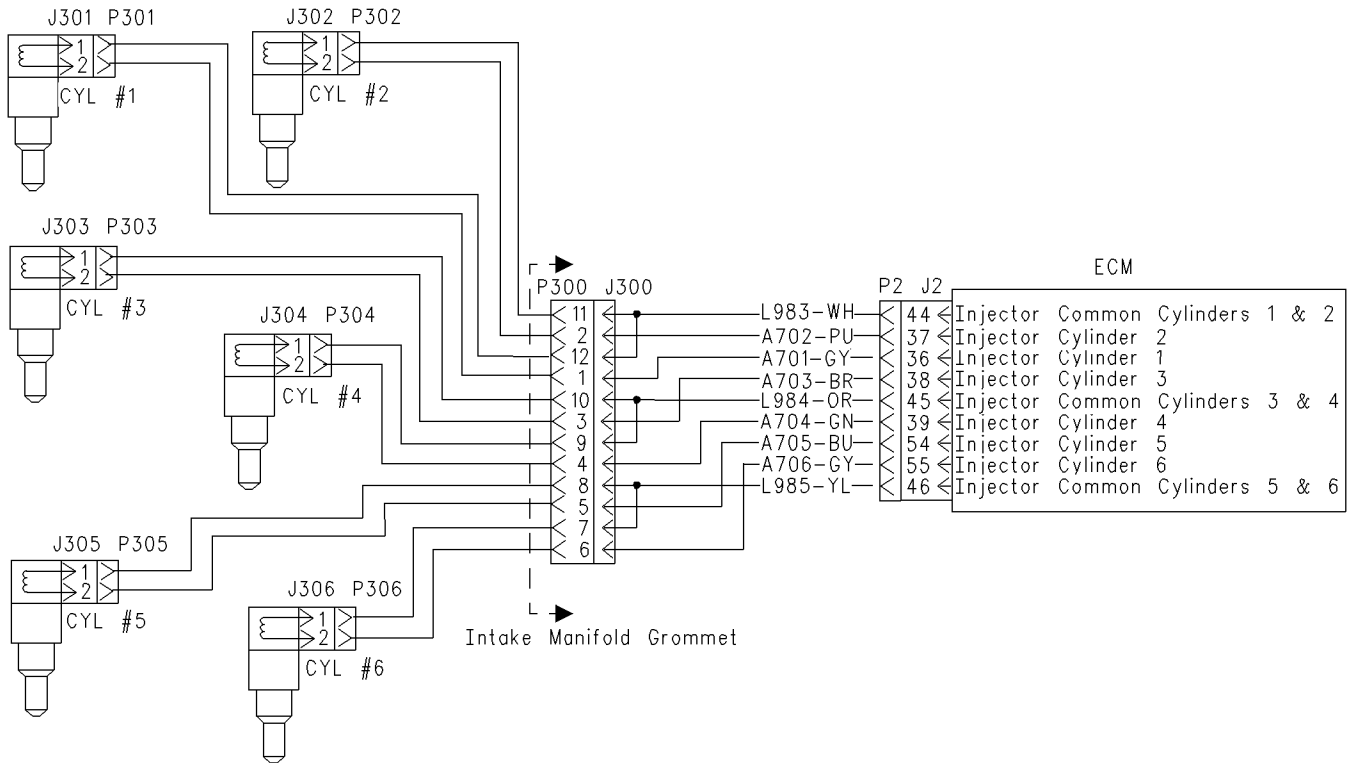

Illustration 133
Circuit schematic for the injectors

g00782844

Test Step 1. Inspect Electrical Connectors and Wiring.

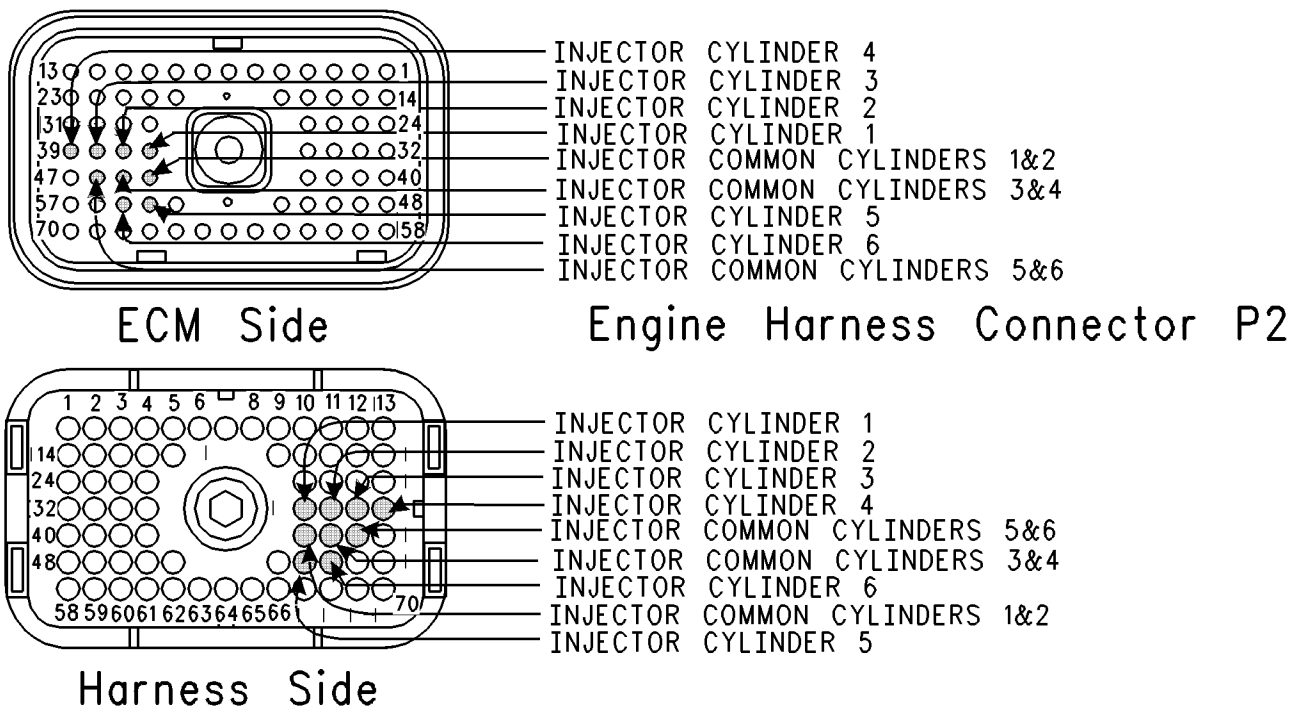

Illustration 134
Pin locations for ECM

g00723444

 **WARNING**

Electrical shock hazard. The electronic unit injector system uses 90-120 volts.

- A.** Turn the ignition key switch to the OFF position. A strong electrical shock hazard is present if the ignition key is not turned OFF.
- B.** Thoroughly inspect the ECM engine harness connector J2/P2 and the solenoid connector for the injector J300/P300. Refer to Troubleshooting, “Electrical Connectors - Inspect” for details.
- C.** Perform a 45 N (10 lb) pull test on each of the wires in the ECM connector and the solenoid connector for the injector J300/P300 that are associated with injector solenoids.

Refer to Illustration 134.
- D.** Check the ECM connector (allen head screw) for the proper torque of 6.0 N·m (55 lb in).
- E.** Check the solenoid connector for the injector J300/P300 in order to ensure the proper mating of the connector.
- F.** Check the harness and wiring for abrasion and pinch points from the injectors to the ECM.

Expected Result:

All connectors, pins and sockets should be completely coupled and/or inserted and the harness and wiring should be free of corrosion, abrasion or pinch points.

Results:

- OK – Proceed to Test Step 2.
- Not OK

Repair: Perform the following repair:

Repair the connectors or wiring and/or replace the connectors or wiring. Ensure that all of the seals are properly in place and ensure that the connectors are completely coupled.

Verify that the repair eliminates the problem.

STOP.

Test Step 2. Use ET to Check for Logged Diagnostic Codes.

- A.** Connect ET to the cab data link connector.

- B.** Turn the ignition key switch to the ON position.
- C.** Monitor the “Logged Diagnostic Code” screen of ET.

Expected Result:

One or more of the listed codes have been logged:

- 1-11 Cylinder 1 Fault (72)
- 2-11 Cylinder 2 Fault (72)
- 3-11 Cylinder 3 Fault (73)
- 4-11 Cylinder 4 Fault (73)
- 5-11 Cylinder 5 Fault (74)
- 6-11 Cylinder 6 Fault (74)

Results:

- Yes – Proceed to Test Step 4.
- No – Proceed to Test Step 3.

Test Step 3. Check the Variation of the Injectors From Cylinder to Cylinder.

- A.** Connect ET to the cab data link connector.
- B.** When possible, put the truck on a dynamometer.
- C.** Start the engine.
- D.** Allow the engine to warm up to normal operating temperature 77 °C (171 °F).
- E.** After the engine is warmed to operating temperature, access the “Cylinder Cutout Test” by accessing the following display screens in order:
 - “Diagnostics”
 - “Diagnostic Tests”
 - “Cylinder Cutout Test”
- F.** Enable the cooling fan, if the fan is not controlled by the ECM. If the ECM controls the cooling fan, the cooling fan will start automatically when the test begins.
- G.** Shut off all parasitic loads such as the air conditioning and the air compressors which could affect the results of the test.
- H.** Cut out each cylinder and watch the “Fuel Position” of all of the other cylinders.

- I. Verify that cutting out a specific cylinder causes only a slight change to the Fuel Position of the other cylinders in comparison to the change to the Fuel Position that occurs when other cylinders are cut out. If a cylinder is cut out and only a slight change occurs to the Fuel Position of the other cylinders, a mechanical problem with the injector or a mechanical problem with the cylinder may exist.
- J. After the test is finished, use ET to check for active diagnostic codes or for logged diagnostic codes that are new.

Expected Result:

An active diagnostic code for a cylinder fault results from running the Cylinder Cutout Test.

Results:

- **Yes** – Proceed to Test Step 4.
- **No** – Perform the following repair:

Repair: If a cylinder is cut out and only a slight change occurs to the Fuel Position of the other cylinders, a mechanical problem with the injector or a mechanical problem with the cylinder may exist. If the engine is misfiring or if the engine has low power, refer to Troubleshooting, “Engine Misfires, Runs Rough or Is Unstable” and Troubleshooting, “Low Power/Poor or No Response to Throttle”.

If a diagnostic code for a cylinder fault results from running the Cylinder Cutout test, proceed to Test Step 4.

Test Step 4. Use the Injector Solenoid Test to Test the Injector Solenoids.

- A. Start the engine.
- B. Allow the engine to warm up to 77 °C (171 °F) which is the normal operating temperature.
- C. Turn the ignition key switch to the OFF position.
- D. Connect ET at the cab data link connector.
- E. Turn the ignition key switch to the ON position.
- F. After the engine is warmed to operating temperature, access the “Injector Solenoid Test” by accessing the following display screens in order:
- “Diagnostics”
 - “Diagnostic Tests”
 - “Injector Solenoid Test”

- G. Activate the test.

Note: Do not confuse the Injector Solenoid Test with the Cylinder Cutout Test. The Cylinder Cutout Test is used to shut off fuel to a specific cylinder while the engine is running. The Injector Solenoid Test is used in order to actuate the injector solenoids. This allows the click of the injector solenoids to be heard when the engine is not running in order to determine that the circuit is functioning properly.

- H. As each solenoid is energized by the ECM an audible click can be heard at the valve cover. A black square will appear over the cylinder number when the cylinder is being fired.

- I. Perform the Injector Solenoid Test at least two times.

Expected Result:

All cylinders indicate “OK”.

Results:

- **Yes** – There is not an electronic problem with the injectors at this time. **STOP.**
- **No** – ET displays “SHORT” for any cylinder. Proceed to Test Step 5.
- **No** – ET displays “OPEN” for any cylinder. Proceed to Test Step 6.

Test Step 5. Check the Injector Harness from P2 to J300 for Short Circuits.
 **WARNING**

Electrical shock hazard. The electronic unit injector system uses 90-120 volts.

- A. Turn the ignition key switch to the OFF position. A strong electrical shock hazard is present if the ignition key switch is not turned off.
- B. Disconnect the 12-pin connector (J300/P300). Check for evidence of moisture entry. Refer to Troubleshooting, “Electrical Connectors - Inspect” for details.
- C. Turn the ignition key switch to the ON position.
- D. Access the “Injector Solenoid Test” on ET and begin the test.

Expected Result:

The status of the circuit for the suspect injector displays "SHORT" before J300/P300 is disconnected. The status of the circuit for the suspect injector changes to "OPEN" after J300/P300 is disconnected.

Results:

- **Yes** – Reconnect J300/P300. Proceed to Test Step 7.
- **No** – Proceed to Test Step 8.

Test Step 6. Check the Injector Harness from P2 to J300 for an Open Circuit.

 **WARNING**

Electrical shock hazard. The electronic unit injector system uses 90-120 volts.

- Turn the ignition key switch to the OFF position. A strong electrical shock hazard is present if the ignition key switch is not turned off.
- Disconnect the 12-pin connector (J300/P300).
- Insert one end of a jumper wire into the socket of the suspect injector. Insert the other end of the jumper wire into the socket of the injector common line for the connector (J300/P300).
- Turn the ignition key switch to the ON position.
- Access the "Injector Solenoid Test" on ET and begin the test.

Expected Result:

The status of the circuit for the suspect injector displays "OPEN" before J300/P300 is disconnected. The status of the circuit for the suspect injector changes to "SHORT" after J300/P300 is disconnected.

Results:

- **Yes** – Proceed to Test Step 9.
- **No** – Proceed to Test Step 10.

Test Step 7. Check the Injector Harness for a Short Circuit Between Connector P300 and the Injector.

 **WARNING**

Electrical shock hazard. The electronic unit injector system uses 90-120 volts.

- Turn the ignition key switch to the OFF position. A strong electrical shock hazard is present if the ignition key is not turned OFF.
- Remove the valve cover.
- Disconnect the harness from the problem injector at the connector that is attached to the injector solenoid. For example, if the number one injector is the suspect injector, disconnect P301 from J301.
- Turn the ignition key switch to the ON position.
- Access the "Injector Solenoid Test" on ET and perform the test three times.

Note: Ensure that the seal is installed in the harness connector before connecting the harness to the connector. If the seal is missing, use a replacement seal. Ensure that the seal is not stuck in the injector connector.

Expected Result:

The status for the injector that is disconnected changes to "OPEN" when the harness is disconnected.

Results:

- **Yes** – Perform the following repair:

Repair: Temporarily connect a new injector to the harness. Run the "Injector Solenoid Test". If all cylinders indicate "OK", turn the keyswitch to OFF and reconnect the old injector. If the original injector again reads "OPEN", replace the injector. Restore the wiring to the proper injectors. Use the "Injector Solenoid Test" to verify that the repair eliminates the problem.

Do not install the valve cover until the problem is resolved. Clear all diagnostic codes.

STOP.

- **No** – Perform the following repair:

Repair: There is a short in the wiring harness. Replace the wiring harness between the 12-pin connector (P300) and the injector.

Verify that the repair eliminates the problem.

STOP.

Test Step 8. Use the “Injector Solenoid Test” to Check for Short Circuits in the ECM and in the Harness.

⚠ WARNING

Electrical shock hazard. The electronic unit injector system uses 90-120 volts.

- A. Turn the ignition key switch to the OFF position. A strong electrical shock hazard is present if the ignition key is not turned OFF.
- B. Disconnect ECM engine harness connector “J2/P2” from the ECM and check for evidence of moisture entry. Refer to Troubleshooting, “Electrical Connectors - Inspect” for details.
- C. Turn the ignition key switch to the ON position.
- D. Access the “Injector Solenoid Test” on ET and begin the test.

Note: When ECM Connector J2/P2 is disconnected, all of the open circuit diagnostic codes for the sensors and the open circuit diagnostic code for the Air Inlet Heater will be active. This is normal. Clear all diagnostic codes after completing this test step.

Expected Result:

All cylinders indicate “OPEN” when the engine harness connector P2 is disconnected from the ECM.

Results:

- **Yes** – Repair the harness between the ECM Connector P2 and the 12-pin connector (J300). If the harness cannot be repaired, replace the harness. **STOP**.
- **No** – Temporarily connect a test ECM. Repeat this test step. If the problem is resolved with the test ECM, install the old ECM in order to verify that the problem returns. If the test ECM works and the old ECM does not work, replace the ECM. **STOP**.

Test Step 9. Check the Injector Harness for an Open Circuit Between Connector P300 and the Injector.

⚠ WARNING

Electrical shock hazard. The electronic unit injector system uses 90-120 volts.

- A. Turn the ignition key switch to the OFF position. A strong electrical shock hazard is present if the ignition key is not turned OFF.
- B. Remove the valve cover.
- C. Disconnect the harness from the problem injector at the connector that is attached to the injector solenoid. For example, if the number one injector is the suspect injector, disconnect P301 from J301.

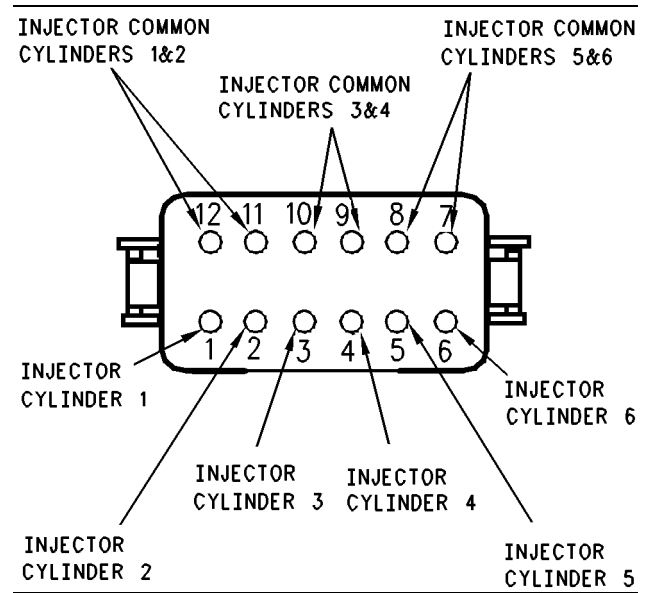

Illustration 135 Connector for injector solenoids g00723455

- D. Insert a jumper wire across the terminals of the harness connector that was removed from the injector. For example, if the number one injector is the suspect injector, place the jumper wire across the terminals of “P301”.
- E. Turn the ignition key switch to the ON position.
- F. Access the “Injector Solenoid Test” on ET and monitor the cylinder.

Expected Result:

The status of the injector with the short in place indicates an “OPEN”.

Results:

- **Yes** – There is an open circuit in the harness. Repair the harness between the 12-pin connector (J300) and the injector. Replace the harness if the harness cannot be repaired. Verify that the repair eliminates the problem. **STOP**.

- **No**

Repair: Temporarily connect a new injector to the harness. Run the “Injector Solenoid Test”. If all cylinders indicate “OK”, turn the keyswitch to OFF and reconnect the old injector. If the original injector again reads “OPEN”, replace the injector. Restore the wiring to the proper injectors. Use the “Injector Solenoid Test” to verify that the repair eliminates the problem.

Do not install the valve cover until the problem is resolved. Clear all diagnostic codes.

STOP.

Test Step 10. Use the “Injector Solenoid Test” to Check for Open Circuits in the ECM and in the Harness.

 **WARNING**

Electrical shock hazard. The electronic unit injector system uses 90-120 volts.

- Turn the ignition key switch to the OFF position. A strong electrical shock hazard is present if the ignition key is not turned OFF.
- Disconnect ECM engine harness connector “J2/P2” from the ECM and check for evidence of moisture entry. Refer to Troubleshooting, “Electrical Connectors - Inspect” for details.
- Connect a 70-Terminal breakout T into the ECM. Do not connect the engine harness connector P2 into the breakout T.
- Use a jumper wire to short between the socket of the suspect injector and the common socket of the suspect injector.
- Turn the ignition key switch to the ON position.
- Access the “Injector Solenoid Test” on ET and begin the test.

Note: When ECM connector J2/P2 is disconnected, all of the open circuit diagnostic codes for the sensors and the open circuit diagnostic code for the air inlet heater will be active. All of the injectors that are not jumpered will indicate an OPEN circuit during the “Injector Solenoid Test”. This is normal. Clear all diagnostic codes after completing this test step.

Expected Result:

ET displays “SHORT” for the cylinder with the jumper wire.

Results:

- **Yes** – Repair the harness between the 12-pin connector (J300) and the ECM connector P2. Replace the harness if the harness cannot be repaired. **STOP**.
- **No** – Temporarily connect a test ECM. Repeat this test step. If the problem is resolved with the test ECM, install the old ECM in order to verify that the problem returns. If the test ECM works and the old ECM does not work, replace the ECM. **STOP**.

i01858012

Input Selection Switch Circuit - Test

SMCS Code: 1900-081-ZS

System Operation Description:

Use this procedure under the following situation:

Use this procedure to determine if the following circuits are operating correctly:

- Torque limit switch
- Ignore brake/clutch switch
- Two-speed axle switch
- Diagnostic enable switch
- PTO Engine RPM Set Speed Input A Switch
- PTO Engine RPM Set Speed Input B Switch

The following background information is related to this procedure:

The ECM can use various inputs in a number of ways. The inputs depend on the parameter programming. Certain features are available on several different inputs. The configuration for the switch must match the actual switch installation in order for the switch to function properly.

Input 4 (Torque Limit Switch)

MAR98 and Newer Software

The torque limit switch provides a way to temporarily protect equipment from damage that is caused by applying too much torque. Torque limiting is typically used during PTO operation. Torque limiting can also be used when the PTO on/off switch is in the OFF position.

In order to use torque limiting, the parameter "Torque Limit" must be programmed. The "Torque Limit" parameter is located under the "Dedicated PTO Parameters". The default setting is 2712 N·m (2000 lb ft). The "Input # 4" parameter must be programmed to "Torque Limit Switch". If the "Input # 4" parameter is programmed to "None" (default), this feature is not used.

OCT01 Software

The parameter "Input # 4" has been replaced by the parameter "Torque Limit Switch". This parameter can be programmed to "J1/P1:7", "J1/P1:23", or "None".

Input 5 (Ignore Brake/Clutch Switch)

MAR98 and Newer Software

The ignore brake/clutch switch is typically used when the parameter "PTO Configuration" is programmed to "Cab Switches". This configuration requires mobile use of the vehicle during PTO operation. When the ignore brake/clutch switch is on, depressing the brake or the clutch will not disengage PTO operation or a set engine speed. If the "Input # 5" parameter is programmed to "None" (default), this feature is not used. For information on troubleshooting this switch, refer to Troubleshooting, "Ignore Brake/Clutch Switch Circuit - Test".

OCT01 Software

The parameter "Input # 5" has been replaced by the parameter "Ignore Brake/Clutch Switch". This parameter can be programmed to "J1/P1:47" or "None".

Input 6 (Two-Speed Axle Switch)

MAR98 and Newer Software

When a two-speed axle is used, the change in gear ratios from the main drive axle ratio will alter the calibration of the vehicle speed signal. When the two-speed axle switch is in the ON position, the ECM will automatically adjust the vehicle speed calibration. This will ensure that the ECM driven speedometer and the stored information in the ECM correctly reflect the actual vehicle speed. In order for this feature to function properly, the "Low Speed Range Axle Ratio" and "High Speed Range Axle Ratio" parameters must be programmed. If the "Input # 6" parameter is programmed to "None" (default), this feature is not used.

OCT01 Software

The parameter "Input # 6" has been replaced by the parameter "Two-Speed Axle Switch". This parameter can be programmed to "J1/P1:6" or "None".

Input 7 (Diagnostic Enable Switch)

JUL99 and Newer Software

The diagnostic enable switch is used to prompt diagnostic flash codes on the check engine lamp. For more information, refer to Troubleshooting, "Flash Programming" and Troubleshooting, "Check Engine Lamp or Warning Lamp is Malfunctioning". If the "Input # 7" parameter is programmed to "None" (default), then the feature is not used. If the "Input # 7" parameter is programmed to "Diagnostic Enable Switch", then the feature is available and the switch circuit should be connected to terminal 46 of the J1/P1 ECM vehicle harness connector.

OCT01 Software

The parameter "Input # 7" is no longer used. "Diagnostic Enable" is the parameter that is used to configure a diagnostic enable switch. This parameter can be programmed to "J1/P1:46", "J1939 Cab Controller", "J1939 Body Controller", "J1939 Instrument Cluster", or "None". For troubleshooting the J1939 options, refer to Troubleshooting, "Powertrain Data Link Circuit - Test".

JUL99 and Newer Software

"Input # 7" can be programmed to "Diagnostic Enable Switch" or to "PTO Engine RPM Set Speed Input A". If the "Input # 7" parameter is programmed to "PTO Engine RPM Set Speed Input A" the switch is used to control engine speed during PTO operation. The switch circuit should be connected to terminal 46 of the J1/P1 ECM vehicle harness connector. The "PTO Configuration" parameter must be programmed to "Cab Switches", "Remote Switches" or "Remote Throttle" and the "PTO Engine RPM Speed Input A" parameter must be programmed to a valid speed.

The “PTO Engine RPM Set Speed A” parameter requires an engine rpm to be programmed. The “PTO Engine RPM Set Speed A” parameter is located in the “Dedicated PTO Parameter Group”. The “Input # 7” parameter is located in the “Input Selections Parameter Group”. The engine will ramp up to the engine rpm that is programmed under the following conditions:

- The switch for the PTO Engine RPM Set Speed Input A Switch is in the ON position and the PTO on/off switch is then turned on.
- The switch for the PTO Engine RPM Set Speed Input A Switch is turned to the ON position when the PTO on/off switch is on.

The PTO on/off switch or the switch for the PTO Engine RPM Set Speed Input A must be cycled from the OFF position to the ON position in order to return to the programmed engine rpm if the PTO operation is disabled.

OCT01 Software

The parameter “Input # 7” is no longer used. “PTO Engine RPM Set Speed Input A” is the parameter that is used to configure a PTO Engine RPM Set Speed Input A switch. This parameter can be programmed to “J1/P1:46”, or “None”. The “PTO Configuration” parameter must be programmed to “Cab Switches”, “Remote Switches” or “Remote Throttle” and the “PTO Engine RPM Speed A” parameter must be programmed to a valid speed.

Input 19 (PTO Engine RPM Set Speed Input B Switch)

JUL99 and Newer Personality Modules.

“Input # 19” can be programmed to “PTO Engine RPM Set Speed Input B” or to “None”. If the “Input # 19” parameter is programmed to “PTO Engine RPM Set Speed Input B”, the switch is used to control engine speed during PTO operation. The “PTO Configuration” parameter must be programmed to “Cab Switches”, “Remote Switches” or “Remote Throttle” and the “PTO Engine RPM Speed B” parameter must be programmed to a valid speed.

The “PTO Engine RPM Set Speed B” parameter requires an engine rpm to be programmed. The “PTO Engine RPM Set Speed B” parameter is located in the “Dedicated PTO Parameter Group”. The “PTO Engine RPM Set Speed Input B” parameter is located in the “Input Selections Parameter Group”. The function of the switch for the “PTO Engine RPM Set Speed Input B” is similar to the function of the switch for the “PTO Engine RPM Set Speed Input A”. The engine will operate at Set Speed “A” when both of the switches are on. If the “PTO Engine RPM Set Speed Input B” parameter is programmed to “None” (default), this feature is not used.

OCT01 Software

The parameter “Input # 19” is no longer used. “PTO Engine RPM Set Speed Input B” is the parameter that is used to configure a PTO Engine RPM Set Speed Input B switch. This parameter can be programmed to “J1/P1:7”, “J1/P1:23”, or “None”. The “PTO Configuration” parameter must be programmed to “Cab Switches”, “Remote Switches” or “Remote Throttle” and the “PTO Engine RPM Speed B” parameter must be programmed to a valid speed.

Note: The wiring for your particular application may be slightly different. The circuits for the sensor common are used interchangeably by the OEM of the vehicle. The following circuits are common within the ECM:

- The “Input Sensor Common 1” is terminal 18.
- The “Input Sensor Common 2” is terminal 3.
- The “AP Sensor/Switch Sensor Common” is terminal 5.

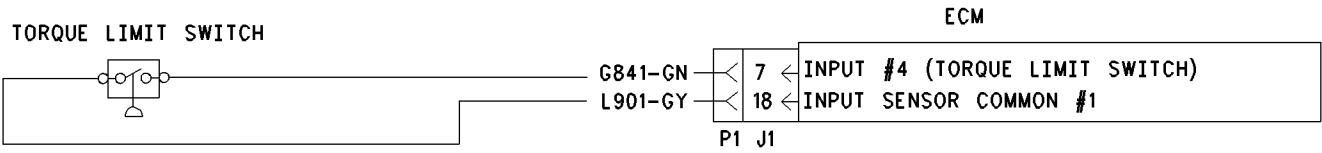

Illustration 136

g00728802

Schematic for Torque Limit Switch

OCT01 Software may also be configured to use J1/P1:23 for the Torque Limit Switch.

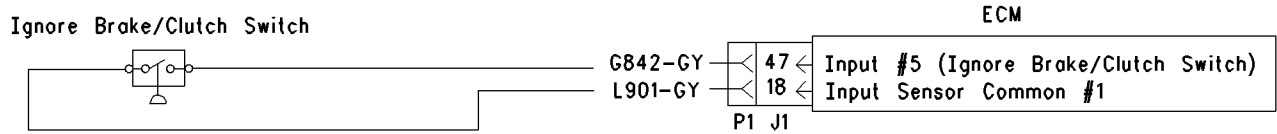

Illustration 137

g00682286

Schematic for ignore brake/clutch switch

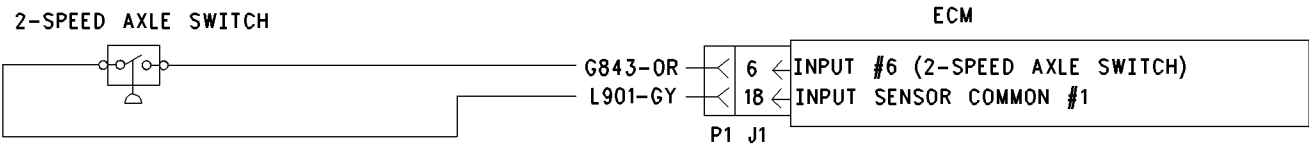

Illustration 138

g00682705

Schematic for Two Speed Axle Switch Circuit

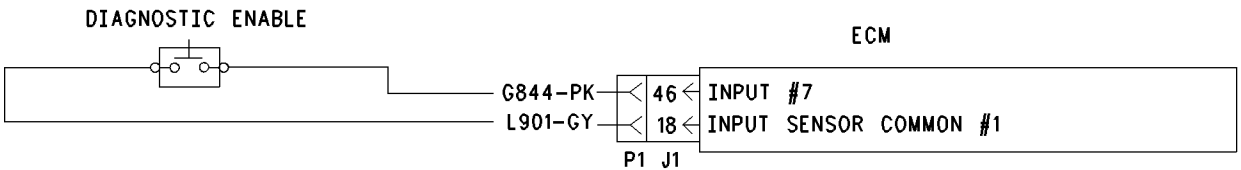

Illustration 139

g00728804

Schematic for Diagnostic Enable Switch or the PTO Engine RPM Set Speed Input A Switch

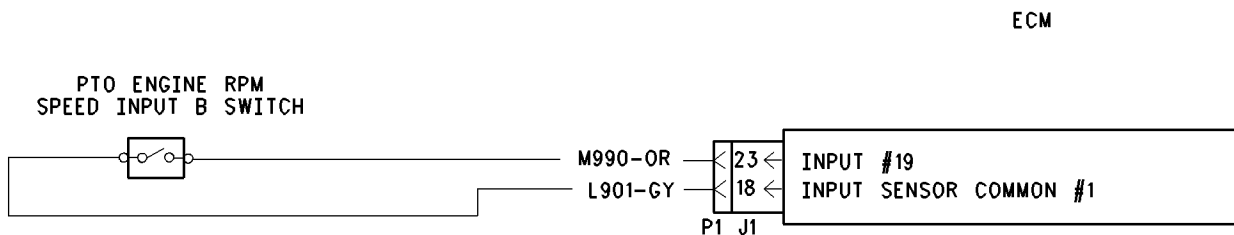

Illustration 140

g00728803

Schematic for the PTO Engine RPM Set Speed Input B Switch

OCT01 Software may also be configured to use J1/P1:7 for the PTO Engine RPM Set Speed Input B Switch.

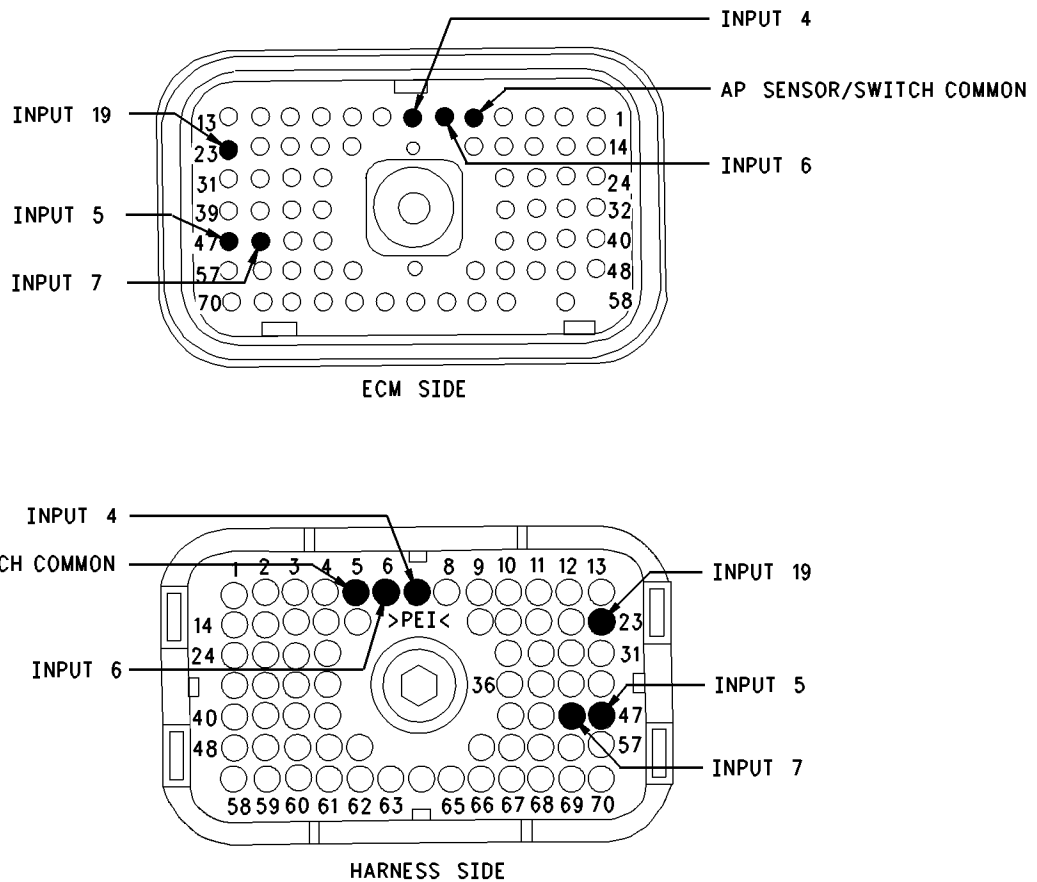

Illustration 141
Terminal Locations for ECM

g00728814

Test Step 1. Inspect Electrical Connectors and Wiring

- A. Thoroughly inspect the ECM vehicle harness connector J1/P1, the connectors, and the firewall bulkhead connectors. Refer to Troubleshooting, “Electrical Connectors - Inspect” for details.
- B. Perform a 45 N (10 lb) pull test on each of the wires in the ECM connector that are associated with the suspect switch circuit.
- C. Check the ECM connector (allen head screw) for the proper torque of 6.0 N·m (55 lb in).
- D. Check the harness and the wiring for abrasion and for pinch points from the battery to the ECM. Then, check from the ignition key switch to the ECM.

Refer to Illustration 141 for terminal locations for the ECM.

Expected Result:

All connectors, pins, and sockets are completely coupled and/or inserted, and the harness and wiring should be free of corrosion, abrasion or pinch points.

Results:

- OK – Proceed to Test Step 2.
- Not OK – Repair the wiring and connectors or replace the wiring or the connectors. Ensure that all of the seals are properly connected. Verify that the repair eliminates the problem. STOP.

Test Step 2. Check the Switch Status on an Electronic Service Tool

- A. Connect the electronic service tool to the cab data link connector.
- B. Turn the ignition key switch to the ON position.

- C. Operate the switch in the ON position and the OFF position.
- D. View the switch status on the electronic service tool.
- E. If the switch status indicates “Not Installed”, then the switch parameter has not been programmed.

Expected Result:

The status screen should indicate “ON” if the switch is turned ON. The status screen should indicate “OFF” if the switch is OFF.

Results:

- **Yes** – The switch is operating normally. Continue troubleshooting if the original condition is not resolved. **STOP**.
- **No** – The ECM is not reading the switch status change. Proceed to Test Step 3.

Test Step 3. Check the Switch Circuit for the ECM.

Illustration 142
Connector for Breakout T

g00682375

- A. Turn the ignition key switch to the OFF position.
- B. Install a breakout T to the ECM vehicle harness connector J1/P1.
- C. Fabricate a jumper wire 100 mm (4 inch) long. Crimp a Deutsch pin to both ends of the wire.
- D. Insert the jumper wire into the suspected terminal of the breakout T. Connect the other end of the jumper wire to terminal 5 in the breakout T. Terminal 5 is AP sensor/switch common.
- E. Connect the electronic service tool to the cab data link connector.
- F. Turn the ignition key switch to the ON position.

- G. Alternately remove the jumper wire and then insert the jumper wire from terminal 5. At the same time, monitor the status screen on the electronic service tool.

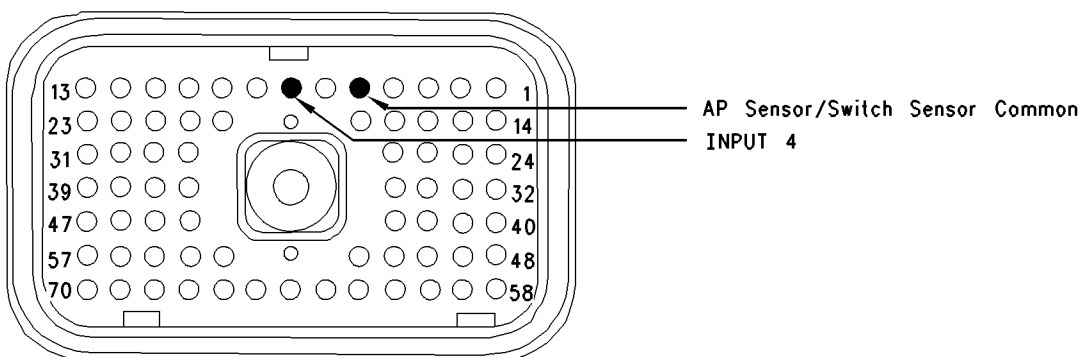
Expected Result:

The switch status changes to “ON” with the jumper wire in place. The switch status changes to “OFF” when the jumper wire is removed.

Results:

- **Yes** – The ECM is functioning properly at this time. Proceed to Test Step 4.
- **No** – The ECM is not functioning properly.

Repair: Perform the following repair:

1. Temporarily connect a test ECM.
2. Remove all jumpers and replace all connectors.
3. Recheck the system for active diagnostic codes.
4. Repeat the test step.
5. If the problem is resolved with the test ECM, reconnect the suspect ECM.
6. If the problem returns with the suspect ECM, replace the ECM.
7. Verify that the repair eliminates the problem.

STOP.

Test Step 4. Insert a Jumper Wire at the Switch.

- A. Turn the ignition key switch to the OFF position.
- B. Reconnect the ECM vehicle harness connector J1/P1.
- C. Fabricate a jumper wire 100 mm (4 inch) long. Crimp a Deutsch pin to each end of the wire.
- D. Insert the jumper wire between the two switch terminals.
- E. Turn the ignition key switch to the ON position.
- F. Alternately remove the jumper wire and then insert the jumper wire at the switch terminals. At the same time, watch the status screen on the electronic service tool.

Expected Result:

The switch status changes to "ON" with the jumper wire in place. The switch status changes to "OFF" when the jumper wire is removed.

Results:

- Yes

Repair: Replace the switch.

Verify that the repair eliminates the problem.

STOP.

- No – There is a problem in the wire harness between the switch and the ECM. Proceed to Test Step 5.

Test Step 5. Insert a Jumper Wire at the Bulkhead Connector.

- A. Turn the ignition key switch to the OFF position.
- B. Fabricate a jumper wire 100 mm (4 inch) long. Crimp a Deutsch pin to each end of the wire.
- C. Locate the suspect switch socket in the engine side of the ECM bulkhead connector.
- D. Insert the wire jumper pin between the switch socket and the sensor common connection. Install the jumper wire on the engine side of the ECM bulkhead connector.
- E. Turn the ignition key switch to the ON position.
- F. Alternately connect and then disconnect the jumper wire. At the same time, monitor the status screen on the electronic service tool.

Expected Result:

The switch status changes from "ON" with the jumper wire in place. The switch status changes to "OFF" when the jumper wire is removed.

Results:

- Yes – The problem is in the vehicle wiring between the bulkhead connector and the switch. Inspect the vehicle wiring and then repair the vehicle wiring. Otherwise, send the vehicle to the OEM dealer for repair. Verify that the original condition is resolved. **STOP.**
- No – The problem is in the vehicle wiring between the bulkhead connector and the ECM. Inspect the vehicle wiring and then repair the vehicle wiring. Otherwise, send the vehicle to the OEM dealer for repair. Verify that the original condition is resolved. **STOP.**

i01604768

Neutral Switch Circuit - Test

SMCS Code: 1900-081-ZS

System Operation Description:

Use this procedure under the following situation:

Use this procedure to determine if the neutral switch is preventing normal operation of cruise control, fast idle, idle set speed, or PTO operation:

The following switch circuits can also prevent the correct operation of the cruise control, fast idle, idle set speed or PTO operation:

- Service brake pedal position (switch 1)
- Service brake pedal position (switch 2)
- Neutral switch
- Cruise control set/resume switch
- Cruise control on/off switch
- PTO on/off switch
- cruise control pause switch

The switches are described in the respective circuit tests in Troubleshooting.

All of the following Customer Programmable Parameters can affect cruise control, fast idle, idle set speed, and PTO operation:

- “Low Cruise Control Speed Set Limit”
- “High Cruise Control Speed Set Limit”
- “Idle Vehicle Speed Limit”
- “Fast Idle RPM #1”
- “Fast Idle RPM #2”
- “Cruise/Idle/PTO Switch Configuration”
- “Idle/PTO Bump rpm”
- “Idle/PTO rpm Ramp Rate”
- “PTO Vehicle Speed Limit”
- “Cruise Pause Switch”

The vehicle speed calibration can also affect the Cruise Control, the Idle Set Speed, and the PTO if the vehicle speed calibration is incorrectly programmed. Refer to Troubleshooting, “Customer Specified Parameters”.

Automatic Transmission Neutral Switch

The automatic transmission neutral switch is required when the “Transmission Style” parameter is programmed to “Automatic Option 3”, “Automatic Option 4”, “AT/MT/HT Option 3”, or “AT/MT/HT Option 4”. This switch is used to indicate when the automatic transmission is in neutral.

The automatic transmission neutral switch is an open circuit when the transmission is in gear. Shifting the transmission to the neutral position should close the circuit, which connects the input to the battery voltage. Many other switches in the system connect the input to ground when the circuit is closed.

This switch may not be connected to an input on the ECM. The parameter “Transmission Neutral Switch” determines the input to the ECM. If the parameter is programmed to J1/P1:62 a switch must be connected to terminal 62. If the parameter is programmed to “J1939”, the switch position will be transmitted to the ECM over the J1939 data link. If a problem is suspected with the J1939 data link, refer to Troubleshooting, “Powertrain Data Link Circuit - Test”.

The following background information is related to this procedure:

The kickout switch refers to the switch that is used to exit the cruise control, the fast idle, the PTO, or the idle set speed.

The operation of the Caterpillar electronic engine cruise control is similar to the operation of the cruise controls that are installed in automobiles. The operation of fast idle, idle, and PTO are similar to the operation of cruise except that the idle and the PTO govern engine rpm instead of vehicle speed.

Note: Idle in this procedure is an engine idle rpm above the programmed low idle rpm. Idle is set by using the cruise control on/off switch and the set/resume switch. Refer to Troubleshooting, “PTO Switch Circuit - Test” for additional information regarding the programmable options for the Dedicated PTO.

Note: Fast idle in this procedure is an engine idle rpm above the programmed low idle rpm. Fast idle is set by using a dedicated fast idle switch.

Cruise Control On/Off Switch

This switch must be ON before cruise control or controlled idle can be activated. This switch is ON when the switch is closed. When the switch is closed the following terminals are connected:

- ECM connector J1/P1 terminal 59 (cruise control on/off switch)
- Terminal 5 (AP sensor/switch sensor common)

Note: If the vehicle is programmed to use the “Dedicated PTO”, the PTO on/off switch overrides the cruise control on/off switch. The PTO on/off switch overrides the cruise control on/off switch when the vehicle speed is within the range of the “PTO Vehicle Speed Limit” that is programmed.

Set/Resume Switch

With the cruise control on/off switch in the ON position and the vehicle speed within the range of the programmed “Low Cruise Control Speed Set Limit” and the “High Cruise Control Speed Set Limit”, momentarily pressing the set switch will activate cruise control, and the ECM will maintain the current speed.

After a speed has been set and the speed is then disengaged by using the brake, the clutch, the cruise control pause switch, or the on/off switch, the ECM will seek the previous set speed when the resume switch is toggled. This assumes that the vehicle speed is above the “Low Cruise Control Speed Set Limit” for cruise control or the vehicle speed is below the “Idle/PTO Vehicle Speed Limit” for the idle and the PTO.

After a speed has been set, pressing and holding the set/resume switch in position will cause the engine to establish a new set speed. The system’s reaction depends on the programming of the “Cruise/Idle/PTO Switch Configuration”.

When the set/resume switch is momentarily pressed, the cruise set point will change one mph. The rate of change is dependent on the programmed “Idle/PTO Bump rpm” when the engine is setting on idle speed.

Cruise Control Pause Switch

The cruise control pause switch is not a switch that is wired to an input. The switch position is broadcast over a J1939 data link. The parameter “Cruise Pause Switch” must be programmed to use a cruise control pause switch. After a speed has been set and the speed is then disengaged by using the cruise control pause switch, the ECM will seek the previous set speed when the resume switch is toggled. This assumes that the vehicle speed is above the “Low Cruise Control Speed Set Limit” for cruise control or the vehicle speed is below the “Idle/PTO Vehicle Speed Limit” for the idle and the PTO.

Kickout Switches

The brake pedal position switches, the neutral switch, the cruise control pause switch, and the clutch pedal position switch are used in the cruise control mode, the PTO mode, the fast idle mode, and the idle mode to discontinue cruise operation, PTO operation, fast idle operation, or idle operation. The capability to override the idle shutdown timer is determined by the “Allow Idle Shutdown Override” parameter setting. The “Allow Idle Shutdown Override” is a Customer Parameter.

Usage of Transmission Style Switches

The “Transmission Style” parameter determines the switches that will be used. The following switches can be used with being dependent on the parameter setting:

- clutch pedal position
- neutral
- service brake pedal position (switch 1)
- service brake pedal position (switch 2)

Refer to Table 174 for additional information.

Table 174

Setting For Transmission Style Parameter	Switch Usage.			
	Service Brake Switch 1	Service Brake Switch 2	Clutch	Neutral
“Manual Option 1”	X		X	
“Manual Option 2”	X	X	X	
“Automatic Option 1”	X			
“Automatic Option 2”	X	X		
“Automatic Option 3”	X	X		X
“Automatic Option 4”	X			X
“AT/MT/HT Option 1”	X			
“AT/MT/HT Option 2”	X	X		
“AT/MT/HT Option 3”	X	X		X
“AT/MT/HT Option 4”	X			X
“Universal Option”	X		X	X

If the “Transmission Style” parameter is programmed to one of the following options, the input for the clutch pedal position switch is not used:

- “Automatic Options 1”
- “Automatic Option 2”
- “Automatic Option 3”

- “Automatic Option 4”
- “AT/MT/HT Option 1”
- “AT/MT/HT Option 2”
- “AT/MT/HT Option 3”
- “AT/MT/HT Option 4”

A Service Brake Pedal Position (Switch 1) is required for all configurations. The Service Brake Pedal Position (Switch 1) connects to the ECM through connector P1 terminal 45. The Service Brake Pedal Position (Switch 2) connects to the ECM through connector P1 terminal 64. The Clutch Pedal Position Switch connects to the ECM through connector P1 terminal 22. The neutral switch connects to the ECM through connector P1 terminal 62.

Some engines that were built before JULY 1999 may have a Basic ECM. The Basic ECM was used only on General Motors chassis. Other chassis used engines that were built with a Full Feature ECM. Basic ECM software does not have the parameter for “Transmission Style”. For these systems, a jumper wire must be installed between the clutch switch input and the sensor common when an automatic transmission is installed. When the jumper wire is installed, the “Clutch Switch” status will always indicate “OFF”. Engines that were built after JULY 1999 use only one type of ECM that can be configured for “Basic” or “Full Feature” operation. A new parameter was added in order to provide this flexibility. The “Truck Manufacturer” parameter was added in order to allow the configuration of the “GM Basic” operation or the “Other Full Feature” operation. This parameter is programmed at Caterpillar when the engine is built. The parameter for “Transmission Style” is not available for engines that have software that is dated prior to SEP00 and the parameter for “Truck Manufacturer” is programmed to “GM”. SEP00 and newer engines that are programmed to “GM” use the “Transmission Style” parameter. The factory default for the “GM” setting is the “Universal” option. The “Universal” option provides identical features as the “Basic” system that is described above. If the “Transmission Style” parameter is programmed to the “Universal” option, a jumper wire must be installed between the clutch switch input and the sensor common when an automatic transmission is installed. Otherwise, the “Transmission Style” parameter can be programmed to match the specific arrangement of the vehicle.

If the problem is with undetermined Cruise/Idle/PTO kickouts use the following procedure:

Operate the vehicle in Cruise/Idle/PTO mode.

After the kickout, review the “ET Status” parameter. The “ET Kickout Status” parameter indicates the cause. This must be performed before the ignition key switch is turned OFF. It is important to remember that the parameter will only indicate the last kickout since the ECM has been powered by the ignition key switch.

The following Kickout Status parameters are available:

- “Cruise Kickout”
- “Idle Kickout”
- “PTO Kickout”
- “Fast Idle Kickout”

This parameter is blank when the ECM is first powered up. If this parameter is blank, “No Occurrence” is indicated. This parameter remains blank until the ECM detects the use of the Cruise/Idle/PTO Mode. Also, this parameter remains blank until the ECM detects the disengagement of the Cruise/Idle/PTO Mode. Refer to Tables 175, 176 and 177 in order to interpret the status screen kickout status parameter.

Table 175

Cruise Control Kickout Status Table		
ET	Meaning or Possible Cause	Troubleshooting
“Vehicle Speed >=Limit”	Intermittent vehicle speed signal or lost vehicle speed signal.	Refer to Troubleshooting, “Vehicle Speed Circuit - Test”.
“Switch Turned Off”	The cruise/idle on/off switch is turned off or the switch circuit has an open circuit condition.	Refer to Troubleshooting, “Cruise Control Switch Circuit - Test”.
“Cruise Control PAUSE Switch”	The cruise control pause switch is depressed or there is an illegal message on the J1939 data link.	Refer to Troubleshooting, “Powertrain Data Link Circuit - Test”.
“Brake Pedal Depressed”	The service brake pedal is depressed or the service brake switch circuit has an open circuit condition.	Refer to Troubleshooting, “Service Brake Pedal Position (Switch 1) Circuit - Test”.
“Clutch Pedal Depressed”	The clutch pedal is depressed or the clutch pedal switch circuit has an open circuit condition. Also, the switch could be incorrectly adjusted.	Refer to Troubleshooting, “Clutch Pedal Position Circuit - Test”.
“Neutral”	The transmission is not in gear or the transmission switch circuit has a short circuit condition.	Proceed with the test procedure.
“Bad Vehicle Speed”	Vehicle speed signal is erratic or intermittent.	Refer to Troubleshooting, “Vehicle Speed Circuit - Test” if a problem with the signal exists.
“PTO Switch On”	The PTO on/off switch is turned on or the circuit for the PTO on/off switch has a short circuit condition.	Refer to Troubleshooting, “PTO Switch Circuit - Test”.
Set Switch Timeout	The set/resume switch was held in the SET position for more than 15 seconds (Basic) or there is a short circuit in the switch circuit.	Cruise control cannot be set until the cruise control on/off switch is turned to the OFF position and then turned back to the ON position. If the circuit for the set switch is suspected, proceed with this test procedure.
Resume Switch Timeout	The set/resume switch was held in the SET position for more than 15 seconds (Basic) or there is a short circuit in the switch circuit.	Cruise control cannot be set until the cruise control on/off switch is turned to the OFF position and then turned back to the ON position. If the circuit for the resume switch is suspected, proceed with this test procedure.
“No Occurrence” or “Not Kicked Out”	Cruise control has not been enabled since the ECM has been powered up.	Drive the vehicle in cruise in order to create the problem again.

Table 176

Idle Kickout Status Table		
ET	Meaning or Possible Cause	Troubleshooting
“No Engine Speed”	Intermittent engine speed signal or lost engine speed signal.	Refer to Troubleshooting, “Engine Speed/Timing Circuit - Test”.
“Switch Turned Off”	The Cruise/Idle On/Off switch is turned OFF or the switch circuit has an open circuit condition.	Refer to Troubleshooting, “Cruise Control Switch Circuit - Test”.
“Cruise Control PAUSE Switch”	The cruise control pause switch is depressed or there is an illegal message on the J1939 data link.	Refer to Troubleshooting, “Powertrain Data Link Circuit - Test”.
“Brake Pedal Depressed”	The service brake pedal is depressed or the service brake switch circuit has an open circuit condition.	Refer to Troubleshooting, “Service Brake Pedal Position (Switch 1) Circuit - Test”.
“Clutch Pedal Depressed”	The clutch pedal is depressed or the clutch pedal switch circuit has an open circuit condition. Also, the switch could be incorrectly adjusted.	Refer to Troubleshooting, “Clutch Pedal Position Switch Circuit - Test”.
“Vehicle Speed ≥ Limit”	The vehicle speed has exceeded the Idle Vehicle Speed Limit or the vehicle speed signal is erratic or intermittent.	Refer to Troubleshooting, “Vehicle Speed Circuit - Test” if a problem with the signal exists.
“Neutral”	The transmission is not in neutral or the transmission neutral switch circuit has an open circuit condition.	Proceed with the test procedure.
“PTO Switch On”	The PTO On/Off switch is turned ON or the PTO On/Off switch circuit has a short circuit condition.	Refer to Troubleshooting, “PTO Switch Circuit - Test”.
“No Occurrence”	Idle set speed has not been enabled since the ECM has been powered up.	Operate the vehicle in the Idle mode in order to create the problem again.

Table 177

Fast Idle Kickout Status Table		
ET	Meaning or Possible Cause	Troubleshooting
“No Engine Speed”	Intermittent engine speed signal or lost engine speed signal.	Refer to Troubleshooting, “Engine Speed/Timing Circuit - Test”.
“Switch Turned Off”	The Fast Idle On/Off switch is turned OFF or the switch circuit has an open circuit condition.	Refer to Troubleshooting, “Cruise Control Switch Circuit - Test”.
“Cruise Control PAUSE Switch”	The cruise control pause switch is depressed or there is an illegal message on the J1939 data link.	Refer to Troubleshooting, “Powertrain Data Link Circuit - Test”.
“Brake Pedal Depressed”	The service brake pedal is depressed or the service brake switch circuit has an open circuit condition.	Refer to Troubleshooting, “Service Brake Pedal Position (Switch 1) Circuit - Test”.
“Clutch Pedal Depressed”	The clutch pedal is depressed or the clutch pedal switch circuit has an open circuit condition. Also, the switch could be incorrectly adjusted.	Refer to Troubleshooting, “Clutch Pedal Position Switch Circuit - Test”.
“Vehicle Speed \geq Limit”	The vehicle speed has exceeded the Idle Vehicle Speed Limit or the vehicle speed signal is erratic or intermittent.	Refer to Troubleshooting, “Vehicle Speed Circuit - Test” if a problem with the signal exists.
“Neutral”	The transmission is not in neutral or the transmission neutral switch circuit has an open circuit condition.	Proceed with the test procedure.
“No Occurrence”	Fast Idle set speed has not been exited since the ECM has been powered up.	Operate the vehicle in the Idle mode in order to create the problem again.

Table 178

Table For The PTO Kickout Status Screen On ET		
ET	Meaning or Possible Cause	Troubleshooting
No Engine Speed	Intermittent engine speed signal or lost engine speed signal.	Refer to Troubleshooting, "Speed/Timing Circuit - Test".
Switch Turned Off	The PTO On/Off switch is turned OFF or the switch circuit has an open circuit condition.	Refer to Troubleshooting, "Cruise Control Switch Circuit - Test".
"Cruise Control PAUSE Switch"	The cruise control pause switch is depressed or there is an illegal message on the J1939 data link.	Refer to Troubleshooting, "Powertrain Data Link Circuit - Test".
"Brake Pedal Depressed"	The service brake pedal is depressed or the service brake switch circuit has an open circuit condition.	Refer to Troubleshooting, "Service Brake Pedal Position Switch 1 Circuit - Test".
"Clutch Pedal Depressed"	The clutch pedal is depressed or the clutch pedal switch circuit has an open circuit condition. Also, the switch could be incorrectly adjusted.	Refer to Troubleshooting, "Clutch Pedal Position Switch Circuit - Test".
Vehicle Speed ≥ Limit	The vehicle speed has exceeded the PTO Vehicle Speed Limit or the vehicle speed signal is erratic or intermittent.	Refer to Troubleshooting, "Vehicle Speed Circuit - Test" if a problem with the signal exists.
Neutral	The transmission is not in neutral or the transmission neutral switch circuit has an open circuit condition.	Proceed with the test procedure.
"No Occurrence" or "Not Kicked Out"	The PTO has not been enabled since the ECM has been powered up.	Operate the vehicle in the PTO mode in order to create the problem again.

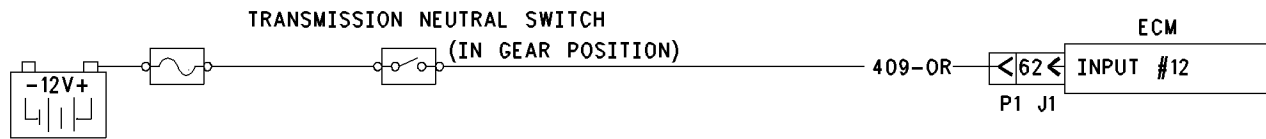

Illustration 143

g00646460

Schematic for transmission neutral switch

Test Step 1. Determine the Type of Problem.

- A. Connect ET to the cab data link connector.
- B. Turn the ignition key switch to the ON position.
- C. If the vehicle will not allow setting a Cruise speed, an Idle speed or a PTO speed, check the following Customer Parameters:

Cruise Control Parameters

- "Low Cruise Control Speed Set Limit"
- "High Cruise Control Speed Set Limit"

Idle Parameters

- "Fast Idle RPM #1"

- "Fast Idle RPM #2"
- "Idle Vehicle Speed Limit"
- "Idle RPM Limit"
- "Top Engine Limit" (TEL)

PTO Parameters

- "PTO Configuration"
- "PTO Vehicle Speed Limit"

- D. Ensure that the vehicle is not experiencing a problem due to one of these parameters. Refer to Troubleshooting, "Customer Specified Parameters" for a description of the parameters, if necessary.

E. Check the status screen that indicates the last cause of a kickout for one of the following modes:

- Cruise Kickout
- Idle Kickout
- Fast Idle Kickout
- PTO Kickout

Refer to Tables 175, 176, 177, and 178 for the meaning of the ET status screen parameter.

Expected Result:

The problem is due to a parameter setting or the problem is due to a normal kickout.

Results:

- **Yes** – Explain the proper operation of system to the driver. **STOP.**
- **No**

Repair: Refer to Tables 175, 176, 177, and 178 for recommended troubleshooting.

If a problem is still suspected with the neutral switch circuit perform the following procedure:

Proceed to Test Step 2.

Test Step 2. Inspect Electrical Connectors and Wiring.

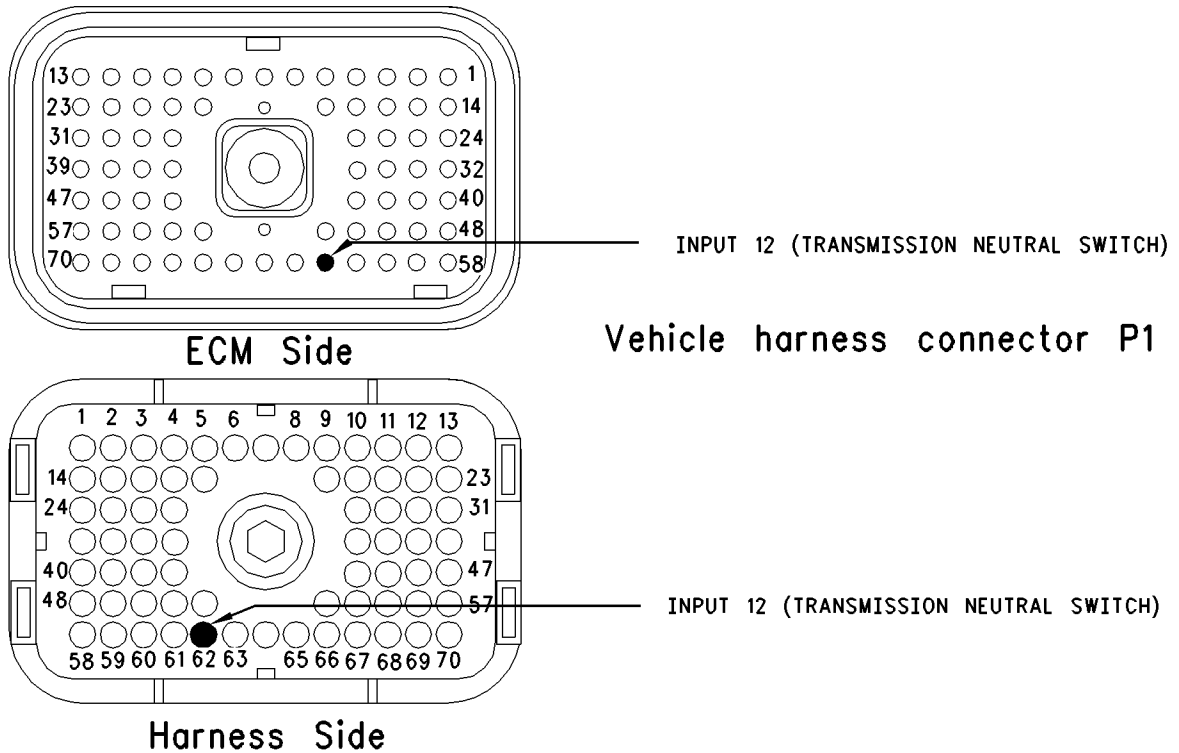

Illustration 144

g00705233

A. Thoroughly inspect ECM vehicle harness connector J1/P1, the firewall bulkhead connector and the terminals for the following switches in the connectors:

- neutral switch (terminal 62)

Refer to Troubleshooting, "Electrical Connectors - Inspect" for details.

B. Perform a 45 N (10 lb) pull test on each of the wires in the ECM connector that are associated with the switches.

Refer to Illustration 144.

C. Check the ECM connector (allen head screw) for the proper torque of 6.0 N·m (55 lb in).

D. Check the harness and wiring for abrasion and pinch points from the sensor to the ECM.

Expected Result:

All connectors, pins and sockets should be completely coupled and/or inserted and the harness and wiring should be free of corrosion, abrasion or pinch points.

Results:

- OK – Proceed to Test Step 3.
- Not OK

Repair: Repair the connectors or wiring and/or replace the connectors or wiring. Ensure that all of the seals are properly in place and ensure that the connectors are completely coupled.

Verify that the repair eliminates the problem.

STOP.

Test Step 3. Check Neutral Switch Status on ET.

Table 179

Neutral Switch Status Table		
Switch Position	Switch Status	Circuit
The transmission is in Neutral.	ON	Closed
The transmission is in Gear.	OFF	Open

- A. Access the ET status screen.
- B. Turn the ignition key switch to the ON position.
- C. Shift the transmission into the Neutral position while the status of the neutral switch is being observed. Also, shift out of Neutral while the status of the neutral switch is being observed.

Note: If the status indicates “Not Installed”, check the programming of the “Transmission Style” Parameter. The “Transmission Style” must be programmed to “Automatic Option 3” or “Automatic Option 4”.

Expected Result:

The switch status changes per the information in Table 179.

Results:

- **Yes** – The switch is operating normally. **STOP**.
- **Intermittent Problem Suspected** – Proceed to Test Step 4.
- **No** – The ECM is not reading the switch status change. Proceed to Test Step 5.

Test Step 4. Operate the Vehicle and Check the Kickout Status Parameter.

- A. For an intermittent Cruise Control Kickout, talk to the driver in order to determine the conditions when the kickout occurs. Topics of examination could be the following examples:
 - specific speed
 - road conditions
 - weather conditions

Take the vehicle for a road test in order to duplicate these conditions and set the cruise control. Operate the vehicle in cruise control until the problem reoccurs.

- B. For an intermittent Idle Kickout, talk to the driver in order to determine the conditions when the kickout occurs. A topic of examination could be the following example:
 - Specific engine rpm

Start the engine. Duplicate these conditions and set the idle rpm. Operate the vehicle in idle until the problem reoccurs.

Note: The status screen will only indicate the last kickout. The status screen will lose this information if the ignition key switch is turned OFF.

- C. Connect ET and check the status screen for the last cause of the kickout. Refer to Tables 175, 176, 177, and 178 for an explanation of the status parameter.
- D. If the status screen is blank, then either there was no kickout of the cruise control, or the power to the ECM was turned OFF before the information could be read. Repeat this test step.

Note: A status screen that is blank indicates “No Occurrence”.

Expected Result:

RESULT 1 The ET Kickout Status displays the following result:

- “Neutral”

RESULT 2 The ET Kickout Status displays the following result:

- “Switch Turned Off”

RESULT 3 The ET Kickout Status displays the following result:

- “Cruise Control PAUSE Switch”

RESULT 4 The ET Kickout Status displays the following result:

- “Brake”

RESULT 5 The ET Kickout Status displays the following result:

- “Vehicle Speed < Limit”
- “Bad Vehicle Speed”
- “Vehicle Speed ≥ Limit”

RESULT 6 The ET Kickout Status displays the following result:

- “PTO Switch ON”

RESULT 7 The ET Kickout Status displays the following result:

- “Clutch”

RESULT 8 The ET Kickout Status displays the following result:

- “No Engine Speed”

RESULT 9 The ET Kickout Status displays the following result:

- “Ser Switch Timeout”
- “Resume Switch Timeout”

Results:

- **Result 1** – Proceed to Test Step 5.
- **Result 2**

Repair: Perform the following diagnostic procedure:

Troubleshooting, “Cruise Control Switch Circuit - Test”

STOP.

- **Result 3**

Repair: Perform the following diagnostic procedure:

Troubleshooting, “Powertrain Data Link Circuit - Test”

STOP.

- **Result 4**

Repair: Perform the following diagnostic procedure:

Troubleshooting, “Service Brake Pedal Position (Switch 1) Circuit - Test”

STOP.

- **Result 5**

Repair: Perform the following diagnostic procedure:

Troubleshooting, “Vehicle Speed Circuit - Test”

STOP.

- **Result 6**

Repair: Perform the following diagnostic procedure:

Troubleshooting, “PTO Switch Circuit - Test”

STOP.

- **Result 7**

Repair: Perform the following diagnostic procedure:

Troubleshooting, “Clutch Pedal Position Switch Circuit - Test”

STOP.

- **Result 8**

Repair: Perform the following diagnostic procedure:

Troubleshooting, “Engine Speed/Timing Circuit - Test”

STOP.

- **Result 9**

Repair: Perform the following diagnostic procedure:

Troubleshooting, “Cruise Control Switch Circuit - Test”.

STOP.

Test Step 5. Check the Switch Circuit for the ECM.

Table 180

Neutral Switch Input Status Table		
Condition of Switch Circuit	Switch Status	Circuit
Terminal 62 is open.	OFF	Open
Terminal 62 connected to +battery.	ON	Closed

- Turn the ignition key switch to the OFF position.
- Fabricate a jumper wire 100 mm (4 inch) long. Crimp a Deutsch pin to both ends of the wires.
- Disconnect vehicle harness connector P1 from the ECM.
- Connect a breakout T to ECM connector J1 and connect P1 to the breakout T.

- E. Install the jumper into terminal 62 (neutral switch) of the breakout T. Connect the other end of the jumper to terminal 52 unswitched +battery of the breakout T.
- F. Turn the ignition key switch to the ON position.
- G. Connect ET to the cab data link connector.
- H. Access the status screen.
- I. While the neutral switch status is being monitored on the status screen slowly remove the jumper from terminal 52 unswitched +battery. Now, slowly insert the jumper into terminal 52 unswitched +battery.

Refer to Table 180.

Expected Result:

The switch status changes per the information in Table 180.

Results:

- **Yes** – The ECM is functioning properly. Proceed to test step 6.
- **No** – The ECM is not functioning properly.

Repair: Perform the following repair:

1. Temporarily connect a test ECM.
2. Remove all jumpers and replace all connectors.
3. Recheck the system for Active diagnostic codes.
4. Repeat the test step.
5. If the problem is resolved with the test ECM, reconnect the suspect ECM.
6. If the problem returns with the suspect ECM, replace the ECM.
7. Verify that the repair eliminates the problem.

STOP.

Test Step 6. Insert a Jumper at the Neutral Switch.

Table 181

Neutral Switch Input Status Table		
Condition of Switch Circuit	Switch Status	Circuit
Neutral switch wires are disconnected.	OFF in gear	Open
Neutral switch wires are connected.	ON in neutral	Shorted

- A. Turn the ignition key switch to the OFF position.
- B. Ensure that ECM vehicle harness connector J1/P1 is connected.
- C. Find the neutral switch in the vehicle.
- D. Disconnect the wires from the neutral switch terminals.
- E. Turn the ignition key switch to the ON position.
- F. Connect ET to the cab data link connector.
- G. Access the status screen.
- H. While the switch status is being monitored on the status screen slowly connect the switch wires and slowly disconnect the switch wires.

Refer to Table 181.

Expected Result:

The switch status changes per the information in Table 181.

Results:

- **Yes** – The switch is not functioning properly.

Repair: Perform the following repair:

Replace the faulty switch.

Verify that the repair eliminates the problem.

STOP.

- **No** – There is a problem in the harness between the switch and the ECM. Proceed to Test Step 7.

Test Step 7. Insert a Jumper at the Bulkhead Connector.

Table 182

Neutral Switch Input Status Table		
Condition of Switch Circuit	Switch Status	Circuit
Bulkhead wires are disconnected.	OFF in gear	Open
Bulkhead wires are connected.	ON in neutral	Shorted

- A.** Turn the ignition key switch to the OFF position.
- B.** Fabricate a jumper wire 100 mm (4 inch) long. Crimp a Deutsch pin to both ends of the wires.
- C.** Find the neutral switch terminal and the +battery connection in the engine side of the bulkhead connector for the vehicle harness.
- D.** Insert the jumper wire between the two terminals in the engine side of the bulkhead connector.
- E.** Turn the ignition key switch to the ON position.
- F.** Connect ET to the cab data link connector.
- G.** Access the status screen.
- H.** While the switch status is being monitored on the status screen alternately remove the jumper wire between the two terminals, and alternately insert the jumper wire between the two terminals.

Refer to Table 182.

Expected Result:

The switch status changes per the information in Table 182.

Results:

- **Yes** – The problem is in the vehicle wiring between the bulkhead connector and the switch.

Repair: Perform the following repair:

Inspect the vehicle wiring and repair the vehicle wiring, as required. If the problem still exists with the wiring, send the vehicle to the OEM dealer.

STOP.

- **No** – The problem is in the vehicle wiring between the bulkhead connector and the ECM.

Repair: Perform the following repair:

Inspect the vehicle wiring and repair the vehicle wiring, as required. If the problem still exists with the wiring, send the vehicle to the OEM dealer.

STOP.

i01858020

Powertrain Data Link Circuit - Test

SMCS Code: 1900-081

System Operation Description:**Use this procedure under the following situation:**

Use this procedure if one of the following diagnostic codes are active:

- 231-02 J1939 Required Data Not Received (58)
- 231-11 J1939 Data Link Fault (58)
- 231-12 J1939 Device Not Responding (58)

Also, use this procedure when ET indicates that the sensor and the ECM are functioning but the engine is not responding to the accelerator pedal position sensor.

The following background information is related to this procedure:**Power train Data Link**

The power train data link is designed to offer electronically controlled Anti-Lock Brakes (ABS), traction control systems, and/or transmission controls. This is accomplished by a momentary reduction of engine rpm and/or engine torque, that is triggered by a signal from an off-engine control module for the ABS, the traction control, or the transmission. An off-engine control module is a control module that is not part of the Caterpillar engine control system.

With OCT01 and newer Personality Modules, information from switches may also be transmitted over the J1939 data link. The following parameters can be programmed to send switch information over the J1939 data link:

- "Cruise Control On/Off Switch"
- "Cruise Control Set/Resume Switch"
- "Cruise Pause Switch"
- "Service Brake Pedal Position Switch #1"
- "Clutch Pedal Position Switch"

- “Fan Override Switch”
- “Exhaust Brake Switch”
- “Diagnostic Enable Switch”
- “A/C High Pressure Switch”
- “A/C Fan Request Switch”

Any combination of the following systems may be installed together on a vehicle:

- Traction Control
- Transmission Control
- ABS
- Switch Information

The required components are installed at the OEM when the vehicle is built.

Powertrain data link sensors, off-engine control modules, and wiring are installed by the vehicle OEM. Questions that relate to the hardware configuration, software, and installation should be referred to the vehicle OEM.

The J1939 refers to the standard for data link communications of the Society of Automotive Engineers Inc.. The ECM has a customer programmable parameter that is called “Powertrain Data Link” which can be programmed to either of the following options:

- J1939
- NONE

Anti-Lock Brake Systems (ABS)

The J1939 data link may be used by an anti-lock brake system (ABS) in order to disable the exhaust brake when the anti-lock brake control determines that the exhaust brake should be disabled. This is usually achieved when the ABS system is active.

Traction Control Systems

Loss of traction is determined by sensors on the vehicle that are mounted near the wheels. These sensors are also used by the ABS system. Typically, a system with traction control includes anti-lock brakes.

Transmission Control

The following characteristics are determined by a vehicle speed sensor in the transmission:

- transmission shift points
- engine rpm
- load

The sensors for power train control provide signals to the vehicle control module of the “Powertrain Data Link”. The vehicle control module of the “Powertrain Data Link” then communicates with the engine ECM. The engine ECM receives a request from the “Powertrain Data Link”. The engine ECM responds by momentarily limiting the following characteristics:

- engine rpm
- torque
- both engine rpm and torque

The presence of an active J1939 data link circuit can be determined by observing the “Powertrain Status” parameter on ET. The ET status screen will display “INSTALLED” if the proper Personality Module is installed on the ECM, and there is no action that is being requested at that time by any of the control modules on the data link.

If an action is being requested by one of the vehicle control modules, the display will indicate the control that is making the request (traction control or transmission control) or a combination of the two (traction control and transmission control). Power train control is also displayed in the upper right hand corner of the display status screen.

J1939 Data Link

SAE J1939 is standard on the Full Feature ECM. The SAE J1939 is not available on the Basic ECM. All 3126B truck engines ((S/N: 8YL)) have the SAE J1939 Data Link.

If the “Truck Manufacturer” parameter is programmed to “GM”, then the “Powertrain Data Link” parameter defaults to “J1939”. If the truck manufacturer is programmed to “OTHER”, then the default is “NONE”. If the data link is required, then the “Powertrain Data Link” parameter must be programmed to “J1939”.

If the “Truck Manufacturer” parameter is programmed to “GM” then the “J1939” Data Link is self-adjusting.

Note: The “Service Engine Soon lamp” will not be illuminated if a message is not broadcast over the data link for a period of 5 hours.

Note: The wiring for the J1939 data link is a shielded twisted pair cable and the wiring is not serviceable. The wiring must be replaced when the wiring is damaged.

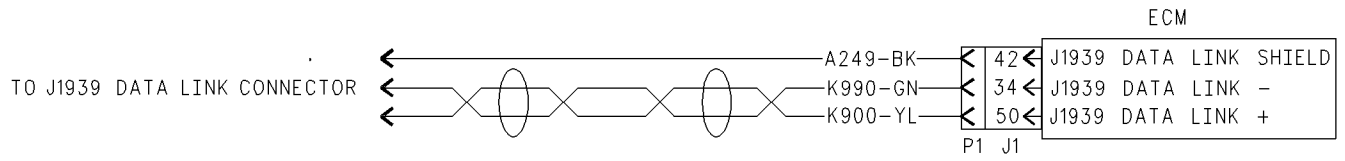
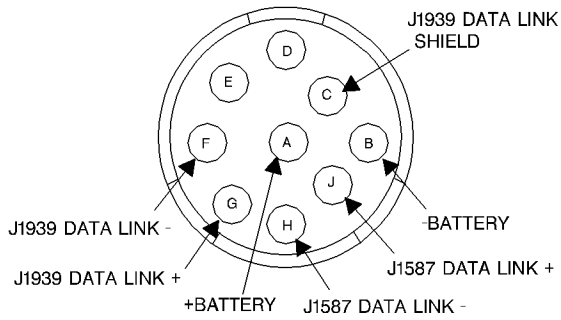
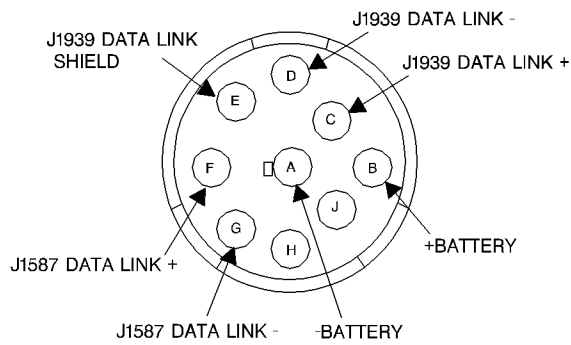

Illustration 145
Schematic for Power train data link

g00830986



DEUTSCH 9-TERMINAL CONNECTOR
Does not require an Adapter Harness for connection to the Service Tool Cable



DEUTSCH J1939/13 OFF-BOARD DIAGNOSTIC CONNECTOR
Requires 157-4829 Adapter Harness for connection to the Service Tool Cable

Illustration 146
ECM pin locations

g00768550

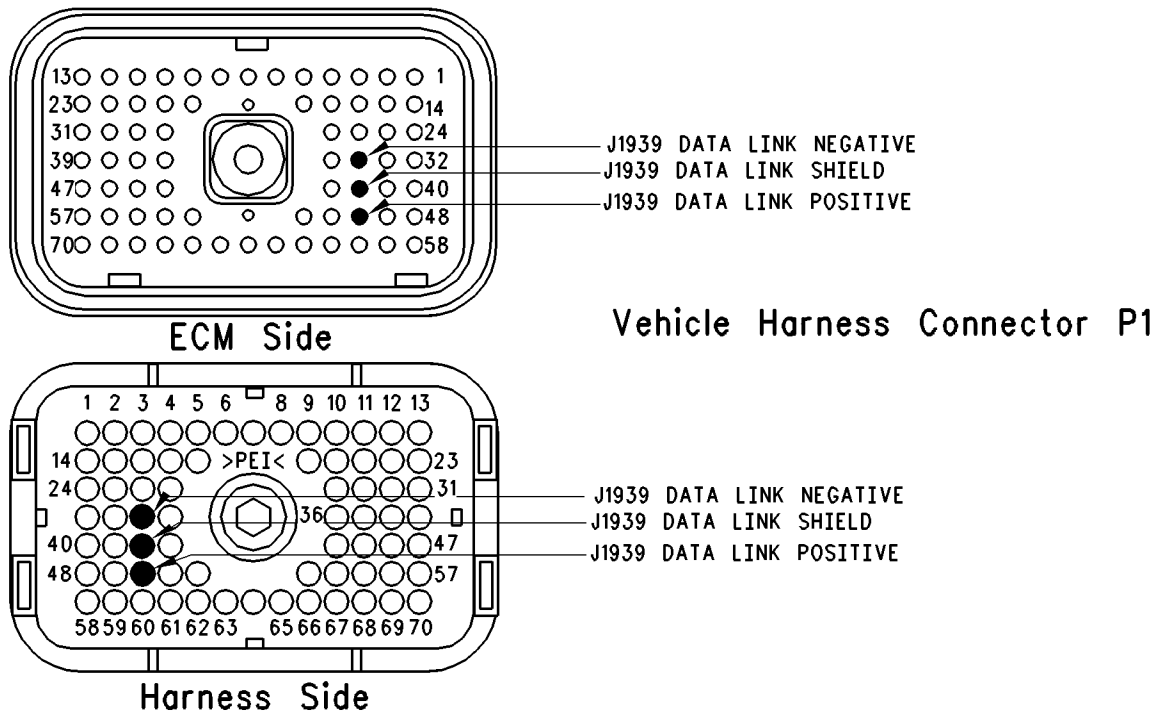

Illustration 147

g00721539

Terminal locations for ECM

Test Step 1. Inspect Electrical Connectors and Wiring.

- A.** Thoroughly inspect ECM vehicle harness connector J1/P1, the firewall bulkhead connector, the connectors for the power train control module, and the connector terminals for the SAE J1939 data link. Refer to Troubleshooting, “Electrical Connectors - Inspect” for details.
- B.** Perform a 45 N (10 lb) pull test on each of the wires in the ECM connector that are associated with the SAE J1939 Data Link.

Refer to Illustration 147.
- C.** Check the ECM connector (allen head screw) for the proper torque of 6.0 N·m (55 lb in).
- D.** Check the harness and wiring for abrasion and pinch points from the data link connectors back to the ECM.

Expected Result:

All connectors, pins and sockets should be completely coupled and/or inserted and the harness and wiring should be free of corrosion, abrasion or pinch points.

Results:

- OK – Proceed to Test Step 2.
- Not OK

Repair: Perform the following repair:

Repair the connectors or wiring and/or replace the connectors or wiring. Ensure that all of the seals are properly in place and ensure that the connectors are completely coupled.

Verify that the repair eliminates the problem.

STOP.

Test Step 2. Connect an Electronic Service Tool and Check for Active Diagnostic Codes.

- A.** Connect the electronic service tool to the cab data link connector.
- B.** Turn the ignition key switch to the ON position.
- C.** Monitor the active diagnostic code screen of the electronic service tool. Check and record active diagnostic codes.

Expected Result:

One of the following diagnostic codes is active:

- 231-11 J1939 Data Link Fault (58)

Note: The “Powertrain Data Link” parameter is a customer parameter that must not be programmed to “J1939”, unless the J1939 Data Link is being used. If J1939 is not connected and the parameter is programmed for J1939 the following active diagnostic code will occur:

- 231-11 J1939 Data Link Fault (58)

Results:

- **Yes 231-11 Active** – Proceed to Test Step 3.
- **No** – Proceed to Test Step 4.

Test Step 3. Use the Special Test on an Electronic Service Tool to Check the Devices on the J1939 Data Link.

- A.** Connect the electronic service tool to the cab data link connector.
- B.** Access the special test “J1939 Receive Communication Status”. The special tests are located under the Diagnostic menu.
- C.** The electronic service tool will display the J1939 sources that have transmitted at least one good message that has been successfully received by the ECM. If the ECM has not received any messages from a source, that source will not be displayed. Examples of devices that can use the J1939 data link include the following switches:
 - Switches that are programmed to “Instrument Cluster”
 - Switches that are programmed to “Body Controller”
 - Switches that are programmed to “Cab Controller”
- D.** The electronic service tool will display the J1939 source in the “Description” column. The “Status” column displays the status of the device.
- E.** If a message is not received from a device, the electronic service tool will display “Not Receiving”.

- F.** The status screen on the electronic service tool can be set to display the status of a device that is not working. The status screen will display “No Comm” if a message is not received from the device.

Expected Result:

The electronic service tool displays the devices that are used on the vehicle and the ECM is receiving messages from the devices.

Results:

- **Yes** – The ECM is receiving messages from the devices that are installed on the vehicle. **STOP.**
- **No** – The ECM is not receiving messages from the devices that are installed on the vehicle.

Repair: The devices that can be programmed to use the J1939 data link can be circuits with two wires or circuits with three wires. Bad connections are the most frequent problem. Repair the connectors or wiring and/or replace the connectors or wiring. Ensure that the connectors are free of corrosion.

STOP.

Test Step 4. Check the Power Train Status Screen on an Electronic Service Tool.

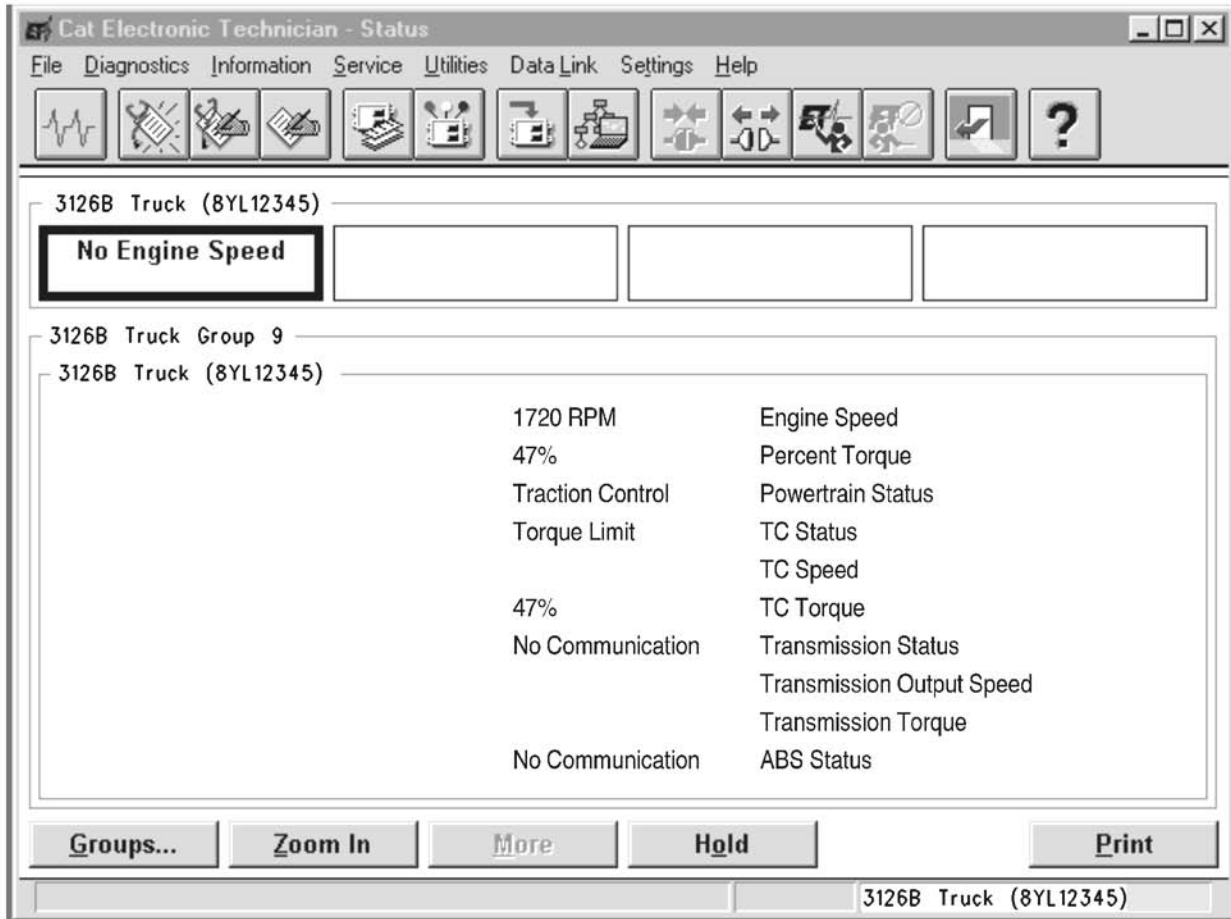

Illustration 148

g00721856

Display screen for the electronic service tool

Table 183

Powertrain Status Parameter Group Definition Table		
Heading On Status Screen	Displayed Message	Definition of Message
Engine Speed		Actual engine rpm of the engine
Percent Torque		Current engine torque during operation that is expressed as a percent of peak torque
Powertrain Status	“Not Installed”, “ABS Control”, “Traction Control”, “Traction and ABS Control”, “Trans Control”, “Trans and ABS Control”, “Trans and Traction Control”, “Trans and Traction and ABS”	Communication of the power train control module

(continued)

(Table 183, contd)

Powertrain Status Parameter Group Definition Table		
Heading On Status Screen	Displayed Message	Definition of Message
TC Status or Transmission Status	"No Communication"	Communication from the vehicle control is not being received by the ECM. One of the following conditions exists: The vehicle does not support this feature. The vehicle control is not currently powered, or the wiring is damaged or disconnected.
	"Not Active"	No requests from the Vehicle Power Train ECU (Electronic Control Unit)
	"Speed Command"	Engine rpm is being controlled by a Vehicle ECU.
	"Torque Command"	Engine torque is being controlled by a Vehicle ECU.
	"Speed and Torque Limit"	Engine rpm and torque is being determined by a Vehicle ECU.
	"Torque Limit"	The Torque limit is being determined by a Vehicle ECU.
	"Speed Limit"	The rpm limit is being determined by a Vehicle ECU.
TC Speed		The TC Speed is the desired engine rpm setpoint or the engine rpm limit that is being requested by the vehicle's Traction Control ECU.
TC Torque		The TC Torque is the desired percent of torque or the desired percent of torque limit that is being requested by the Vehicle's Traction Control ECU.
Transmission Output Speed		The Transmission Output Speed is the desired engine rpm setpoint or the engine rpm limit that is being requested by the Vehicle's Traction Control ECU.
Transmission Torque		The Transmission Torque is the desired percent of torque or the percent of torque limit that is being requested by the Vehicle's Traction Control ECU.

(continued)

(Table 183, contd)

Powertrain Status Parameter Group Definition Table		
Heading On Status Screen	Displayed Message	Definition of Message
ABS Status	“No Communication”	The ECM is not receiving communication from the vehicle’s ABS/Traction Control System. One of the following conditions exists: The vehicle does not support this feature. The vehicle’s ABS/Traction Control System is not currently powered. The wiring is damaged or disconnected.
	“Not Active”	There are no requests from the ABS Control .
	“Disable Retarder”	The control for the ABS system requests the operation of the engine retarder to stop.

- A.** Connect the electronic service tool to the cab data link connector.
- B.** While the vehicle is being driven by someone else, monitor the electronic service tool. Use the following procedure:
 - a.** Access the status screen. Select the “Powertrain Status” screen. The “Powertrain Status” screen relates to the J1939 data link.
 - b.** While the vehicle is being operated, monitor the “Powertrain Status” Screen.

Refer to Table 183 for an explanation of the parameters that are displayed in the “Powertrain Status” screen of the electronic service tool.

Note: Transmission shifts and/or a momentary loss of traction should trigger the electronic service tool display and the appropriate action by the ECM when the correct sensors, controls and wiring are installed on the vehicle.

Expected Result:

The electronic service tool status screen indicates that the ECM is responding to a power train control.

Note: Some power train control modules have test modes that are available by activating diagnostic switches. Ensure that the Caterpillar ECM is not reacting to a test by the power train control module if the problem is related to power train control operation and you believe that the system should not be active.

Results:

- **Yes** – If the response is abnormal, send the vehicle to the OEM dealer for repairs. **STOP.**
- **No**

Repair: Perform the following diagnostic procedure:

Troubleshooting, “Troubleshooting without a Diagnostic Code”

STOP.

i01619414

PTO Engine Shutdown Switch Circuit - Test

SMCS Code: 1165-038-ZS; 1408-081

System Operation Description:

Use this procedure under the following situation:

Use this procedure to determine if the circuit for the PTO Engine Shutdown Switch is operating correctly.

The following background information is related to this procedure:

An input is available to the ECM for connecting a switch to shut down the engine while the engine is operating in PTO mode. To use this feature, the parameter “PTO Configuration” must be programmed to “Cab Switches”, “Remote Switches”, or “Remote Throttle”. The following conditions must also be met in order to use this feature.

- “PTO Engine Shutdown Switch” must be programmed to “P1/J1:7” or “P1/J1J1:23”.
- The PTO On/Off Switch is in the ON position and the PTO is active.
- PTO Engine Shutdown Switch is in the ON position.
- 186-04 PTO Engine Shutdown Short Circuit is not active.
- The vehicle speed is equal to zero.
- No vehicle speed faults are active.

If the vehicle speed is not equal to zero, or if there are active vehicle speed faults, the engine will go to low idle. The engine will not shut down when the vehicle speed falls to zero. When the PTO Engine Shutdown Switch is pressed, a 186-14 PTO Shutdown Switch Occurance will become active. The code will stay active until the engine shuts down. When the engine shuts down, the code will be logged.

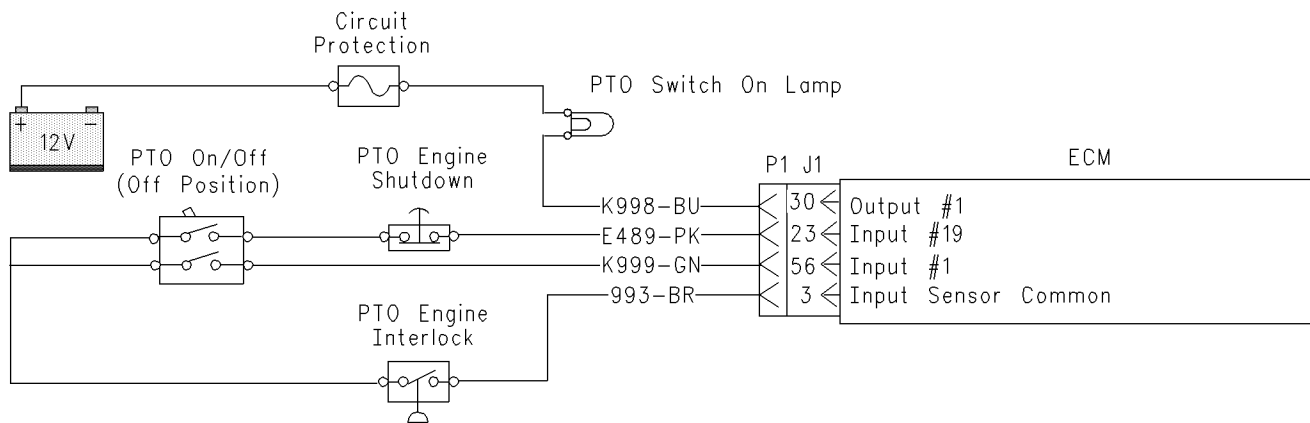

Illustration 149
 Circuit schematic for the PTO Engine Shutdown Switch

g00839184

Note: The PTO engine shutdown switch may also be connected to P1/J1:7 Input # 4. The parameter “PTO Engine Shutdown Switch” must be programmed to “P1/J1:7”.

Test Step 1. Inspect Electrical Connectors and Wiring

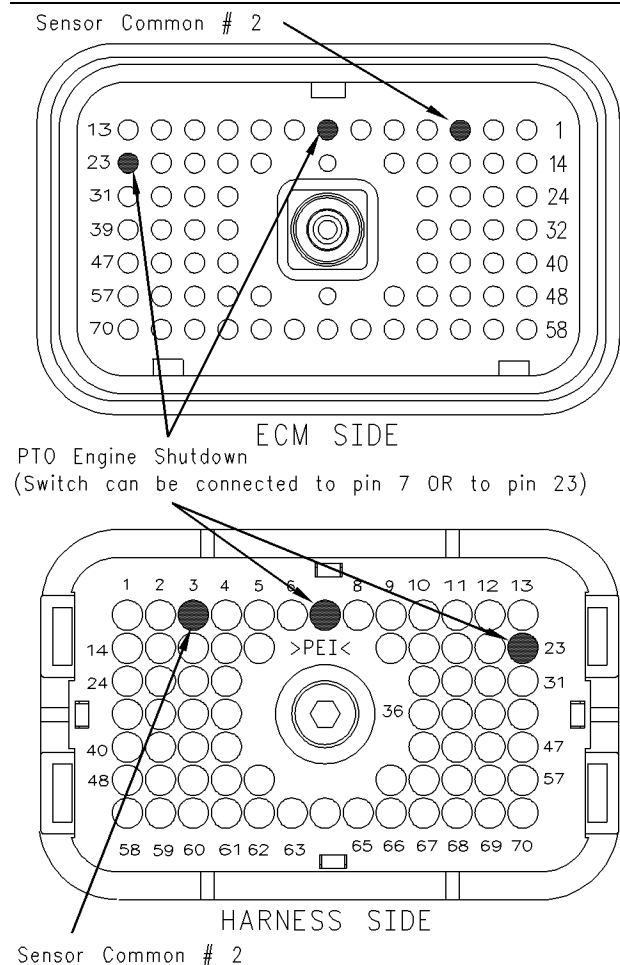

Illustration 150 g00839590
Terminal locations for P1 connector

- A.** Thoroughly inspect the ECM vehicle harness connector J1/P1, the connectors, and the firewall bulkhead connectors. Refer to Troubleshooting, “Electrical Connectors - Inspect” for details.
- B.** Perform a 45 N (10 lb) pull test on each of the wires in the ECM connector that are associated with the suspect switch circuit.
- C.** Check the ECM connector (allen head screw) for the proper torque of 6.0 N·m (55 lb in).
- D.** Check the harness and the wiring for abrasion and for pinch points from the battery to the ECM. Then, check from the ignition key switch to the ECM.

Refer to Illustration 150 for terminal locations for the ECM.

Expected Result:

All connectors, pins, and sockets are completely coupled and/or inserted, and the harness and wiring should be free of corrosion, abrasion or pinch points.

Results:

- **OK** – Proceed to Test Step 2.
- **Not OK** – Repair the wiring and connectors or replace the wiring or the connectors. Ensure that all of the seals are properly connected. Verify that the repair eliminates the problem. **STOP.**

Test Step 2. Check the Switch Status on ET

- A.** Connect Electronic Technician (ET) to the cab data link connector.
- B.** Turn the ignition key switch to the ON position.
- C.** Operate the switch in the ON position and the OFF position.
- D.** View the switch status on ET.
- E.** If the switch status indicates “Not Installed”, the parameter “PTO Engine Shutdown Switch” has not been programmed.

Expected Result:

The status screen should indicate “ON” if the switch is turned ON. The status screen should indicate “OFF” if the switch is OFF.

Results:

- **Yes** – The switch is operating normally. Continue troubleshooting if the original condition is not resolved. **STOP.**
- **No** – The ECM is not reading the change in the status of the switch. Proceed to Test Step 3.

Test Step 3. Check the Switch Circuit for the ECM.

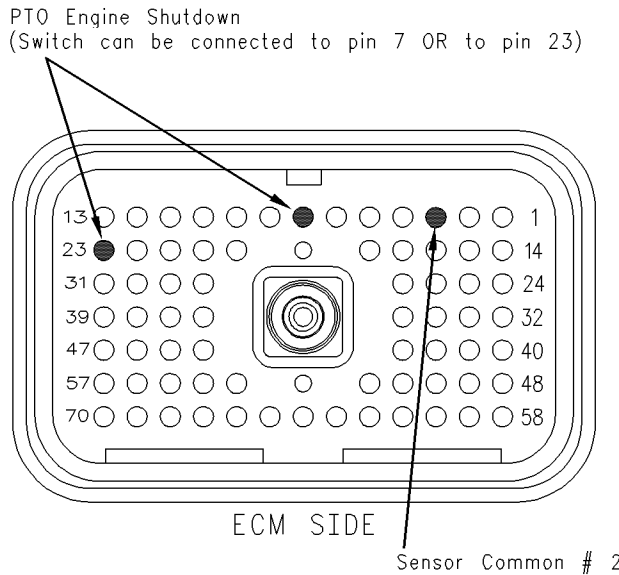

Illustration 151

g00839604

Breakout T

- A. Turn the ignition key switch to the OFF position.
 - B. Install a breakout T to the ECM connector J1/P1.
 - C. Fabricate a jumper wire 100 mm (4 inch) long. Crimp a Deutsch pin to both ends of the wire.
 - D. Insert the jumper wire into terminal 7 or terminal 23 of the breakout T. Connect the other end of the jumper wire to terminal 3 in the breakout T. Terminal 3 is sensor common.
 - E. Connect ET to the cab data link connector.
 - F. Turn the ignition key switch to the ON position.
 - G. Alternately remove the jumper wire and then insert the jumper wire from terminal 5. At the same time, monitor the status screen on ET.
1. Temporarily connect a test ECM.
 2. Remove all jumpers and replace all connectors.
 3. Recheck the system for active diagnostic codes.
 4. Repeat the test step.
 5. If the problem is resolved with the test ECM, reconnect the suspect ECM.
 6. If the problem returns with the suspect ECM, replace the ECM.
 7. Verify that the repair eliminates the problem.
- STOP.

Expected Result:

The status of the switch changes to "ON" with the jumper wire in place. The status of the switch changes to "OFF" when the jumper wire is removed.

Results:

- **Yes** – The ECM is functioning properly at this time. Proceed to Test Step 4.
- **No** – The ECM is not functioning properly.

Repair: Perform the following repair:

Test Step 4. Insert a Jumper Wire at the Switch.

- A. Turn the ignition key switch to the OFF position.
- B. Reconnect the ECM vehicle harness connector J1/P1.
- C. Fabricate a jumper wire 100 mm (4 inch) long. Crimp a Deutsch pin to both ends of the wire.
- D. Insert the jumper wire between the two switch terminals.
- E. Turn the ignition key switch to the ON position.

- F. Alternately remove the jumper wire and then insert the jumper wire at the switch terminals. At the same time, watch the status screen on ET.

Expected Result:

The status of the switch changes to "ON" with the jumper wire in place. The status of the switch changes to "OFF" when the jumper wire is removed.

Results:

- Yes

Repair: Replace the switch.

Verify that the repair eliminates the problem.

STOP.

- No – There is a problem in the wire harness between the switch and the ECM. Proceed to Test Step 5.

Test Step 5. Insert a Jumper Wire at the Bulkhead Connector.

- A. Turn the ignition key switch to the OFF position.
- B. Fabricate a jumper wire 100 mm (4 inch) long. Crimp a Deutsch pin to both ends of the wire.
- C. Locate the suspect terminal on the engine side of the bulkhead connector.
- D. Insert the wire jumper pin between the switch socket and the sensor common connection. Install the jumper wire on the engine side of the bulkhead connector.
- E. Turn the ignition key switch to the ON position.
- F. Alternately connect and then disconnect the jumper wire. At the same time, monitor the status screen on ET.

Expected Result:

The status of the switch changes from "ON" with the jumper wire in place. The status of the switch changes to "OFF" when the jumper wire is removed.

Results:

- Yes – The problem is in the vehicle wiring between the bulkhead connector and the switch. Inspect the vehicle wiring and then repair the vehicle wiring. Otherwise, send the vehicle to the OEM dealer for repair. Verify that the original condition is resolved. STOP.

- No – The problem is in the vehicle wiring between the bulkhead connector and the ECM. Inspect the vehicle wiring and then repair the vehicle wiring. Otherwise, send the vehicle to the OEM dealer for repair. Verify that the original condition is resolved. STOP.

i01674427

PTO Shutdown Timer - Test

SMCS Code: 1900-038

System Operation Description:

Use this procedure under the following situation:

Use this procedure to determine if the PTO Shutdown is operating correctly.

The following background information is related to this procedure:

PTO Shutdown Timer

A programmable parameter for the PTO Shutdown Timer is provided. This timer will shut down the engine when all of the following conditions are met:

- The PTO shutdown time that is programmed has expired.
- The ECM is programmed to use "Dedicated PTO" parameters.
- The PTO on/off switch is ON and the ECM is in the dedicated PTO mode.
- The engine is not in the Cold Mode.

During the last 90 seconds of the PTO Shutdown Timer, the check engine lamp will begin flashing. If the vehicle is equipped with a PTO switch on lamp, the PTO switch on lamp will begin flashing during the last 90 seconds.

If the PTO shutdown timer is activated and the timer stops the engine, the following event code will be generated.

- 71-14 PTO Shutdown Timer Occurrence (47)

Note: Fuel rates are not monitored while the PTO shutdown timer is active. Shutdown will occur regardless of load. Unlike the idle shutdown timer, the PTO shutdown timer cannot be overridden by using the clutch pedal or the brake pedal.

Test Step 1. Verify Activation of the PTO Shutdown Timer

- A. Connect Caterpillar Electronic Technician (Cat ET) to the cab data link connector.

- B.** Access the Customer Parameters on Cat ET.
Access the following display screens in order:
- “Service”
 - “Configuration”
- a.** Record the programmed PTO shutdown time.
The PTO shutdown Time must be between 3 and 1440 minutes. If the PTO shutdown time is programmed to 0, the timer is disabled.
- C.** Start the engine. Allow the engine to warm up until the coolant temperature is 38 °C (100 °F). Allow the engine to operate at the programmed low idle and turn off any unnecessary accessory devices.
- D.** Ensure that all unnecessary loads are turned off.
- E.** Use the following procedure in order to check the operation of the PTO shutdown:
- a.** Park the vehicle.
 - b.** Ensure that the PTO configuration is programmed to “Cab Switches”, “Remote Switches” or “Remote Throttle”.
 - c.** Ensure that the status of the PTO on/off switch is on.
 - d.** Observe the status of the “PTO Shutdown”.

Expected Result:

Result 1 The status of the parameter for “PTO Shutdown” indicates “COUNTING”.

Result 2 The ECM is not reading the proper conditions for activation of the timer.

Results:

- **Result 1** – The ECM is reading the proper conditions for the activation of the PTO shutdown timer. Proceed to Test Step 2.
- **Result 2** – Proceed to Test Step 3.

Test Step 2. Use Cat ET to Verify the Driver Alert Function of the PTO Shutdown

- A.** Connect Cat ET to the cab data link connector.
- B.** Use the following procedure in order to activate the PTO shutdown timer:
- a.** Access the “Customer Parameters” on Cat ET.
Access the following display screens in order:

- “Service”
- “Configuration”

- b.** Record the programmed PTO shutdown time.
The PTO shutdown time must be between 3 and 1440 minutes. If the PTO shutdown time is programmed to 0, the timer is disabled.
- c.** Reprogram the PTO shutdown time to 3 minutes for this test.

- C.** Observe the following items during the 90 second period before the programmed shutdown time:
- Check engine lamp
 - Status of the PTO shutdown timer
 - PTO switch on lamp

During the 90 second period before the scheduled shutdown, the status should change from “COUNTING” to “DRIVER ALERT” and the check engine lamp and the PTO switch on lamp should flash rapidly.

Note: A PTO switch on lamp is an optional feature and the PTO switch on lamp may not be installed.

- D.** Reprogram the PTO shutdown timer to the value that was recorded earlier for this test.

Expected Result:

Result 1 The driver alert function of the PTO shutdown operates in the manner that is described above.

Result 2 The PTO switch on lamp did not flash.

Result 3 The check engine lamp did not flash.

Results:

- **Result 1** – The PTO shutdown timer is operating properly. Clear all diagnostic codes. **STOP.**
- **Result 2** – The PTO switch on lamp did not flash during the driver alert.

Repair: Perform the following diagnostic procedure: Troubleshooting, “PTO Switch ON Lamp Circuit - Test”

STOP.

- **Result 3** – The check engine lamp did not flash during the driver alert.

Repair: Perform the following diagnostic procedure:

Troubleshooting, "Check Engine Lamp Circuit - Test"

STOP.

Test Step 3. Check the State of the Related Conditions when the Vehicle is Parked

- A.** Check the state of the following related conditions when the vehicle is parked:
- Ensure that the vehicle speed is 0 km/h (0 mph) on Cat ET or the dash display.
 - Ensure that the engine is not in cold mode.

Note: The Cat ET status screen will indicate if the cold mode is active.

- Ensure that the PTO on/off switch is on.

Expected Result:

Result 1 Vehicle speed is not indicated as 0 km/h (0 mph).

Result 2 The Cat ET status screen indicates that the engine is in the cold mode.

Result 3 The PTO on/off switch is not on.

Results:

- Result 1** – Continue by testing the vehicle speed circuit.

Repair: Perform the following diagnostic procedure: Troubleshooting, "Vehicle Speed Circuit - Test"

STOP.

- Result 2** – The engine must not be in cold mode operation while this test procedure is being performed. Allow the engine to run until the coolant temperature exceeds 38 °C (100 °F). Troubleshoot and repair any related conditions. STOP.

- Result 3** – Continue by testing the circuit for the PTO on/off switch.

Repair: Perform the following diagnostic procedure: Troubleshooting, "PTO Switch Circuit - Test"

STOP.

i01611141

PTO Switch Circuit - Test

SMCS Code: 1165-081-ZS

System Operation Description:

Use this procedure under the following situation:

Use this procedure to determine that the vehicle wiring and the ECM are functioning properly for the features of Dedicated PTO.

The following background information is related to this procedure:

INPUT #1

The input 1 is used for the circuit for the PTO on/off switch when the PTO Configuration is programmed to "Cab Switches", "Remote Switches", or "Remote Throttle".

When the PTO on/off switch is on, the ECM will be in Dedicated PTO mode.

When the ECM is in the Dedicated PTO mode the PTO Top Engine Limit (TEL) is activated. The engine may proceed directly to the PTO engine rpm set speed if the parameter is programmed. If a PTO switch on lamp is connected to the output 1, the PTO switch on lamp will turn on whenever the PTO on/off circuit is on.

If the problem is with undetermined PTO kickouts, use the following procedure:

Operate the vehicle in PTO mode.

After the kickout, review the status parameter on ET. The status parameter indicates the cause of the kickout. This must be performed before the ignition key switch is turned off. It is important to remember that the parameter will only indicate the last kickout since the ECM has been powered by the ignition key switch.

This parameter is blank when the ECM is first powered up. If this parameter is blank, "No Occurrence" or "Not Kicked Out" is indicated. This parameter remains blank until the ECM detects the use of the PTO mode. Also, this parameter remains blank until the ECM detects the disengagement of PTO mode. Refer to Table 184 in order to interpret the status parameter.

The following kickout status parameter is available:

- PTO kickout

PTO interlocks may also be connected in series with the PTO on/off switch. The interlocks are intended to prevent the PTO on/off circuit from activating unless certain conditions are met.

INPUT 2

The input 2 is used for the PTO set/rpm increase switch when the “PTO Configuration” is programmed to “Remote Switches” or “Remote Throttle”.

INPUT 3

The input 3 is used for the PTO resume/rpm decrease switch when the “PTO Configuration” is programmed to “Remote Switches” or “Remote Throttle”.

The PTO Configuration Is Set To Cab Switches.

When the “PTO Configuration” is programmed to “Cab Switches” and the PTO on/off switch is on, the following circuits can be used to interrupt a set rpm:

- Cruise control set/resume switch
- Service brake pedal position switch 1
- Service brake pedal position switch 2
- Clutch pedal position switch
- Neutral switch
- Cruise Control Pause Switch

When the “PTO Configuration” is programmed to “Cab Switches” and the PTO on/off switch is on, the cab accelerator pedal position sensor can be limited to one of the following settings by using the “PTO Cab Throttle RPM Limit” parameter:

- Low idle
- PTO Top Engine Limit
- Top engine limit

The “PTO Configuration” Is Set To Remote Switches or Remote Throttle.

When the “PTO Configuration” is programmed to “Remote Switches” or “Remote Throttle” and the PTO on/off switch is on, the following circuits are ignored:

- Service brake pedal position switch 1
- Service brake pedal position switch 2
- Clutch pedal position switch

- Neutral switch
- Cab accelerator pedal position sensor
- Cab cruise control set/resume switch

A remote accelerator pedal position sensor is connected to the input 8 when the “PTO Configuration” is programmed to “Remote Throttle”.

Note: The wiring for your particular application may be slightly different. The circuits for the sensor common are used interchangeably by the OEM of the vehicle. The following circuits are common within the ECM:

- The “Input Sensor Common 1” is terminal 18.
- The “Input Sensor Common 2” is terminal 3.
- The “AP Sensor/Switch Sensor Common” is terminal 5.

Table 184

Table For The PTO Kickout Status Screen On ET		
ET	Meaning or Possible Cause	Troubleshooting
No Engine Speed	Intermittent engine speed signal or lost engine speed signal.	Refer to Troubleshooting, "Speed/Timing Circuit - Test".
Switch Turned Off	The PTO On/Off switch is turned OFF or the switch circuit has an open circuit condition.	Proceed with the test procedure.
"Cruise Control PAUSE Switch"	The cruise pause switch is depressed or there is an illegal message on the J1939 data link.	Refer to Troubleshooting, "Powertrain Data Link Circuit - Test".
"Brake Pedal Depressed"	The service brake pedal is depressed or the service brake switch circuit has an open circuit condition.	Refer to Troubleshooting, "Service Brake Pedal Position Switch 1 Circuit - Test".
"Clutch Pedal Depressed"	The clutch pedal is depressed or the clutch pedal switch circuit has an open circuit condition. Also, the switch could be incorrectly adjusted.	Refer to Troubleshooting, "Clutch Pedal Position Switch Circuit - Test".
Vehicle Speed ≥ Limit	The vehicle speed has exceeded the PTO Vehicle Speed Limit or the vehicle speed signal is erratic or intermittent.	Refer to Troubleshooting, "Vehicle Speed Circuit - Test" if a problem with the signal exists.
Neutral	The transmission is not in neutral or the transmission neutral switch circuit has an open circuit condition.	Refer to Troubleshooting, "Neutral Switch Circuit - Test".
"No Occurrence" or "Not Kicked Out"	The PTO has not been enabled since the ECM has been powered up.	Operate the vehicle in the PTO mode in order to create the problem again.

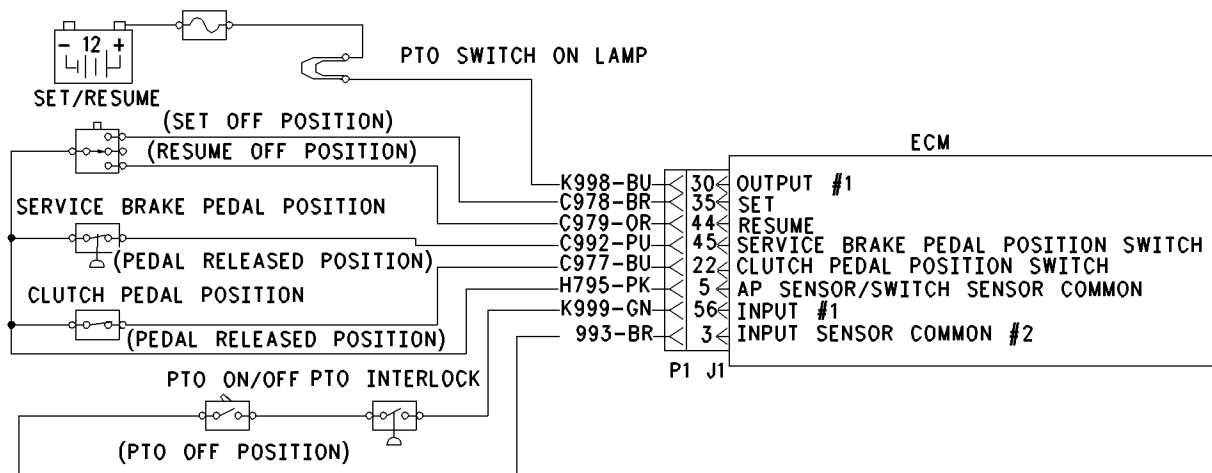

Illustration 152

g00644420

This illustration is for the schematic for "cab switches" for "PTO configuration".

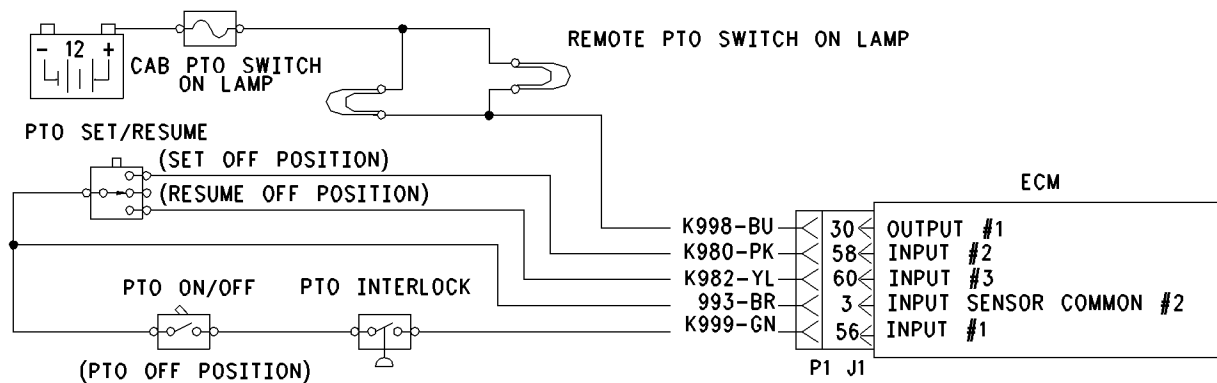

Illustration 153

g00644427

This illustration is for the schematic for "remote switches" for "PTO configuration".

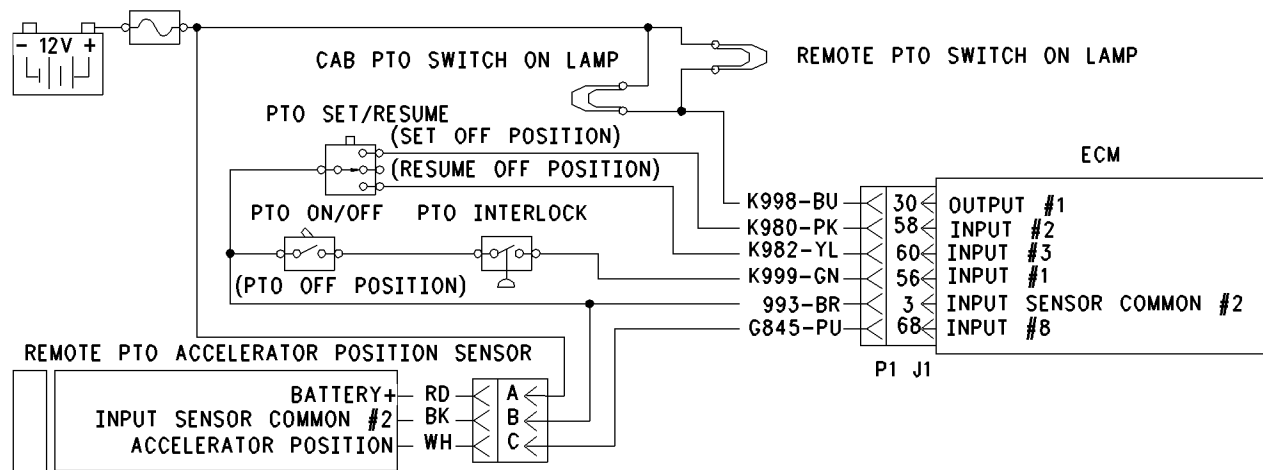

Illustration 154

g00644448

This illustration is for the schematic for "remote throttle" for "PTO configuration".

Test Step 1. Check the Programming of the Dedicated PTO Customer Parameter.

- A. Connect ET to the cab data link connector.
- B. Turn the ignition key switch to the ON position.
- C. Access the Dedicated PTO Customer Parameters on ET. Note the programming of the PTO Configuration Parameter.

Expected Result:

The "PTO Configuration" is programmed to "Cab Switches", "Remote Switches", or "Remote Throttle".

Results:

- Yes – Proceed to Test Step 2.

- **No** – The Dedicated PTO features are not programmed for this engine. If PTO operation is desired, the “PTO Configuration” must be programmed to “Cab Switches”, “Remote Switches”, or “Remote Throttle”. **STOP**.

Test Step 2. Determine the PTO Installation Setup.

- A.** From the programming of the PTO Configuration Parameter, review the truck wiring in order to determine the method of installation of the wiring. Talk to the driver about the use of the PTO.
- B.** Check the cab glove box for any information regarding the installation of the PTO. It is important to understand the location and the function of the PTO Interlocks that are used in the installation.
- C.** Contact the installer of the PTO component, if necessary.
- D.** Determine the schematic that most closely matches the installation. Review the schematics in this procedure for each of the options for the specific “PTO Configuration ”of the truck.
- E.** Record the “PTO Configuration”.

Expected Result:

The requirements for the installation and the application have been reviewed.

Results:

- **OK** – Proceed to Test Step 3.

Test Step 3. Inspect Electrical Connectors and Wiring.

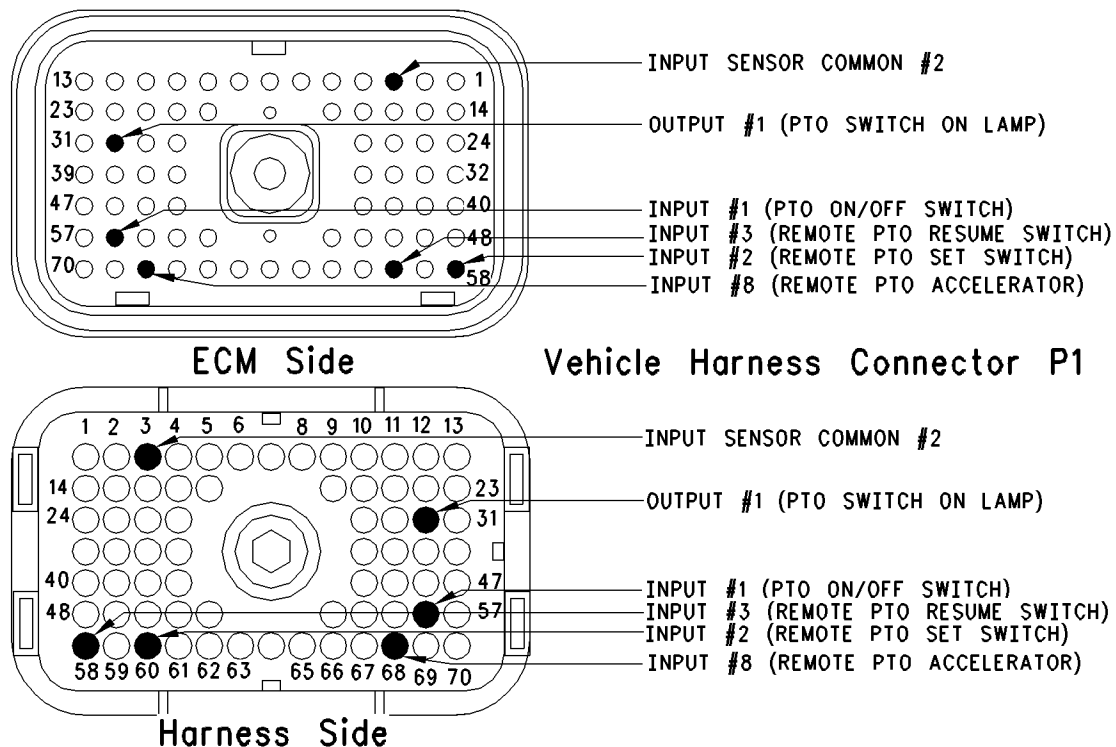

Illustration 155

g00713728

Terminal locations for ECM

A. Thoroughly inspect ECM connector J1/P1, the firewall bulkhead connectors, and any connectors that are used by the PTO.

Refer to Troubleshooting, “Electrical Connectors - Inspect” for details.

B. Perform a 45 N (10 lb) pull test on each of the wires in the ECM connector that are associated with the connections for the PTO. The following connections should be tested if the connections are used:

- terminal 3
- terminal 5
- terminal 30
- terminal 35
- terminal 44
- terminal 56
- terminal 58
- terminal 60

- terminal 68

Refer to Illustration 155.

C. Check the ECM connector (allen head screw) for the proper torque of 6.0 n·m (55 lb in).

D. Check the harness and wiring for abrasion and pinch points from the sensor to the ECM.

Expected Result:

All connectors, pins and sockets should be completely coupled and/or inserted and the harness and wiring should be free of corrosion, abrasion or pinch points.

Results:

- OK – Proceed to Test Step 4.
- Not OK

Repair: Perform the following diagnostic procedure:

Repair the connectors or wiring and/or replace the connectors or wiring. Ensure that all of the seals are properly in place and ensure that the connectors are completely coupled.

Verify that the repair eliminates the problem.

STOP.

Test Step 4. Check the PTO On/Off Switch Circuit with ET.

- A. Turn the ignition key switch to the ON position.
- B. For the input 1 (PTO on/off switch), access the ET status screens that display the following status parameters:
 - “PTO Config”
 - “PTO ON/OFF Switch”
- C. Verify that each of the PTO interlocks are set. Then, while the ET status screen is being monitored turn on the PTO on/off switch and turn off the PTO on/off switch.

An example of a PTO interlock would be a parking brake that is intended to allow PTO engine control under specific conditions.

Expected Result:

Result 1 The status of the PTO on/off switch on ET changes from “OFF” to “ON” when the PTO on/off switch is turned to the OFF position and the ON position, but the set/resume switch is not operating correctly.

Result 2 The status of the PTO on/off switch on ET changes from “OFF” to “ON” when the PTO on/off switch is turned to the OFF position and the ON position. However, the remote accelerator is not operating correctly.

Result 3 The status of the PTO on/off switch on ET does not change from “OFF” to “ON” when the PTO on/off switch is turned to the OFF position and the ON position.

Results:

- **Result 1** – Proceed to Test Step 5.
- **Result 2**

Repair: Perform the following diagnostic procedure: Troubleshooting, “Remote PTO Accelerator Position Sensor Circuit - Test”

STOP.

- **Result 3** – Proceed to Test Step 6.

Test Step 5. Check Status of the Set/Resume Input on ET.

Note: The set/resume input increases the engine rpm and the set/resume input decreases the engine rpm.

- A. Find the PTO set/resume switch. If the “PTO Configuration” is programmed to “Cab Switches”, the cruise control set/resume switch will be used. If the “PTO Configuration” is programmed to “Remote Switches” or “Remote Throttle”, a dedicated PTO set/resume switch will be used.

The “PTO Configuration” is programmed to Cab Switches.

Look at the status for the “Cruise Control Set/Resume Switch” parameter on ET. The parameter is located on the same status screen as the cruise/idle switch.

- B. While the ET status screen for the switch is being monitored, perform the following procedure in order:

- Put the cruise control set/resume switch in the Set position.
- Release the cruise control set/resume switch from the Set position.
- Put the cruise control set/resume switch in the Resume position.
- Release the cruise control set/resume switch from the Resume position.

The “PTO Configuration” is programmed to Remote Switches or Remote Throttle.

View the status parameter on ET for the “Remote PTO Set Switch” and the “Remote PTO Resume Switch”.

- C. While the ET status screen for the switch is being monitored, perform the following procedure in order:

- Put the remote PTO set/resume switch in the Set position.
- Release the remote PTO set/resume switch from the Set position.
- Put the remote PTO set/resume switch in the Resume position.
- Release the remote PTO set/resume switch from the Resume position.

Expected Result:

When the “PTO Configuration” is programmed to “Cab Switches”, the status parameter for the cruise control set/resume switch on ET behaves in the following manner:

- The status of the cruise control set/resume switch will display “OFF” when the set switch is released.
- The status of the cruise control set/resume switch changes from “OFF” to set switch “ON” when the switch is moved to the SET position.
- The status of the cruise control set/resume switch changes from set switch “ON” to resume switch “ON” when the resume switch is moved to the RESUME position.

When the “PTO Configuration” is programmed to “Remote Switches” or “Remote Throttle”, the status parameter for the remote PTO set switch behaves in the following manner:

- The status screen for the remote PTO set switch displays OFF when the remote PTO set switch is released.
- The status of the remote PTO resume switch displays OFF when the remote PTO resume switch is released.
- The status of the remote PTO set switch changes from OFF to set switch ON when the remote PTO set switch is moved to the SET position.
- The status of the remote PTO resume switch changes from OFF to resume switch ON when the remote PTO resume switch is moved to the RESUME position.

Results:

- **Yes** – The set circuit and the resume circuit are functioning correctly. The PTO Inputs are functioning properly. Continue troubleshooting if the original condition is not resolved. **STOP**.
- **No (programmed to “Cab Switches”)** – The “PTO Configuration” is programmed to “Cab Switches”. Proceed to Test Step 7.
- **No (programmed to “Remote Switches” or “Remote Throttle”)** – The “PTO Configuration” is programmed to “Remote Switches” or “Remote Throttle”. Proceed to Test Step 8.

Test Step 6. Check the Status of the PTO On/Off Switch on ET.

Input Sensor Common #2

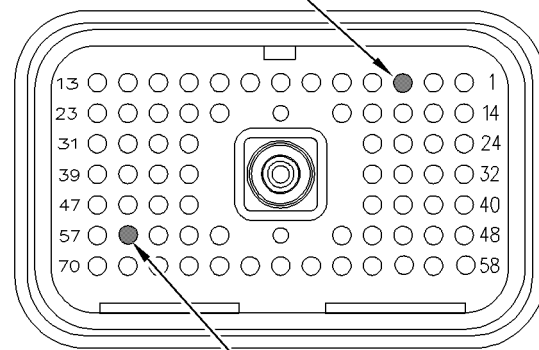

Input #1 (PTO On/Off Switch)

Illustration 156

g00768799

ECM breakout T-connector

- Turn the ignition key switch to the OFF position.
- Fabricate a jumper wire 100 mm (4 inch) long. Crimp a Deutsch pin to both ends of the wire.
- Disconnect vehicle harness connector P1 from the ECM.
- Connect a breakout T to ECM connector J1 and connect P1 to the breakout T.
- Connect ET to the cab data link connector.
- Turn the ignition key switch to the ON position.
- Access the “PTO On/Off Switch” status on ET.
- While the switch status is being observed on ET install the jumper into the breakout T in order to connect terminal 56 (input 1) to terminal 3 (input sensor common #2).

The input 1 is the PTO on/off switch.

Refer to Illustration 156.

Expected Result:

The switch status of the “PTO On/Off Switch” on ET behaves in the following manner:

- The switch status is “OFF” when the jumper is removed.

- The switch status changes from “OFF” to “ON” when the jumper is in place.

Results:

- **Yes** – The input 1 (PTO on/off switch) of the ECM is functioning correctly. The problem is in the switches of the vehicle or the problem is in the wiring of the vehicle.

Repair: Inspect the wiring. Select one of the following options:

- Repair the wiring or replace the wiring.
- Send the vehicle to the OEM dealer for repair.

Verify that the repair eliminates the problem.

STOP.

- **No** – The ECM is not reading the switch status change.

Repair: Perform the following diagnostic procedure:

1. Temporarily connect a test ECM.
2. Ensure that the “PTO Configuration” of the test ECM matches the “PTO Configuration” of the suspect ECM.
3. Remove all jumpers and replace all connectors.
4. Recheck the system for active diagnostic codes.
5. Repeat the test step.
6. If the problem is resolved with the test ECM, reconnect the suspect ECM.
7. If the problem returns with the suspect ECM, replace the ECM.
8. Verify that the repair eliminates the problem.

STOP.

Test Step 7. Check the Status of the Cruise Control Set/Resume Switch on ET.

Illustration 157
ECM breakout T-connector

g00768798

- A. Turn the ignition key switch to the OFF position.
- B. Fabricate a jumper wire 100 mm (4 inch) long. Crimp a Deutsch pin to both ends of the wire.
- C. Disconnect vehicle harness connector P1 from the ECM.
- D. Connect a breakout T to ECM connector J1 and connect P1 to the breakout T.
- E. Connect ET to the cab data link connector.
- F. Turn the ignition key switch to the ON position, while the engine is off.
- G. Access the status of the cruise control set/resume switch on ET.
- H. While the switch status is being observed on ET install the jumper into the breakout T in order to connect terminal 35 (Set) to terminal 5 (AP sensor/switch sensor common). Also, while the switch status is being observed on ET remove the jumper from the breakout T in order to disconnect terminal 35 (Set) from terminal 5 (AP sensor/switch sensor common).
- I. While the switch status is being observed on ET, install the jumper into the breakout T. This connects terminal 44 (resume) to terminal 5 (AP sensor/switch sensor common). Also, while the switch status is being observed on ET, remove the jumper from the breakout T. This will disconnect terminal 44 (resume) from terminal 5 (AP sensor/switch sensor common).

Refer to Illustration 157.

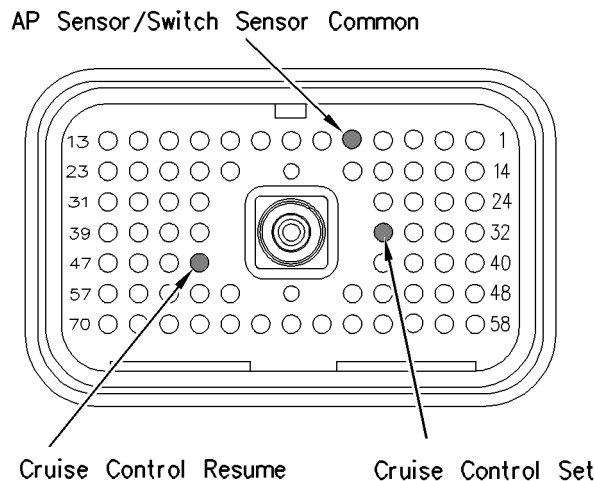
Expected Result:

The switch status of the cruise control set/resume switch on ET behaves in the following manner:

- The switch status of the cruise control set/resume switch is “OFF” when the jumper is removed.
- The switch status of the cruise control set/resume switch changes from “OFF” to set switch “ON” when the jumper is connected from terminal 35 (Set) to terminal 5 (AP sensor/switch sensor common).
- The switch status of the cruise control set/resume switch changes from “OFF” to resume switch “ON” when the jumper is connected from terminal 44 (switch resume terminal) to terminal 5 (AP sensor/switch sensor common).

Results:

- **Yes** – The set input and the resume input of the ECM are functioning correctly. The problem is in the switches of the vehicle or the problem is in the wiring of the vehicle.

Repair: Inspect the wiring. Select one of the following options:

- Repair the wiring or replace the wiring.
- Send the vehicle to the OEM dealer for repair.

Verify that the repair eliminates the problem.

STOP.

- **No** – The ECM is not reading the switch status change.

Repair: Perform the following diagnostic procedure:

1. Temporarily connect a test ECM.
2. Ensure that the “PTO Configuration” of the test ECM matches the “PTO Configuration” of the suspect ECM.
3. Remove all jumpers and replace all connectors.
4. Recheck the system for active diagnostic codes.
5. Repeat the test step.
6. If the problem is resolved with the test ECM, reconnect the suspect ECM.

7. If the problem returns with the suspect ECM, replace the ECM.

8. Verify that the repair eliminates the problem.

STOP.

Test Step 8. Check the Status of the Remote PTO Set Switch and the Remote PTO Resume Switch on ET.

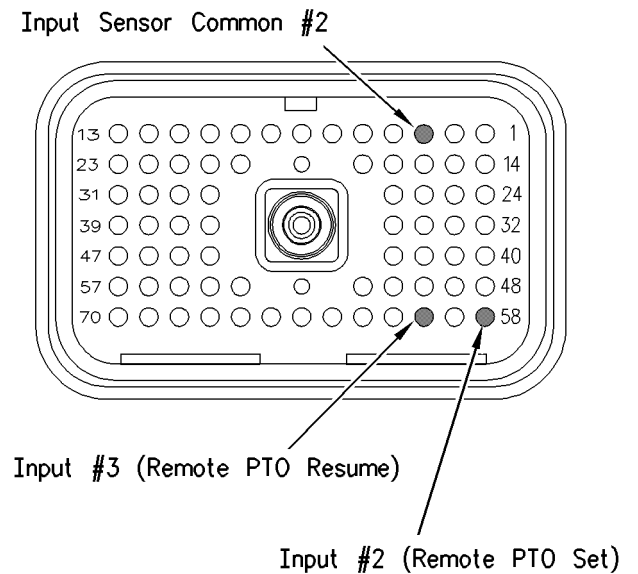

Illustration 158
ECM Breakout T-connector g00768769

- A. Turn the ignition key switch to the OFF position.
- B. Fabricate a jumper wire 100 mm (4 inch) long. Crimp a Deutsch pin to both ends of the wire.
- C. Disconnect vehicle harness connector P1 from the ECM.
- D. Connect a breakout T to ECM connector J1 and connect P1 to the breakout T.
- E. Connect ET to the cab data link connector.
- F. Turn the ignition key switch to the ON position.
- G. Access the Remote PTO Set Switch and Remote PTO Resume Switch status on ET.
- H. While the status of the Remote PTO Set Switch is being observed on ET, install the jumper into the breakout T in order to connect terminal 58 (input 2) to terminal 3 (input sensor common #2). Also, while the switch status is being observed on ET remove the jumper from the breakout T in order to disconnect terminal 58 (input 2) from terminal 3 (input sensor common #2).

- I. While the status of the Remote PTO Resume Switch is being observed on ET, install the jumper into the breakout T in order to connect terminal 60 (input 3) to terminal 3 (input sensor common #2). Also, while the switch status is being observed on ET remove the jumper from the breakout T in order to disconnect terminal 60 (input 3) from terminal 3 (input sensor common #2).

The input 2 is the set switch for the PTO and the input 3 is the resume switch for the PTO.

Refer to Illustration 158.

Expected Result:

The switch status of the Remote PTO Set Switch on ET behaves in the following manner:

- The switch status of the Remote PTO Set Switch is "OFF" when the jumper is removed.
- The switch status of the Remote PTO Set Switch changes from "OFF" to set switch "ON" when the jumper is connected from terminal 58 (input 2) to terminal 3 (input sensor common #2).

The switch status of the Remote PTO Resume Switch on ET behaves in the following manner:

- The switch status of the Remote PTO Resume Switch is "OFF" when the jumper is removed.
- The switch status of the Remote PTO Resume Switch changes from "OFF" to resume switch "ON" when the jumper is connected from terminal 60 (input 3) to terminal 3 (input sensor common #2).

Results:

- **Yes** – The input 2 (Remote PTO Set Switch) and the input 3 (Remote PTO Resume Switch) of the ECM are functioning correctly. The problem is in the switches of the vehicle or the problem is in the wiring of the vehicle.

Repair: Inspect the wiring. Select one of the following options:

- Repair the wiring or replace the wiring.
- Send the vehicle to the OEM dealer for repair.

Verify that the repair eliminates the problem.

STOP.

- **No** – The ECM is not reading the switch status change.

Repair: Perform the following diagnostic procedure:

1. Temporarily connect a test ECM.
2. Ensure that the "PTO Configuration" of the test ECM matches the "PTO Configuration" of the suspect ECM.
3. Remove all jumpers and replace all connectors.
4. Recheck the system for Active diagnostic codes.
5. Repeat the test step.
6. If the problem is resolved with the test ECM, reconnect the suspect ECM.
7. If the problem returns with the suspect ECM, replace the ECM.
8. Verify that the repair eliminates the problem.

STOP.

i01613057

PTO Switch ON Lamp Circuit - Test

SMCS Code: 7431-081

System Operation Description:

Use this procedure under the following situation:

Use the following information in order to determine if the PTO Switch ON Lamp is operating incorrectly.

Terminal 30 (Output 1)

Output 1 can be used as a PTO Switch On Lamp output. If the "PTO Configuration" is programmed to "Cab Switches", "Remote Switches", or "Remote Throttle", the output will turn on the lamp whenever the PTO Switch Circuit is turned on.

Electrical Connection of Lamps

One terminal of the lamp must be connected to battery voltage through the vehicle wiring. The other terminal is connected to the ECM at the vehicle harness connector J1/P1 at terminal 30.

The ECM provides a path to ground in order to turn on the lamp.

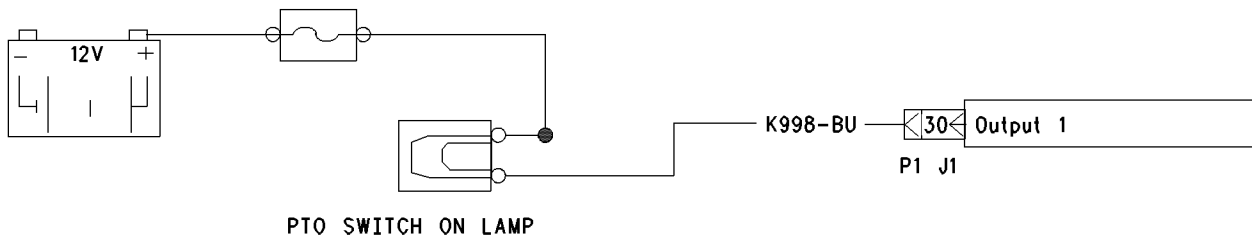

Illustration 159

g00703413

Schematic for PTO Switch ON Lamp

OCT01 Software

If terminal 30 is used for another function, a lamp may be wired to a multiple pole PTO On/Off switch.

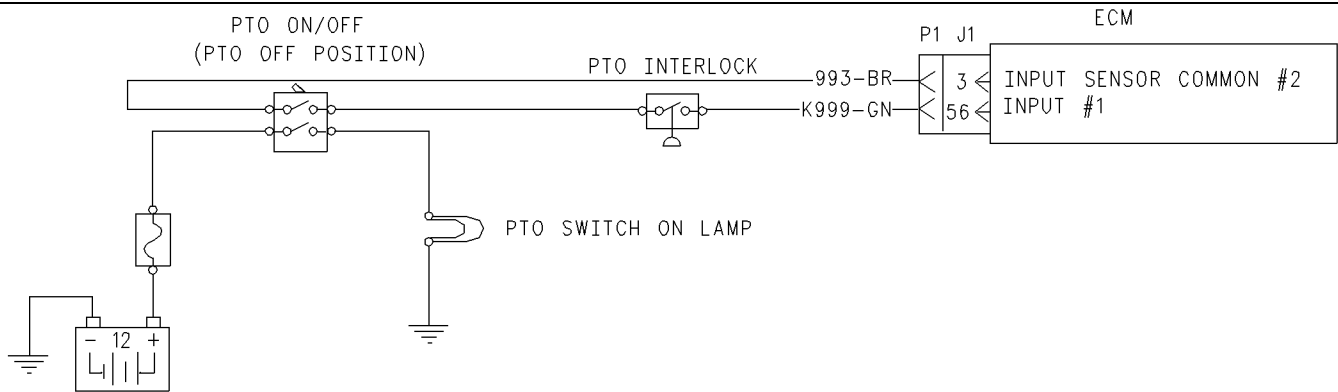

Illustration 160

g00834964

Optional circuit for PTO Switch ON Lamp

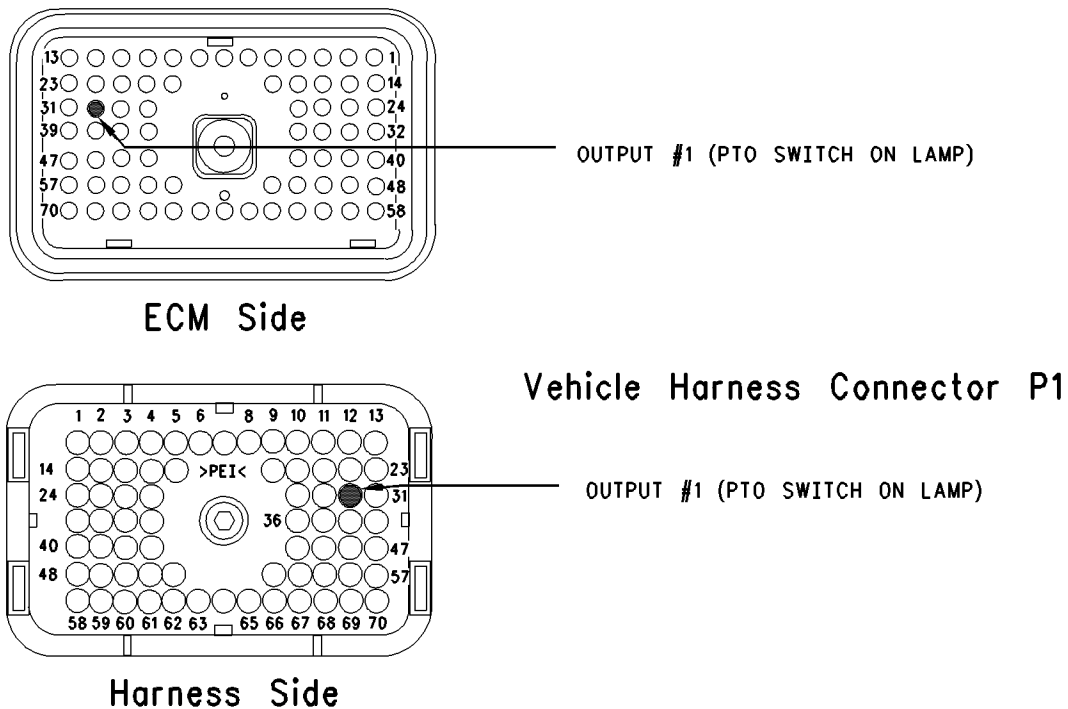

Illustration 161

g00668646

Terminal locations for ECM

Test Step 1. Inspect Electrical Connectors and Wiring.

- A. Thoroughly inspect ECM vehicle harness connector J1/P1, the firewall bulkhead connector, or the PTO Switch ON Lamp. Refer to Troubleshooting, “Electrical Connectors - Inspect” for details.
- B. Perform a 45 N (10 lb) pull test on each of the wires in the ECM Connector that are associated with the PTO Switch ON Lamp.

Refer to Illustration 161.
- C. Check the ECM connector (allen head screw) for the proper torque of 6.0 N·m (55 lb in).
- D. Check the harness and wiring for abrasion and pinch points from the battery to the ECM.

Expected Result:

All connectors, pins and sockets should be completely coupled and/or inserted and the harness and wiring should be free of corrosion, abrasion or pinch points.

Results:

- OK – Proceed to Test Step 2.

- Not OK

Repair: Repair the connectors or wiring and/or replace the connectors or wiring. Ensure that all of the seals are properly in place and ensure that the connectors are completely coupled.

STOP.

Test Step 2. Check for Normal Operation of the PTO Switch ON Lamp.

- A. Use the following procedure for the output 1 (PTO Switch ON Lamp).

Connect ET to the cab data link connector. Access the status screen that displays the “PTO Configuration” and the PTO On/Off Switch. The “PTO Configuration” must indicate “Cab Switches”, “Remote Switches”, or “Remote Throttle”. The “PTO Configuration” is not programmed to turn on the PTO Switch ON Lamp if the “PTO Configuration” parameter is programmed to “OFF”.

While the PTO Switch ON Lamp and the status of PTO On/Off Switch is being monitored on ET, turn the PTO On/Off Switch to the ON position and the OFF position. The PTO Switch ON Lamp should turn on when the PTO On/Off Switch is in the ON position. Also, the PTO Switch ON Lamp should turn off when the PTO On/Off switch is in the OFF position.

Expected Result:

The lamp turns on and the lamp turns off per the above description.

Results:

- Yes – The lamp appears to operating correctly at this time. STOP.
- No – Proceed to Test Step 3.

Test Step 3. Test the PTO Switch ON Lamp Circuit.

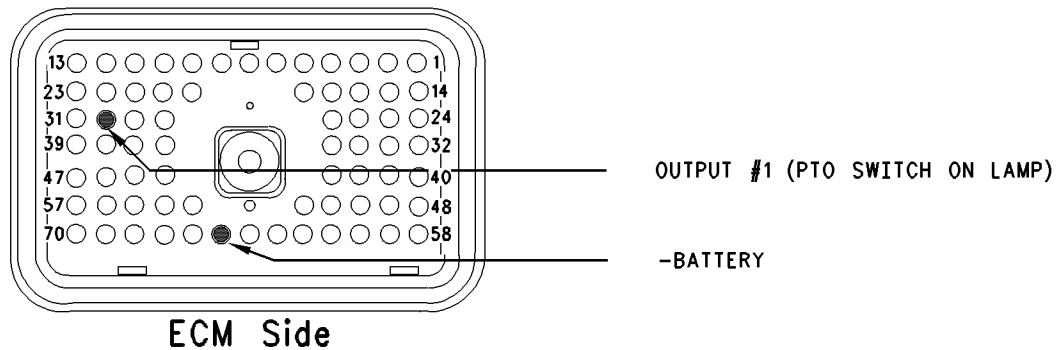

Illustration 162

g00668711

Vehicle harness connector P1

- A. Disconnect ECM vehicle harness connector J1/P1.
- B. Fabricate a jumper wire 100 mm (4 inch) long. Crimp a Deutsch pin to both ends of the wire.
- C. Insert the jumper into terminal 30 of connector P1.
- D. Connect the other end of the jumper wire to terminal 65 (-battery) of connector P1.
- E. Turn the ignition key switch to the ON position.
- F. While the lamp is being watched, insert the jumper wire and remove the jumper wire.

Refer to Illustration 162.

Expected Result:

Result 1 The PTO Switch On Lamp turns on while the jumper is connected to both sockets. Also, the PTO Switch On Lamp turns off when the jumper is removed from one of the sockets.

Result 2 The suspect lamp does not turn on while the jumper is connected to both sockets.

Result 3 The lamp will stay on while the ECM vehicle harness connector is disconnected.

Results:

- **Result 1** – The circuit for the PTO Switch ON Lamp is functioning properly. Proceed to Test Step 4.

- **Result 2** – The lamp did not turn on. The vehicle's lamp circuit is not functioning properly. The lamp is probably burned out or there is a problem in the wiring from the cab to either the ECM or the +Battery connection. Repair the lamp circuit or send the vehicle to the OEM dealer for repairs. **STOP.**

- **Result 3**

Repair: Perform the following diagnostic procedure:

The circuit between the ECM and the lamp is shorted to chassis ground. Repair the circuit or send the vehicle to the OEM dealer for repairs.

STOP.

Test Step 4. Check ECM Operation of the PTO Switch On Lamp.

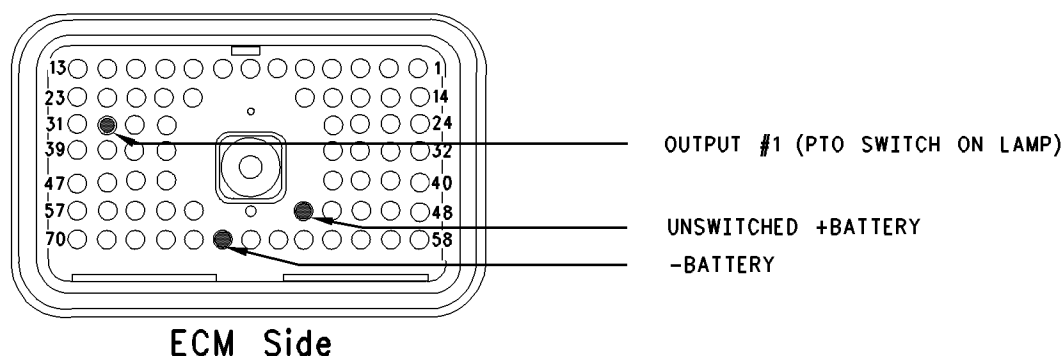

Illustration 163

g00642533

ECM Breakout T-connector

- A.** Disconnect ECM vehicle harness connector J1/P1.
- B.** Insert a breakout T between ECM vehicle harness connector J1 and ECM vehicle harness connector P1.
- C.** Connect one probe of the voltage test lamp to terminal 65 (-battery). Connect the other probe of the voltage test lamp to terminal 52 (unswitched +battery) of the breakout T.
- D.** The test lamp should turn on. If the test lamp does not turn on, either the test lamp is faulty or the wiring to the ECM is faulty. Continue with this step if the lamp turns ON.
- E.** Leave the probe of the test lamp connected to terminal 52 (unswitched +battery).
- F.** Connect the other probe of the test lamp to terminal 30 (Output 1) of the breakout T.
- G.** Connect ET. Access the following display screens in order:
 - "Diagnostics"
 - "Diagnostic Test"
 - "Special Test"
- H.** Activate the special test for the PTO Switch ON Lamp. Observe the voltage test lamp. The lamp should turn on when the test is active. Also, the lamp should turn off when the test is inactive.

Expected Result:

The test lamp turns on and the test lamp turns off per the above description.

Results:

- **Yes** – The ECM is operating correctly. There is a problem in the vehicle wiring or the lamp. **STOP.**

Refer to Illustration 163.

- No

Repair: Temporarily connect a test ECM. Ensure that the “PTO Configuration” of the test ECM matches the “PTO Configuration” of the suspect ECM. Check the ECM operation of the PTO Switch ON Lamp when the test ECM is installed. If the problem is resolved with the test ECM, reconnect the suspect ECM. If the problem returns with the suspect ECM, replace the ECM.

STOP.

i01626696

Remote PTO Accelerator Position Sensor Circuit - Test

SMCS Code: 1913

System Operation Description:

Use this procedure under the following situation:

Use this procedure if any of the following diagnostic codes are indicated:

- 30-08 Invalid PTO Throttle Signal (29)
- 30-13 PTO Throttle Sensor Calibration (29)

Also, use this procedure if the remote accelerator position sensor is suspected of improper operation.

Remote Accelerator Position Sensor

A remote accelerator position sensor may be used for PTO purposes. The remote accelerator position sensor should be connected to the ECM connector J1/P1:68. Before the ECM will respond to the remote accelerator position sensor, the ECM PTO Configuration must be programmed to Remote Throttle, and the PTO On/Off Switch must be in the ON position. Also, Caterpillar offers the following recommendation:

- The remote accelerator position sensor must be powered from the vehicle battery (+12 V).

Therefore, the +12 V version of the accelerator position sensor must be used for the remote accelerator position sensor, and the +8 V version for the accelerator pedal position sensor in the cab.

The ECM will not respond to the remote accelerator position sensor if 253-02 Check Customer or System Parameters (56) is active under some conditions. Refer to Troubleshooting, “ECM Memory - Test” if 253-02 Check Customer or System Parameters (56) is active.

The remote accelerator position sensor is used to provide a throttle position signal to the ECM. Sensor output is a constant frequency signal with a pulse width that varies with the pedal position. This output signal is referred to as either a duty cycle or a pulse width modulated signal (PWM) and this output signal is expressed as a percentage between 3 and 100 percent.

The accelerator position sensor in the cab is attached directly to the accelerator pedal assembly and the sensor requires no adjustment.

The accelerator position sensor will produce a duty cycle of 10 to 22 percent at low idle and 75 to 90 percent when the accelerator pedal is fully depressed. The percent of duty cycle is translated in the ECM into an accelerator pedal position of 3 to 100 percent.

The accelerator position sensor can be replaced separately from the pedal assembly. An incorrectly calibrated pedal assembly can not be adjusted. The entire pedal assembly must be replaced.

If the vehicle is using the ECM dedicated PTO functions, the accelerator position sensor will be ignored while the engine is in PTO mode and the PTO Configuration is programmed to the following setting:

- Remote Throttle

The ECM is in PTO mode if the PTO On/Off Switch is on. This can be checked through the status screen on ET.

The ECM will not respond to the remote accelerator position sensor when both of the following conditions are met:

- The PTO On/Off circuit is switched from the OFF position to the ON position.
- The ECM reads the remote accelerator position sensor above low idle.

This prevents the engine from experiencing unexpected acceleration or sudden acceleration when the PTO On/Off circuit is turned on. The remote accelerator position sensor must return to low idle before the ECM will respond. The ECM must also see a transition from the OFF position to the ON position in the PTO On/Off Switch in order to allow the other PTO speed control functions to operate. If the engine is started with the PTO On/Off Switch in the ON position, the accelerator will respond. The response will occur only if the accelerator pedal is first returned to the low idle position. The other speed control functions will not respond.

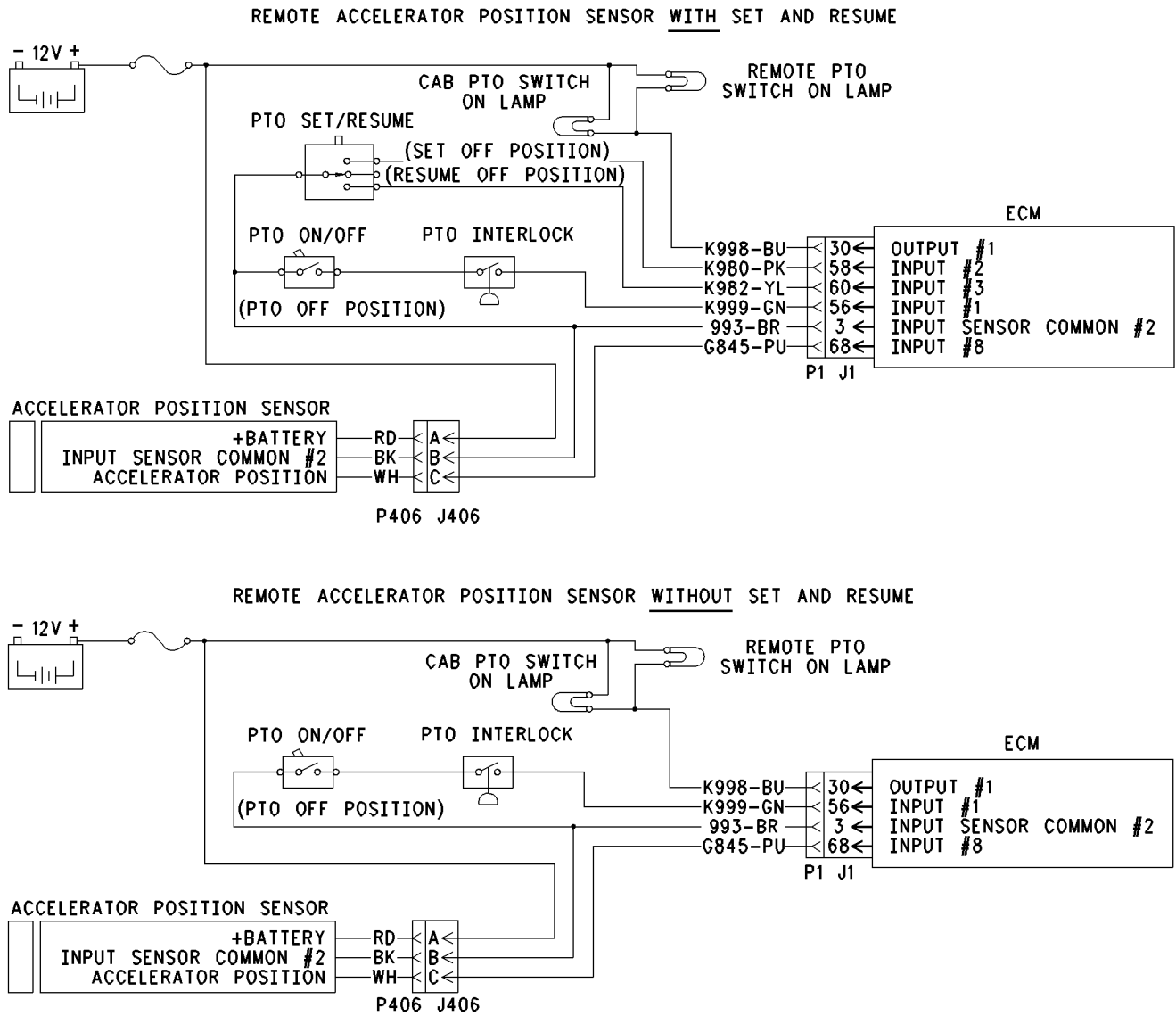

Illustration 164

Schematic for remote accelerator pedal position sensor

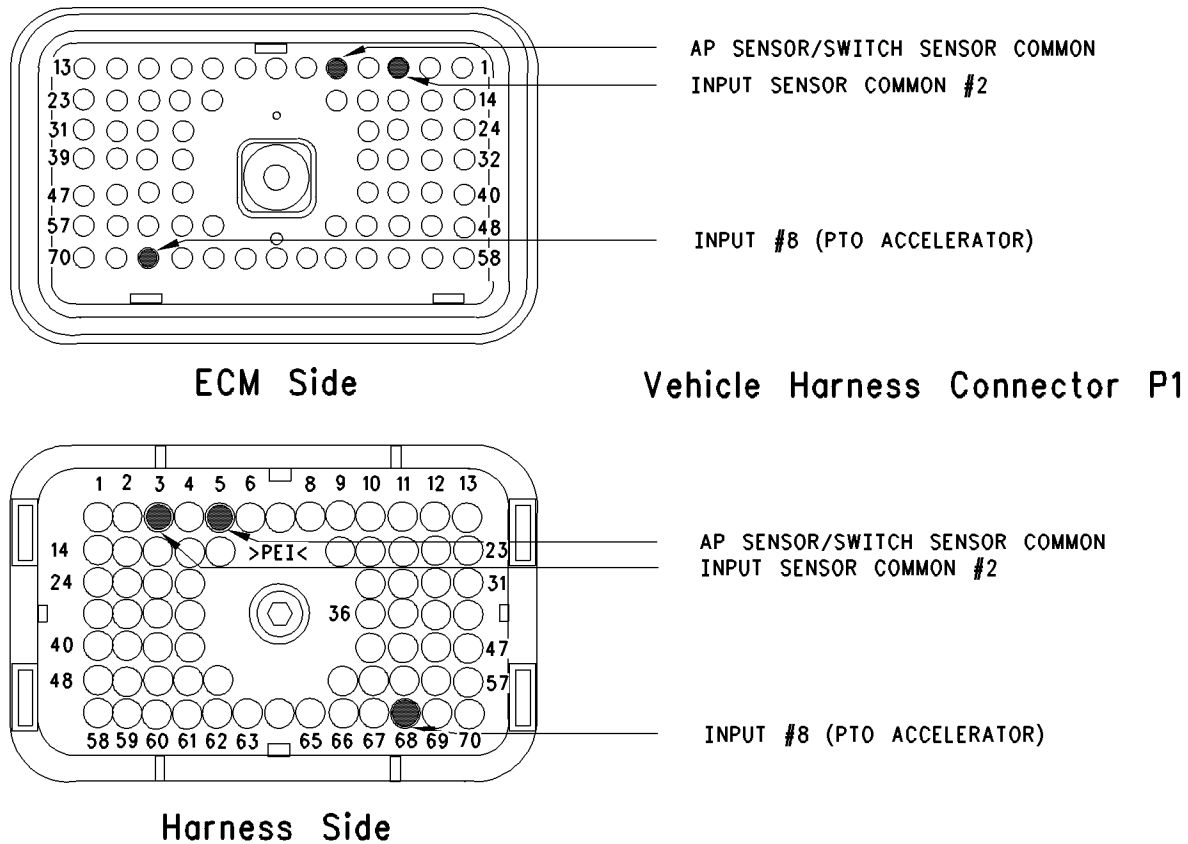

Illustration 165

g00642018

Terminal locations for ECM

Test Step 1. Inspect Electrical Connectors and Wiring

- A.** Connect ET to the cab data link connector. Verify that the parameter for the PTO Configuration is programmed to the "Remote Throttle".
- B.** Thoroughly inspect ECM vehicle harness connector J1/P1, the firewall bulkhead connector and the connector for the remote accelerator position sensor. Refer to Troubleshooting, "Electrical Connectors - Inspect" for details.
- C.** Perform a 45 N (10 lb) pull test on each of the wires in the ECM connector that are associated with the remote accelerator position sensor:
 - J1/P1:68
- D.** Check the ECM connector (Allen Head Screw) for the proper torque of 6.0 N·m (55 lb in).

- E.** Check the harness and wiring for abrasion and pinch points from the remote accelerator position sensor to the ECM.

Expected Result:

All connectors, pins and sockets should be completely coupled and/or inserted and the harness and wiring should be free of corrosion, abrasion or pinch points.

Results:

- OK – Proceed to Test Step 2.
- Not OK

Repair: Perform the following diagnostic procedure:

Repair the connectors or wiring and/or replace the connectors or wiring. Ensure that all of the seals are properly in place and ensure that the connectors are completely coupled.

Verify that the repair eliminates the problem.

STOP.

Test Step 2. Check for Active Diagnostic Codes

- A. Connect ET to the cab data link connector.
- B. Turn the ignition key switch to the ON position.
- C. Monitor the active diagnostic code screen on ET. Check and record active diagnostic codes.

Note: When the ECM automatically calibrates new duty cycle values for the low idle throttle position and the high idle throttle position the ECM assumes 22 percent duty cycle at low idle and 75 percent duty cycle at high idle. As a result, you may notice that the PTO throttle position status reaches 100 percent well before the remote PTO accelerator pedal is fully depressed. This is normal. After some cycling of the accelerator pedal to the high idle position, the ECM will adjust the calibration automatically. The ECM will adjust the calibration automatically provided that the high idle stop position is within the 75 to 90 percent duty cycle range, and the low idle is in the 10 to 22 percent duty cycle range. During normal operation, you may notice that more movement of the remote PTO accelerator pedal is required for the PTO throttle position status to increase above 3 percent. You may also observe that the status reaches the 100 percent value prior to the limit of the high idle position. This is done in order to ensure that the accelerator reaches these two critical points for engine operation.

Expected Result:

Result 1 Diagnostic Code 30-08 or 30-13 is active.

Result 2 There are no active diagnostic codes that are related to the accelerator position sensor circuit at this time, but a problem is suspected with operation of the remote PTO accelerator position sensor circuit.

Results:

- Result 1 – Proceed to Test Step 3.
- Result 2 – Proceed to Test Step 3.

Test Step 3. Check the Supply Voltage for the Remote Accelerator Position Sensor

- A. Turn the ignition key switch to the ON position.

- B. Measure the voltage at terminal “A” (+12 V) with reference to terminal “B” (sensor common) at the connector J406. This connector is for the remote accelerator position sensor.

Expected Result:

The measured voltage is between 11.0 VDC and 13.5 VDC.

Results:

- OK – The voltage is OK. Proceed to Test Step 4.
- Not OK – The vehicle wiring or the battery is causing the problem. Repair the wiring or the battery. Replace the wiring or the battery. Perform the repair that is necessary. Verify that the repair has fixed the problem. STOP.

Test Step 4. Check the Duty Cycle of the Remote Accelerator Pedal Position Sensor

- A. Turn the ignition key switch to the ON position.
- B. Monitor the duty cycle of the PTO throttle sensor on ET. Access the following display screen in order:
 - “Service”
 - “Calibrations”
 - “Monitor Throttle Position Sensor”

Expected Result:

The duty cycle is between 10 and 22 percent with the accelerator pedal assembly in the low idle position, and the duty cycle is between 75 and 90 percent with the accelerator pedal assembly in the high idle position.

Results:

- OK – The remote accelerator position sensor is operating correctly. Proceed to Test Step 5.
- Not OK – The remote accelerator position sensor circuit is not operating correctly. Proceed to Test Step 6.

Test Step 5. Check the Status of the Power Train Data Link on ET

- A. Start the engine. While the status of the PTO throttle position is being monitored on ET, depress the remote PTO accelerator pedal and release the remote PTO accelerator pedal. The throttle position status and the engine should respond to the change in the accelerator pedal position.

B. Go to the “System Troubleshooting Settings” portion of ET and turn off the power train data link.

C. While the status of the PTO throttle position is being monitored on ET, depress the accelerator pedal and release the accelerator pedal. Also depress the accelerator pedal and release the accelerator pedal while the engine response is being monitored.

Expected Result:

The status of the PTO throttle position and the engine should respond to the change in the accelerator pedal position.

Result 1 The PTO accelerator is functioning properly.

Result 2 The throttle response is limited by a power train data link message.

Results:

- **Result 1** – The remote accelerator position sensor is operating correctly. Continue troubleshooting until the original condition is resolved. **STOP.**
- **Result 2** – If the engine responds with the power train data link in the OFF position, but not with the power train data link in the ON position, a component of the power train data link is causing the response problem of the remote accelerator position sensor. Send the truck to the vehicle manufacturer in order to repair the faulty component of the power train data link. **STOP.**

Test Step 6. Check the Duty Cycle of the Remote Accelerator Position Sensor at the Sensor

Note: Performing certain steps within this procedure requires the use of a multimeter that is capable of measuring a PWM duty cycle.

- A.** Turn the ignition key switch to the OFF position.
- B.** Remove the signal wire for the remote accelerator position sensor (terminal “C”) from J406. This is the vehicle harness side of the connector for the accelerator position sensor.
- C.** Install a breakout T with 3 terminals at the connector J406/P406 for the remote accelerator position sensor.
- D.** Connect the multimeter probes to terminal “C” (Accelerator Pedal Position) and terminal “B” (Accelerator/Switch Sensor Common) of the breakout T.

E. While the duty cycle is being monitored on the multimeter, depress the accelerator pedal and release the accelerator pedal.

Expected Result:

The duty cycle is between 10 and 22 percent with the accelerator pedal assembly in the low idle position, and the duty cycle is between 75 and 90 percent with the accelerator pedal assembly in the high idle position.

Results:

- **OK** – Reinsert the wire (terminal “C”) into the connector for the remote accelerator position sensor. The sensor is working correctly. Proceed to Test Step 7.
- **Not OK** – Leave the PWM probe connected to the breakout T. Insert the wire (terminal “C”) into the connector for the remote accelerator position sensor. The sensor or the accelerator pedal assembly is faulty. Proceed to Test Step 8.

Test Step 7. Check the Duty Cycle of the Remote Accelerator Position Sensor at the ECM

Note: Performing certain steps within this procedure requires the use of a multimeter that is capable of measuring a PWM duty cycle.

- A.** Turn the ignition key switch to the OFF position.
- B.** Remove the wire from P1:68 (Remote Accelerator Position Sensor) from ECM connector P1/J1.
- C.** Connect the multimeter probes between the removed wire and the ECM sensor common or ground.
- D.** Turn the ignition key switch to the ON position.
- E.** Use the multimeter in order to display the duty cycle output of the accelerator position sensor. While the duty cycle output of the remote accelerator position sensor is being monitored on the multimeter, move the accelerator assembly from the low idle position to the high idle position. Record the results.
- F.** Turn the ignition key switch to the OFF position.
- G.** Insert terminal 68 into the ECM vehicle connector P1/J1 (70 Terminal).

Expected Result:

The duty cycle is between 10 and 22 percent with the accelerator pedal assembly in the low idle position, and the duty cycle is between 75 and 90 percent with the accelerator pedal assembly in the high idle position.

Results:

- **OK** – A good signal from the remote accelerator position sensor is reaching the ECM. Verify that the ECM is receiving the proper battery voltage. If the ECM is receiving the proper battery voltage, temporarily connect a test ECM and verify that the problem is resolved. If the problem disappears with the test ECM, reconnect the suspect ECM. If the problem returns with the suspect ECM, replace the ECM. **STOP**.
- **Not OK** – There is a problem with signal wire for the remote accelerator position sensor in the vehicle wiring harness. Proceed to Test Step 9.

Test Step 8. Remove the Remote Accelerator Position Sensor From the Accelerator Pedal Assembly

- A. Turn the ignition key switch to the OFF position.
- B. Remove the remote accelerator position sensor from the accelerator pedal assembly. Note sensor orientation in the accelerator pedal assembly, and the sensor pigtail routing prior to sensor removal. Thoroughly inspect the pigtail for signs of abrasion.
- C. Connect the multimeter that is capable of measuring a PWM duty cycle to terminal “C” of the breakout T.
- D. Turn the ignition key switch to the ON position.
- E. Display the duty cycle output of the remote accelerator position sensor while the sensor slot is released. Use a screwdriver to advance the sensor slot to the maximum position. Refer to Illustration 166.

When the sensor is removed from the accelerator pedal assembly the following diagnostic codes may be generated:

- 30-13 PTO Throttle Sensor Calibration (29)

The diagnostic code should disappear when the sensor is properly assembled back into the accelerator pedal assembly.

- A Mate sensor to accelerator pedal assembly. Key must match up with the sensor slot. Check the sensor housing for a flush fit to the pedal assembly mounting surface (This ensures slot on sensor has mated correctly with the pedal assembly key.)
- B Ensure the sensor is oriented the same as it was prior to removal to ensure sensor harness pigtail is routed correctly.
- C Line up screw holes and install mounting screws.

NOTE: Procedure is identical for the suspended accelerator pedal assembly.

(5) Accelerator Pedal Assembly

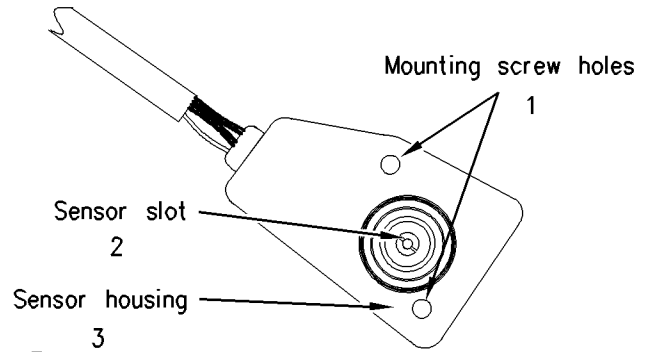
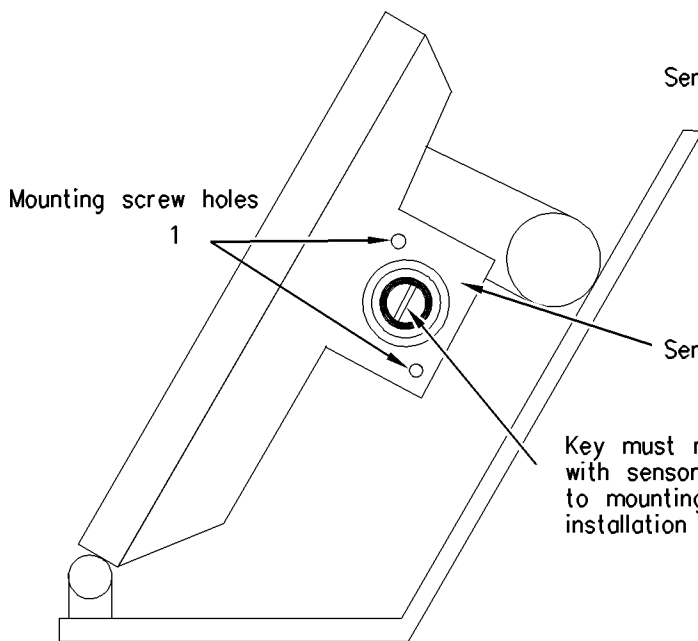

Accelerator Block Assembly

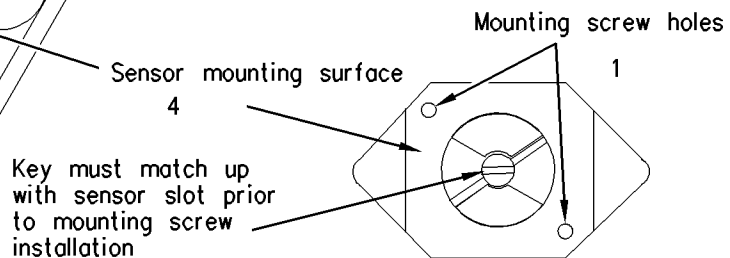

(6) Accelerator Block Assembly

Illustration 166

g00642019

(1) Mounting screw holes
 (2) Sensor slot

(3) Sensor housing
 (4) Mounting surface for sensor

(5) Accelerator pedal assembly
 (6) Accelerator block assembly

Expected Result:

When the sensor is removed from the accelerator pedal assembly and the sensor slot is released, the duty cycle is 10 percent or less. When the sensor slot is moved to the maximum position, the duty cycle increases to 90 percent or more.

Results:

- **OK** – The remote accelerator position sensor is working correctly. Clear any diagnostic codes that were caused by performing this test procedure. Refer to the OEM dealer for correct replacement of the accelerator pedal assembly. **STOP.**

- **Not OK** – The remote accelerator position sensor is faulty. Check the accelerator pedal assembly in order to ensure that the accelerator pedal assembly is not causing damage to the sensor. If the accelerator pedal assembly is causing damage to the sensor, refer to the OEM dealer for correct replacement of the accelerator pedal assembly. **STOP.**

Test Step 9. Route the Supply Bypass Wires to the Remote Accelerator Pedal Position Sensor

- A.** Turn the ignition key switch to the OFF position.

- B.** Remove P1:66 remote accelerator position sensor from the ECM connector P1.
- C.** Remove terminal “C” (Accelerator Pedal Position) from the connector for the remote accelerator position sensor.
- D.** Route new wiring from the ECM to the remote accelerator position sensor.
- E.** Turn the ignition key switch to the ON position.
- F.** Check the duty cycle of the remote accelerator position sensor with ET while the accelerator pedal assembly is being moved over the full range.

Expected Result:

The duty cycle is between 10 and 22 percent with the accelerator pedal assembly in the low idle position, and the duty cycle is between 75 and 90 percent with the accelerator pedal assembly in the high idle position.

Results:

- **OK** – The wiring from the ECM to the accelerator position sensor appears faulty. Permanently install new wiring. Verify that the repair eliminates the problem. **STOP.**
- **Not OK** – Double check the wiring, the ECM vehicle harness connector J1/P1 and the sensor connector. If a problem still exists, restart the test procedure. **STOP.**

i01858070

Service Brake Pedal Position (Switch 1) Circuit - Test

SMCS Code: 1900-081-ZS

System Operation Description:**Use this procedure under the following situation:**

Use this procedure to determine if the Service Brake Pedal Position (Switch 1) is preventing normal operation of cruise control, fast idle, idle set speed, or PTO operation:

The following switch circuits can also prevent the correct operation of the cruise control, fast idle, idle set speed or PTO operation:

- Service Brake Pedal Position (Switch 2)
- Neutral switch
- Cruise Control Set/Resume Switch

- Cruise Control On/Off Switch
- PTO On/Off Switch
- Cruise Control Pause Switch

The switches are described in the respective circuit tests in Troubleshooting.

All of the following Customer Programmable Parameters can affect cruise control, idle set speed, fast idle, and PTO operation:

- “Low Cruise Control Speed Set Limit”
- “High Cruise Control Speed Set Limit”
- “Idle Vehicle Speed Limit”
- “Fast Idle RPM #1”
- “Fast Idle RPM #2”
- “Cruise/Idle/PTO Switch Configuration”
- “Idle/PTO Bump rpm”
- “Idle/PTO rpm Ramp Rate”
- “PTO Vehicle Speed Limit”
- “Cruise Pause Switch”

The vehicle speed calibration can also affect the cruise control, fast idle, the idle set speed, and the PTO if the vehicle speed calibration is incorrectly programmed. Refer to Troubleshooting, “Customer Specified Parameters”.

Service Brake Pedal Position (Switch 1)

The switch for the Service Brake Pedal Position (Switch 1) is normally closed when the respective pedal is released. Depressing the brake pedal should open the individual circuit. This switch is OEM supplied. The Service Brake Pedal Position (Switch 1) is typically a pressure switch.

This switch may not be connected to an input on the ECM. The parameter “Service Brake Pedal Position Switch # 1” determines the input to the ECM. If the parameter is programmed to J1/P1:45 a switch must be connected to terminal 45. If the parameter is programmed to one of the J1939 options, the switch position will be transmitted to the ECM over the J1939 data link. If a problem is suspected with the J1939 data link, refer to Troubleshooting, “Powertrain Data Link Circuit - Test”.

The following background information is related to this procedure:

The kickout switch refers to the switch that is used to exit the Cruise Control, the PTO, fast idle, or the Idle Set Speed.

The operation of the Caterpillar Electronic Engine cruise control is similar to the operation of the cruise controls that are installed in automobiles. The operation of fast idle, idle, and PTO are similar to the operation of cruise except that the Idle and the PTO govern engine rpm instead of vehicle speed.

Note: Idle in this procedure is an engine idle rpm above the programmed low idle rpm. Idle is set by using the Cruise Control On/Off switch and the Set/Resume switch. Refer to Troubleshooting, "PTO Switch Circuit - Test" for additional information regarding the programmable options for the Dedicated PTO.

Note: Fast idle in this procedure is an engine idle rpm above the programmed low idle rpm. Fast idle is set by using a dedicated fast idle switch.

Cruise Control On/Off Switch

This switch must be ON before cruise control or controlled idle can be activated. This switch is ON when the switch is closed. When the switch is closed the following terminals are connected:

- ECM Connector J1/P1 terminal 59 (cruise control on/off switch)
- Terminal 5 (ap sensor/switch sensor common)

Note: If the vehicle is programmed to use the Dedicated PTO, the PTO On/Off switch overrides the Cruise Control On/Off switch. The PTO On/Off switch overrides the Cruise Control On/Off switch when the vehicle speed is within the range of the PTO Vehicle Speed Limit that is programmed.

Set/Resume Switch

With the Cruise Control On/Off Switch in the ON position and the vehicle speed within the range of the programmed Low Cruise Control Speed Set Limit and the High Cruise Control Speed Set Limit, momentarily pressing the Set Switch will activate cruise control and the ECM will maintain the current speed.

After a speed has been set and the speed is then disengaged by using the brake, the clutch, the cruise pause switch, or the on/off switch, the ECM will seek the previous set speed when the resume switch is toggled. This assumes that the vehicle speed is above the "Low Cruise Control Set Speed Limit" for cruise control or the vehicle speed is below the Idle/PTO Vehicle Speed Limit for the Idle and the PTO.

After a speed has been set, pressing and holding the Set/Resume switch in position will cause the engine to establish a new set speed. The system's reaction depends on the programming of the "Cruise/Idle/PTO Switch Configuration".

When the Set/Resume switch is momentarily pressed, the cruise set point will change one mph. The rate of change is dependent on the programmed "Idle/PTO Bump rpm" when an idle speed is set.

Cruise Pause Switch

The cruise pause switch is not a switch that is wired to an input. The switch position is broadcast over a J1939 data link. The parameter "Cruise Pause Switch" must be programmed to use a cruise pause switch. After a speed has been set and the speed is then disengaged by using the cruise pause switch, the ECM will seek the previous set speed when the resume switch is toggled. This assumes that the vehicle speed is above the "Low Cruise Control Speed Set Limit" for cruise control or the vehicle speed is below the "Idle/PTO Vehicle Speed Limit" for the idle and the PTO.

Kickout Switches

The service brake pedal position switches, the neutral switch and the clutch switch are used in the Cruise Control mode, the PTO mode, the Fast Idle mode, and the Idle mode in order to discontinue the Cruise operation, the PTO operation, the Fast Idle mode, or the Idle operation. The capability to override the Idle Shutdown Timer is determined by the "Allow Idle Shutdown Override" parameter setting. The "Allow Idle Shutdown Override" is a Customer Parameter.

Usage of Transmission Style Switches

The "Transmission Style" parameter determines the switches that will be used. The following switches can be used with being dependent on the parameter setting:

- Clutch Pedal Position
- Neutral
- Service Brake Pedal Position (Switch 1)
- Service Brake Pedal Position (Switch 2)

Refer to Table 185 for additional information.

Table 185

Setting For Transmission Style Parameter	Switch Usage.			
	Service Brake Switch 1	Service Brake Switch 2	Clutch	Neutral
“Manual Option 1”	X		X	
“Manual Option 2”	X	X	X	
“Automatic Option 1”	X			
“Automatic Option 2”	X	X		
“Automatic Option 3”	X	X		X
“Automatic Option 4”	X			X
“AT/MT/HT Option 1”	X			
“AT/MT/HT Option 2”	X	X		
“AT/MT/HT Option 3”	X	X		X
“AT/MT/HT Option 4”	X			X
“Universal Option”	X		X	X

If the “Transmission Style” parameter is programmed to one of the following options, the input for the Clutch Pedal Position Switch is not used.

- “Automatic Options 1”
- “Automatic Option 2”
- “Automatic Option 3”
- “Automatic Option 4”
- “AT/MT/HT Option 1”
- “AT/MT/HT Option 2”
- “AT/MT/HT Option 3”
- “AT/MT/HT Option 4”

A Service Brake Pedal Position (Switch 1) is required for all configurations. The Service Brake Pedal Position (Switch 1) connects to the ECM through connector P1 terminal 45. The Service Brake Pedal Position (Switch 2) connects to the ECM through Connector P1 terminal 64. The clutch pedal position switch connects to the ECM through connector P1 terminal 22. The neutral switch connects to the ECM through connector P1 terminal 62.

Some engines that were built before JULY 1999 may have a Basic ECM. The Basic ECM was used only on General Motors chassis. Other chassis used engines that were built with a Full Feature ECM. Basic ECM software does not have the parameter for “Transmission Style”. For these systems, a jumper wire must be installed between the clutch switch input and the sensor common when an automatic transmission is installed. When the jumper wire is installed, the “Clutch Switch” status will always indicate “OFF”. Engines that were built after JULY 1999 use only one type of ECM that can be configured for “Basic” or “Full Feature” operation. A new parameter was added in order to provide this flexibility. The “Truck Manufacturer” parameter was added in order to allow the configuration of the “GM Basic” operation or the “Other Full Feature” operation. This parameter is programmed at Caterpillar when the engine is built. The parameter for “Transmission Style” is not available for engines that have software that is dated prior to SEP00 and the parameter for “Truck Manufacturer” is programmed to “GM”. SEP00 and newer engines that are programmed to “GM” use the “Transmission Style” parameter. The factory default for the “GM” setting is the “Universal” option. The “Universal” option provides identical features as the “Basic” system that is described above. If the “Transmission Style” parameter is programmed to the “Universal” option, a jumper wire must be installed between the clutch switch input and the sensor common when an automatic transmission is installed. Otherwise, the “Transmission Style” parameter can be programmed to match the specific arrangement of the vehicle.

If the problem is with undetermined Cruise/Idle/PTO kickouts use the following procedure:

Operate the vehicle in Cruise/Idle/PTO mode.

After the kickout, review the status parameter on ET. The status parameter for the kickout indicates the cause. This must be performed before the ignition key switch is turned OFF. It is important to remember that the parameter will only indicate the last kickout since the ECM has been powered by the input of the ignition key switch.

This parameter is blank when the ECM is first powered up. If this parameter is blank, No Occurrence is indicated. This parameter remains blank until the ECM detects the use of the Cruise/Idle/PTO Mode. Also, this parameter remains blank until the ECM detects the disengagement of the Cruise/Idle/PTO Mode. Refer to Tables 186, 187, and 188 in order to interpret the status screen kickout status parameter.

The following Kickout Status parameters are available:

- “Cruise Kickout”
- “Idle Kickout”
- “PTO Kickout”
- “Fast Idle Kickout”

Table 186

Cruise Control Kickout Status Table		
ET	Meaning or Possible Cause	Troubleshooting
“Vehicle Speed >=Limit”	Intermittent vehicle speed signal or lost vehicle speed signal.	Refer to Troubleshooting, “Vehicle Speed Circuit - Test”.
“Switch Turned Off”	The cruise/idle on/off switch is turned off or the switch circuit has an open circuit condition.	Refer to Troubleshooting, “Cruise Control Switch Circuit - Test”.
“Cruise Control PAUSE Switch”	The cruise pause switch is depressed or there is an illegal message on the J1939 data link.	Refer to Troubleshooting, “Powertrain Data Link Circuit - Test”.
“Brake Pedal Depressed”	The service brake pedal is depressed or the service brake switch circuit has an open circuit condition.	Proceed with the test procedure.
“ClutchPedal Depressed”	The clutch pedal is depressed or the clutch pedal switch circuit has an open circuit condition. Also, the switch could be incorrectly adjusted.	Refer to Troubleshooting, “Clutch Pedal Position Switch Circuit - Test”.
“Neutral”	The transmission is not in gear or the transmission switch circuit has a short circuit condition.	Refer to Troubleshooting, “Neutral Switch Circuit - Test”.
“Bad Vehicle Speed”	Vehicle speed signal is erratic or intermittent.	Refer to Troubleshooting, “Vehicle Speed Circuit - Test” if a problem with the signal exists.
“PTO Switch On”	The PTO on/off switch is turned on or the circuit for the PTO on/off switch has a short circuit condition.	Refer to Troubleshooting, “PTO Switch Circuit - Test”.
Set Switch Timeout	The set/resume switch was held in the SET position for more than 15 seconds (Basic) or there is a short circuit in the switch circuit.	Cruise control cannot be set until the cruise control on/off switch is turned to the OFF position and then turned back to the ON position. If the circuit for the set switch is suspected, proceed with this test procedure.
Resume Switch Timeout	The set/resume switch was held in the SET position for more than 15 seconds (Basic) or there is a short circuit in the switch circuit.	Cruise control cannot be set until the cruise control on/off switch is turned to the OFF position and then turned back to the ON position. If the circuit for the resume switch is suspected, proceed with this test procedure.
“No Occurrence” or “Not Kicked Out”	Cruise control has not been enabled since the ECM has been powered up.	Drive the vehicle in cruise in order to create the problem again.

Table 187

Idle Kickout Status Table		
ET	Meaning or Possible Cause	Troubleshooting
“No Engine Speed”	Intermittent engine speed signal or lost engine speed signal.	Refer to Troubleshooting, “Engine Speed/Timing Circuit - Test”.
“Switch Turned Off”	The cruise/idle on/off switch is turned off or the switch circuit has an open circuit condition.	Refer to Troubleshooting, “Cruise Control Switch Circuit - Test”.
“Brake Pedal Depressed”	The service brake pedal is depressed or the service brake switch circuit has an open circuit condition.	Proceed with the test procedure.
“Clutch Pedal Depressed”	The clutch pedal is depressed or the clutch pedal switch circuit has an open circuit condition. Also, the switch could be incorrectly adjusted.	Refer to Troubleshooting, “Clutch Pedal Position Switch Circuit - Test”.
“Vehicle Speed \geq Limit”	The vehicle speed has exceeded the Idle Vehicle Speed Limit or the vehicle speed signal is erratic or intermittent.	Refer to Troubleshooting, “Vehicle Speed Circuit - Test” if a problem with the signal exists.
“Neutral”	The transmission is not in neutral or the transmission neutral switch circuit has an open circuit condition.	Refer to Troubleshooting, “Neutral Switch Circuit - Test”.
“PTO Switch On”	The PTO on/off switch is turned on or the circuit for the PTO on/off switch has a short circuit condition.	Refer to Troubleshooting, “PTO Switch Circuit - Test”.
“No Occurrence” or “Not Kicked Out”	Idle set speed has not been enabled since the ECM has been powered up.	Operate the vehicle in the Idle mode in order to create the problem again.

Table 188

Fast Idle Kickout Status Table		
ET	Meaning or Possible Cause	Troubleshooting
“No Engine Speed”	Intermittent engine speed signal or lost engine speed signal.	Refer to Troubleshooting, “Engine Speed/Timing Circuit - Test”.
“Switch Turned Off”	The fast idle on/off switch is turned off or the switch circuit has an open circuit condition.	Refer to Troubleshooting, “Cruise Control Switch Circuit - Test”.
“Brake Pedal Depressed”	The service brake pedal is depressed or the service brake switch circuit has an open circuit condition.	Proceed with the test procedure.
“Clutch Pedal Depressed”	The clutch pedal is depressed or the clutch pedal switch circuit has an open circuit condition. Also, the switch could be incorrectly adjusted.	Refer to Troubleshooting, “Clutch Pedal Position Switch Circuit - Test”.
“Vehicle Speed ≥ Limit”	The vehicle speed has exceeded the Idle Vehicle Speed Limit or the vehicle speed signal is erratic or intermittent.	Refer to Troubleshooting, “Vehicle Speed Circuit - Test” if a problem with the signal exists.
“Neutral”	The transmission is not in neutral or the transmission neutral switch circuit has an open circuit condition.	Refer to Troubleshooting, “Neutral Switch Circuit - Test”.
“No Occurrence” or “Not Kicked Out”	Fast idle set speed has not been exited since the ECM has been powered up.	Operate the vehicle in the Idle mode in order to create the problem again.

Table 189

Table For The PTO Kickout Status Screen On ET		
ET	Meaning or Possible Cause	Troubleshooting
No Engine Speed	Intermittent engine speed signal or lost engine speed signal.	Refer to Troubleshooting, “Speed/Timing Circuit - Test”.
Switch Turned Off	The PTO On/Off switch is turned OFF or the switch circuit has an open circuit condition.	Refer to Troubleshooting, “Clutch Pedal Position Switch Circuit - Test”.
“Brake Pedal Depressed”	The service brake pedal is depressed or the service brake switch circuit has an open circuit condition.	Proceed with the test procedure.
“Clutch Pedal Depressed”	The clutch pedal is depressed or the clutch pedal switch circuit has an open circuit condition. Also, the switch could be incorrectly adjusted.	Refer to Troubleshooting, “Clutch Pedal Position Switch Circuit - Test”.
Vehicle Speed ≥ Limit	The vehicle speed has exceeded the PTO Vehicle Speed Limit or the vehicle speed signal is erratic or intermittent.	Refer to Troubleshooting, “Vehicle Speed Circuit - Test” if a problem with the signal exists.
Neutral	The transmission is not in neutral or the transmission neutral switch circuit has an open circuit condition.	Refer to Troubleshooting, “Neutral Switch Circuit - Test”.
“No Occurrence” or “Not Kicked Out”	The PTO has not been enabled since the ECM has been powered up.	Operate the vehicle in the PTO mode in order to create the problem again.

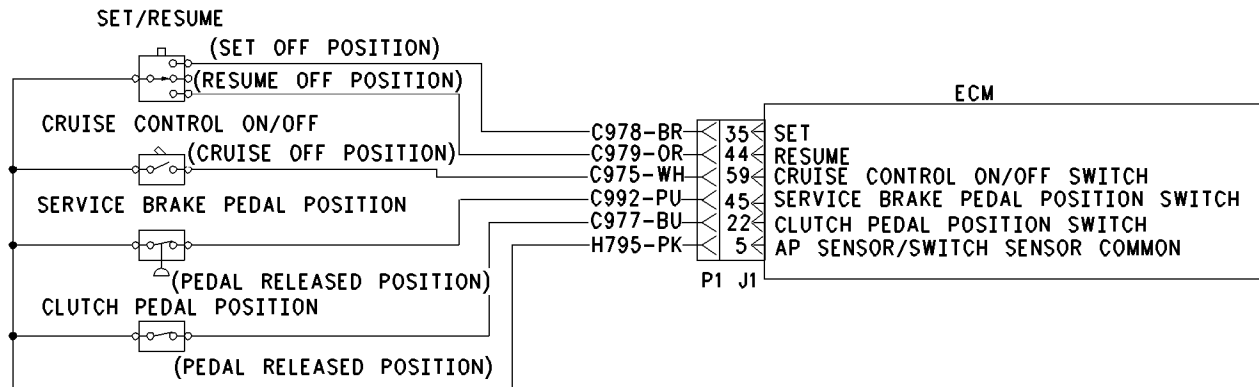

Illustration 167

g00643881

Schematic for cruise control switch, service brake pedal position (switch 1) and clutch pedal position switch

Test Step 1. Determine the Type of Problem.

- A. Connect ET to the cab data link connector.
- B. Turn the ignition key switch to the ON position.
- C. If the vehicle will not allow setting a cruise speed, an idle speed or a PTO speed, check the following Customer Parameters:

Cruise Control Parameters

- “Low Cruise Control Speed Set Limit”
- “High Cruise Control Speed Set Limit”

Idle Parameters

- “Fast Idle RPM #1”
- “Fast Idle RPM #2”
- “Idle Vehicle Speed Limit”
- “Idle RPM Limit”
- “Top Engine Limit” (TEL)

PTO Parameters

- “PTO Configuration”
- “PTO Vehicle Speed Limit”

- D. Ensure that the vehicle is not experiencing a problem due to one of these parameters. Refer to Troubleshooting, “Customer Specified Parameters” for a description of the parameters, if necessary.
- E. Check the ET status screen that indicates the last cause of a kickout for one of the following items:
 - Cruise Control Kickout
 - Idle Kickout
 - Fast Idle Kickout
 - PTO Kickout

Refer to Tables 186, 187, 188, and 189 for the meaning of the ET status parameter.

Expected Result:

The problem is due to a parameter setting or the problem is due to a normal kickout.

Results:

- Yes – Explain the proper operation of system to the driver. STOP.
- No

Repair: Refer to tables 186, 187, 188, and 189 for recommended troubleshooting.

If a problem is still suspected with the circuit for the Service Brake Pedal Position (Switch 1), perform the following procedure:

Proceed to Test Step 2.

Test Step 2. Inspect Electrical Connectors and Wiring.

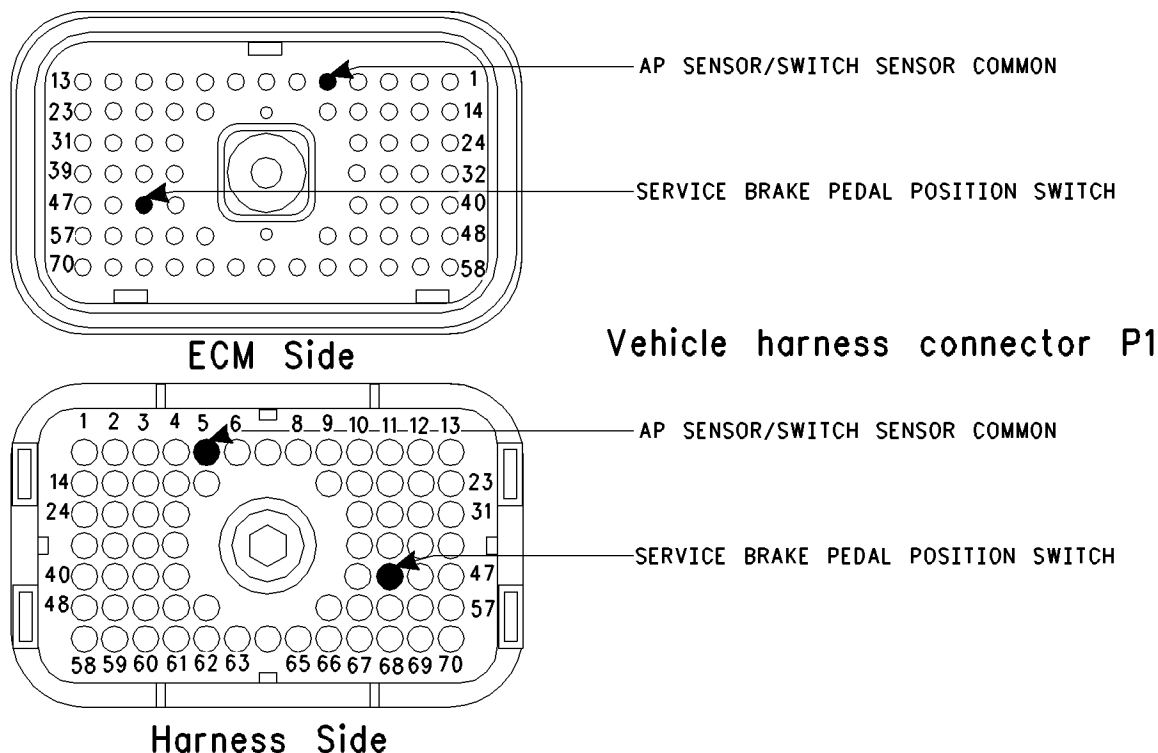

Illustration 168

g00702676

A. Thoroughly inspect ECM vehicle harness connector J1/P1, the firewall bulkhead connector and the terminals for the following switches in the connectors:

- AP Sensor/Switch Sensor Common (terminal 5)
- Service Brake Pedal Position (Switch 1) (terminal 45)

Refer to Troubleshooting, “Electrical Connectors - Inspect” for details.

B. Perform a 45 N (10 lb) pull test on each of the wires in the ECM connector that are associated with the switches.

Refer to Illustration 168.

C. Check the ECM connector (allen head screw) for the proper torque of 6.0 N·m (55 lb in).

D. Check the harness and wiring for abrasion and pinch points from the sensor to the ECM.

Expected Result:

All connectors, pins and sockets should be completely coupled and/or inserted and the harness and wiring should be free of corrosion, abrasion or pinch points.

Results:

- OK – Proceed to Test Step 3.
- Not OK

Repair: Perform the following repair:

Repair the connectors or wiring and/or replace the connectors or wiring. Ensure that all of the seals are properly in place and ensure that the connectors are completely coupled.

Verify that the repair eliminates the problem.

STOP.

Test Step 3. Check the Service Brake Switch Status on ET.

Table 190

Table for Status of the Service Brake Pedal Position		
Switch Position or Pedal Position	Status	Circuit
The Service Brake Pedal is DEPRESSED.	ON	Open
The Service Brake Pedal is RELEASED.	OFF	Closed

- A. Access the ET status screen.
- B. Turn the ignition key switch to the ON position.
- C. Depress the service brake while the status of the service brake pedal position (switch 1) is being observed. Also, release the service brake while the status of the service brake pedal position (switch 1) is being observed.

Refer to Table 190 for the status of the switch or for the status of the pedal position.

Expected Result:

The switch status changes per the information in Table 190.

Results:

- **Yes** – The switch is operating normally. **STOP**.
- **Intermittent Problem Suspected** – Proceed to Test Step 4.
- **No** – The ECM is not reading the switch status change. Proceed to Test Step 5.

Test Step 4. Operate the Vehicle and Check the Kickout Status Parameter.

- A. For an intermittent Cruise Control Kickout, talk to the driver in order to determine the conditions when the kickout occurs. Topics of examination could be the following examples:
 - specific speed
 - road conditions
 - weather conditions

Take the vehicle for a road test in order to duplicate these conditions and set the cruise control. Operate the vehicle in cruise control until the problem reoccurs.

- B. For an intermittent Idle Kickout, talk to the driver in order to determine the conditions when the kickout occurs. A topic of examination could be the following example:
 - Specific engine rpm

Start the engine. Duplicate these conditions and set the idle rpm. Operate the vehicle in idle until the problem reoccurs.

Note: The ET status screen will only indicate the last kickout. The ET status screen will lose this information if the ignition key switch is turned OFF.

- C. Connect ET and check the status screen for the last cause of the kickout. Refer to Tables 186, 187, 188, and 189 for an explanation of the status parameter.
- D. If the ET status screen is blank, then either there was no kickout of the cruise control, or the power to the ECM was turned off before the information could be read. Repeat this test step.

Note: An ET status screen that is blank indicates No Occurrence.

Expected Result:

RESULT 1 The ET Kickout Status displays the following result:

- “Brake”

RESULT 2 The ET Kickout Status displays the following result:

- “Switch Turned Off”

RESULT 3 The ET Kickout Status displays the following result:

- “Cruise Control PAUSE Switch”

RESULT 4 The ET Kickout Status displays the following result:

- “Clutch”

RESULT 5 The ET Kickout Status displays the following result:

- “Vehicle Speed < Limit”
- “Bad Vehicle Speed”
- “Vehicle Speed ≥ Limit”

RESULT 6 The ET Kickout Status displays the following result:

- “PTO Switch ON”

RESULT 7 The ET Kickout Status displays the following result:

- “Neutral”

RESULT 8 The ET Kickout Status displays the following result:

- “No Engine Speed”

RESULT 9 The ET Kickout Status displays the following result:

- “Ser Switch Timeout”
- “Resume Switch Timeout”

Results:

- **Result 1** – Proceed to Test Step 5.
- **Result 2**

Repair: Perform the following diagnostic procedure:

Troubleshooting, “Cruise Control Switch Circuit - Test”

STOP.

- **Result 3**

Repair: Perform the following diagnostic procedure:

Troubleshooting, “Powertrain Data Link Circuit - Test”

STOP.

- **Result 5**

Repair: Perform the following diagnostic procedure:

Troubleshooting, “Clutch Pedal Position Switch Circuit - Test”

STOP.

- **Result 5**

Repair: Perform the following diagnostic procedures:

Troubleshooting, “Vehicle Speed and Speedometer Circuit - Test”

STOP.

- **Result 6**

Repair: Perform the following diagnostic procedure:

Troubleshooting, “PTO Switch Circuit - Test”

STOP.

- **Result 7**

Repair: Perform the following diagnostic procedure:

Troubleshooting, “Neutral Switch Circuit - Test”

STOP.

- **Result 8**

Repair: Perform the following diagnostic procedure:

Troubleshooting, “Engine Speed/Timing Sensor Circuit - Test”

STOP.

- **Result 9**

Repair: Perform the following diagnostic procedure:

Troubleshooting, “Cruise Control Switch Circuit - Test”.

STOP.

Test Step 5. Check the Switch Circuit.

Table 191

Table for Status of Service Brake Pedal Position (Switch 1)		
Condition of Switch Circuit	Switch Status	Circuit
Terminal 45 is Open.	ON	Open
Terminal 45 connected to terminal 5.	OFF	Shorted

- Turn the ignition key switch to the OFF position.
- Fabricate a jumper wire 100 mm (4 inch) long. Crimp a Deutsch Pin to both ends of the wires.
- Disconnect vehicle harness connector P1 from the ECM.
- Connect a breakout T to ECM Connector J1 and connect P1 to the breakout T.

- E. Install the jumper into terminal 45 Service Brake Pedal Position Switch 1 of the Breakout T. Connect the other end of the jumper to ECM Connector P1 terminal 5 (AP sensor/switch sensor common) of the Breakout T.
- F. Turn the ignition key switch to the ON position.
- G. Connect an electronic service tool to the cab data link connector.
- H. Access the electronic service tool status screen.
- I. While the status of the Service Brake Pedal Position (Switch 1) is being monitored on the electronic service tool status screen slowly remove the jumper from terminal 5 and slowly insert the jumper from terminal 5 (AP sensor/switch sensor common).

Refer to Table 191.

Expected Result:

The switch status changes per the information in Table 191.

Results:

- **Yes** – The ECM is functioning properly. Proceed to Test Step 6.
- **No** – The ECM is NOT functioning properly.

Repair: Perform the following repair:

1. Temporarily connect a test ECM.
2. Remove all jumpers and replace all connectors.
3. Recheck the system for active diagnostic codes.
4. Repeat the test step.
5. If the problem is resolved with the test ECM, reconnect the suspect ECM.
6. If the problem returns with the suspect ECM, replace the ECM.
7. Verify that the repair eliminates the problem.

STOP.

Test Step 6. Insert a Jumper at the Service Brake Pedal Position (Switch 1).

Table 192

Table for Status of the Service Brake Pedal Position (Switch 1)		
Condition of Switch Circuit	Switch Status	Circuit
Service Brake Pedal Position Switch 1 Wires are Disconnected.	ON	Open
Service Brake Pedal Position Switch 1 Wires Connected.	OFF	Shorted

- A. Turn the ignition key switch to the OFF position.
- B. Ensure that ECM vehicle harness connector J1/P1 is connected.
- C. Find the switch for the Service Brake Pedal Position (Switch 1) in the vehicle.
- D. Disconnect the wires from the switch terminals.
- E. Turn the ignition key switch to the ON position.
- F. Connect the electronic service tool to the cab data link connector.
- G. Access the electronic service tool status screen.
- H. While the switch status is being monitored on the electronic service tool status screen slowly connect the switch wires and slowly disconnect the switch wires.

Refer to Table 192.

Expected Result:

The switch status changes per the information in Table 192.

Results:

- **Yes**

Repair: Perform the following repair:

Replace the faulty switch.

Verify that the repair eliminates the problem.

STOP.

- **No** – There is a problem in the harness between the switch and the ECM. Proceed to Test Step 7.

Test Step 7. Insert a Jumper at the Bulkhead Connector.

Table 193

Table for Status of the Service Brake Pedal Position (Switch 1)		
Switch Position or Pedal Position	Switch Status	Circuit
Service Brake Pedal Position Switch 1 Wire is Disconnected.	ON	Open
Service Brake Pedal Position Switch 1 Wire Connected.	OFF	Shorted

- A. Turn the ignition key switch to the OFF position.
- B. Fabricate a jumper wire 100 mm (4 inch) long. Crimp a Deutsch Pin to each end of the wires.
- C. Find the switch for the terminal for the Service Brake Pedal Position (Switch 1). Also find the terminal for the sensor common for the AP Sensor/Switch in the engine side of the bulkhead connector for the vehicle harness.
- D. Insert the jumper wire between the two terminals in the engine side of the bulkhead connector.
- E. Turn the ignition key switch to the ON position.
- F. Connect the electronic service tool to the cab data link connector.
- G. Access the electronic service tool status screen.
- H. While the switch status is being monitored on the electronic service tool status screen alternately remove the jumper wire between the two terminals, and alternately insert the jumper wire between the two terminals.

Refer to Table 193.

Expected Result:

The switch status changes per the information in Table 193.

Results:

- **Yes** – The problem is in the vehicle wiring between the bulkhead connector and the switch.

Repair: Perform the following repair:

Inspect the vehicle wiring and repair the vehicle wiring, as required. If the problem still exists with the wiring, send the vehicle to the OEM dealer.

STOP.

- **No** – The problem is in the vehicle wiring between the bulkhead connector and the ECM.

Repair: Perform the following repair:

Inspect the vehicle wiring and repair the vehicle wiring, as required. If the problem still exists with the wiring, send the vehicle to the OEM dealer.

STOP.

i01858135

Service Brake Pedal Position (Switch 2) Circuit - Test

SMCS Code: 1900-081-ZS

System Operation Description:**Use this procedure under the following situation:**

Use this procedure to determine if the Service Brake Pedal Position (Switch 2) is preventing normal operation of cruise control, fast idle, idle set speed, or PTO operation:

The following switch circuits can also prevent the correct operation of the cruise control, fast idle, idle set speed or PTO operation:

- Service brake pedal position (switch 1)
- Neutral switch
- Cruise control set/resume switch
- Cruise control on/off switch
- PTO on/off switch
- Cruise control pause switch

The switches are described in the respective circuit tests in Troubleshooting.

All of the following Customer Programmable Parameters can affect cruise control, idle set speed, fast idle, and PTO operation:

- “Low Cruise Control Speed Set Limit”
- “High Cruise Control Speed Set Limit”
- “Idle Vehicle Speed Limit”
- “Fast Idle RPM #1”
- “Fast Idle RPM #2”
- “Cruise/Idle/PTO Switch Configuration”

- “Idle/PTO Bump rpm”
- “Idle/PTO rpm Ramp Rate”
- “PTO Vehicle Speed Limit”
- “Cruise control pause switch”

The vehicle speed calibration can also affect the cruise control, fast idle, the idle set speed, and the PTO if the vehicle speed calibration is incorrectly programmed. Refer to Troubleshooting, “Customer Specified Parameters”.

Service Brake Pedal Position (Switch 2)

The switch for the service brake pedal position (switch 2) is normally open when the respective pedal is released. Depressing the brake pedal should close the individual circuit. This switch is OEM supplied. The service brake pedal position (switch 2) is typically a pressure switch.

The following background information is related to this procedure:

The kickout switch refers to the switch that is used to exit the cruise control, the PTO, fast idle, or the idle set speed.

The operation of the Caterpillar electronic engine cruise control is similar to the operation of the cruise controls that are installed in automobiles. The operation of fast idle, idle, and PTO are similar to the operation of cruise except that the Idle and the PTO govern engine rpm instead of vehicle speed.

Note: Idle in this procedure is an engine idle rpm above the programmed low idle rpm. Idle is set by using the Cruise Control On/Off switch and the Set/Resume switch. Refer to Troubleshooting, “PTO Switch Circuit - Test” for additional information regarding the programmable options for the Dedicated PTO.

Note: Fast idle in this procedure is an engine idle rpm above the programmed low idle rpm. Fast idle is set by using a dedicated fast idle switch.

Cruise Control On/Off Switch

This switch must be ON before cruise control or controlled idle can be activated. This switch is ON when the switch is closed. When the switch is closed the following terminals are connected:

- ECM connector J1/P1 terminal 59 (cruise control on/off switch)
- Terminal 5 (AP sensor/switch sensor common)

Note: If the vehicle is programmed to use the Dedicated PTO, the PTO on/off switch overrides the cruise control on/off switch. The PTO on/off switch overrides the cruise control on/off switch when the vehicle speed is within the range of the “PTO Vehicle Speed Limit” that is programmed.

Set/Resume Switch

With the cruise control on/off switch in the ON position and the vehicle speed within the range of the programmed Low Cruise Control Speed Set Limit and the High Cruise Control Speed Set Limit, momentarily pressing the set switch will activate cruise control and the ECM will maintain the current speed.

After a speed has been set and the speed is then disengaged by using the brake, the clutch, the cruise control pause switch, or the on/off switch, the ECM will seek the previous set speed when the resume switch is toggled. This assumes that the vehicle speed is above the “Low Cruise Control Set Speed Limit” for cruise control or the vehicle speed is below the “Idle/PTO Vehicle Speed Limit” for the idle and the PTO.

After a speed has been set, pressing and holding the set/resume switch in position will cause the engine to establish a new set speed. The system’s reaction depends on the programming of the “Cruise/Idle/PTO Switch Configuration”.

When the set/resume switch is momentarily pressed, the cruise set point will change one mph. The rate of change is dependent on the programmed “Idle/PTO Bump rpm” when an idle speed is set.

Cruise Control Pause Switch

The cruise control pause switch is not a switch that is wired to an input. The switch position is broadcast over a J1939 data link. The parameter “Cruise Pause Switch” must be programmed to use a cruise control pause switch. After a speed has been set and the speed is then disengaged by using the cruise control pause switch, the ECM will seek the previous set speed when the resume switch is toggled. This assumes that the vehicle speed is above the “Low Cruise Control Speed Set Limit” for cruise control or the vehicle speed is below the “Idle/PTO Vehicle Speed Limit” for the idle and the PTO.

Kickout Switches

The service brake pedal position switches, the neutral switch and the clutch switch are used in the cruise control mode, the PTO mode, the fast idle mode, and the idle mode in order to discontinue the cruise operation, the PTO operation, the fast idle mode, or the idle operation. The capability to override the idle shutdown timer is determined by the “Allow Idle Shutdown Override” parameter setting. The “Allow Idle Shutdown Override” is a Customer Parameter.

Usage of Transmission Style Switches

The “Transmission Style” parameter determines the switches that will be used. The following switches can be used with being dependent on the parameter setting:

- Clutch pedal position
- Neutral
- Service brake pedal position (switch 1)
- Service brake pedal position (switch 2)

Refer to Table 194 for additional information.

Table 194

Setting For Transmission Style Parameter	Switch Usage.			
	Service Brake Switch 1	Service Brake Switch 2	Clutch	Neutral
“Manual”	X		X	
“Automatic Option 1”	X			
“Automatic Option 2”	X	X		
“Automatic Option 3”	X	X		X
“Automatic Option 4”	X			X
“AT/MT/HT Option 1”	X			
“AT/MT/HT Option 2”	X	X		
“AT/MT/HT Option 3”	X	X		X
“AT/MT/HT Option 4”	X			X
“Universal Option”	X		X	X

If the “Transmission Style” parameter is programmed to one of the following options, the input for the Clutch Pedal Position Switch is not used.

- “Automatic Option 1”
- “Automatic Option 2”
- “Automatic Option 3”
- “Automatic Option 4”
- “AT/MT/HT Option 1”
- “AT/MT/HT Option 2”
- “AT/MT/HT Option 3”
- “AT/MT/HT Option 4”

A service brake pedal position (switch 1) is required for all configurations. The service brake pedal position (switch 1) connects to the ECM through connector P1 terminal 45. The service brake pedal position (switch 2) connects to the ECM through connector P1 terminal 64. The clutch pedal position switch connects to the ECM through connector P1 terminal 22. The neutral switch connects to the ECM through connector P1 terminal 62.

Some engines that were built before JULY 1999 may have a Basic ECM. The Basic ECM was used only on General Motors chassis. Other chassis used engines that were built with a Full Feature ECM. Basic ECM software does not have the parameter for “Transmission Style”. For these systems, a jumper wire must be installed between the clutch switch input and the sensor common when an automatic transmission is installed. When the jumper wire is installed, the “Clutch Switch” status will always indicate “OFF”. Engines that were built after JULY 1999 use only one type of ECM that can be configured for “Basic” or “Full Feature” operation. A new parameter was added in order to provide this flexibility. The “Truck Manufacturer” parameter was added in order to allow the configuration of the “GM Basic” operation or the “Other Full Feature” operation. This parameter is programmed at Caterpillar when the engine is built. The parameter for “Transmission Style” is not available for engines that have software that is dated prior to SEP00 and the parameter for “Truck Manufacturer” is programmed to “GM”. SEP00 and newer engines that are programmed to “GM” use the “Transmission Style” parameter. The factory default for the “GM” setting is the “Universal” option. The “Universal” option provides identical features as the “Basic” system that is described above. If the “Transmission Style” parameter is programmed to the “Universal” option, a jumper wire must be installed between the clutch switch input and the sensor common when an automatic transmission is installed. Otherwise, the “Transmission Style” parameter can be programmed to match the specific arrangement of the vehicle.

**If the problem is with undetermined
Cruise/Idle/PTO kickouts use the following
procedure:**

Operate the vehicle in Cruise/Idle/PTO mode.

After the kickout, review the status parameter on the electronic service tool. The status parameter for the kickout indicates the cause. This must be performed before the ignition key switch is turned OFF. It is important to remember that the parameter will only indicate the last kickout since the ECM has been powered by the input of the ignition key switch.

This parameter is blank when the ECM is first powered up. If this parameter is blank, "No Occurrence" is indicated. This parameter remains blank until the ECM detects the use of the Cruise/Idle/PTO Mode. Also, this parameter remains blank until the ECM detects the disengagement of the Cruise/Idle/PTO Mode. Refer to Tables 195, 196, 197, and 198 in order to interpret the status screen kickout status parameter.

The following Kickout Status parameters are available:

- "Cruise Kickout"
- "Idle Kickout"
- "PTO Kickout"
- "Fast Idle Kickout"

Table 195

Table For The Cruise Control Kickout Status Screen On The Electronic Service Tool		
Electronic Service Tool	Meaning or Possible Cause	Troubleshooting
“Vehicle Speed < Limit”	Intermittent vehicle speed signal or lost vehicle speed signal.	Refer to Troubleshooting, “Vehicle Speed Circuit - Test”.
“Switch Turned Off”	The Cruise/Idle On/Off switch is turned OFF or the switch circuit has an open circuit condition.	Refer to Troubleshooting, “Cruise Control Switch Circuit - Test”.
“Cruise Control PAUSE Switch”	The cruise pause switch is depressed or there is an illegal message on the J1939 data link.	Refer to Troubleshooting, “Powertrain Data Link Circuit - Test”.
“Brake Pedal Depressed”	The service brake pedal is depressed or the service brake switch circuit 2 has a short circuit condition.	Proceed with this test procedure.
“Clutch Pedal Depressed”	The clutch pedal is depressed or the clutch pedal switch circuit has an open circuit condition. Also, the switch could be incorrectly adjusted.	Refer to Troubleshooting, “Clutch Pedal Position Switch Circuit - Test”.
“Neutral”	The transmission is not in gear or the transmission switch circuit has a short circuit condition.	Refer to Troubleshooting, “Neutral Switch Circuit - Test”.
“Bad Vehicle Speed”	Vehicle speed signal is erratic or intermittent.	Refer to Troubleshooting, “Vehicle Speed Circuit - Test” if a problem with the signal exists.
“PTO Switch On”	The PTO On/Off switch is turned ON or the PTO On/Off switch circuit has a short circuit condition.	Refer to Troubleshooting, “PTO Switch Circuit - Test”.
“Set Switch Timeout”	The Set/Resume switch was held in the SET position for more than 15 seconds (Basic) or there is a short circuit in the switch circuit.	Cruise control cannot be set until the cruise control on/off switch is turned to the OFF position and then turned to the ON position again. If the circuit for the set switch is suspected, proceed with this test procedure.
“Resume Switch Timeout”	The Set/Resume switch was held in the SET position for more than 15 seconds (Basic) or there is a short circuit in the switch circuit.	Cruise control cannot be set until the cruise control on/off switch is turned to the OFF position and then turned to the ON position again. If the circuit for the resume switch is suspected, proceed with this test procedure.
“No Occurrence” or “Not Kicked Out”	Cruise control has not been enabled since the ECM has been powered up.	Drive the vehicle in cruise in order to create the problem again.

Table 196

Table For The Idle Kickout Status Screen On The Electronic Service Tool		
Electronic Service Tool	Meaning or Possible Cause	Troubleshooting
“No Engine Speed”	Intermittent engine speed signal or lost engine speed signal.	Refer to Troubleshooting, “Engine Speed/Timing Circuit - Test”.
“Switch Turned Off”	The Cruise/Idle On/Off switch is turned OFF or the switch circuit has an open circuit condition.	Refer to Troubleshooting, “Cruise Control Switch Circuit - Test”.
“Cruise Control PAUSE Switch”	The cruise pause switch is depressed or there is an illegal message on the J1939 data link.	Refer to Troubleshooting, “Powertrain Data Link Circuit - Test”.
“Brake Pedal Depressed”	The service brake pedal is depressed or the service brake switch 2 circuit has a short circuit condition.	Proceed with the test procedure.
“Clutch Pedal Depressed”	The clutch pedal is depressed or the clutch pedal switch circuit has an open circuit condition. Also, the switch could be incorrectly adjusted.	Refer to Troubleshooting, “Clutch Pedal Position Switch Circuit - Test”.
“Vehicle Speed ≥ Limit”	The vehicle speed has exceeded the Idle Vehicle Speed Limit or the vehicle speed signal is erratic or intermittent.	Refer to Troubleshooting, “Vehicle Speed Circuit - Test” if a problem with the signal exists.
“Neutral”	The transmission is not in neutral or the transmission neutral switch circuit has an open circuit condition.	Refer to Troubleshooting, “Neutral Switch Circuit - Test”.
“PTO Switch On”	The PTO On/Off switch is turned ON or the PTO On/Off switch circuit has a short circuit condition.	Refer to Troubleshooting, “PTO Switch Circuit - Test”.
“No Occurrence” or “Not Kicked Out”	Idle has not been enabled since the ECM has been powered up.	Operate the vehicle in the Idle mode in order to create the problem again.

Table 197

Fast Idle Kickout Status Table		
Electronic Service Tool	Meaning or Possible Cause	Troubleshooting
“No Engine Speed”	Intermittent engine speed signal or lost engine speed signal.	Refer to Troubleshooting, “Engine Speed/Timing Circuit - Test”.
“Switch Turned Off”	The Fast Idle On/Off switch is turned OFF or the switch circuit has an open circuit condition.	Refer to Troubleshooting, “Cruise Control Switch Circuit - Test”.
“Cruise Control PAUSE Switch”	The cruise pause switch is depressed or there is an illegal message on the J1939 data link.	Refer to Troubleshooting, “Powertrain Data Link Circuit - Test”.
“Brake Pedal Depressed”	The service brake pedal is depressed or the service brake switch 2 circuit has a short circuit condition.	Proceed with the test procedure.
“Clutch Pedal Depressed”	The clutch pedal is depressed or the clutch pedal switch circuit has an open circuit condition. Also, the switch could be incorrectly adjusted.	Refer to Troubleshooting, “Clutch Pedal Position Switch Circuit - Test”.
“Vehicle Speed \geq Limit”	The vehicle speed has exceeded the Idle Vehicle Speed Limit or the vehicle speed signal is erratic or intermittent.	Refer to Troubleshooting, “Vehicle Speed Circuit - Test” if a problem with the signal exists.
“Neutral”	The transmission is not in neutral or the transmission neutral switch circuit has an open circuit condition.	Refer to Troubleshooting, “Neutral Switch Circuit - Test”.
“No Occurrence” or “Not Kicked Out”	Fast Idle set speed has not been exited since the ECM has been powered up.	Operate the vehicle in the Idle mode in order to create the problem again.

Table 198

Table For The PTO Kickout Status Screen On The Electronic Service Tool		
Electronic Service Tool	Meaning or Possible Cause	Troubleshooting
No Engine Speed	Intermittent engine speed signal or lost engine speed signal.	Refer to Troubleshooting, “Speed/Timing Circuit - Test”.
Switch Turned Off	The PTO On/Off switch is turned OFF or the switch circuit has an open circuit condition.	Refer to Troubleshooting, “Clutch Pedal Position Switch Circuit - Test”.
“Brake Pedal Depressed”	The service brake pedal is depressed or the service brake switch circuit has an open circuit condition.	Proceed with the test procedure.
“Clutch Pedal Depressed”	The clutch pedal is depressed or the clutch pedal switch circuit has an open circuit condition. Also, the switch could be incorrectly adjusted.	Refer to Troubleshooting, “Clutch Pedal Position Switch Circuit - Test”.
Vehicle Speed \geq Limit	The vehicle speed has exceeded the PTO Vehicle Speed Limit or the vehicle speed signal is erratic or intermittent.	Refer to Troubleshooting, “Vehicle Speed Circuit - Test” if a problem with the signal exists.
Neutral	The transmission is not in neutral or the transmission neutral switch circuit has an open circuit condition.	Refer to Troubleshooting, “Neutral Switch Circuit - Test”.
“No Occurrence” or “Not Kicked Out”	The PTO has not been enabled since the ECM has been powered up.	Operate the vehicle in the PTO mode in order to create the problem again.

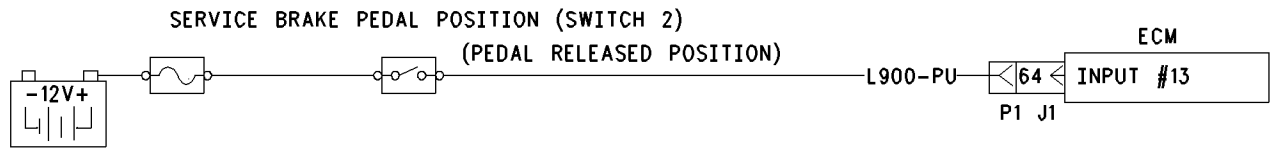

Illustration 169

g00770825

Test Step 1. Determine the Type of Problem.

- A. Connect the electronic service tool to the data link connector.
- B. Turn the ignition key switch to the ON position.
- C. If the vehicle will not allow setting a cruise speed, an idle speed or a PTO speed, check the following Customer Parameters:

Cruise Control Parameters

- “Low Cruise Control Speed Set Limit”
- “High Cruise Control Speed Set Limit”

Idle Parameters

- “Fast Idle RPM #1”
- “Fast Idle RPM #2”
- “Idle Vehicle Speed Limit”
- “Idle RPM Limit”
- “Top Engine Limit” (TEL)

PTO Parameters

- “PTO Configuration”
- “PTO Vehicle Speed Limit”

- D. Ensure that the vehicle is not experiencing a problem due to one of these parameters. Refer to Troubleshooting, “Customer Specified Parameters” for a description of the parameters, if necessary.
- E. Check the electronic service tool status screen that indicates the last cause of a kickout for one of the following items:
 - Cruise control kickout
 - Idle kickout
 - Fast idle kickout

- PTO kickout

Refer to Tables 195, 196, 197, and 198 for the meaning of the status parameter.

Expected Result:

The problem is due to a parameter setting or the problem is due to a normal kickout.

Results:

- Yes – Explain the proper operation of system to the driver. **STOP.**
- No

Repair: Refer to Tables 195, 196, 197, and 198 for recommended troubleshooting.

If a problem is still suspected with the circuit for the service brake pedal position (switch 2), perform the following procedure:

Proceed to Test Step 2.

Test Step 2. Inspect Electrical Connectors and Wiring.

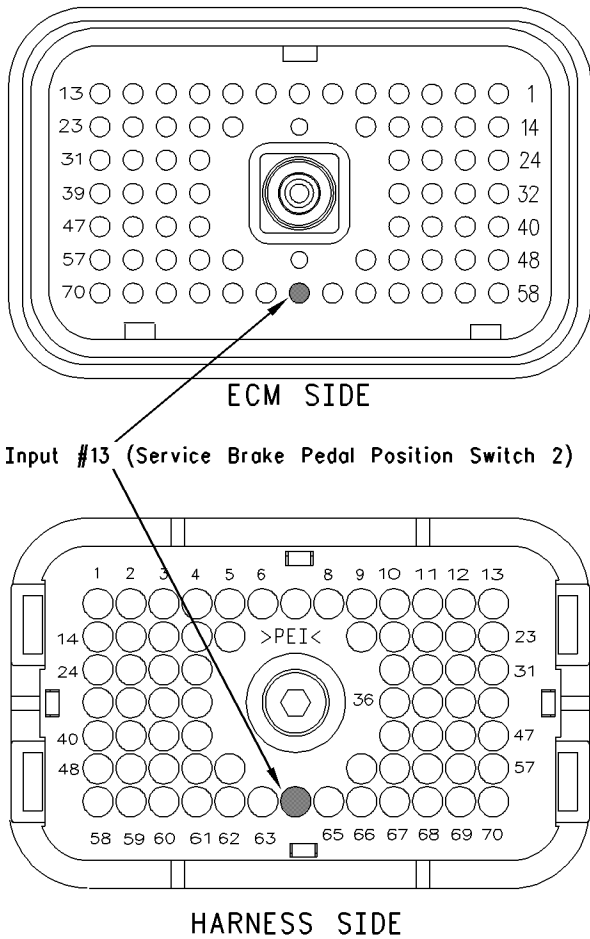

Illustration 170

g00770850

A. Thoroughly inspect ECM vehicle harness connector J1/P1, the firewall bulkhead connector and the terminal 64 (service brake pedal position (switch 2)).

Refer to Troubleshooting, “Electrical Connectors - Inspect” for details.

B. Perform a 45 N (10 lb) pull test on each of the wires in the ECM connector that are associated with the switches.

Refer to Illustration 170.

C. Check the ECM connector (allen head screw) for the proper torque of 6.0 N·m (55 lb in).

D. Check the harness and wiring for abrasion and pinch points from the sensor to the ECM.

Expected Result:

All connectors, pins and sockets should be completely coupled and/or inserted and the harness and wiring should be free of corrosion, abrasion or pinch points.

Results:

- **OK** – Proceed to Test Step 3.
- **Not OK**

Repair: Perform the following repair:

Repair the connectors or wiring and/or replace the connectors or wiring. Ensure that all of the seals are properly in place and ensure that the connectors are completely coupled.

Verify that the repair eliminates the problem.

STOP.

Test Step 3. Check the Service Brake Pedal Switch 2 Status on the Electronic Service Tool.

Table 199

Table for Status of the Service Brake Pedal Position		
Switch Position or Pedal Position	Status	Circuit
The Service Brake Pedal is DEPRESSED.	OFF	Open
The Service Brake Pedal is RELEASED.	ON	Closed

A. Access the electronic service tool status screen.

B. Turn the ignition key switch to the ON position.

C. Start the engine. Ensure that the air system is charged if the vehicle is equipped with air brakes. Depress the service brake while the status of the service brake pedal position (switch 2) is being observed. Also, release the service brake while the status of the service brake pedal position (switch 2) is being observed.

Refer to Table 199 for the status of the switch or for the status of the pedal position.

Note: If the status indicates “Not Installed”, check the programming of the “Transmission Style”. This parameter must be programmed to “Automatic Option 2”, “Automatic Option 3”, “AT/MT/HT Option 2”, or “AT/MT/HT Option 3”.

Expected Result:

The switch status changes per the information in Table 199.

Results:

- **Yes** – The switch is operating normally. **STOP.**
- **Intermittent Problem Suspected** – Proceed to Test Step 4.
- **No** – The ECM is not reading the switch status change. Proceed to Test Step 5.

Test Step 4. Operate the Vehicle and Check the Kickout Status Parameter.

A. For an intermittent cruise control kickout, talk to the driver in order to determine the conditions when the kickout occurs. Topics of examination could be the following examples:

- specific speed
- road conditions
- weather conditions

Take the vehicle for a road test in order to duplicate these conditions and set the cruise control. Operate the vehicle in cruise control until the problem reoccurs.

B. For an intermittent idle kickout, talk to the driver in order to determine the conditions when the kickout occurs. A topic of examination could be the specific engine rpm.

Start the engine. Duplicate these conditions and set the idle rpm. Operate the vehicle in idle until the problem reoccurs.

Note: The electronic service tool status screen will only indicate the last kickout. The electronic service tool status screen will lose this information if the ignition key switch is turned off.

C. Connect the electronic service tool and check the status screen for the last cause of the kickout. Refer to Tables 195, 196, 197, and 198 for an explanation of the status parameter.

D. If the electronic service tool status screen is blank, then either there was no kickout of the cruise control, or the power to the ECM was turned OFF before the information could be read. Repeat this test step.

Note: An electronic service tool status screen that is blank indicates “No Occurrence”.

Expected Result:

RESULT 1 The Electronic Service Tool Kickout Status displays the following result:

- “Brake”

RESULT 2 The Electronic Service Tool Kickout Status displays the following result:

- “Switch Turned Off”

RESULT 3 The Electronic Service Tool Kickout Status displays the following result:

- “Cruise Control PAUSE Switch”

RESULT 4 The Electronic Service Tool Kickout Status displays the following result:

- “Clutch”

RESULT 5 The Electronic Service Tool Kickout Status displays the following result:

- “Vehicle Speed < Limit”
- “Bad Vehicle Speed”
- “Vehicle Speed ≥ Limit”

RESULT 6 The Electronic Service Tool Kickout Status displays the following result:

- “PTO Switch ON”

RESULT 7 The Electronic Service Tool Kickout Status displays the following result:

- “Neutral”

RESULT 8 The Electronic Service Tool Kickout Status displays the following result:

- “No Engine Speed”

RESULT 9 The Electronic Service Tool Kickout Status displays the following result:

- “Ser Switch Timeout”
- “Resume Switch Timeout”

Results:

- **Result 1** – Proceed to Test Step 5.
- **Result 2**

Repair: Perform the following diagnostic procedure:

Troubleshooting, "Cruise Control Switch Circuit - Test"

STOP.

● **Result 3**

Repair: Perform the following diagnostic procedure:

Troubleshooting, "Powertrain Data Link Circuit - Test"

STOP.

● **Result 4**

Repair: Perform the following diagnostic procedure:

Troubleshooting, "Clutch Pedal Position Switch Circuit - Test"

STOP.

● **Result 5**

Repair: Perform the following diagnostic procedures:

Troubleshooting, "Vehicle Speed and Speedometer Circuit - Test"

STOP.

● **Result 6**

Repair: Perform the following diagnostic procedure:

Troubleshooting, "PTO Switch Circuit - Test"

STOP.

● **Result 7**

Repair: Perform the following diagnostic procedure:

Troubleshooting, "Neutral Switch Circuit - Test"

STOP.

● **Result 8**

Repair: Perform the following diagnostic procedure:

Troubleshooting, "Engine Speed/Timing Sensor Circuit - Test"

STOP.

● **Result 9**

Repair: Perform the following diagnostic procedure:

Troubleshooting, "Cruise Control Switch Circuit - Test".

STOP.

Test Step 5. Check the Switch Circuit.

Table 200

Table for Status of Service Brake Pedal Position (Switch 2)		
Condition of Switch Circuit	Switch Status	Circuit
Terminal 64 is Open.	ON	Open
Terminal 64 connected to terminal 5.	OFF	Closed

- A.** Turn the ignition key switch to the OFF position.
- B.** Fabricate a jumper wire 100 mm (4 inch) long. Crimp a Deutsch pin to both ends of the wires.
- C.** Disconnect vehicle harness connector P1 from the ECM.
- D.** Connect a breakout T to ECM connector J1 and connect P1 to the breakout T.
- E.** Install the jumper into terminal 64 (service brake pedal position switch 2) of the breakout T. Connect the other end of the jumper to ECM connector P1 terminal 52 (unswitched +battery) of the breakout T.
- F.** Turn the ignition key switch to the ON position.
- G.** Connect an electronic service tool to the cab data link connector.
- H.** Access the electronic service tool status screen.
- I.** While the status of the service brake pedal position (switch 2) is being monitored on the electronic service tool status screen slowly remove the jumper from terminal 64 (unswitched +battery). Now, slowly insert the jumper into the terminal 52 (unswitched +battery).

Refer to Table 200.

Expected Result:

The switch status changes per the information in Table 200.

Results:

- **Yes** – The ECM is functioning properly. Proceed to Test Step 6.
- **No** – The ECM is not functioning properly.

Repair: Perform the following repair:

1. Temporarily connect a test ECM.
2. Remove all jumpers and replace all connectors.
3. Recheck the system for active diagnostic codes.
4. Repeat the test step.
5. If the problem is resolved with the test ECM, reconnect the suspect ECM.
6. If the problem returns with the suspect ECM, replace the ECM.
7. Verify that the repair eliminates the problem.

STOP.

Test Step 6. Insert a Jumper at the Service Brake Pedal Position (Switch 2).

Table 201

Table for Status of the Service Brake Pedal Position (Switch 2)		
Condition of Switch Circuit	Switch Status	Circuit
Service Brake Pedal Position Switch 2 Wires are Disconnected.	OFF	Open
Service Brake Pedal Position Switch 2 Wires Connected.	On	Shorted

- A.** Turn the ignition key switch to the OFF position.
- B.** Ensure that ECM vehicle harness connector J1/P1 is connected.
- C.** Find the switch for the service brake pedal position (switch 2) in the vehicle.
- D.** Disconnect the wires from the switch terminals.
- E.** Turn the ignition key switch to the ON position.
- F.** Connect the electronic service tool to the cab data link connector.
- G.** Access the electronic service tool status screen.

- H.** While the switch status is being monitored on the electronic service tool status screen slowly connect the switch wires and slowly disconnect the switch wires.

Refer to Table 201.

Expected Result:

The switch status changes per the information in Table 201.

Results:

- **Yes**

Repair: Perform the following repair:

Replace the faulty switch.

Verify that the repair eliminates the problem.

STOP.

- **No** – There is a problem in the harness between the switch and the ECM. Proceed to Test Step 7.

Test Step 7. Insert a Jumper at the Bulkhead Connector.

Table 202

Table for Status of the Service Brake Pedal Position (Switch 2)		
Switch Position or Pedal Position	Switch Status	Circuit
Service Brake Pedal Position Switch 2 Wire is Disconnected.	OFF	Open
Service Brake Pedal Position Switch 2 Wire Connected.	ON	Shorted

- A.** Turn the ignition key switch to the OFF position.
- B.** Fabricate a jumper wire 100 mm (4 inch) long. Crimp a Deutsch pin to each end of the wires.
- C.** Find the switch for the terminal for the service brake pedal position (switch 2). Also find the terminal for the sensor common for the +battery in the engine side of the bulkhead connector for the vehicle harness.
- D.** Insert the jumper wire between the two terminals in the engine side of the bulkhead connector.
- E.** Turn the ignition key switch to the ON position.

- F. Connect the electronic service tool to the cab data link connector.
- G. Access the electronic service tool status screen.
- H. While the switch status is being monitored on the electronic service tool status screen alternately remove the jumper wire between the two terminals, and alternately insert the jumper wire between the two terminals.

Refer to Table 202.

Expected Result:

The switch status changes per the information in Table 202.

Results:

- **Yes** – The problem is in the vehicle wiring between the bulkhead connector and the switch.

Repair: Perform the following repair:

Inspect the vehicle wiring and repair the vehicle wiring, as required. If the problem still exists with the wiring, send the vehicle to the OEM dealer.

STOP.

- **No** – The problem is in the vehicle wiring between the bulkhead connector and the ECM.

Repair: Perform the following repair:

Inspect the vehicle wiring and repair the vehicle wiring, as required. If the problem still exists with the wiring, send the vehicle to the OEM dealer.

STOP.

Output 2 is available to connect a relay and/or a solenoid in order to control a starting aid system. The parameter "Starting Aid Output" must be programmed to "Automatic" in order to use output 2 as a starting aid output.

Typical starting aid systems inject ether into the inlet manifold in order to aid starting of the engine during cold weather operation. The output is automatically controlled by the ECM. The reading from the coolant temperature sensor is used to determine if conditions require the use of the starting aid. If a fault condition exists with the circuit for the coolant temperature sensor, the reading from the inlet manifold temperature sensor will be used. The starting aid output will be enabled for a maximum of 30 seconds while the engine is cranking and the temperature reading is below 0 °C (32 °F). The starting aid output will be disabled if the engine speed rises above 500 rpm. The starting aid output will also be disabled if a condition that prevents fuel injection occurs.

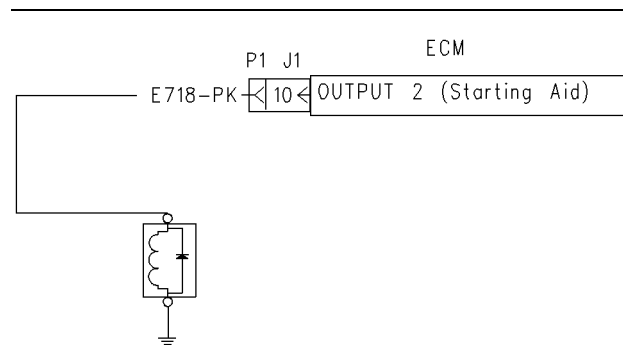

Illustration 171

Schematic for the starting aid circuit

g00838120

i01619084

Starting Aid Output Circuit - Test

SMCS Code: 1456-081

System Operation Description:

Use this procedure under the following situation:

Use this procedure in order to determine if the circuit for the Starting Aid Output is operating properly.

The following background information is related to this procedure:

OCT01 Software

Starting Aid Output

Test Step 1. Inspect Electrical Connectors and Wiring.

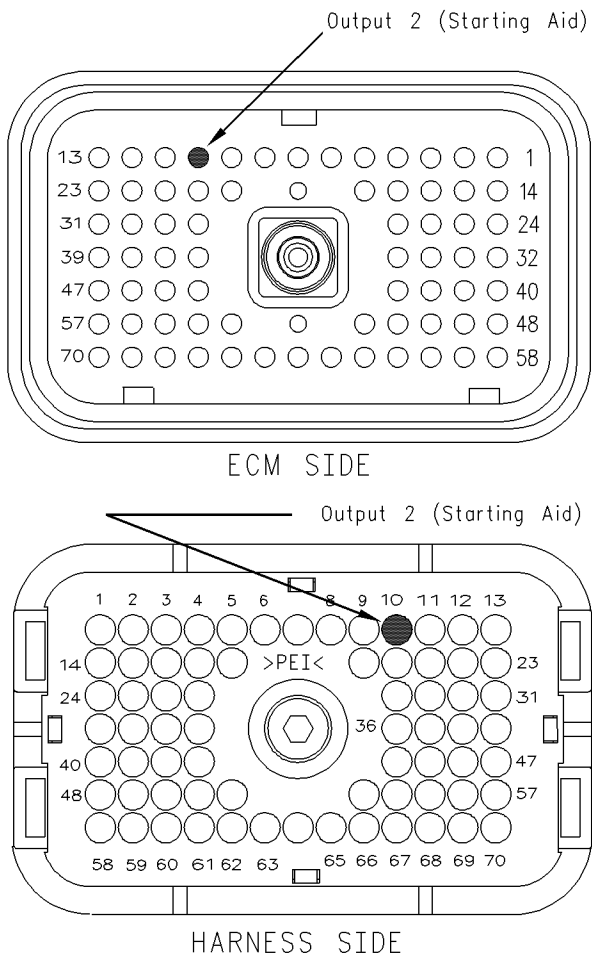

Illustration 172

g00838127

Pin locations for output 2

- A.** Thoroughly inspect ECM vehicle harness connector J1/P1, and the firewall bulkhead connector.

Refer to Troubleshooting, "Electrical Connectors - Inspect" for details.
- B.** Perform a 45 N (10 lb) pull test on terminal 10 in the ECM connector.
- C.** Check the ECM connector (allen head screw) for the proper torque of 6.0 N·m (55 lb in).
- D.** Check the harness and wiring for abrasion and for pinch points from the sensor to the ECM.

Expected Result:

All connectors, pins and sockets should be completely coupled and/or inserted and the harness and wiring should be free of corrosion, abrasion or pinch points.

Results:

- **OK** – Proceed to Test Step 2.
- **Not OK**

Repair: Perform the following repair:

Repair the connectors or wiring and/or replace the connectors or wiring. Ensure that all of the seals are properly in place and ensure that the connectors are completely coupled.

Verify that the repair eliminates the problem.

STOP.

Test Step 2. Use ET to Check the Relay.

- A.** Connect ET to the cab data link connector.
- B.** Turn the ignition key switch to the ON position.
- C.** Access the special test "Starting Aid Output" on ET. The "Starting Aid Output" test will enable output 2 when the test is active.
- D.** Begin the "Starting Aid Output" test and listen for the relay to "click". You may need to be near the engine in order to hear the "click".

Expected Result:

The relay activates when the special test is enabled.

Results:

- **Yes** – The ECM and vehicle components are operating correctly. **STOP.**
- **No** – Proceed to Test Step 3.

Test Step 3. Use ET to Check the ECM.

Illustration 173

g00838135

Breakout T

- A. Connect ET to the cab data link connector.
- B. Turn the ignition key switch to the OFF position.
- C. Disconnect the ECM vehicle harness connector J1/P1.
- D. Connect a breakout T between ECM connectors J1 and P1.
- E. Connect a voltage test lamp to terminal 10 (output 2) and terminal 65 (-battery) of the breakout T.
- F. Turn the ignition key switch to the ON position.
- G. Access the special test "Starting Aid Output" on ET.
- H. Cycle the special test "Starting Aid Output" to "Active" and to "Not Active" and watch the voltage test lamp.
- I. Stop the special test.

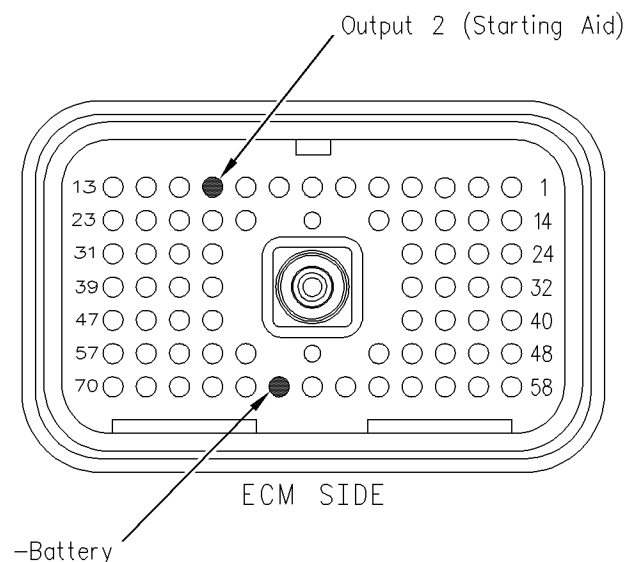
Note: A multimeter can not be used in place of the voltage test lamp when the ECM outputs are being tested.

Expected Result:

The voltage test lamp turns ON when the test is active. The voltage test lamp turns OFF when the test is not active.

Results:

- **Yes** – The ECM is OK. The problem is in the vehicle wiring. Inspect the vehicle wiring and then repair the vehicle wiring. Otherwise, send the vehicle to the OEM dealer for repair. Verify that the original condition is resolved. **STOP**.
- **No** – Temporarily connect a test ECM. Use the "Starting Aid Output Special Test" on ET to check the ECM. If the problem is resolved with the test ECM, install the suspect ECM. If the problem returns with the suspect ECM, replace the ECM. Verify that the repair eliminates the problem. **STOP**.

i01858198

Tachometer Circuit - Test**SMCS Code:** 7462-081**System Operation Description:****Use this procedure under the following situation:**

Use this procedure when all of the following conditions exist:

- The ECM is connected to the tachometer.
- A problem is suspected.

If the vehicle tachometer is driven by the ECM the vehicle tachometer will be connected to the ECM through connector J1/P1:38 and/or J1/P1:39. Some tachometers require only one of the ECM tachometer signal lines to operate while other tachometers may require both of the ECM tachometer signal lines to operate.

The following background information is related to this procedure:

The tachometer circuit consists of the tachometer that is connected to the ECM through connector J1/P1 and associated wiring. The ECM engine speed signal is provided by the crankshaft position sensor. The ECM converts the signal from the crankshaft position sensor into engine rpm in pulses per revolution before the ECM sends a signal to the tachometer. The selection of the pulses per revolution for the tachometer is done through the Customer Programmable Parameter "Tachometer Calibration".

The ECM tachometer signal is programmable from 12.0 to 500.0 pulses per revolution in 0.1 increments. The tachometer must be calibrated identically to this value for proper operation.

The most likely source of a tachometer circuit problem is the vehicle wiring. The second most likely source of a tachometer circuit problem is the tachometer and the least likely source of a tachometer circuit problem is the ECM.

Note: A tachometer may also be driven by the SAE J1587 Data Link. If the engine ECM communicates with the electronic service tool and the instrument cluster uses the signal from the SAE J1587 data link, the problem is in one of two locations. Either the problem is in the wiring from the ECM to the dash, or the problem is in the dash. The vehicle should be referred to the OEM dealer for service.

Note: Do not disturb the camshaft position sensor and the crankshaft position sensor in order to troubleshoot a tachometer circuit problem. If there is a problem that is associated with the sensors, refer to Troubleshooting, "Engine Speed/Timing Sensor Circuit - Test". Any problem that is associated with the camshaft position sensor and the crankshaft position sensor will be apparent because of engine operation with a diagnostic code that is present. There are no diagnostic codes that are associated with the tachometer circuit.

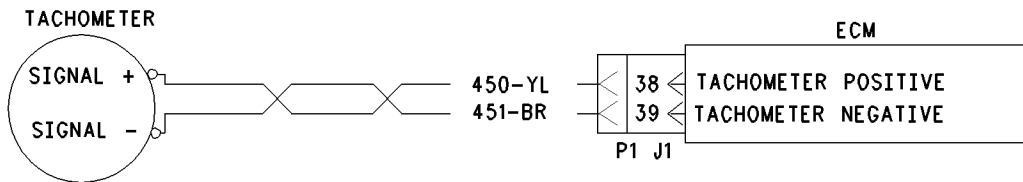

Illustration 174

g00649121

Schematic No. 1 for tachometer

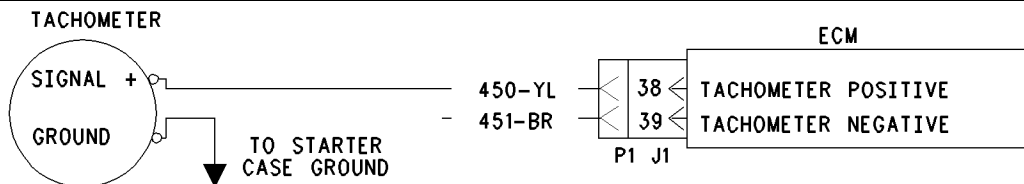

Illustration 175

g00649123

Schematic No. 2 for tachometer

Test Step 1. Inspect Electrical Connectors and Wiring.

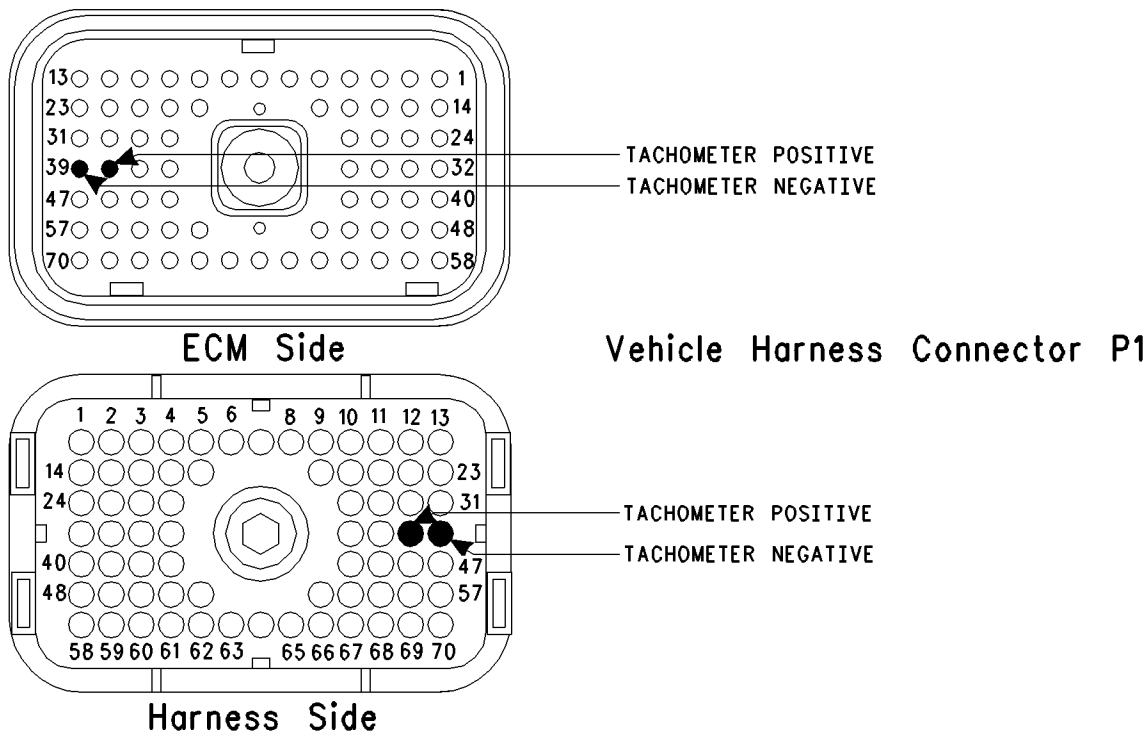

Illustration 176

g00649124

Terminal locations for ECM

- A.** Thoroughly inspect ECM vehicle harness connector J1/P1, the firewall bulkhead connector, and the terminals for the tachometer in the connectors. Refer to Troubleshooting, “Electrical Connectors - Inspect” for details.
- B.** Perform a 45 N (10 lb) pull test on each of the wires in the ECM connector that are associated with the terminals for the tachometer:
 - P1:38
 - P1:39

Refer to Illustration 176.
- C.** Check the ECM connector (allen head screw) for the proper torque of 6.0 N·m (55 lb in).
- D.** Check the harness and wiring for abrasion and pinch points from the battery to the ECM.

Expected Result:

All connectors, pins and sockets should be completely coupled and/or inserted and the harness and wiring should be free of corrosion, abrasion or pinch points.

Results:

- OK – Proceed to Test Step 2.
- Not OK

Repair: Perform the following repair:

1. Repair the connectors or wiring and/or replace the connectors or wiring. Ensure that all of the seals are properly in place and ensure that the connectors are completely coupled.
2. Verify that the repair eliminates the problem.

STOP.

Test Step 2. Check the ECM Connection to the Tachometer.

- A.** Inspect ECM connector J1/P1. Verify that the connections are present at P1:39 Tachometer- and/or P1:38 Tachometer+.

Note: Some of the tachometers require only one signal line to be connected. Either of the ECM terminals can be used for this type of tachometer. The other wire should be left disconnected. If both wires are connected, and one indicates an open circuit, repair this line.

Expected Result:

Wires are connected to the ECM terminals for the tachometer, P1:39 (Tachometer-) and/or P1: 38 (Tachometer+).

Results:

- **OK** – The ECM is providing the signal for the tachometer. Proceed to Test Step 3.
- **Not OK** – The ECM is not connected in order to supply the signal to the tachometer.

Repair: Send the vehicle to the OEM dealer in order to repair the tachometer circuit.

STOP.

Test Step 3. Use an Electronic Service Tool to Check the ECM Tachometer Signal.

- A. Connect the electronic service tool at the cab data link connector.
- B. Turn the ignition key switch to the ON position.
- C. Access the Tachometer Special Test. Access the following display screens in order:
 - “Diagnostics”
 - “Diagnostic Tests”
 - “Special Test”
- D. While the dash tachometer is being monitored, begin the test.

Expected Result:

RESULT 1 The dash tachometer indicates approximately 1500 ± 150 rpm and the dash tachometer is stable.

RESULT 2 The tachometer does not indicate an engine rpm or the tachometer is erratic.

RESULT 3 The tachometer rpm is stable but the tachometer rpm is not within 50 rpm of 1500 rpm.

Results:

- **Result 1** – The ECM and the tachometer are OK. STOP.
- **Result 2** – The engine rpm is not indicated or the engine rpm is erratic. Proceed to Test Step 4.

- **Result 3** – The engine rpm is not within 50 rpm of 1500 rpm. Proceed to Test Step 5.

Test Step 4. Check the ECM Tachometer Signal.

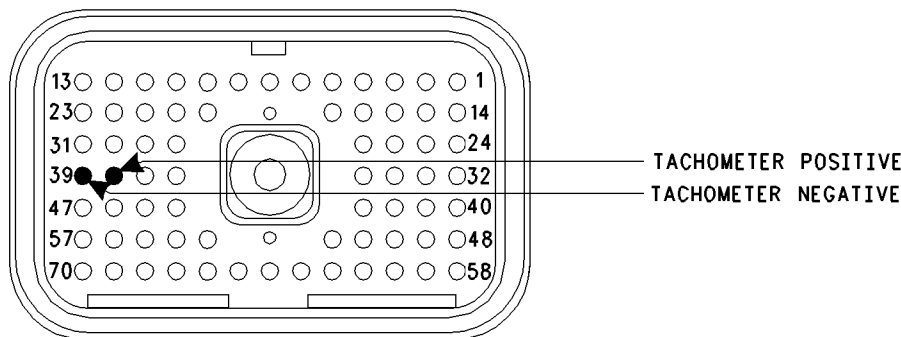

Illustration 177

g00649125

ECM Breakout T-connector

Note: Performing certain steps within this procedure requires the use of a multimeter that is capable of measuring a PWM Duty Cycle.

- A.** Disconnect ECM vehicle harness connector J1/P1.
- B.** Connect a breakout T to ECM vehicle harness connector P1.
- C.** Fabricate two jumper wires 100 mm (4 inch) long. Crimp a Deutsch Pin to one end of each wire.
- D.** Insert one of the jumper wires into P1:39 (Tachometer-) of the breakout T and insert the other jumper wire into P1:38 (Tachometer+) of the Breakout T.

Refer to Illustration 177.

- E.** Access the Tachometer Special Test. Access the following display screens in order:
 - "Diagnostics"
 - "Diagnostic Tests"
 - "Special Test"
- F.** Attach one of the multimeter leads to the jumper wire from P1:38.
- G.** Attach the other multimeter lead to the jumper wire from P1:39.
- H.** While the Tachometer Special Test is being run, observe the reading on the multimeter.

Expected Result:

The multimeter indicates a duty cycle from 30 to 70 percent from each of the terminals for the tachometer while the engine is running.

Results:

- **OK** – The ECM tachometer output is OK. Connect the ECM vehicle harness connector J1 to P1. Proceed to Test Step 6.
- **Not OK** – The duty cycle is out of the range.

Repair: Perform the following repair:

1. Temporarily connect a test ECM.
2. Remove all jumpers and replace all connectors.
3. Recheck the system for active diagnostic codes.
4. Repeat the test step.
5. If the problem is resolved with the test ECM, reconnect the suspect ECM.
6. If the problem returns with the suspect ECM, replace the ECM.
7. Verify that the repair eliminates the problem.

STOP.

Test Step 5. Inspect the Tachometer Calibration.

- A.** Determine the tachometer engine speed calibration setting in pulses per revolution. You may be required to contact the OEM dealer or you may be required to send the vehicle to the OEM dealer for this information.
- B.** Connect the electronic service tool at the cab data link connector.
- C.** Check the "Tachometer Calibration" parameter on the Customer Parameters screen.

Expected Result:

The “Tachometer Calibration” matches the ECM tachometer calibration.

Results:

- OK – The tachometer is correctly calibrated.

Repair: Perform the following repair:

1. If the tachometer is correctly calibrated but the tachometer does not work, replace the tachometer or send the tachometer to the OEM dealer for repair.
2. Verify that the repair eliminates the problem.

STOP.

- Not OK – The tachometer is not correctly calibrated.

Repair: Perform the following repair:

1. Calibrate the tachometer in order to match the ECM.
 - a. If the tachometer calibration is known and the tachometer calibration is within 12.0 to 500.0 pulses per revolution, change the Customer Programmable Parameter of the ECM “Tachometer Calibration” in order to match the tachometer.
2. Verify that the repair eliminates the problem.

STOP.

Test Step 6. Check the ECM Connection to the Tachometer.

- A. Find the tachometer signal connections to the tachometer.
- B. Disconnect the wires from the ECM to the tachometer at the ECM connector and at the tachometer.

Refer to Illustration 177.

- C. Check for continuity through the wires to the ECM connector P1:39 (Tachometer-) and P1:38 (Tachometer+).

Note: Some of the tachometers require only one signal line to be connected. Either of the ECM terminals can be used for this type of tachometer. The other wire should be left disconnected. If both wires are connected, and one indicates an open circuit, repair this line.

Expected Result:

The wires from the ECM to the tachometer are undamaged.

Results:

- OK – The wiring is OK. Proceed to Test Step 7.
- Not OK – The wiring is damaged.

Repair: Perform the following repair:

Either repair the wiring or send the vehicle to the OEM dealer. Verify that the repair eliminates the problem.

STOP.

Test Step 7. Check the Tachometer Battery Supply Voltage.

- A. Connect the tachometer lines to the ECM and the tachometer.
- B. Check the +Battery connections and the –Battery connections to the tachometer. Include the fuses and the circuit protection.

Expected Result:

The tachometer is receiving the correct battery supply voltage.

Results:

- OK – The battery supply voltage is OK.

Repair: Perform the following repair:

If the tachometer is receiving the correct battery supply voltage but the tachometer does not work, replace the tachometer or send the tachometer to the OEM dealer for repair.

STOP.

- Not OK – The battery supply voltage is incorrect.

Repair: Perform the following repair:

1. Repair the wiring for the battery supply.
2. Verify that the repair eliminates the problem.

STOP.

i01611424

Transmission (AT/MT/HT) Relay Circuit - Test

SMCS Code: 1901-081

System Operation Description:

Use this procedure under the following situation:

Use this procedure to determine if the AT/MT/HT transmission interface relay (output #7) is operating correctly.

The following background information is related to this procedure:

Allison AT/MT/HT transmissions require an input from the ECM to regulate the transmission shifting. The ECM monitors various operating parameters in order to determine if the transmission should use closed throttle shift modulation or full throttle shift modulation. Programming the "Transmission Style" parameter to "AT/MT/HT Option1", "AT/MT/HT Option2", "AT/MT/HT Option3", or "AT/MT/HT Option4" activates ECM Output #7 in order to control a shift interface relay that is connected to the Allison transmission.

Transmission Style

For engines that have a Full Feature ECM, the "Transmission Style" must be programmed to one of the AT/MT/HT options in order for Output #7 to control the AT/MT/HT transmission relay. For the "Basic (GM) System", Output #7 is always available.

Note: The ECM does not communicate with the Allison AT/MT/HT Transmission through a data link.

Cruise Control or Vehicle Speed Limiting is NOT active.

The AT/MT/HT transmission interface relay will be disabled if any of the following conditions occur:

- The engine is not running.
- The transmission is in neutral and the speed of the vehicle is less than 24 km/h (15 mph) (NOV99 and older Personality Modules).
- The accelerator pedal position is less than 65 percent of the programmed value. Refer to the note below.

Note: JUL99 and newer Personality Modules have a programmable "AT/MT/HT Part Throttle Shift Speed" parameter that provides three different shift modulation settings for the transmission. The "Low" setting will disable the relay below 65 percent throttle, the "Medium" setting below 55 percent throttle, and the "High" setting below 45 percent throttle.

The AT/MT/HT transmission interface relay will be enabled under any the following conditions:

- The engine is running.
- The transmission is in gear or the speed of the vehicle is greater than 24 km/h (15 mph) (NOV99 and older Personality Modules).
- The accelerator pedal position is greater than 80 percent of the programmed value. Refer to the note below.

Note: JUL99 and newer Personality Modules have a programmable "AT/MT/HT Part Throttle Shift Speed" parameter that provides three different shift modulation settings for the transmission. The "Low" setting will enable the relay above 80 percent throttle, the "Medium" setting above 70 percent throttle, and the "High" setting above 60 percent throttle.

Cruise Control or Vehicle Speed Limiting is active.

The AT/MT/HT transmission interface relay will be disabled when all of the following conditions occur:

- The speed of the vehicle is greater than 2 km/h (1 mph) of the cruise set speed or the vehicle speed limit.
- The load factor is less than 75 percent.
- The engine speed is greater than 2000 rpm.

The transmission interface relay will be enabled when the load factor is greater than 98 percent.

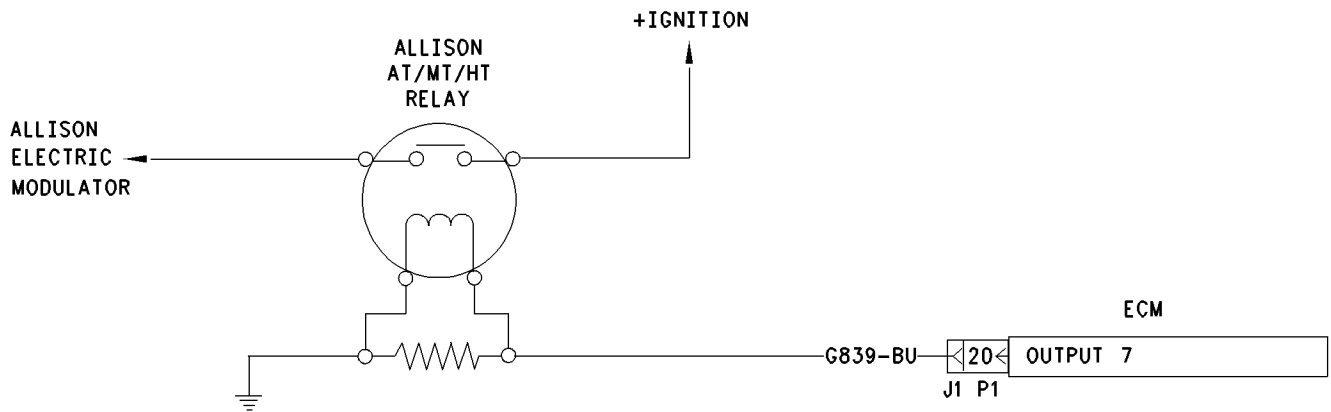

Illustration 178
Schematic for the AT/MT/HT Transmission Relay

g00729187

Test Step 1. Check Electrical Connectors and Wiring.

- A. Thoroughly inspect ECM connectors J1/P1 and the firewall bulkhead connector. Refer to Troubleshooting, "Electrical Connectors - Inspect" for details.
- B. Perform a 45 N (10 lb) pull test on each of the wires that go to P1:20 or P1:12.
- C. Check the ECM connector (allen head screw) for the proper torque of 6.0 N·m (55 lb in).
- D. Check the harness and wiring for abrasion and pinch points from the sensor to the ECM.

Expected Result:

All connectors, pins and sockets should be completely coupled and/or inserted and the harness and wiring should be free of corrosion, abrasion or pinch points.

Results:

- OK – Proceed to Test Step 2.
- Not OK

Repair: Perform the following repair:

Repair the connectors or wiring and/or replace the connectors or wiring. Ensure that all of the seals are properly in place and ensure that the connectors are completely coupled.

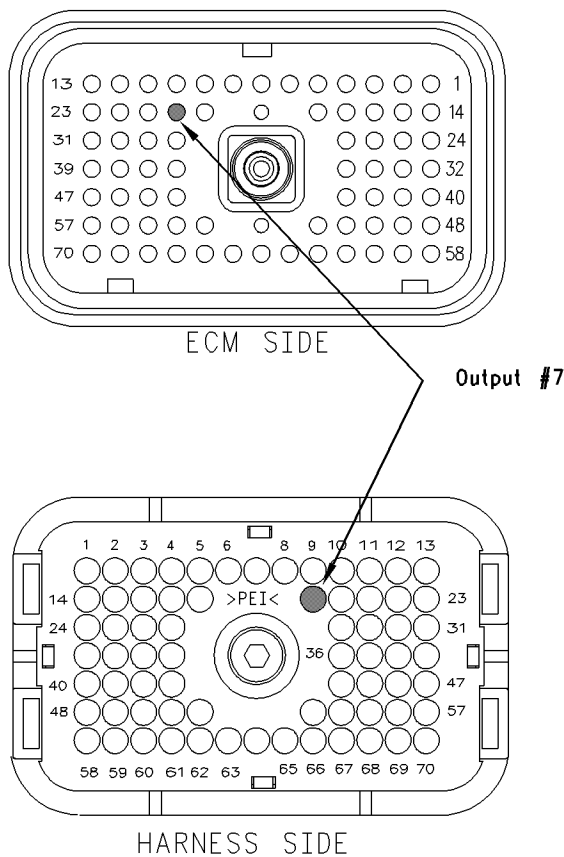

Illustration 179
ECM terminal

g00729188

Verify that the repair eliminates the problem.

STOP.

Test Step 2. Use ET to Check the Accelerator Pedal Position Sensor.

- A. Ensure that the cruise control switch is off.
- B. Connect ET to the cab data link connector.
- C. Turn the ignition key switch to the ON position.
- D. Use the following procedure to check the accelerator pedal position sensor:
 - a. Monitor the duty cycle of the throttle sensor on ET. Access the display screens in the following order:
 - “Service”
 - “Calibrations”
 - “Throttle Position”
 - b. While the duty cycle is being monitored on ET, depress the accelerator pedal and release the accelerator pedal. Repeat this action several times.

Expected Result:

The duty cycle of the accelerator pedal position sensor is between 3 percent and 100 percent.

Results:

- OK – Proceed to Test Step 3.
- Not OK

Repair: Perform the following diagnostic procedure:

Troubleshooting, “Accelerator Pedal (Throttle) Position Sensor Circuit - Test”

STOP.

Test Step 3. Use ET to Check the Solenoids and the Relays.

- A. Connect ET to the cab data link connector.
- B. Turn the ignition key switch to the ON position.
- C. Access the “AT/MT/HT XMission Interface Test” through the following menus:
 - “Diagnostics”
 - “Diagnostic Tests”

- “Special Tests”

Note: The “Transmission Style” must be programmed to “AT/MT/HT Option 1”, “AT/MT/HT Option 2”, “AT/MT/HT Option 3”, or “AT/MT/HT Option 4” for the “AT/MT/HT XMission Interface Test” to be available. This will allow output 7 to control the AT/MT/HT transmission relay.

- D. Begin the “AT/MT/HT XMission Interface Test” while you listen for the solenoids to click. You may need to be closer to the transmission in order to hear the click of the relay.

Expected Result:

The relay activates when the test is enabled.

Results:

- Yes – The ECM is functioning properly at this time. STOP.
- No – Proceed to Test Step 4.

Test Step 4. Use ET to Check the ECM.

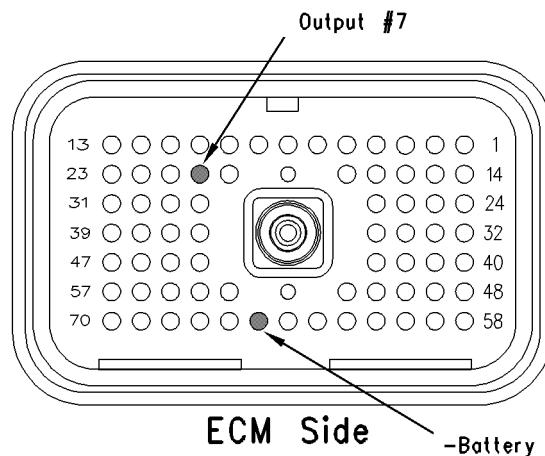

Illustration 180
Breakout T

g00770060

- A. Turn the ignition key switch to the OFF position.
- B. Disconnect the ECM engine harness connector J1/P1.
- C. Connect a breakout T to the ECM connector J1/P1.
- D. Connect a voltage test lamp to terminal 20 (Output 7) and terminal 65 (-Battery) of the breakout T.

- E. Turn the ignition key switch to the ON position.
- F. Access the “AT/MT/HT XMission Interface Test” through the following menus:
 - “Diagnostics”
 - “Diagnostic Tests”
 - “Special Tests”

Note: The “Transmission Style” must be programmed to “AT/MT/HT Option 1”, “AT/MT/HT Option 2”, “AT/MT/HT Option 3”, or “AT/MT/HT Option 4” for the “AT/MT/HT XMission Interface Test” to be available. This will allow output 7 to control the AT/MT/HT transmission relay.

- G. While the voltage test lamp is being observed, cycle the special test on and off.
- H. Stop the special test.

Expected Result:

The voltage test lamp behaves in the following manner:

- The voltage test lamp turns on when the test is active.
- The voltage test lamp turns off when the test is not active.

Results:

- **Yes** – The ECM is OK. There is a problem in the harness.

Repair: Perform the following repair:

Repair the engine harness or replace the engine harness. Verify that the repair eliminates the problem.

STOP.

- **No** – Temporarily connect a test ECM. Repeat this test step. If the problem is resolved with the test ECM, reconnect the suspect ECM. If the problem returns with the suspect ECM, replace the ECM.

Repair: Perform the following repair:

1. Temporarily connect a test ECM.
2. Remove all jumpers and replace all connectors.
3. Recheck the system for active diagnostic codes.

4. Repeat the test step.
5. If the problem is resolved with the test ECM, reconnect the suspect ECM.
6. If the problem returns with the suspect ECM, replace the ECM.
7. Verify that the repair eliminates the problem.

STOP.

i01632415

Vehicle Speed and Speedometer Circuit - Test

SMCS Code: 7463-081; 7493-081

System Operation Description:

Use this procedure under the following situation:

Use this procedure to troubleshoot the system only under the following conditions:

- There is an active diagnostic code.
- There is an easily repeated diagnostic code that is associated with the vehicle speed circuit.

Refer to Troubleshooting, “Vehicle Speed Circuit - Calibrate” if the vehicle speed is being calibrated in ppm (pulses per mile) or PPKM (pulses per kilometer).

The following background information is related to this procedure:

The vehicle speed circuit consists of the vehicle speed source and associated wiring. The vehicle speed source is installed by the vehicle OEM. Usually, a sensor reads movement of the transmission output shaft from the teeth on a chopper wheel. The ECM converts the signal from the vehicle speed source into vehicle speed for the following functions:

- Cruise control
- Fast idle
- Idle speed control
- Progressive shift
- Speedometer
- PTO operation

- Vehicle speed limiting
- Idle shutdown
- Operation of the air inlet heater
- Secure idle theft deterrent
- Trip data
- Maintenance data

To begin troubleshooting a vehicle speed problem, the following information must be determined:

The problem is electrical or the problem is a calibration problem.

Electrical problems would be an erratic speed signal or no speed signal. A calibration problem would be a stable ECM speed, but an inaccurate ECM speed. Another calibration problem would be a stable Speedometer speed, but an inaccurate speedometer speed.

If the problem is related to vehicle speed calibration, refer to Troubleshooting, "Vehicle Speed Circuit - Calibration" for calibrating the vehicle speed in PPKM (pulses per kilometer) or ppm (pulses per mile). The ECM speedometer output signal is set to 18,600 PPKM (30,000 ppm) for most configurations. For "GM Truck Manufacturer" configurations with SEPO0 or newer software, the output of the speedometer is set to 2,485 PPKM (4,000 ppm). The ECM speedometer output signal cannot be changed. All speedometers that are driven by the ECM output (J1/P1 terminal 36 and terminal 37) must match the fixed output of the ECM for proper operation.

The type of vehicle speed sensor that is installed on the vehicle must be determined.

Both single coil magnetic sensors and dual coil magnetic sensors are commonly used. Caterpillar recommends single coil magnetic sensors. Some of the vehicles may provide the vehicle speed through the Transmission ECM.

You must determine if the vehicle speedometer is driven from the ECM.

The ECM can drive the speedometer through the connection to ECM connector J1 terminal 36 (speedometer positive) and/or terminal 37 (speedometer negative).

Note: The ECM may also drive the speedometer by a connection to the J1587 ATA data link, if the instrument cluster is capable of interpreting the signal.

Vehicle Speed Circuit Wiring

The vehicle speed signal is routed directly into the ECM at ECM vehicle harness connector J1/P1 terminal 32 (vehicle speed in positive) and terminal 33 ("vehicle speed in negative").

Speedometer Connection

If the vehicle speedometer is driven by the ECM output, the vehicle speedometer will be connected to the ECM vehicle harness connector J1/P1 terminal 36 and/or terminal 37. Some speedometers require only one of the ECM signal lines to operate. Other speedometers may require both of the ECM signal lines to operate.

Speedometer Special Test

If the vehicle speedometer is driven by ECM output, the speedometer circuit can be checked by using ET. The "55 mph VSP/Speedometer Test" will drive the speedometer to approximately 55 mph under the following conditions:

- The "55 mph VSP/Speedometer Test" is activated.
- The circuit is operating properly.
- The speedometer is operating properly.

Note: While the test is active, the odometer will increment mileage.

Magnetic Sensors

A magnetic pickup will have only two wires if the magnetic pickup is a single coil magnetic sensor. Also, a magnetic pickup will have four wires if the magnetic pickup is a dual coil magnetic sensor. The magnetic pickup sensor does not require a power connection or a ground connection.

Vehicles with Electronic Vehicle Speed Sources

For these vehicles, the vehicle speed signal is provided by an electronic source. The signal is received over a single wire that is connected to ECM vehicle harness connector J1/P1 terminal 32 (vehicle speed in positive). No other connection should be made to this line. A speedometer is an example of a connection that should not be made to this line. For this type of signal, the ECM vehicle harness connector J1/P1 terminal 33 (vehicle speed in negative) should not be connected to the ECM in order to prevent introducing electrical noise into the circuit.

For vehicle speed problems on trucks that are equipped with either of these vehicle speed sources, first inspect the wiring from the electronic source to the engine ECM for open circuits or short circuits.

With SEP00 and newer software, the ECM can be configured to receive vehicle speed information from an Electronic Transmission Control Unit via the J1939 data link. The transmission must be capable of supporting the "J1939 ETC1 Broadcast Message (PGN 61,442 Bytes 2 & 3)". This message provides the speed of the transmission output shaft. This feature requires the hardware for the J1939 data link to be installed in the chassis of the vehicle. This also requires a transmission that is electronically controlled and capable of supporting the necessary J1939 protocol.

When the engine is configured for the J1939 option, the circuit for the ECM vehicle speed input (terminals 32 and 33) will be ignored. The ECM uses the "Vehicle Speed Cal (J1939-Trans)" parameter value in order to calculate vehicle speed. The ECM uses the parameter value and the speed of the output shaft that is received over the J1939 data link to calculate the vehicle speed. The "Vehicle Speed Cal (J1939-Trans)" parameter is based on the revolutions per mile of the output shaft. There are several methods that can be used to arrive at this calibration value. Refer to Troubleshooting, "Vehicle Speed Circuit - Calibrate" for details.

Regardless of the source that is used to determine vehicle speed, the ECM uses the calculated value for the vehicle speed in the same manner to control several features and functions. The diagnostics for vehicle speed function very similarly when either a hard-wired signal is provided to the ECM from a speed sensor, or a message is sent to the ECM via the J1939 data link. If the ECM detects a loss of vehicle speed or a value that is invalid, a fault code will be logged in order to alert the operator or the technician of the presence of a problem.

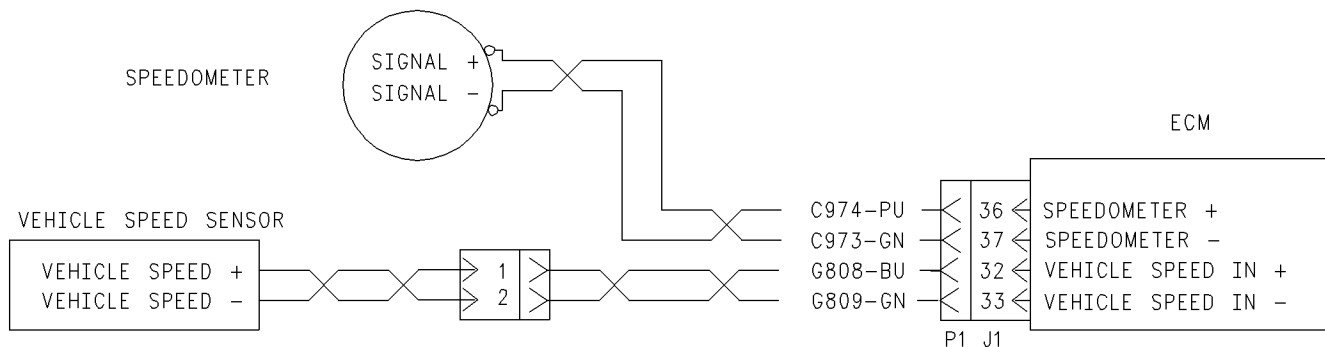

Illustration 181

g00643046

Schematic for a single coil speed sensor and an ECM driven speedometer

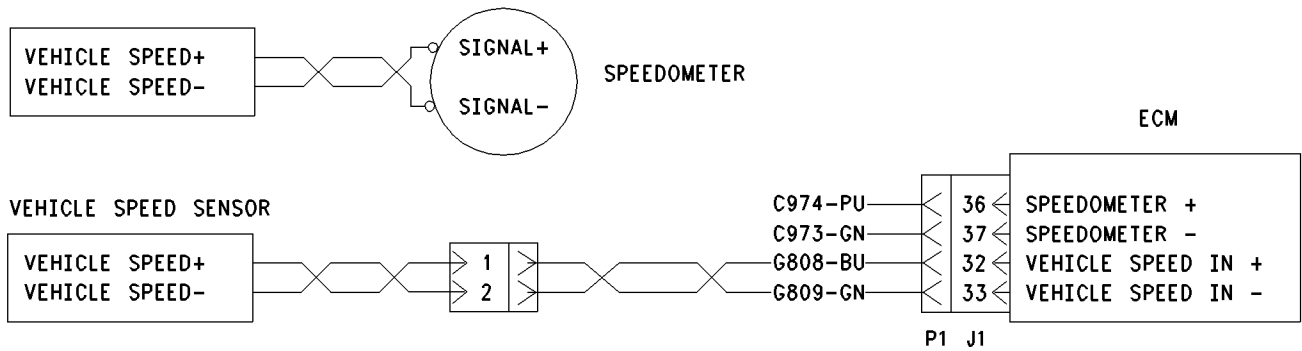

Illustration 182

g00643048

Schematic for a single coil speed sensor and a second single coil sensor for a speedometer

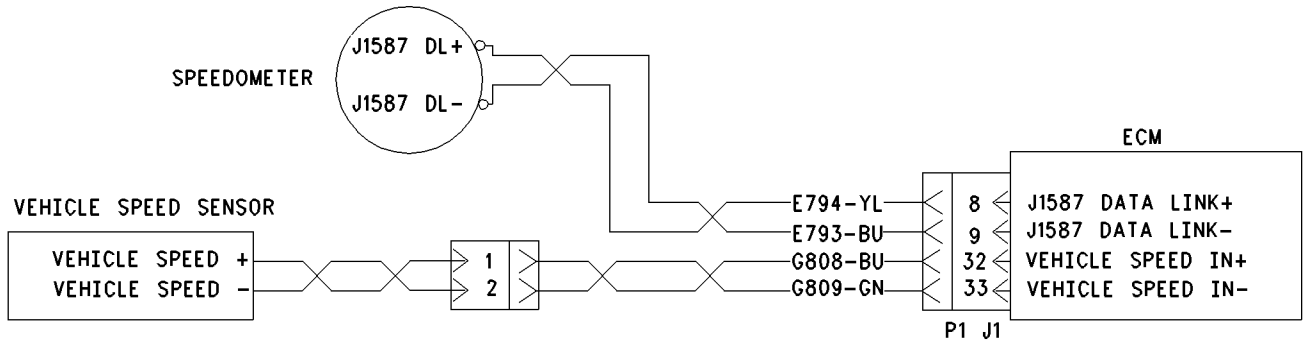

Illustration 183

g00643050

Schematic for a single coil speed sensor and a Data Link driven speedometer

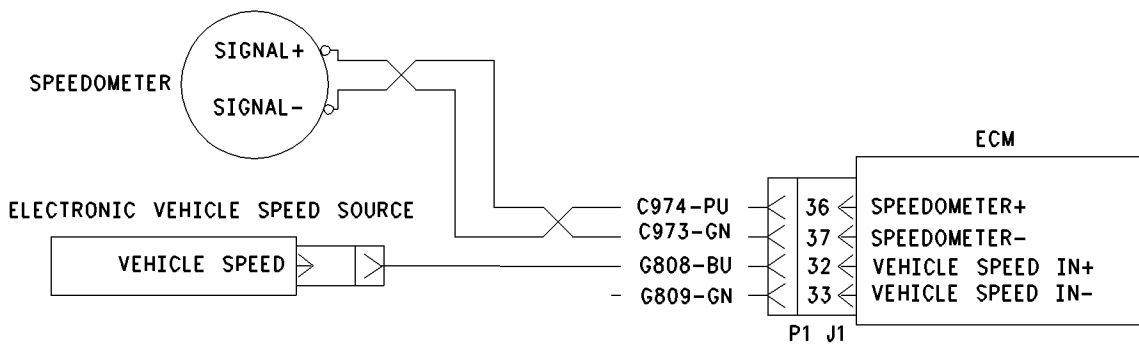

Illustration 184

g00643051

Schematic for an Electronic vehicle speed source and an ECM driven speedometer

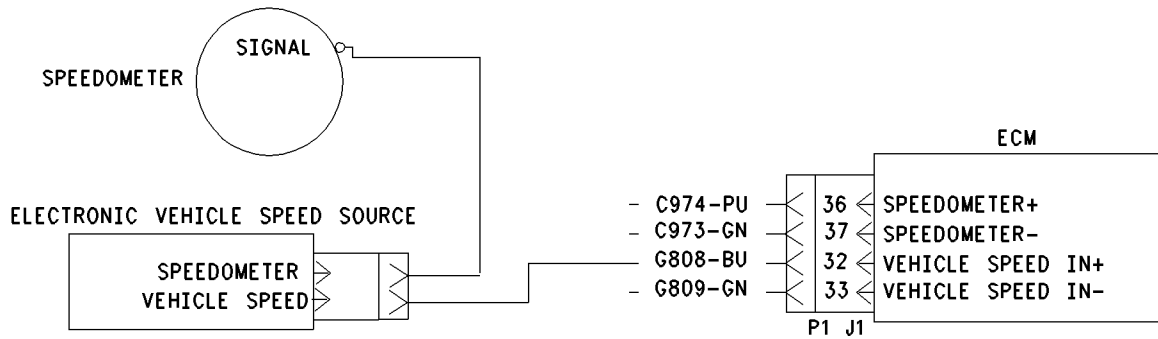

Illustration 185

g00643052

Schematic for an Electronic vehicle speed source and a speedometer

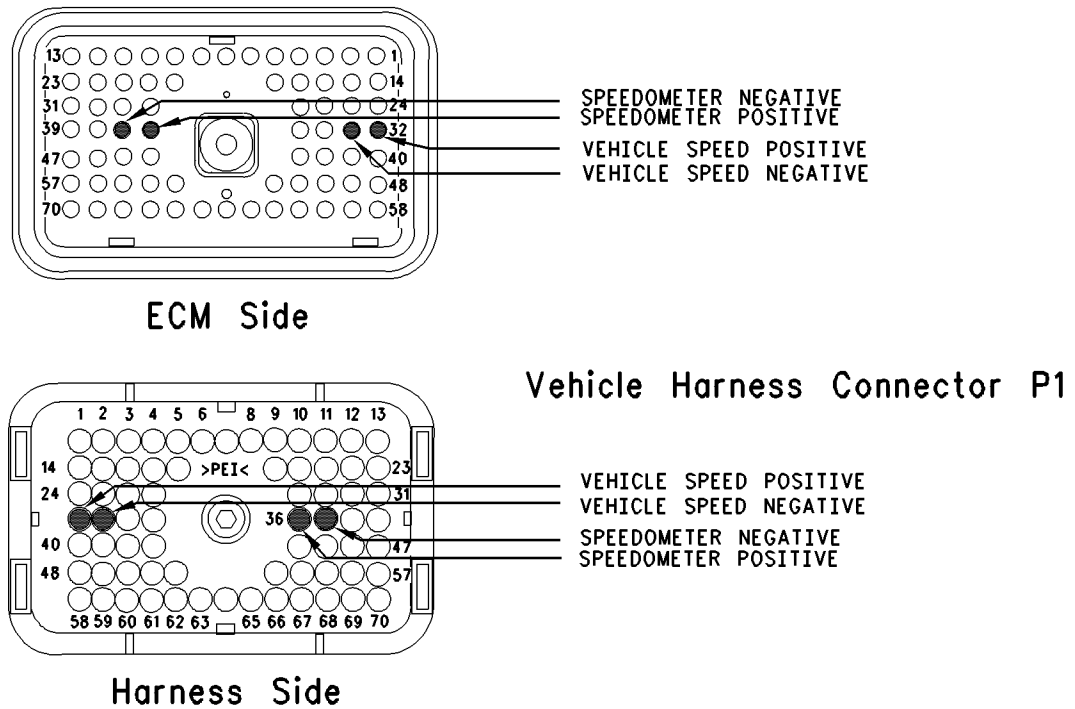

Illustration 186

g00643054

Terminal locations for ECM

Test Step 1. Inspect Electrical Connectors and Wiring.

- A.** Thoroughly inspect ECM vehicle harness connector J1/P1, the firewall bulkhead connector and the terminals for vehicle speed (terminals 32 and 33) in the connectors. Refer to Troubleshooting, "Electrical Connectors - Inspect" for details.
- B.** Perform a 45 N (10 lb) pull test on each of the wires in the ECM connector that are associated with the vehicle speed sensor.

Refer to Illustration 186.

- C.** Check the ECM connector (allen head screw) for the proper torque of 6.0 N·m (55 lb in).
- D.** Check the harness and wiring for abrasion and pinch points from the sensor to the ECM.

Expected Result:

All connectors, pins and sockets should be completely coupled and/or inserted and the harness and wiring should be free of corrosion, abrasion or pinch points.

Results:

- OK – Proceed to Test Step 2.
- Not OK

Repair: Perform the following repair:

Repair the connectors or wiring and/or replace the connectors or wiring. Ensure that all of the seals are properly in place and ensure that the connectors are completely coupled.

Verify that the repair eliminates the problem.

STOP.

Test Step 2. Determine the Type of Vehicle Speed Problem.

- A.** Perform a dynamometer test on the vehicle or perform a road test on the vehicle. Compare the vehicle speed on the ET status screen against the speedometer. Also, compare the vehicle speed on the ET status screen against the actual vehicle speed. The actual vehicle speed can be measured on a dynamometer or the actual vehicle speed can be measured by a stopwatch.
- B.** Monitor the vehicle speed status on ET while the vehicle is parked and the engine is running.
- C.** Operate various electrical devices in the vehicle while the vehicle speed is being monitored. In order to operate the various electrical devices, cycle the electrical devices to the ON position and the OFF position.
- D.** Increase the engine rpm a few times and decrease the engine rpm a few times.

Note: If the operation of a specific electrical device is producing a vehicle speed problem, the electrical device may be the source of an electrical noise problem. An electrical noise problem is also a possibility if increasing the engine rpm on a stationary vehicle produces a vehicle speed problem.

Expected Result:

Result 1 The speed that is displayed on the ET status screen and the speed of the ECM driven speedometer are stable and both speeds agree with the actual speed.

Result 2 The ET status screen and speed is stable, but incorrect.

Result 3 The ET status screen agrees with the actual speed, but the ECM driven speedometer is incorrect or inoperable.

Result 4 The speed that is displayed on the ET status screen is not present, unstable, or erratic.

Results:

- **Result 1** – There is not a vehicle speed problem at this time. If a problem still exists, continue troubleshooting until the condition is resolved.
STOP.
- **Result 2** – Proceed with vehicle speed calibration and adjustment.

Repair: Perform the following diagnostic procedure:

Troubleshooting, “Vehicle Speed Circuit - Calibrate”

STOP.

- **Result 3** – Proceed to Test Step 3.
- **Result 4** – Proceed to Test Step 4.

Test Step 3. Use ET to Check the Speedometer.

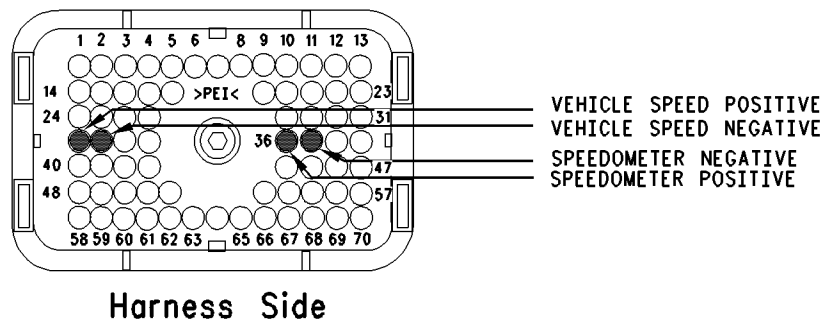

Illustration 187

g00723985

- A.** Inspect vehicle harness connector P1. Observe whether connections are present to terminal 36 (speedometer positive) and/or terminal 37 (speedometer negative).

If there is a connection to either of the speedometer terminals continue with the procedure.

- B.** Connect ET to the cab data link connector.
- C.** Access the “55 mph VSP/Speedometer Test” by Accessing the following display screens in order:
- “Diagnostics”
 - “Diagnostic Tests”
 - “Special Test menu”
- D.** Activate the test and observe the speedometer.

Note: Some types of speedometers only require one ECM signal line to be connected to the speedometer. Either of the ECM terminals can be used for these speedometers.

Refer to Illustration 187.

Expected Result:

The speedometer indicates 80 to 96 km/h (50 to 60 mph).

Results:

- **Yes** – The ECM is providing the signal for the speedometer and the wiring and the speed are OK. Send the vehicle to the OEM dealer for repair of the speedometer. **STOP.**
- **ECM not connected to speedometer**

Repair: Perform the following repair:

If the ECM is not connected to the OEM speedometer, send the vehicle to the OEM dealer for repair of the speedometer.

STOP.

- **No speed indicated** – If OEM truck wiring diagrams are available, trace the wiring to the speedometer and repair the speedometer, as required. **STOP.**

- **Speed present, but not in range**

Repair: Perform the following diagnostic procedure:

Troubleshooting, “Vehicle Speed Circuit - Calibrate”

STOP.

Test Step 4. Determine the Type of Vehicle Speed Circuit.

- A.** Inspect the vehicle wiring for the type of vehicle speed circuit that is being used.

Compare the vehicle speed circuit with the detailed circuit schematics:

Schematic 1 Refer to Illustration 181.

Schematic 2 Refer to Illustration 182.

Schematic 3 Refer to Illustration 183.

Schematic 4 Refer to Illustration 184.

Schematic 5 Refer to Illustration 185.

Select the schematic that is similar to the circuit that is being repaired.

Expected Result:

RESULT 1 The vehicle speed circuit is similar to Schematic 1, 2, or 3.

RESULT 2 The vehicle speed circuit is similar to Schematic 4 or 5.

RESULT 3 The ECM is configured for the “J1939 Trans” option.

Results:

- **Result 1** – Proceed to Test Step 5.
- **Result 2** – The vehicle speed circuit is similar to Schematic 4 or 5. Proceed to Test Step 7.
- **Result 3** – Proceed to Test Step 9.

Test Step 5. Measure Vehicle Speed Sensor Resistance at the Sensor.

- A.** Disconnect the vehicle speed sensor from the vehicle harness.
- B.** Thoroughly inspect the connector. Ensure that the connector terminals are free of corrosion and ensure that the connector terminals are fully seated into the housing of the connector. Repair the connector terminals or replace the connector terminals, as required.
- C.** Measure the resistance between the two terminals of the sensor connector. The sensor resistance measurement should be 100 to 4500 Ohms.
- D.** Reverse the meter leads and measure the resistance. Switching the probes should not change the resistance measurement by more than 10 Ohms.

Expected Result:

The sensor resistance that is measured is between 100 and 4500 Ohms and the sensor resistance that is measured is within 10 Ohms with the meter probes in either position.

Results:

- **OK** – Reconnect the sensor to the vehicle harness. Proceed to Test Step 6.
- **Not OK**

Repair: Perform the following repair:

If the sensor is damaged, replace the damaged sensor or send the vehicle to the OEM dealer for repairs.

Verify that any repair eliminates the problem.

STOP.

Test Step 6. Inspect the Passive Magnetic Speed Sensor for Vehicle Speed.

- A.** Remove the vehicle speed sensor from the transmission and inspect the vehicle speed sensor for steel shavings, debris, or damage.

Note: Shavings and debris on the sensor may occur unless the transmission fluid is drained and replaced according to the maintenance schedule.

- B.** Wipe off the sensor until the sensor is clean. Test the sensor according to the manufacturer's instructions. The sensor is OEM supplied.

Note: If the gap between the vehicle speed sensor and the chopper wheel is too small, the sensor may be damaged. Also if the gap between the vehicle speed sensor and the chopper wheel is too small, the sensor may create a signal due to the vibration of the chopper wheel. This will cause a vehicle speed signal when the vehicle is parked. If the vehicle is parked and a vehicle speed signal is produced, back out the sensor from the wheel until the signal disappears. Use caution. backing out the sensor too far may cause a loss of the vehicle speed signal. Back out the sensor no more than one turn to one and one quarter turns.

Expected Result:

The vehicle speed sensor is correctly installed and undamaged.

Results:

- **OK** – Proceed to Test Step 7.
- **Not OK**

Repair: Perform the following repair:

If the sensor is damaged, replace the damaged sensor or send the vehicle to the OEM dealer for repairs.

Verify that any repair eliminates the problem.

STOP.

Test Step 7. Test ECM Vehicle Speed Inputs by Using the Speedometer Special Test.

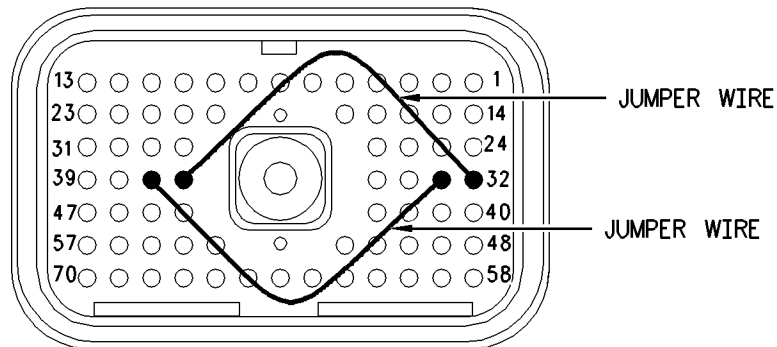

Illustration 188

g00643436

Jumper wire locations for breakout T

- A. Turn the ignition key switch to the OFF position.
- B. Fabricate two jumper wires 100 mm (4 inch) long. Crimp a Deutsch pin to both ends of the wires.
- C. Disconnect vehicle harness connector P1 from the ECM.
- D. Connect a breakout T to ECM connector J1 and connect P1 to the breakout T.
- E. Install one jumper into the breakout T in order to connect terminal 36 (speedometer positive) to terminal 32 (vehicle speed in positive). Install the other jumper into the breakout T in order to connect terminal 37 (speedometer negative) to terminal 33 (vehicle speed in negative).

Refer to Illustration 188.
- F. Turn the ignition key switch to the ON position.
- G. Connect ET to the cab data link connector.
- H. Access the “55 mph VSP/Speedometer Test” by Accessing the following display screens in order:
 - “Diagnostics”
 - “Diagnostic Tests”
 - “Special Test menu”
- I. Activate the test and observe the vehicle speed on the vehicle speed status screen.

Expected Result:

ET indicates a constant vehicle speed between 80 to 96 km/h (50 to 60 mph) when the jumper wires from the speedometer circuit are connected.

Results:

- **OK** – The ECM is operating correctly. The source of the problem is either the wiring or the source of the problem is the vehicle speed sensor.

Repair: Perform the following repair:

If the sensor is damaged, replace the damaged sensor or send the vehicle to the OEM dealer for repairs.

Verify that any repair eliminates the problem.

STOP.

- **Not OK** – Recheck the connections of the jumper wires. Leave the jumper wires installed in the breakout T. Disconnect the breakout T. Proceed to Test Step 8.

Test Step 8. Test the ECM Vehicle Speed Inputs When the Test ECM is Installed.

- A. Connect a test ECM and reconnect the breakout T.
- B. Install one jumper into the breakout T in order to connect terminal 36 (speedometer positive) to terminal 32 (vehicle speed in positive). Install the other jumper into the breakout T in order to connect terminal 37 (speedometer negative) to terminal 33 (vehicle speed in negative).

Refer to Illustration 188.

- C. Turn the ignition key switch to the ON position.
- D. Connect ET to the cab data link connector.
- E. Access the “55 mph VSP/Speedometer Test” by Accessing the following display screens in order:
 - “Diagnostics”
 - “Diagnostic Tests”
 - “Special Test menu”
- F. Activate the test and observe the vehicle speed on the vehicle speed status screen.

Expected Result:

ET indicates a constant vehicle speed between 80 to 96 km/h (50 to 60 mph) when the jumper wires from the speedometer circuit are connected.

Results:

- OK

Repair: Perform the following repair:

Reconnect the suspect ECM. If the problem returns with the suspect ECM, replace the ECM.

STOP.

- Not OK – Recheck the connectors. Continue troubleshooting until original condition is resolved. STOP.

Test Step 9. Verify Correct Programming for the “J1939 Vehicle Speed Calibration” Parameter

- A. Connect ET to the cab data link connector.
- B. Access the list of “Configuration Parameters” on the service tool and verify that the “Vehicle Speed Input” parameter is programmed to the “J1939 Trans” option.
- C. Verify that the “Powertrain Datalink” parameter is programmed to “J1939”.
- D. Verify that the correct value is used for the “Vehicle Speed Cal (J1939-Trans)” parameter. Refer to Troubleshooting, “Vehicle Speed Circuit - Calibrate” for details.
- E. Verify that the J1939 data link is connected to the ECM and that the data link is functioning properly. Refer to Troubleshooting, “Powertrain Datalink Circuit - Test”.

- F. Compare the Vehicle speed reading on the ET status screen to the vehicle speedometer and the actual vehicle speed.

Expected Result:

The “Vehicle Speed” on the ET status screen is within 8 km/h (5 mph) of the speedometer and the actual vehicle speed readings.

Results:

- Yes – The ECM is receiving J1939 data from the transmission ECM. Send the vehicle to the OEM dealer for repair of the wiring for the speedometer or for the repair of the transmission vehicle speed sensor. STOP.

- No – Perform the following repair:

Repair: Connect a test ECM. Program all of the parameters that are related to vehicle speed to the same setting as the original ECM. Repeat the previous test step. If the test ECM functions properly and the original ECM does not function properly, replace the ECM. If the test ECM does not correct the problem, send the vehicle to the OEM dealer for repair of one of the following components:

- speedometer
- wiring
- Transmission ECU
- transmission speed sensor
- wiring for the J1939 data link

STOP.

i01611459

Wait To Start Lamp Circuit - Test

SMCS Code: 7431-081

System Operation Description:

Use this procedure under the following situation:

Use the following information in order to determine if the Wait to Start Lamp is operating incorrectly.

Terminal 31 (Output 9)

The output 9 (terminal 31) can be used as a fast idle lamp or a Wait to Start Lamp output. The “Output #9” parameter defaults to “Fast Idle Lamp”, but the parameter can be programmed to operate as a wait to start lamp.

Note: When the “Truck Manufacturer” is programmed to “GM” configurations the “Output #9” parameter is unavailable. The “Output #9” parameter functions as fast idle lamp output.

If the “Output #9” parameter is programmed to “Wait To Start Lamp”, the ECM will turn on output 9 when the air inlet heater is operating and the engine is not running. The wait to start lamp functions similarly to the lamp for the air inlet heater that can be installed in parallel with the relay for the air inlet heater circuit. The wait to start lamp illuminates only when the engine is not running. The lamp for the air inlet heater illuminates when the relay for the air inlet heater is energized.

OCT01 Software

The parameter “Output #9” is no longer available. The parameter “Wait To Start Lamp” can be programmed to “J1/P1:31” or “None”. When the parameter is programmed to “J1/P1:31” a lamp circuit can be connected to terminal 31 in order to indicate that the air inlet heater is on and the engine is not running. The parameter “Fast Idle Enabled Lamp” must be programmed to “J1/P1:21” for this feature to be used.

Note: This feature is only available when “Truck Manufacturer” is programmed to “Other”.

Electrical Connection of Lamps

One terminal of the lamp must be connected to battery voltage through the vehicle wiring. The other terminal is connected to the ECM at the vehicle harness connector J1/P1 at terminal 31.

The ECM provides a path to ground in order to turn on the lamp.

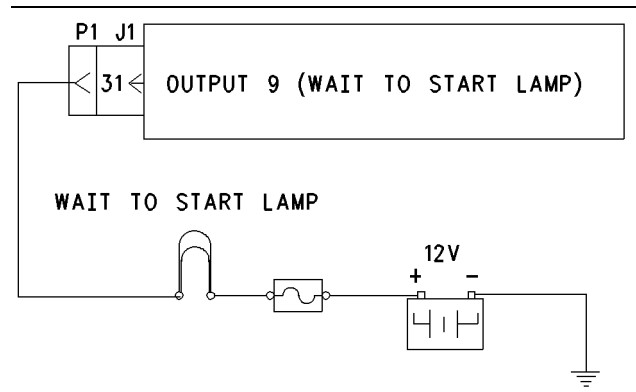

Illustration 189

g00770585

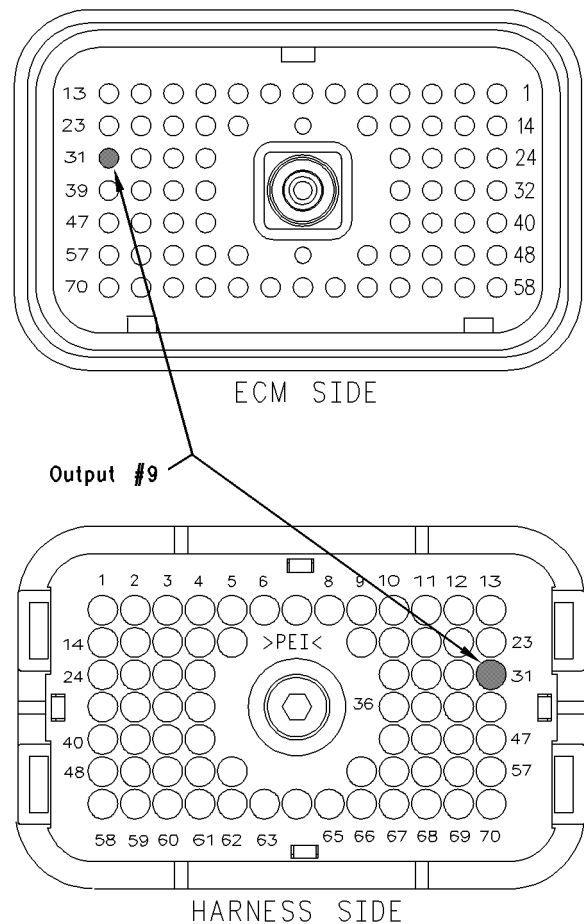

Illustration 190

g00770189

Test Step 1. Inspect Electrical Connectors and Wiring.

- A. Thoroughly inspect ECM vehicle harness connector J1/P1, the firewall bulkhead connector, or the wait to start lamp. Refer to Troubleshooting, “Electrical Connectors - Inspect” for details.

- B.** Perform a 45 N (10 lb) pull test on each of the wires in the ECM connector that are associated with the wait to start lamp.

Refer to Illustration 190.

- C.** Check the ECM connector (allen head screw) for the proper torque of 6.0 N·m (55 lb in).
- D.** Check the harness and wiring for abrasion and pinch points from the battery to the ECM.

Expected Result:

All connectors, pins and sockets should be completely coupled and/or inserted and the harness and wiring should be free of corrosion, abrasion or pinch points.

Results:

- **OK** – Proceed to Test Step 2.
- **Not OK**

Repair: Repair the connectors or wiring and/or replace the connectors or wiring. Ensure that all of the seals are properly in place and ensure that the connectors are completely coupled.

STOP.

Test Step 2. Check for Normal Operation of the Wait to Start Lamp.

- A.** Connect ET. Access the configuration screen and ensure that the “Output #9” parameter is programmed to “Wait To Start Lamp”. For OCT01 Software, ensure that “Wait to Start Lamp” is programmed to “J1/P1:31”. Also, “Fast Idle Enabled Lamp” must be programmed to “J1/P1:21”.
- B.** Turn the ignition key switch to the OFF position for ten seconds. Turn the ignition key switch to the ON position.
- C.** The wait to start lamp should illuminate for approximately two seconds when the key switch is turned on. If conditions require the air inlet heater to turn on, the wait to start lamp should remain illuminated until the air inlet heater turns off or the engine is started.

Expected Result:

The wait to start lamp turns on and the wait to start lamp turns off per the above description.

Results:

- **Yes** – The wait to start lamp appears to operating correctly at this time. **STOP.**

- **No** – Proceed to Test Step 3.

Test Step 3. Test the Circuit for the Wait to Start Lamp

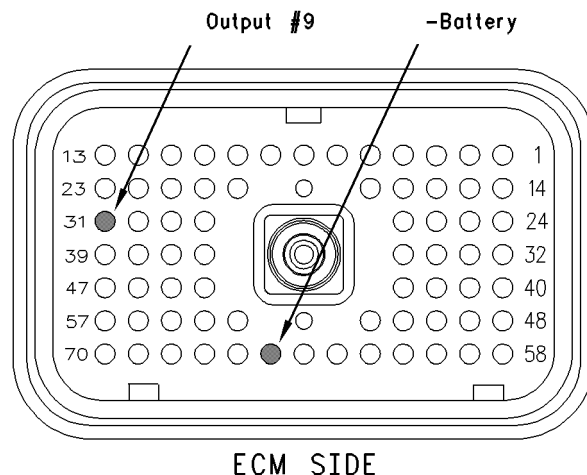

Illustration 191

g00770210

Vehicle harness connector P1

- A.** Disconnect ECM vehicle harness connector J1/P1.
- B.** Fabricate a jumper wire 100 mm (4 inch) long. Crimp a Deutsch pin to both ends of the wire.
- C.** Insert the jumper into terminal 31 of connector P1.
- D.** Connect the other end of the jumper wire to terminal 65 (–battery) of connector P1.
- E.** Turn the ignition key switch to the ON position.
- F.** While the lamp is being watched, insert the jumper wire and remove the jumper wire.

Refer to Illustration 191.

Expected Result:

Result 1 The wait to start lamp turns on while the jumper is connected to both sockets. Also, the wait to start lamp turns off when the jumper is removed from one of the sockets.

Result 2 The lamp does not turn on while the jumper is connected to both sockets.

Result 3 The lamp will stay on while the ECM vehicle harness connector is disconnected.

Results:

- **Result 1** – The wait to start lamp is functioning properly. Proceed to Test Step 4.
- **Result 2** – The lamp did not turn on. The vehicle's lamp circuit is not functioning properly. The lamp is probably burned out or there is a problem in the wiring from the cab to either the ECM or the +Battery connection. Repair the lamp circuit or send the vehicle to the OEM dealer for repairs. **STOP.**
- **Result 3**

Repair: Perform the following diagnostic procedure:

The circuit between the ECM and the lamp is shorted to chassis ground. Repair the circuit or send the vehicle to the OEM dealer for repairs.

STOP.

Test Step 4. Check ECM Operation of Wait to Start Lamp.

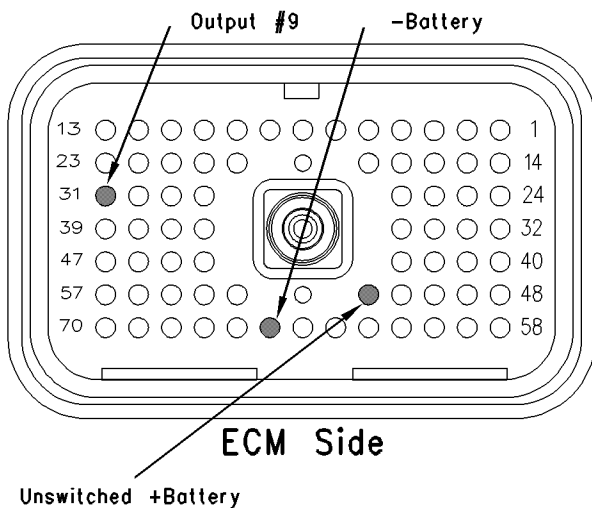

Illustration 192
ECM breakout T-connector

g00770221

- A.** Disconnect ECM vehicle harness connector J1/P1.
- B.** Insert a breakout T between ECM vehicle harness connector J1 and ECM vehicle harness connector P1.

- C.** Connect one probe of the voltage test lamp to terminal 65 (-battery). Connect the other probe of the voltage test lamp to terminal 52 (unswitched +battery) of the breakout T.
- D.** The test lamp should turn on. If the test lamp does not turn on, either the test lamp is faulty or the wiring to the ECM is faulty. Continue with this step if the lamp turns on.
- E.** Leave the probe of the test lamp connected to terminal 52 (unswitched +battery).
- F.** Connect the other probe of the test lamp to terminal 31 (output 9) of the breakout T.

Refer to Illustration 192.
- G.** Turn the ignition key switch to the OFF position.
- H.** Connect ET to the cab data link connector. Access the configuration screen and ensure that the "Output #9" parameter is programmed to "Wait To Start Lamp".
- I.** Turn the ignition key switch to the OFF position for ten seconds. Turn the ignition key switch to the ON position.

- J.** The wait to start lamp should illuminate for approximately two seconds when the key switch is turned on. If conditions require the air inlet heater to turn on, the wait to start lamp should remain illuminated until the air inlet heater turns off or the engine is started.

Expected Result:

The test lamp turns on and the test lamp turns off per the above description.

Results:

- **Yes** – The ECM is operating correctly. There is a problem in the vehicle wiring or the lamp. **STOP.**
- **No**

Repair: Temporarily connect a test ECM. Ensure that the "Output #9" parameter is programmed to "Wait To Start Lamp". Check the ECM operation of the PTO Switch ON Lamp when the test ECM is installed. If the problem is resolved with the test ECM, reconnect the suspect ECM. If the problem returns with the suspect ECM, replace the ECM.

STOP.

i01611513

Warning Lamp Circuit - Test

SMCS Code: 7431-081

System Operation Description:

Use this procedure under the following situation:

Use the following information in order to determine if the warning lamp is operating incorrectly:

The following background information is related to the following procedure:

Warning Lamp Operation

A warning lamp is required if the "Engine Monitoring" feature is used. The warning lamp indicates an active problem with one of the monitored conditions such as high coolant temperature. A flashing warning lamp indicates that the engine is derating power. The warning lamp will turn on for a minimum of two seconds after the engine has started.

With SEP00 software and newer software, an option is available for the "GM Truck Manufacturer" configuration that allows the output for warning lamp to be configured as an output for a warning lamp for high coolant temperature. The "Engine Monitoring Lamps" parameter must be programmed to the "Warning Lamp" option for standard operation of engine monitoring. If the "Engine Monitoring Lamps" parameter is programmed to the "High Coolant Temp Warning Lamp" option, the output is used as an interface to the GM shutdown system. Refer to Troubleshooting, "High Coolant Temp Warning Lamp Output Circuit - Test" for details.

Operation Of Engine Monitoring

When the ECM has detected an engine condition that exceeds the acceptable limits, the warning lamp will turn on. The activation of the lamp depends on the existing conditions and the programming of the parameter for "Engine Monitoring". The lamp will activate in one of the following modes:

- The lamp not only turns on, but the lamp stays on.
- The lamp will flash on and off.

If the lamp turns on continuously, the engine is in warning mode. If the lamp begins to flash, the ECM has begun to derate engine speed, vehicle speed, or power.

If the parameter for Engine Monitoring is programmed to "WARNING", the lamp will not flash. The lamp only flashes when the engine is programmed to "DERATE" or "SHUTDOWN".

If the Customer Parameter for Engine Monitoring is programmed to "WARNING", "DERATE", or "SHUTDOWN" the lamp will turn on when a warning condition exists. The lamp will be turned on continuously while a warning condition exists.

If the Customer Parameter for Engine Monitoring is programmed to "DERATE" or "SHUTDOWN", the lamp flashes whenever Engine Monitoring is derating engine speed, vehicle speed, and power.

If the Customer Parameter for Engine Monitoring is programmed to "SHUTDOWN", the warning lamp will continue flashing after the derate mode until the engine is shut down. Refer to Troubleshooting, "System Overview".

Electrical Connection of Lamps

One terminal of the lamp must be connected to battery voltage through the vehicle wiring. The other terminal is connected to the ECM at the ECM vehicle harness connector J1/P1 at terminal 29 (warning lamp).

The ECM provides a path to ground in order to turn the lamp ON.

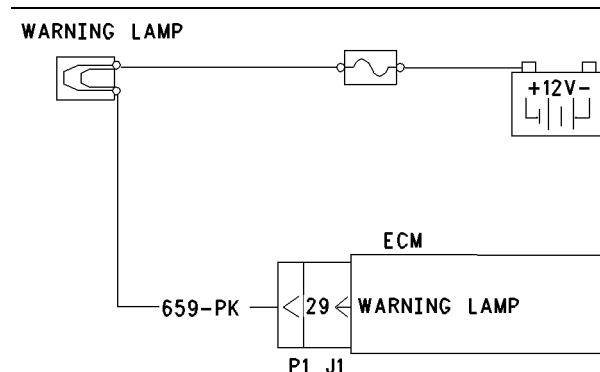

Illustration 193

g00769338

Schematic for the circuit of the warning lamp

ENGINE HARNESS CONNECTOR P1

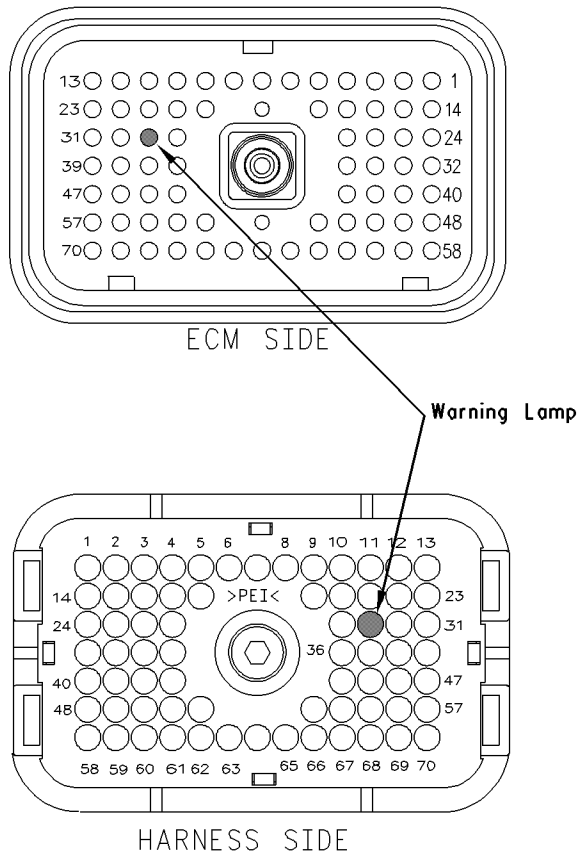

Illustration 194

g00769348

Pin locations for the Warning Lamp circuit

Test Step 1. Inspect Electrical Connectors and Wiring.

- Thoroughly inspect ECM vehicle harness connector J1/P1, the firewall bulkhead connector, and terminal 29. Refer to Illustration 194. Refer to Troubleshooting, "Electrical Connectors - Inspect" for details.
- Perform a 45 N (10 lb) pull test on each of the wires in the ECM connector that is associated with the suspect terminal for the lamp.
- Check the ECM connector (allen head screw) for the proper torque of 6.0 N·m (55 lb in).
- Check the harness and wiring for abrasion and pinch points from the battery to the ECM.

Expected Result:

All connectors, pins and sockets should be completely coupled and/or inserted and the harness and wiring should be free of corrosion, abrasion or pinch points.

Results:

- OK – Proceed to Test Step 2.
- Not OK

Repair: Repair the connectors or wiring and/or replace the connectors or wiring. Ensure that all of the seals are properly in place and ensure that the connectors are completely coupled.

STOP.

Test Step 2. Check for Normal Operation of the Warning Lamp.

- Monitor the warning lamp. Turn the ignition key switch to the ON position, while the engine is OFF. The lamp should turn on for five seconds. Then, the lamp should turn off.

The lamp will continue flashing if there is an active diagnostic code. If there is an active diagnostic code, connect ET in order to read the active diagnostic code. Troubleshoot the problem.

Note: The warning lamp will not turn on until the engine is cranked.

- Connect ET to the cab data link connector. Verify that the "Engine Monitoring" has been programmed to "WARNING", "DERATE", or "SHUTDOWN". If "Engine Monitoring" is programmed to "OFF", the warning lamp is not used and the ECM will not turn on the lamp.

While the warning lamp is being observed, start the engine. The warning lamp should turn on for a minimum of two seconds after the engine starts. Then, the warning lamp should turn off. If the lamp remains off, immediately shut down the engine.

Expected Result:

The warning lamp turns on and the warning lamp turns off per the above description.

Results:

- OK – The lamp appears to operating correctly at this time. STOP.

- **Not OK** – The lamp does not turn on. Proceed to Test Step 3.
- **Not OK** – The lamp stays on.

Repair: Perform the following diagnostic procedure:

Use ET to determine if an “Engine Monitoring” condition is causing the lamp to turn on. If an “Engine Monitoring” condition is not present, perform the following diagnostic procedure.

Proceed to Test Step 3.

Test Step 3. Test the Lamp Circuit.

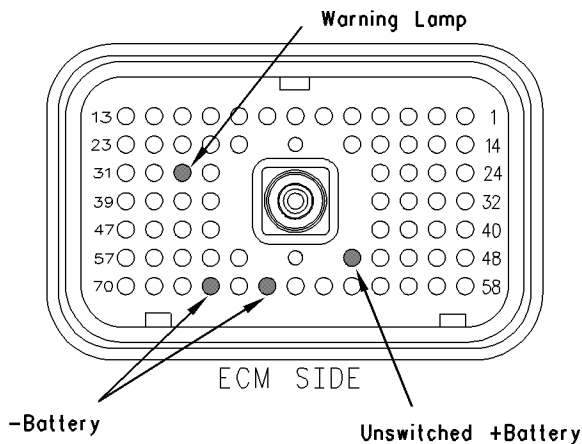

Illustration 195

g00769361

Vehicle harness connector P1

- Disconnect ECM vehicle harness connector J1/P1.
- Fabricate a jumper wire 100 mm (4 inch) long. Crimp a Deutsch pin to both ends of the wire.
- Insert the jumper into terminal 29 (warning lamp) of connector P1. The jumper can be inserted into the following terminals in order to test the appropriate lamp circuit:
- Connect the other side of the jumper wire to P1 terminal 65 (-battery).
- Turn the ignition key switch to the ON position.
- While the lamp is being watched, insert the jumper wire and remove the jumper wire.

Refer to Illustration 195.

Expected Result:

Result 1 The warning lamp turns on while the jumper is connected to both sockets. Also, the warning lamp turns off when the jumper is removed from one of the sockets.

Result 2 The lamp does not turn on while the jumper is connected to both sockets.

Result 3 The lamp will stay on while the ECM vehicle harness connector is disconnected.

Results:

- **Result 1** – The warning lamp circuit is functioning properly. Proceed to Test Step 4.
- **Result 2** – The lamp did not turn on. The vehicle’s lamp circuit is not functioning properly. The lamp is probably burned out or there is a problem in the wiring from the cab to either the ECM or the +battery connection. Repair the lamp circuit or send the vehicle to the OEM dealer for repairs. **STOP.**

- **Result 3**

Repair: Perform the following diagnostic procedure:

The circuit between the ECM and the lamp is shorted to chassis ground. Repair the circuit or send the vehicle to the OEM dealer for repairs.

STOP.

Test Step 4. Check ECM Operation of the Warning Lamp.

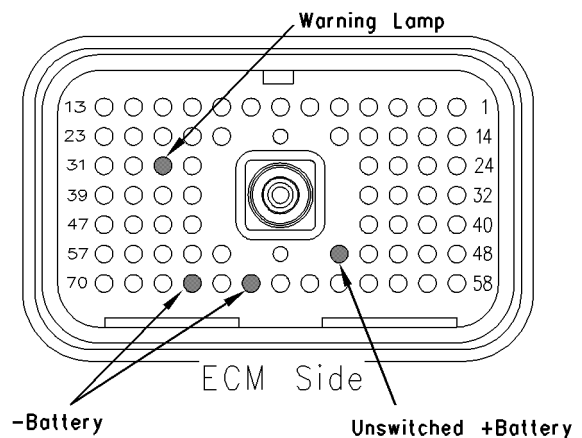

Illustration 196

g00769368

ECM breakout T-connector

- A. Disconnect ECM vehicle harness connector J1/P1.
- B. Insert a breakout T between the ECM vehicle harness connectors J1 and P1.
- C. Connect a test light probe to terminal 65 (-battery) and connect the other probe to terminal 52 (unswitched +battery) of the breakout T.
- D. The test lamp should turn on. If the test lamp does not turn on, either the test lamp is faulty or the wiring to the ECM is faulty. Continue with this step if the lamp turns on.
- E. Leave the test light probe connected to terminal 52 (unswitched +battery).
- F. Connect the other test light probe to terminal 29 on the breakout T.

Refer to Illustration 196.

- G. Watch the voltage test lamp. Start the engine. The lamp should turn on for a minimum of two seconds after the engine starts. Then, the lamp should turn off. Immediately turn the engine off if the lamp continues to stay on. Use ET to determine the cause of the problem.

Expected Result:

The warning lamp turns on and the warning lamp turns off per the above description.

Results:

- **Yes** – The ECM is operating correctly. There is a problem in the vehicle wiring or the lamp. Repair the vehicle wiring or the lamp, as required. **STOP.**
- **No** – Temporarily connect a test ECM. Ensure that the “Engine Monitoring” parameter of the test ECM matches the “Engine Monitoring” parameter of the suspect ECM. Check the ECM operation of the lamp when the test ECM is installed. If the problem is resolved with the test ECM, reconnect the suspect ECM. If the problem returns with the suspect ECM, replace the ECM. **STOP.**

Calibration Procedures

i01725180

Engine Speed/Timing Sensor - Calibrate

SMCS Code: 1912-524

System Operation Description:

Use this procedure under the following situation:

Use this procedure if any of the following conditions exist:

- 22-13 Check Timing Sensor Calibration (42)

A timing calibration must be performed under the following conditions:

- The ECM requires replacement and the ECM will not communicate with Caterpillar Electronic Technician (Cat ET) in order to allow the timing calibration to be copied when the "Copy Configuration-ECM Replacement" feature is used.
- Work has been performed on the engine drive train (front).

Note: The timing calibration will not increase the available engine power or the timing calibration will not decrease the available engine power. Do not expect an increase in power due to the performance of the timing calibration.

Replacement ECM

If a replacement ECM is required, the ECM parameters and the timing calibration can be transferred from the suspect ECM to the replacement ECM. Timing calibration will NOT be necessary. This feature requires Cat ET and this feature is only possible if the existing ECM can communicate with Cat ET.

Table 203

Required Special Tools	
Part Number	Description
6V-2197	Magnetic Transducer
7X-1695	Cable
7X-1111	Grommet
9S-9082	Engine Turning Tool
170-3519	Harness

Test Step 1. Install the 7X-1171 Transducer Adapter

- Turn the ignition key switch to the OFF position.
- Remove the timing calibration plug from the left or right front face of the flywheel housing.
- Install the 7X-1171 Transducer Adapter into the hole for the plug.

Results:

- OK – Proceed to Test Step 2.

Test Step 2. Install the 6V-2197 Magnetic Transducer on the Engine.

- Put a 2D-6392 O-Ring Seal on the end of the magnetic transducer.

Note: A small amount of clean engine oil will allow the seal to slide onto the transducer more easily.

- Push the magnetic transducer through the adapter until the magnetic transducer comes in contact with the outermost portion of the flywheel timing calibration ring. Move the O-ring seal downward against the adapter.
- Withdraw the magnetic transducer 1.0 mm (0.04 inch) and hand tighten the nut on the adapter sleeve in order to secure the magnetic transducer in place.
- Check that the probe is properly installed and snug. The probe should not move when the engine is started.
- Connect the 6V-2197 Magnetic Transducer to the 7X-1695 Cable.
- Remove the access cover from the J400 engine timing calibration connector.

Note: Some engines do not have a J400 engine timing calibration connector in the engine harness. A 170-3519 Harness is required. Refer to Special Instruction, REHS0399, "Installation Of The 170-3519 Timing Calibration Harness Assembly On The 3126B Truck Engine" for the installation procedure.

Results:

- OK – Proceed to Test Step 3.

Test Step 3. Start the Engine and Allow the Coolant to Reach Operating Temperature

- A.** Start the engine and run at low idle until the engine has warmed up enough to exit Cold Mode operation. The Cat ET status screen will display "COLD MODE" in the upper corner when Cold Mode operation exists. The engine will adjust idle rpm from Cold Mode idle to the programmed Low Idle rpm when Cold Mode operation is complete.
- B.** Check for active diagnostic codes. Use the procedures in this manual to troubleshoot and repair any active diagnostic codes before attempting a calibration check. The engine must not have any diagnostic fault conditions that are present during the timing calibration except the following condition:
- 22-13 Check Timing Sensor Calibration (42)
- C.** After the engine has warmed up, set the engine speed to 1100 rpm by using the cruise control switches or by using the accelerator pedal.

Note: The engine rpm must be steady within the 1000 to 1200 rpm range in order to perform a timing calibration.

Results:

- OK – Proceed to Test Step 4.

Test Step 4. Connect Cat ET

- A.** Connect Cat ET to the cab data link connector.
- B.** After the engine has exited Cold Mode operation, access the "Timing Calibration Screen" on Cat ET. Access the following display screens in order:
- "Service"
 - "Calibrations"
 - "Timing Calibration"

Note: To perform a timing calibration, the engine rpm must remain as steady as possible at approximately 1100 rpm. This can be performed by using the idle engine governor or a steady foot on the accelerator pedal. Any changes to engine rpm that are more than 100 rpm will slow down the procedure. These changes will also reduce the accuracy of the procedure.

- C.** Connect the 7X-1695 Cable for the 6V-2197 Magnetic Transducer to the J400 Speed/Timing Calibration Connector.

- D.** Ensure that all of the connections are made correctly.

Results:

- OK – Proceed to Test Step 5.

Test Step 5. Calibrate the Speed/Timing Sensor

- A.** To calibrate the timing to the correct setting, select "space" on Cat ET. Wait until Cat ET indicates that the timing is "CALIBRATED".

Note: If the Cat ET display reads "CALIBRATION UNSUCCESSFUL", the electronic injection timing has not been set. Recheck the tool installation and tool operation and try again to calibrate electronic injection timing. If the crankshaft and camshaft gears have been reassembled incorrectly, the engine will not calibrate.

If the timing calibration has been successfully completed, do not exit the timing calibration screen on Cat ET until you have disconnected the 7X-1695 Cable for the 6V-2197 Magnetic Transducer from the P400 Speed/Timing Calibration Connector.

Expected Result:

The timing calibration procedure was completed successfully.

Results:

- OK – The timing calibration procedure was completed successfully. Proceed to Test Step 6.

- Not OK

Repair: Perform the following procedure:

1. Verify that the engine rpm was stable during the testing (± 50 rpm). If the engine rpm was unstable or the engine rpm could not be controlled within ± 50 rpm because of mechanical factors or electrical factors, refer to Troubleshooting, "Engine Misfires, Runs Rough or Is Unstable".
2. If all of the problems have been corrected but the timing can not be calibrated, check the cable of the 6V-2197 Magnetic Transducer and check the 6V-2197 Magnetic Transducer in order to verify that the Magnetic Transducer is not bent. If the 6V-2197 Magnetic Transducer is not bent, restart this procedure.

STOP.

Test Step 6. Disconnect the 6V-2197 Magnetic Transducer Before Exiting the “Monitor/Calibrate Timing” Screen on Cat ET

- A. Disconnect the timing probe from the J400 engine timing calibration connector.
- B. Install the cover for the J400 connector.
- C. Exit the timing calibration screen on Cat ET.

Note: Exiting the timing calibration screen on Cat ET will drop the engine rpm to the programmed low idle if the cruise control switches were used to maintain engine rpm during calibration. This is normal.

Expected Result:

The magnetic transducer was disconnected before exiting the timing calibration screen on Cat ET.

Results:

- OK – STOP.
- Not OK – If the magnetic transducer is still installed after exiting the timing calibration screen on Cat ET, vehicle speed diagnostic codes may be generated.

Repair: If vehicle speed diagnostic codes are generated, the vehicle speed diagnostic codes should be cleared.

STOP.

i01642395

Vehicle Speed Circuit - Calibrate

SMCS Code: 7493-524

System Operation Description:

The ECM uses vehicle speed information for the following features:

- Cruise control
- Fast idle control
- Idle speed control
- PTO operation
- Vehicle speed limiting
- Speedometer
- Progressive shift

- Idle shutdown
- Operation of the air inlet heater
- Secure idle theft deterrent
- Trip data
- Maintenance data

With SEP00 and newer software, there are two different methods that can be used to obtain the information for the ECM to use for calculating vehicle speed. The ECM can calculate vehicle speed by either of the following means:

- The ECM monitors the signal from a vehicle speed sensor in pulses per kilometer (mile). The vehicle speed sensor is connected to the ECM vehicle speed input circuit (terminals 32 and 33). This is the “Vehicle Speed Calibration” option.
- The ECM receives a J1939 Datalink Broadcast Message from the Transmission ECU that indicates revolutions per kilometer (mile) of the transmission output shaft. This option is only available with SEP00 and newer software. This is the “Vehicle Speed Cal (J1939-Trans)” option.

Each of these methods require a specific calibration number to be programmed into the ECM to calculate vehicle speed. For the “Vehicle Speed Calibration” option that uses the vehicle speed sensor, the ECM must know the number of pulses that are produced by the vehicle speed sensor during each kilometer (mile) of travel by the vehicle. In order to find the number of pulses that are produced by the sensor, multiply the tire size by the axle ratio. Multiply the number that was obtained in the previous calculation by the number of teeth on the output shaft that is used by the sensor to obtain the pulses. For the “Vehicle Speed Cal (J1939-Trans)” option, the ECM must know the number of times that the output shaft revolves per kilometer (mile) of travel by the vehicle. This can be calculated by one of the following methods:

- Divide the pulses per kilometer (mile) of the sensor on the transmission output shaft by the number of teeth on the transmission output shaft.
- Multiply the axle ratio by the number of revolutions per kilometer (mile) of the tire.

The ECM calculates vehicle speed by converting the vehicle speed signal to kilometers per hour (km/h) or miles per hour (mph). The conversion factor is customer programmable and the conversion factor is stored in pulses per km (PPKM) or pulses per mile (PPM).

The tire revolution variable could be affected by changing from bias ply tires to radial tires, and vice versa. Also, changing to low profile radial tires could affect the tire revolution variable. This result may change the actual vehicle speed which could result in performance complaints or fuel consumption complaints. If the tire configuration has been changed, determine the new tire revolution variable. Enter the new value in pulses per km (PPKM) or pulses per mile (PPM). The preferred method is obtaining the data from the individual tire manufacturers for the specific tire that is being used.

Note: The ECM speedometer signal is set to 18,600 pulses per km (PPKM) or 30,000 pulses per mile (PPM). For “GM Truck Manufacturer” configurations with SEP00 or newer software, the output of the speedometer is set to 2,485 PPKM (4,000 ppm). This setting cannot be changed. All speedometers that are driven by the ECM output (J1/P1 terminal 36 and terminal 37) must match the fixed output of the ECM for proper operation.

Test Step 1. Determine if the ECM Receives the Vehicle Speed Input from the “Vehicle Speed Calibration” Option or from the “Vehicle Speed Cal (J1939-Trans)” Option.

- A.** Connect Caterpillar Electronic Technician (ET) to the cab data link connector. If the software for the ECM is older than SEP00, proceed to Test Step 3.
- B.** If SEP00 or newer software is used in the ECM, access the “Configuration Parameter List”. View the “Vehicle Speed Input” parameter. Determine if the vehicle is configured to use the “Vehicle Speed Calibration” option, “J1/P1:32&33” or the “Vehicle Speed Cal (J1939-Trans)” option.

Expected Result:

The ECM is using software that is dated prior to SEP00 or the ECM is configured to use the “Vehicle Speed Calibration” option.

Results:

- **Yes** – Proceed to Test Step 3.
- **No** – The ECM is configured to use the “Vehicle Speed Cal (J1939-Trans)” option. Proceed to Test Step 2.

Test Step 2. Calculate the Revolutions Per Kilometer (Mile) of the Transmission Output Shaft

- A.** The correct revolutions per kilometer (mile) of the transmission output shaft must be entered for the “Vehicle Speed Cal J1939-Trans” setting. If this value is unknown, either of the following calculations can be used to obtain the correct setting:
 - Divide the pulses per kilometer (mile) of the sensor on the transmission output shaft by the number of teeth on the transmission output shaft.
 - Multiply the axle ratio by the number of revolutions per kilometer (mile) of the tire.
- B.** Program the calculated value into the ECM.

Expected Result:

The value is within the valid range of the ECM.

Results:

- **Yes** – Once the value is entered, verify that the ECM is accurately measuring vehicle speed. Proceed to Test Step 4.
- **No** – Recalculate the value and re-enter the correct value into the ECM. **STOP.**

Test Step 3. Calculating Pulses Per Kilometer (Mile) When all the Variables are Known.

- A.** Calculate pulses per kilometer (PPKM) or pulses per mile (PPM).

$$\text{PPKM} = K \times \text{Ra} \times N.$$

$$\text{PPM} = M \times \text{Ra} \times N.$$

K – This symbol represents the tire revolutions per kilometer. This is a constant that is divided by the tire static loaded radius.

M – This symbol represents the tire revolutions per mile. This is a constant that is divided by the tire static loaded radius.

Ra – This symbol represents the rear axle ratio. The rear axle ratio can typically be found on the housing of the rear axle, or the rear axle ratio can typically be found on the specification sheet for the vehicle.

N – This symbol represents the number of chopper teeth on the transmission drive shaft. The magnetic pickup sensor is mounted here. The number of chopper teeth is usually 16. Some transmissions have 11 tooth chopper wheels.

- B.** Use ET to enter pulses per km (PPKM) or pulses per mile (PPM) into the ECM.

Expected Result:

This value is within the valid range of the ECM.

Results:

- **OK** – Once the value is entered, verify that the ECM is accurately measuring vehicle speed. Proceed to Test Step 4.
- **Not OK** – Recalculate the value and re-enter the correct value into the ECM. **STOP.**

Test Step 4. Inspect the Speedometer Calibration.

Determine the speedometer's vehicle speed calibration setting. You may be required to contact the OEM dealer or you may be required to send the vehicle to the OEM dealer for this information.

Expected Result:

The speedometer must be calibrated to one of the following values:

- For "Other Truck Manufacturer" configurations, the value is 18,600 pulses per kilometer (30,000 pulses per mile).
- For "GM Truck Manufacturer" configurations that have SEP00 or newer software, the value is 2,485 pulses per kilometers (4,000 pulses per mile).

The ECM can only provide the signal that is listed above.

Results:

- **OK** – The speedometer is correctly calibrated. **STOP.**
- **Not OK**

Repair: Perform the following diagnostic procedure:

Send the vehicle to the OEM dealer or reprogram the OEM speedometer to the correct setting for the pulses per kilometer (mile).

STOP.

Index

Numerics

0001-11 Cylinder 1 Fault (72).....	99
0002-11 Cylinder 2 Fault (72).....	99
0003-11 Cylinder 3 Fault (73).....	100
0004-11 Cylinder 4 Fault (73).....	100
0005-11 Cylinder 5 Fault (74).....	101
0006-11 Cylinder 6 Fault (74).....	101
0022-13 Check Timing Sensor Calibration (42) ..	102
0030-08 Invalid PTO Throttle Signal (29)	102
0030-13 PTO Throttle Sensor Calibration (29)....	102
0041-03 8 Volt Supply Above Normal (21)	103
0041-04 8 Volt Supply Below Normal (21).....	103
0042-11 Injection Actuation Pr Control Valve Driver (18)	103
0043-02 Ignition Key Switch Fault (71).....	104
0064-02 Loss of Engine RPM Signal #2 (34)	104
0064-11 No Pattern on Speed Sensor #2 (34)	104
0070-05 Inlet Air Heater Open Circuit (49).....	105
0070-06 Inlet Air Heater Short Circuit (49).....	105
0071-00 Idle Shutdown Override (01)	105
0071-01 Idle Shutdown Occurrence (47).....	106
0071-14 PTO Shutdown Timer Occurrence (47)..	106
0084-00 Vehicle Overspeed Warning (41).....	106
0084-01 Loss of Vehicle Speed Signal (31)	107
0084-02 Invalid Vehicle Speed Signal (36).....	107
0084-08 Vehicle Speed Out of Range (36).....	107
0084-10 Vehicle Speed Rate of Change (36).....	108
0091-08 Invalid Throttle Signal (32)	108
0091-13 Throttle Sensor Calibration (28)	109
0096-03 Primary Fuel Level Sensor Open Circuit (44)	109
0096-04 Primary Fuel Level Sensor Short Circuit (44)	109
0100-03 Oil Pressure Sensor Open Circuit (24)..	110
0100-04 Oil Pressure Sensor Short Circuit (24)..	110
0100-11 Very Low Oil Pressure (46)	110
0102-00 Boost Pressure Reading Stuck High (25)	112
0102-03 Boost Pressure Sensor Open Circuit (25)	112
0102-04 Boost Pressure Sensor Short Circuit (25)	112
0102-07 Excessive Boost Pressure.....	113
0105-00 High Inlet Manifold Temp Warning (64)..	113
0105-03 Inlet Manifold Temp Sensor Open Circuit (38)	115
0105-04 Inlet Manifold Temp Sensor Short Circuit (38)	115
0105-11 Very High Inlet Manifold Temp (64)	116
0108-03 Atmospheric Pr Sensor Open Circuit (26)	118
0108-04 Atmospheric Pr Sensor Short Circuit (26)	118
0110-00 High Coolant Temperature Warning (61)	118
0110-03 Coolant Temp Sensor Open Circuit (27)	120
0110-04 Coolant Temp Sensor Short Circuit (27)	121
0110-11 Very High Coolant Temperature (61).....	121
0111-01 Low Coolant Level Warning (62)	124
0111-02 Coolant Level Sensor Fault (12).....	125
0111-03 Coolant Level Sensor Open Circuit (12)	126
0111-04 Coolant Level Sensor Short Circuit (12)	126
0111-11 Very Low Coolant Level (62)	127
0128-03 Secondary Fuel Level Sensor Open Circuit (44)	128
0128-04 Secondary Fuel Level Sensor Short Circuit (44)	129
0164-00 Injection Actuation Pr Out of Range (17)	129
0164-02 Injection Actuation Pr Sensor Erratic (15)	130
0164-03 Injection Actuation Pr Sensor Open Circuit (15)	130
0164-04 Injection Actuation Pr Sensor Short Circuit (15)	130
0164-11 Injection Actuation Pressure System (39)	131
0168-02 Intermittent Battery (51)	131
0186-04 PTO Engine Shutdown Short Circuit.....	131
0186-14 PTO Shutdown Switch Occurrence (47)	132
0190-00 Engine Overspeed Warning (35).....	132
0190-02 Loss of Engine RPM Signal (34)	132
0190-11 No Pattern on Speed Sensor #1 (34)....	133
0224-11 Theft Deterrent Active (00)	133
0224-14 Engine Cranking with Theft Deterrent Active (00)	134
0231-02 J1939 Required Data Not Received (58)	134
0231-11 J1939 Data Link Fault (58)	134
0231-12 J1939 Device Not Responding.....	135
0232-03 5 Volt Supply Above Normal (21)	135
0232-04 5 Volt Supply Below Normal (21).....	136
0246-11 Brake Switch #1	136
0247-11 Brake Switch #2	137
0252-11 Incorrect Engine Software (59).....	137
0253-02 Check Customer or System Parameters (56)	137
0253-14 Truck Manufacturer Parameter Not Programed	138
5 Volt Engine Pressure Sensor Supply Circuit - Test	139

A

Accelerator Pedal (Throttle) Position Sensor Circuit - Test	143
Air Inlet Heater Circuit - Test.....	151
ATA (SAE J1587 / J1708) Data Link Circuit - Test	161

C

Calibration Procedures..... 425
 Can Not Reach Top Engine RPM 69
 Probable Causes 69
 Recommended Actions..... 69
 Can Not Reach Vehicle Speed Limit 70
 Probable Causes 70
 Recommended Actions..... 70
 Change Oil Lamp Circuit - Test..... 167
 Check Engine Lamp Circuit - Test 170
 Check Engine Lamp or Warning Lamp Is
 Malfunctioning..... 72
 Check Engine Lamp..... 72
 Cruise Control Set/Resume Switch 73
 Intermittent Diagnostic Codes..... 72
 Probable Causes 72
 Recommended Actions..... 72
 Service Engine Soon Lamp (GM) 73
 Short in Vehicle Harness 73
 Warning Lamp..... 72
 Clutch Pedal Position Switch Circuit - Test 175
 Coolant Level Sensor Circuit - Test 187
 Cooling Fan Circuit and A/C Compressor Clutch
 Circuit - Test..... 196
 Cooling Fan Circuit and A/C High Pressure Switch
 Circuit - Test..... 204
 Cruise Control Parameters 44
 “Cruise/Idle/PTO Switch Configuration” 45
 “Engine Brake Mode” 45
 “High Cruise Control Speed Set Limit” 44
 “Low Cruise Control Speed Set Limit” 44
 “Soft Cruise Control” 45
 Cruise Control Switch Circuit - Test 219
 Cruise Control, Idle, or PTO Can Not Be Set 73
 Customer Specified Parameters 73
 ET Status Screen..... 74
 On/Off switch for Cruise Control and Idle
 Control..... 74
 Probable Causes 73
 Recommended Actions..... 73
 Customer Passwords..... 29
 Customer Specified Parameters..... 35
 Customer Parameter Lockout 35
 Customer Specified Parameters Table 36
 Customer Specified Parameters Worksheet..... 41
 Current Totals Worksheet 44

D

Data Link Parameters..... 46

Dedicated PTO Parameters..... 46
 “Maximum PTO Enable Speed” 48
 “PTO Activates Cooling Fan” 48
 “PTO Active Output ” 49
 “PTO Cab Throttle RPM Limit” 47
 “PTO Configuration” 46
 “PTO Engine RPM Set Speed” 46
 “PTO Engine RPM Set Speed Input A” 47
 “PTO Engine RPM Set Speed Input B” 47
 “PTO Kickout Vehicle Speed Limit ” 48
 “PTO Shutdown Time” 48
 “PTO to Set Speed” 47
 “PTO Top Engine Limit” 46
 “Torque Limit” 48
 Diagnostic Functional Tests..... 139
 Driver Questionnaire..... 76
 Driver Questionnaire Response 77

E

ECM Date/Time Stamped Information..... 29
 Adjustment of ECM Date/Time Clock 30
 ECM Diagnostic Clock 30
 Occurrence of Time Stamped Information 30
 Proper Use of ECM Date/Time Stamped
 Information 30
 ECM Memory - Test..... 233
 ECM Snapshot 30
 Quick Stop Snapshot 31
 Snapshot Information that is Triggered by a
 Diagnostic Code..... 31
 Snapshot Information that Is Triggered
 Externally 31
 Storage of Snapshots in the ECM 32
 Use Of Snapshot..... 30
 ECM Will Not Accept Factory Passwords..... 78
 Incorrect password..... 78
 Incorrect Serial Number 78
 Probable Causes 78
 Reason Code 79
 Recommended Actions..... 78
 Electrical Connectors - Inspect..... 236
 Electronic Service Tool Will Not Communicate with
 ECM..... 79
 Probable Causes 79
 Recommended Actions..... 79
 Electronic Service Tools 20
 Optional Service Tools 21
 Required Service Tools 20
 Electronic Troubleshooting 5
 Elevated Idle 80
 Conditions..... 80
 Probable Causes 80

Engine Cranks but Will Not Start.....	80	Excessive White Smoke	88
Check Communications	81	Air Inlet Restriction.....	89
Combustion Problem	83	Combustion Problem	89
ECM.....	82	Coolant Temperature Circuit	88
ECM Power Supply.....	81	Fuel Supply.....	88
Engine Oil Pressure.....	81	Hydraulic Electronic Unit Injector	89
Engine Protection Devices.....	81	Intake Air Heater	89
Engine Software.....	83	Normal Operation	88
Engine Speed/Timing Signal.....	82	Probable Causes	88
Fuel Supply.....	83	Recommended Actions.....	88
Hydraulic Electronic Unit Injectors	82	Exhaust Brake Circuit - Test	265
Ignition Key Switch.....	81	Exhaust Particulate Filter Circuit - Test.....	271
Injection Actuation Pressure System	83		
Personality Module	82	F	
Probable Causes	80	Factory Passwords	32
Recommended Actions.....	81	Factory Passwords Worksheet	33
Theft Deterrent.....	83	Fast Idle Enable Circuit - Test.....	273
Engine Has Early Wear	83	Fast Idle Lamp Circuit - Test.....	277
Probable Causes	83	Flash Programming	33
Recommended Repairs	83	Fuel Level Sensor Circuit - Test.....	280
Engine Misfires, Runs Rough or Is Unstable	84		
Accelerator Pedal Position Sensor.....	85	G	
Camshaft Position Sensor	85	Glossary	14
Fuel Supply.....	84		
Individual Cylinder Malfunction	84	I	
Low Injection Actuation Pressure.....	85	Idle Parameters	53
Power Train Data Link.....	85	"Fast Idle RPM 1".....	54
Probable Causes	84	"Fast Idle RPM 2".....	54
Recommended Repairs	84	"Idle RPM Limit"	54
Valve Lash	85	"Idle Vehicle Speed Limit"	53
Engine Monitoring Parameters	52	"Idle/PTO Bump RPM"	54
Engine Pressure Sensor Open or Short Circuit - Test.....	243	"Idle/PTO RPM Ramp Rate"	54
Engine Running Output Circuit - Test	251	Idle Shutdown Timer - Test.....	284
Engine Speed/Timing Sensor - Calibrate	425	Ignition Key Switch Circuit and Battery Supply Circuit - Test.....	287
Engine Speed/Timing Sensor Circuit - Test.....	254	Ignore Brake/Clutch Switch Circuit - Test	294
Engine Temperature Sensor Open or Short Circuit - Test.....	260	Important Safety Information	2
Engine Vibration	85	Injection Actuation Pressure - Test	298
Probable Causes	85	Injection Actuation Pressure Control Valve Circuit - Test	303
Recommended Actions.....	85	Injection Actuation Pressure Sensor - Test.....	308
Engine Will Not Crank	86	Injector Solenoid Circuit - Test.....	311
Probable Causes	86	Input Selection Switch Circuit - Test	318
Recommended Actions.....	86	Input Selections	55
Engine Wiring Harness Diagram	26	Intermittent Cruise Control, Idle, or PTO Kickout... ECM Connections	89
Engine/Gear Parameters	49	ET Status Screen.....	89
Excessive Black Smoke.....	87	Probable Causes	89
Air Inlet System or Exhaust System.....	87	Recommended Actions.....	89
ECM or Personality Module	87		
Electronic System	87		
Hydraulic Electronic Unit Injector	87		
Probable Causes	87		
Recommended Actions.....	87		
Valve Lash	87		
Excessive Valve Lash.....	87		
Probable Causes	87		
Recommended Actions.....	88		

Intermittent Engine Shutdown 91
 Aftermarket Engine Protection Devices 91
 Battery Power or Ground to the ECM 91
 ECM or Personality Module 92
 Engine Speed/Timing Sensors 92
 Fuel Supply 91
 Idle Shutdown and Engine Monitoring 91
 Low Injection Actuation Pressure 92
 Probable Causes 91
 Recommended Actions 91
 Intermittent Low Power or Power Cutout 92
 Accelerator Pedal Position Sensor 93
 Battery Power or Ground to the ECM 93
 Electrical Connectors 92
 Electronic System 93
 Engine Monitoring 92
 Fuel Supply 93
 Low Injection Actuation Pressure 94
 Power Train Data Link 93
 Probable Causes 92
 Recommended Actions 92
 Torque Limit Switch 94
 Vehicle Speed Signal 93

L

Low Power/Poor or No Response to Throttle 94
 Accelerator Pedal Position 95
 Air Inlet and Exhaust System 96
 Cold Mode Operation 95
 Customer Specified Parameters 94
 Electronic System 95
 Fuel Supply 96
 Individual Cylinder Malfunction 96
 Low Injection Actuation Pressure 96
 Power Train Data Link 96
 Probable Causes 94
 Recommended Actions 94
 Torque Limit Switch 95
 Vehicle Speed Signal 95

M

Maintenance Parameters 59

N

Neutral Switch Circuit - Test 324
 No Diagnostic Code Detected (55) 99

O

Output Selections 59

P

Passwords 62

Poor Acceleration or Response 97
 Cold Mode Operation 97
 Combustion Problem 98
 Customer Specified Parameters 97
 ECM or Personality Module 98
 Electronic System 97
 Individual Cylinder Malfunction 97
 Injection Actuation Pressure System 98
 Power Train Data Link 98
 Probable Causes 97
 Recommended Actions 97
 Theft Deterrent 98
 Torque Limit Switch 98
 Powertrain Data Link Circuit - Test 337
 Programming Parameters 27
 Programming a New ECM 27
 PTO Engine Shutdown Switch Circuit - Test 345
 PTO Shutdown Timer - Test 349
 PTO Switch Circuit - Test 351
 PTO Switch ON Lamp Circuit - Test 361

R

Remote PTO Accelerator Position Sensor Circuit -
 Test 366

S

Selected Engine Rating 62
 ECM Identification Parameters 62
 "Rating Number" 62
 Sensors and Electrical Connectors 22
 Service Brake Pedal Position (Switch 1) Circuit -
 Test 373
 Service Brake Pedal Position (Switch 2) Circuit -
 Test 385
 Service Information Report 34
 Recommendations 34
 Smart Idle Parameters 62
 Starting Aid Output Circuit - Test 397
 System Configuration Parameters 68
 "Engine Serial Number" 68
 "Full Load Setting" 68
 "Full Torque Setting" 68
 Personality Module Code 68
 "Personality Module Release Date" 68
 System Overview 5
 ECM Lifetime Totals 11
 Effect Of Diagnostic Codes on Engine
 Performance 10
 Engine Monitoring 8
 Engine Snapshot Data 10
 Other ECM Functions of Performance 10
 Passwords 14
 Programmable Parameters 13
 Self-Diagnostics 10
 System Operation 5
 Trip Data that is Stored in the ECM 11

T

Table of Contents..... 3
Tachometer Circuit - Test..... 399
Timer Parameters 64
Transmission (AT/MT/HT) Relay Circuit - Test..... 405
Trip Parameters 62
Troubleshooting Section 5
Troubleshooting with a Diagnostic Code 99
Troubleshooting without a Diagnostic Code 69
Truck Manufacture Parameters..... 64
 “Truck Manufacturer”..... 64
 “Truck Model Type”..... 64

V

Vehicle Speed and Speedometer Circuit - Test... 408
Vehicle Speed Circuit - Calibrate..... 427
Vehicle Speed Parameters 65
 “High Speed Range Axle Ratio”..... 67
 “Low Speed Range Axle Ratio”..... 67
 “Soft Vehicle Speed Limit”..... 67
 “Tachometer Calibration”..... 67
 “Vehicle Speed Cal (J1939 ABS)”..... 66
 “Vehicle Speed Cal (J1939-Trans)”..... 66
 “Vehicle Speed Calibration” 65
 “Vehicle Speed Limit (VSL)”..... 66
 “VSL Protection”..... 67

W

Wait To Start Lamp Circuit - Test..... 417
Warning Lamp Circuit - Test 421

Disassembly and Assembly

3126E Truck Engine

LEF1-Up (Engine)



Important Safety Information

Most accidents that involve product operation, maintenance and repair are caused by failure to observe basic safety rules or precautions. An accident can often be avoided by recognizing potentially hazardous situations before an accident occurs. A person must be alert to potential hazards. This person should also have the necessary training, skills and tools to perform these functions properly.

Improper operation, lubrication, maintenance or repair of this product can be dangerous and could result in injury or death.

Do not operate or perform any lubrication, maintenance or repair on this product, until you have read and understood the operation, lubrication, maintenance and repair information.

Safety precautions and warnings are provided in this manual and on the product. If these hazard warnings are not heeded, bodily injury or death could occur to you or to other persons.

The hazards are identified by the "Safety Alert Symbol" and followed by a "Signal Word" such as "DANGER", "WARNING" or "CAUTION". The Safety Alert "WARNING" label is shown below.



The meaning of this safety alert symbol is as follows:

Attention! Become Alert! Your Safety is Involved.

The message that appears under the warning explains the hazard and can be either written or pictorially presented.

Operations that may cause product damage are identified by "NOTICE" labels on the product and in this publication.

Caterpillar cannot anticipate every possible circumstance that might involve a potential hazard. The warnings in this publication and on the product are, therefore, not all inclusive. If a tool, procedure, work method or operating technique that is not specifically recommended by Caterpillar is used, you must satisfy yourself that it is safe for you and for others. You should also ensure that the product will not be damaged or be made unsafe by the operation, lubrication, maintenance or repair procedures that you choose.

The information, specifications, and illustrations in this publication are on the basis of information that was available at the time that the publication was written. The specifications, torques, pressures, measurements, adjustments, illustrations, and other items can change at any time. These changes can affect the service that is given to the product. Obtain the complete and most current information before you start any job. Caterpillar dealers have the most current information available.



When replacement parts are required for this product Caterpillar recommends using Caterpillar replacement parts or parts with equivalent specifications including, but not limited to, physical dimensions, type, strength and material.

Failure to heed this warning can lead to premature failures, product damage, personal injury or death.

Table of Contents

Disassembly and Assembly Section

Fuel Filter Base - Remove	5	Rear Power Take-Off (RPTO) - Assemble	58
Fuel Filter Base - Install	6	Vibration Damper and Pulley - Remove and Install	62
Fuel Transfer Pump - Remove	6	Crankshaft Front Seal - Remove	63
Fuel Transfer Pump - Install	7	Crankshaft Front Seal - Install	63
Fuel Pressure Regulator - Remove and Install	8	Front Cover - Remove	64
Unit Injector - Remove	9	Front Cover - Install	64
Unit Injector - Install	12	Housing (Front) - Remove	65
Unit Injector Sleeve - Remove	16	Housing (Front) - Install	66
Unit Injector Sleeve - Install	17	Camshaft Idler Gear - Remove and Install	66
Injection Actuation Pressure Control Valve - Remove	17	Valve Mechanism Cover - Remove and Install	68
Injection Actuation Pressure Control Valve - Disassemble	18	Valve Mechanism Cover Base - Remove and Install	70
Injection Actuation Pressure Control Valve - Assemble	18	Rocker Shaft and Pushrod - Remove	71
Injection Actuation Pressure Control Valve - Install	19	Rocker Shaft - Disassemble	72
Unit Injector Hydraulic Pump - Remove	19	Rocker Shaft - Assemble	73
Unit Injector Hydraulic Pump - Install	21	Rocker Shaft and Pushrod - Install	73
Turbocharger - Remove	23	Cylinder Head - Remove	74
Turbocharger - Install	24	Cylinder Head - Install	75
Exhaust Manifold - Remove and Install	24	Lifter Group - Remove and Install	76
Exhaust Particulate Filter - Disassemble	26	Camshaft - Remove	78
Exhaust Particulate Filter - Assemble	28	Camshaft - Install	79
Air Inlet Heater - Remove and Install	29	Camshaft Gear - Remove and Install	80
Air Inlet Heater Solenoid - Remove and Install	30	Engine Oil Pan - Remove and Install	81
Air Inlet Cover - Remove and Install	30	Piston Cooling Jets - Remove and Install	82
Inlet and Exhaust Valves - Remove and Install	31	Pistons and Connecting Rods - Remove	83
Inlet and Exhaust Valve Guides - Remove and Install	32	Pistons and Connecting Rods - Disassemble	84
Inlet and Exhaust Valve Seat Inserts - Remove and Install	34	Pistons and Connecting Rods - Assemble	85
Engine Oil Filter Base - Remove	35	Pistons and Connecting Rods - Install	87
Engine Oil Filter Base - Disassemble	36	Crankshaft Main Bearings - Remove	89
Engine Oil Filter Base - Assemble	37	Crankshaft Main Bearings - Install	90
Engine Oil Filter Base - Install	37	Crankshaft - Remove	91
Engine Oil Pump - Remove	38	Crankshaft - Install	91
Engine Oil Pump - Disassemble	38	Crankshaft Gear - Remove and Install	93
Engine Oil Pump - Assemble	40	Bearing Clearance - Check	94
Engine Oil Pump - Install	41	Atmospheric Pressure Sensor - Remove and Install	95
Water Pump - Remove	42	Coolant Temperature Sensor - Remove and Install	95
Water Pump - Disassemble	43	Engine Oil Pressure Sensor - Remove and Install	96
Water Pump - Assemble	44	Engine Oil Temperature Sensor - Remove and Install	97
Water Pump - Install	45	Injection Actuation Pressure Sensor - Remove and Install	98
Water Temperature Regulator - Remove and Install	46	Speed/Timing Sensor - Remove and Install	99
Flywheel - Remove	47	Boost Pressure Sensor - Remove and Install	100
Flywheel - Install	48	Inlet Air Temperature Sensor - Remove and Install	101
Crankshaft Rear Seal - Remove	49	Idle Pulley - Remove	102
Crankshaft Rear Seal - Install	49	Idle Pulley - Disassemble	102
Crankshaft Wear Sleeve (Rear) - Remove (If Equipped)	51	Idle Pulley - Assemble	103
Crankshaft Wear Sleeve (Rear) - Install	51	Idle Pulley - Install	103
Crankshaft Rear Seal Carrier - Remove and Install	52	Belt Tensioner - Remove and Install	104
Flywheel Housing - Remove and Install	53	Belt Tightener - Remove	104
Rear Power Take-Off (RPTO) - Disassemble	55	Belt Tightener - Disassemble	105
		Belt Tightener - Assemble	105
		Belt Tightener - Install	106
		Fan Drive Mounting Group - Remove and Install	106
		Fan Drive - Remove	108
		Fan Drive - Install	108
		Engine Control Module - Remove and Install	109

Alternator - Remove and Install	109
Electric Starting Motor - Remove and Install	110
Air Compressor - Remove and Install	111
Air Compressor Drive Gear - Remove	114
Air Compressor Drive Gear - Install	115

Index Section

Index	116
-------------	-----

Disassembly and Assembly Section

i01405963

Fuel Filter Base - Remove

SMCS Code: 1262-011

Removal Procedure

Table 1

Required Tools			
Tool	Part Number	Part Description	Qty
A	2P-8250	Strap Wrench Assembly	1

NOTICE

Keep all parts clean from contaminants.

Contaminants may cause rapid wear and shortened component life.

NOTICE

Care must be taken to ensure that fluids are contained during performance of inspection, maintenance, testing, adjusting and repair of the product. Be prepared to collect the fluid with suitable containers before opening any compartment or disassembling any component containing fluids.

Refer to Special Publication, NENG2500, "Caterpillar Tools and Shop Products Guide" for tools and supplies suitable to collect and contain fluids on Caterpillar products.

Dispose of all fluids according to local regulations and mandates.

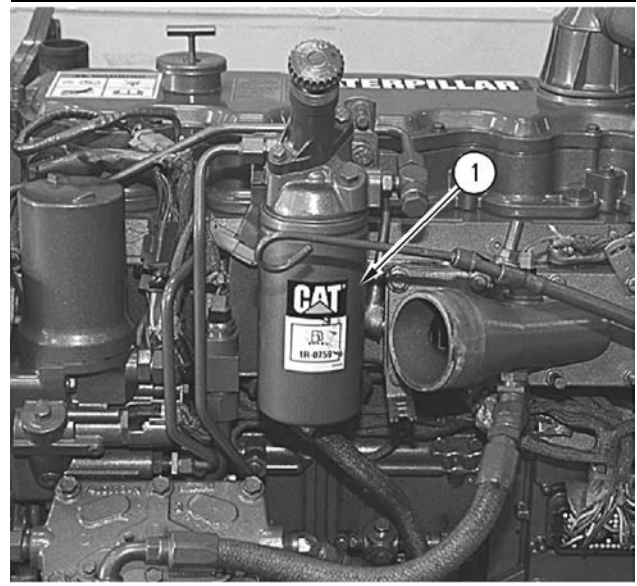

Illustration 1

g00612695

1. Use Tool (A) and remove fuel filter (1).

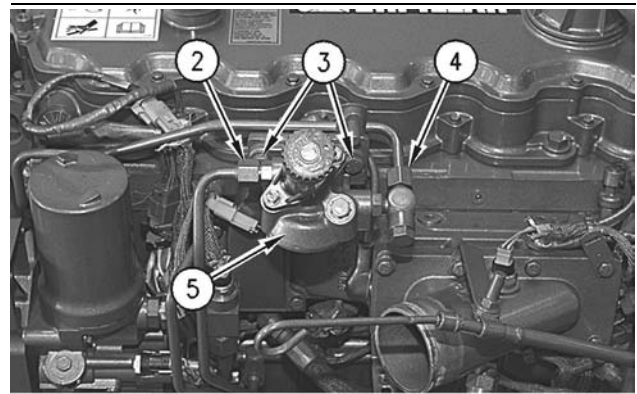

Illustration 2

g00612699

2. Disconnect tube assembly (2) and tube assembly (4) from fuel filter base (5). Immediately cap all openings or plug all openings in order to prevent contamination.
3. Remove bolts (3) that hold fuel filter base (5) to the mounting bracket. Remove fuel filter base (5).

i01405970

Fuel Filter Base - Install

SMCS Code: 1262-012

Installation Procedure

NOTICE

Keep all parts clean from contaminants.

Contaminants may cause rapid wear and shortened component life.

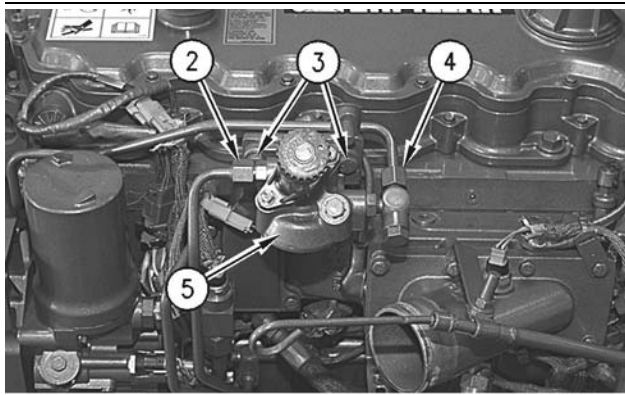

Illustration 3

g00612699

1. Position fuel filter base (5) on the mounting bracket. Install bolts (3).
2. Connect tube assembly (2) and tube assembly (4) to the fuel filter base.

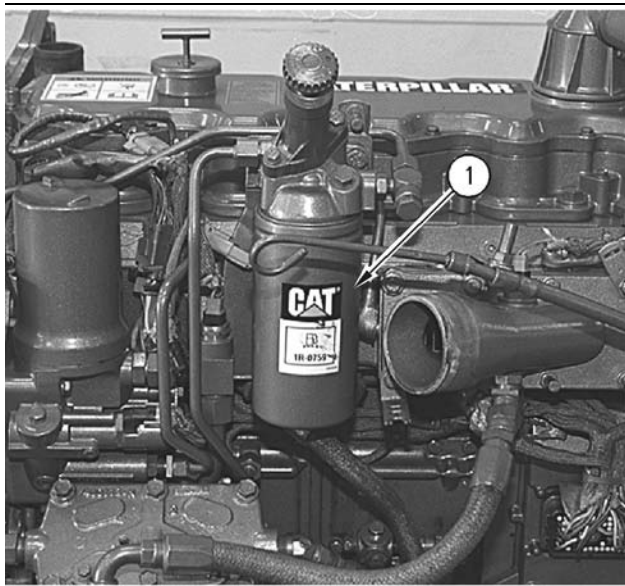

Illustration 4

g00612695

3. Install fuel filter (1). Refer to the Operation and Maintenance Manual, "Fuel System Secondary Filter - Replace" topic for more information.
4. Prime the fuel system. Refer to the Operation and Maintenance Manual, "Fuel System - Prime" topic for more information.

i01153675

Fuel Transfer Pump - Remove

SMCS Code: 1256-011

Removal Procedure

NOTICE

Keep all parts clean from contaminants.

Contaminants may cause rapid wear and shortened component life.

NOTICE

Care must be taken to ensure that fluids are contained during performance of inspection, maintenance, testing, adjusting and repair of the product. Be prepared to collect the fluid with suitable containers before opening any compartment or disassembling any component containing fluids.

Refer to Special Publication, NENG2500, "Caterpillar Tools and Shop Products Guide" for tools and supplies suitable to collect and contain fluids on Caterpillar products.

Dispose of all fluids according to local regulations and mandates.

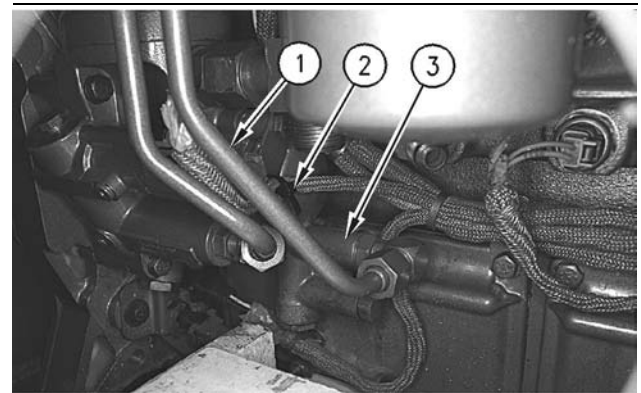

Illustration 5

g00612458

1. Remove fuel outlet line (1) from fuel transfer pump (3). Immediately cap all openings or plug all openings in order to prevent contamination.

- Cut nylon strap (2) that fastens the wiring harness to the unit injector hydraulic pump.

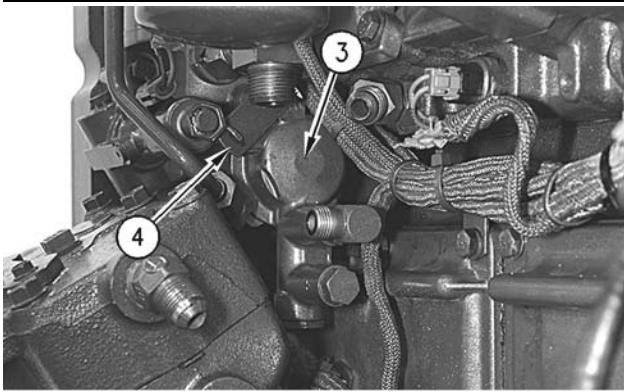

Illustration 6

g00612496

- Remove the bolts, clip (4) and fuel transfer pump (3) from the unit injector hydraulic pump.

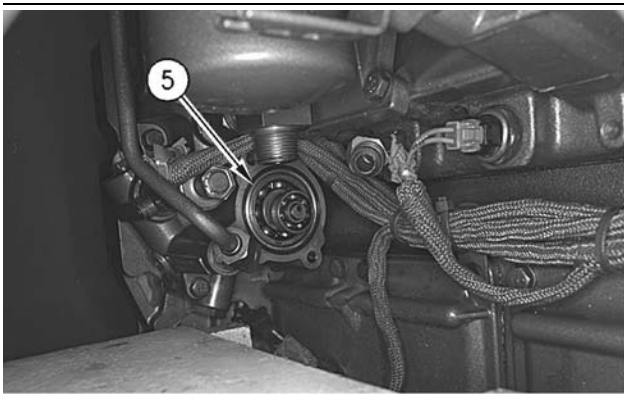

Illustration 7

g00612507

- Remove O-ring seal (5) from the unit injector hydraulic pump. Inspect O-ring seal (5) for wear or damage. If the O-ring seal is worn or damaged, use a new part for replacement.

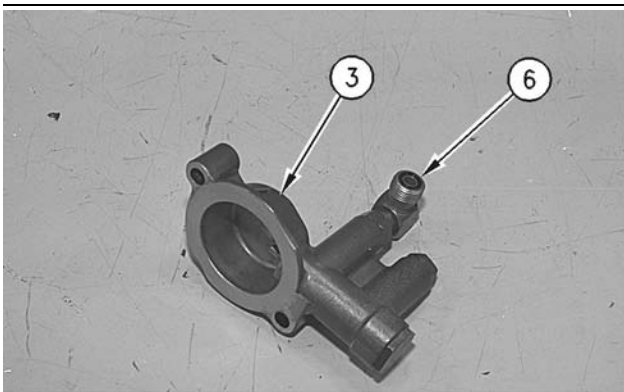

Illustration 8

g00612518

- Remove the elbows for the fuel inlet port and the fuel outlet port from the fuel transfer pump.

- Remove O-ring seal (6) from the elbow. Inspect O-ring seal (6) for wear or damage. If the O-ring seal is worn or damaged, use a new part for replacement.

i01153818

Fuel Transfer Pump - Install

SMCS Code: 1256-012

Installation Procedure

NOTICE

Keep all parts clean from contaminants.

Contaminants may cause rapid wear and shortened component life.

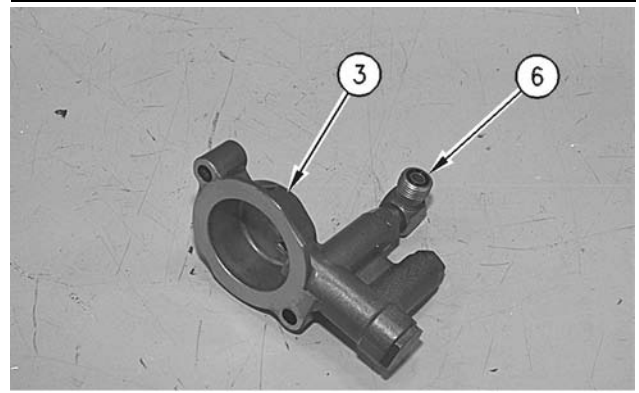

Illustration 9

g00612518

- Clean all components and the mating surfaces. Inspect all components. If any component is worn or damaged, use a new part for replacement. Install the elbows for the fuel inlet port and the fuel outlet port on the fuel transfer pump.
- Install the O-ring seal (6).

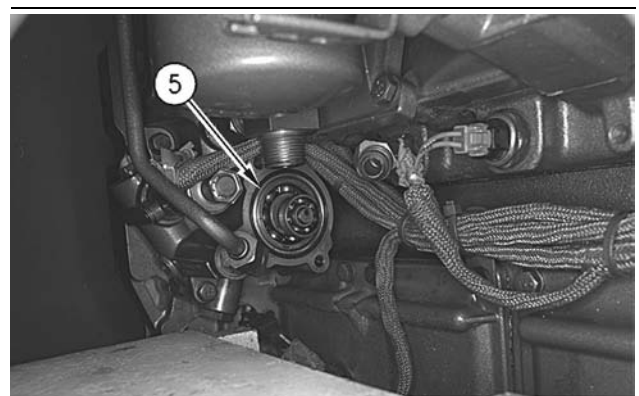

Illustration 10

g00612507

- Install O-ring seal (5) on the unit injector hydraulic pump.

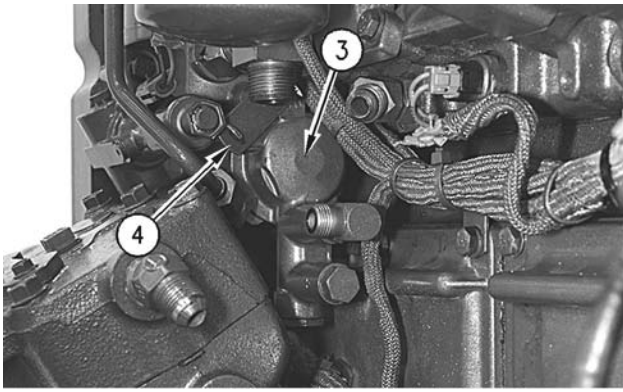

Illustration 11

g00612496

4. Position fuel transfer pump (3) on the unit injector hydraulic pump.
5. Install the bolts and clip (4). Tighten the bolts for the fuel transfer pump to a torque of 25 ± 3 N·m (18 ± 2 lb ft).

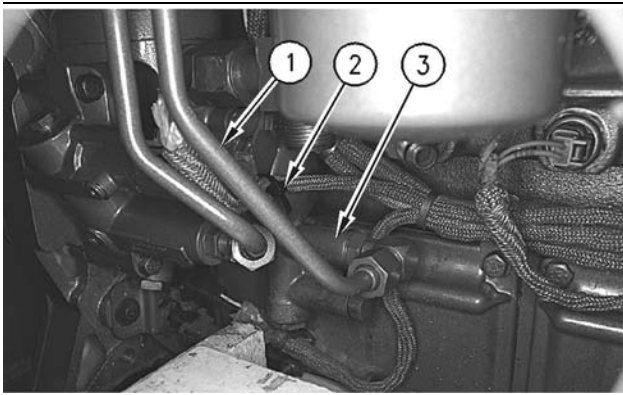

Illustration 12

g00612458

6. Install fuel outlet line (1). Tighten the connectors for the fuel inlet port and the fuel outlet port to a torque of 17.5 ± 2 N·m (13 ± 1.5 lb ft).
7. Secure the wiring harness to the fuel transfer pump with a nylon strap.

Fuel Pressure Regulator - Remove and Install

SMCS Code: 1715-010

Removal Procedure

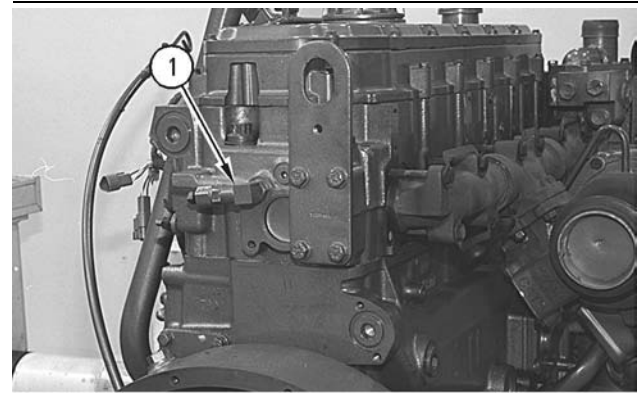

Illustration 13

g00618385

1. Remove fuel pressure regulator (1) from the rear of the cylinder head.

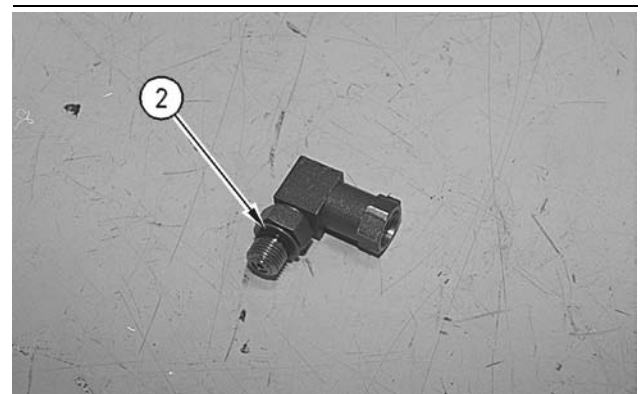

Illustration 14

g00618383

2. Remove O-ring seal (2) from fuel pressure regulator (1).

Installation Procedure

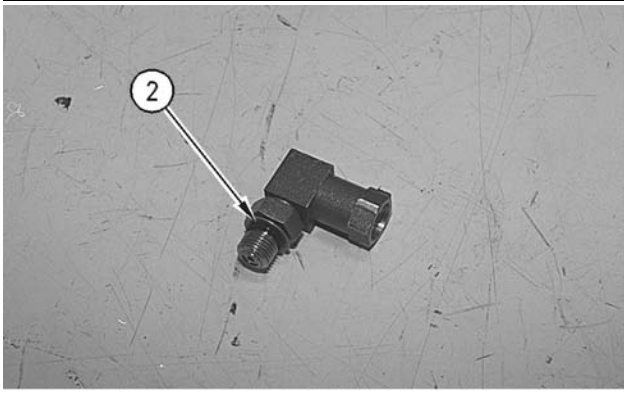

Illustration 15

g00618383

1. Ensure that the orifice in fuel pressure regulator (1) is open and clean. Install a new O-ring seal (2) on fuel pressure regulator (1).

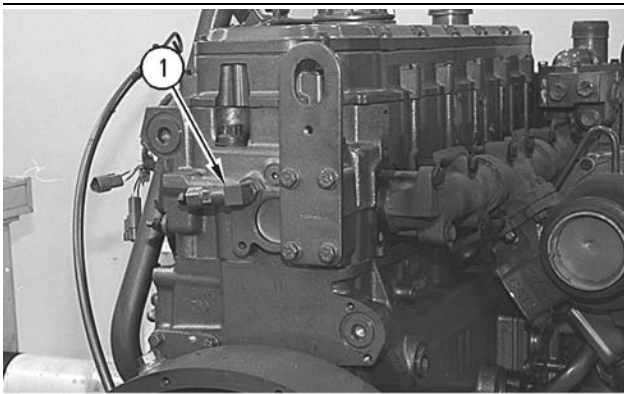

Illustration 16

g00618385

2. Install fuel pressure regulator (1) in the rear of the cylinder head at a 10 degree angle from the horizontal centerline.

i01501703

Unit Injector - Remove

SMCS Code: 1290-011

Removal Procedure

Table 2

Required Tools			
Tool	Part Number	Part Description	Qty
A	1U-7587	Pry Bar	1

Start By:

- a. Remove the valve mechanism cover. Refer to Disassembly and Assembly, "Valve Mechanism Cover - Remove and Install".

NOTICE

Keep all parts clean from contaminants.

Contaminants may cause rapid wear and shortened component life.

NOTICE

Care must be taken to ensure that fluids are contained during performance of inspection, maintenance, testing, adjusting and repair of the product. Be prepared to collect the fluid with suitable containers before opening any compartment or disassembling any component containing fluids.

Refer to Special Publication, NENG2500, "Caterpillar Tools and Shop Products Guide" for tools and supplies suitable to collect and contain fluids on Caterpillar products.

Dispose of all fluids according to local regulations and mandates.

Table 3

Tools For Cleaning Carbon Deposits From The Injector Sleeve Bores		
Part Number	Part Description	QTY
4C-5027	Tap Wrench	1
4C-6161	Tube Brush	1
4C-6774	Vacuum Gun Kit	1
8T-7765	Hand Pad	1
1U-5512	Cut & Polish Roll	1
9U-6102	Reamer	1
9U-6862	Tapered Brush	1

Table 4

Tools For Evacuating Fuel From The Cylinders		
Part Number	Part Description	Qty
4C-4057	Tube	1
1U-5718	Vacuum Pump	1
1U-5814	Bottle Assembly	1

Removal Of The Injector

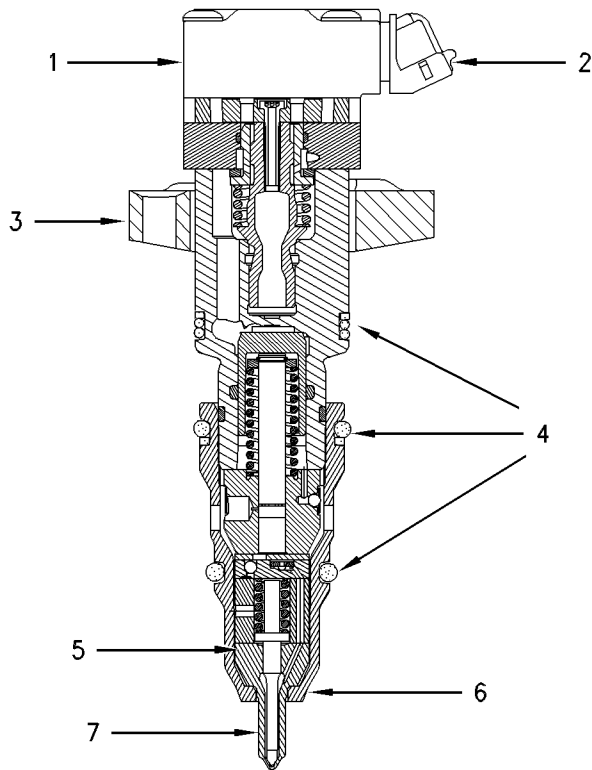

Illustration 17

g00293685

- (1) 128 - 6601 Solenoid Assembly
- (2) Harness Connector
- (3) Clamp
- (4) O-Ring Seals
- (5) 9Y - 9025 Sleeve
- (6) Angled Seat
- (7) 137 - 5621 Tip Assembly

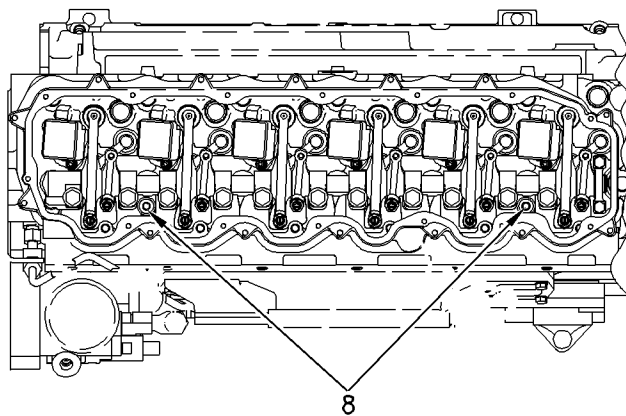

Illustration 18

g00777907

- (8) Oil Drain Plug

1. Remove oil drain plugs (8) at each end of the cylinder head.

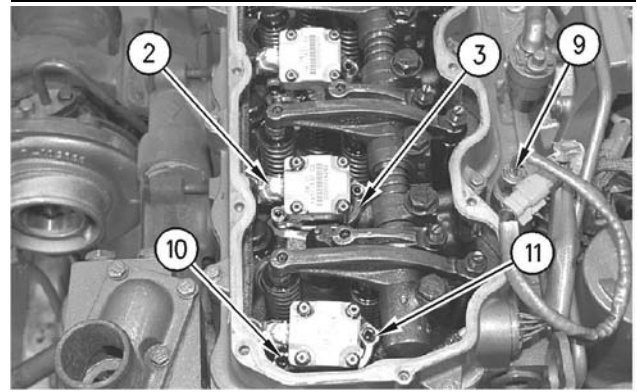

Illustration 19

g00778847

- (2) Wiring Harness Connection
 - (3) Clamp
 - (9) Injection Actuation Pressure Sensor
 - (10) Shoulder Bolt
 - (11) Socket Head Bolt
2. Remove the Injection Actuation Pressure Sensor (9).
 3. Allow the engine oil to drain from the ports in the cylinder head before the injector is removed.
 4. Remove the harness connector (2) away from the injector solenoids.
 5. Remove the Shoulder Bolt (10) and the Socket Head Bolt (11) from the clamp (3).

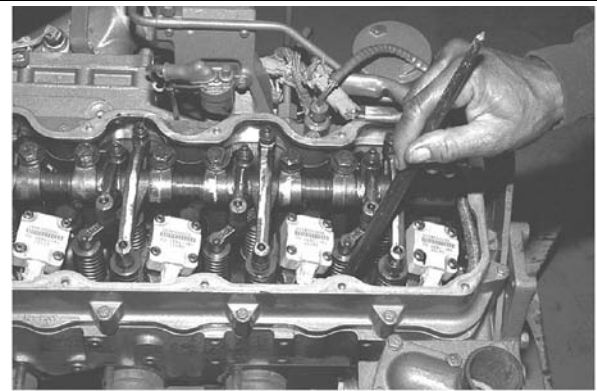

Illustration 20

g00294212

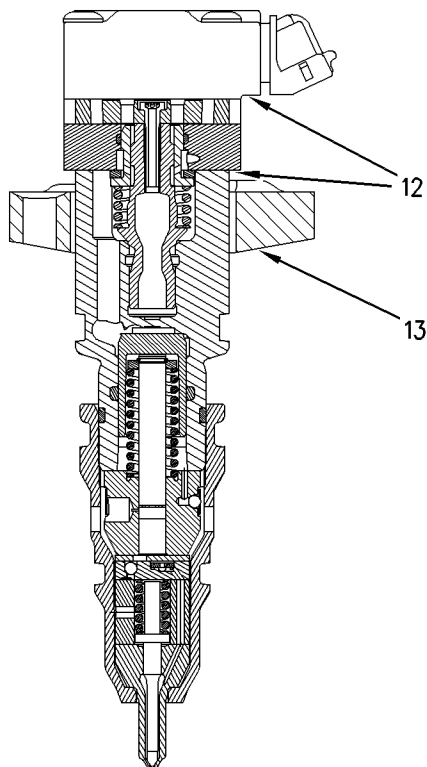

Illustration 21 g00778851

- (12) **Do not pry here.**
- (13) Tool (A) should be placed at this location in order to gently remove the injector.
- 6. Place Tool (A) under the clamp (13) on the flywheel side of the injector.
- 7. Use Tool (A) to remove the injector.

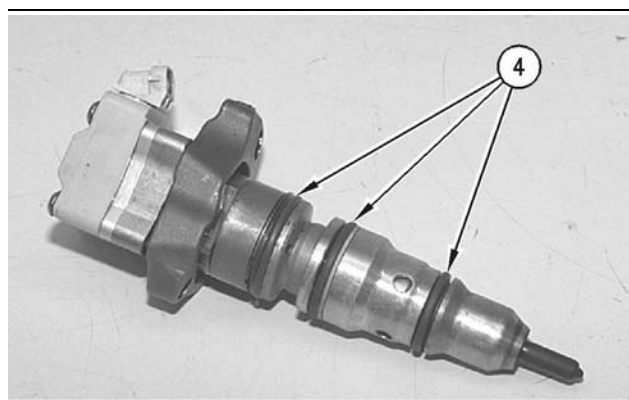

Illustration 22 g00294208

- (4) O-Ring Seals
- 8. Remove the O-Ring seals (4) from the injector.
- 9. Repeat Step 4 through Step 8 for the remainder of the injectors.

Steps For Cleaning The Carbon Deposits

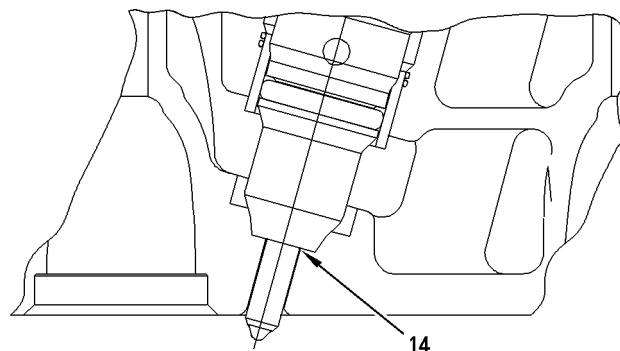

Illustration 23 g00778868
(14) Metal Seal

Cleanliness is very important in the area around the sleeve and the sleeve bore when you are reinstalling the injector. This injector has a metal seal between the bottom of the injector's case and a seat in the cylinder head. Unlike the former designs which were seated against a brass sleeve, this injector seats in the cylinder head. Clean the carbon from the seat area that is inside of the cylinder head. Also clean the carbon from the end of the injector if the injector should be reinstalled.

The fine grade of the Scotch Brite material is preferred. Scotch Brite is available from the Tools And Shop Products Guide as the **1U-5512** Cut & Polish Roll and as the **8T-7765** Hand Pad.

If the sleeve of the injector has been removed from the engine, use a **9U-6102** Reamer to remove carbon deposits from the angled surface.

Note: Do not use the **9U-6102** Reamer in order to remove metal from the sleeve. Use the **9U-6102** Reamer in order to remove carbon only.

If the sleeve of the injector is installed in the engine, use the **4C-6161** Tube Brush to clean the carbon deposits from the inside of the sleeve.

If you choose to clean the angled seat on the injector with a wire brush, the wire brush should not contact the tip of the injector. Failure of the tip and major engine damage may result.

Note: Using power tools in order to rotate the material should not be necessary. The carbon in the sleeve is more removable than the carbon at locations that are exposed to higher temperatures.

The following procedure is the preferred method of cleaning the sleeve bore.

1. Place a 38 mm (1.5 inch) square piece of Scotch Brite material on the end of a **9U-6862** Tapered Brush.

2. Twist the 9U-6862 Tapered Brush with the 4C-5027 Tap Wrench against the lower surface of the sleeve bore.
3. The surface should be cleaned until the surface is smooth and shiny. The entire sleeve bore should be cleaned in order to remove any loose carbon particles.

Note: A 4C-6774 Vacuum Gun Kit is available in order to clean the loose material from the sleeve bore.

Evacuation Of Fuel And Oil From The Cylinder

Evacuate as much fuel and oil as possible from the cylinder before installation of the injector. Use the 1U-5718 Vacuum Pump, 1U-5814 Bottle Assembly, and the 4C-4057 Tube to evacuate the fuel. Several evacuations may be necessary.

i01501732

Unit Injector - Install

SMCS Code: 1290-012

Installation Procedure

Table 5

Required Tools			
Tool	Part Number	Part Description	Qty
A	149-2955	Seal Protector	1
B	149-2956	Seal Installer	1
C	152-1057	Fuel Injector Installer	1

NOTICE

Keep all parts clean from contaminants.

Contaminants may cause rapid wear and shortened component life.

NOTICE

The correct procedures and tooling specifications must always be used. Failure to follow any of the procedures may result in damage, malfunction, or possible engine failure.

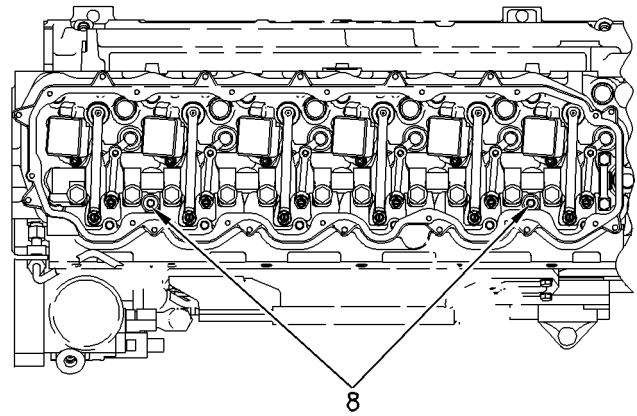

Illustration 24

g0077907

1. Install oil drain plugs (8).

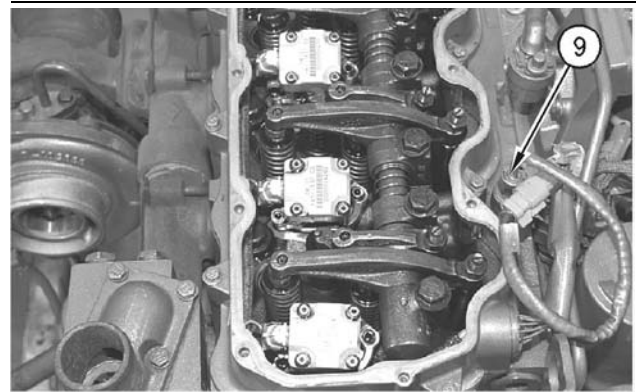

Illustration 25

g00779451

2. Install Injection Actuation Pressure Sensor (9).

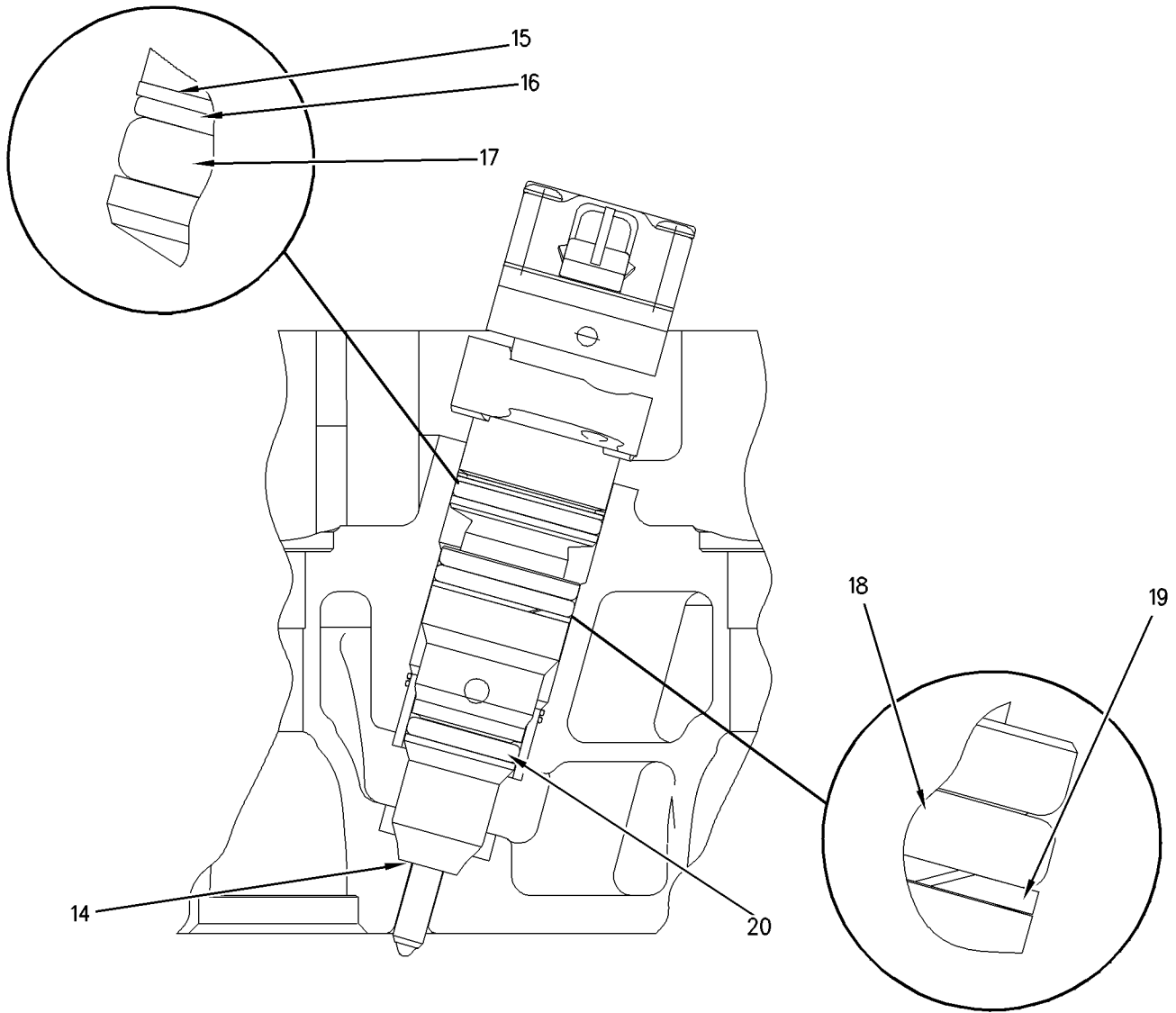

Illustration 26

g00778880

This is an illustration of the 154 - 8016 Fuel Injector Seals.

- (14) Metal Seal
- (15) 133 - 3715 Backup Ring
- (16) 150 - 4105 Backup Ring

- (17) 9X - 7557 O-Ring Seal
- (18) 148 - 2903 O-Ring Seal
- (19) 149 - 5240 Backup Ring

- (20) 109 - 3207 O-Ring Seal

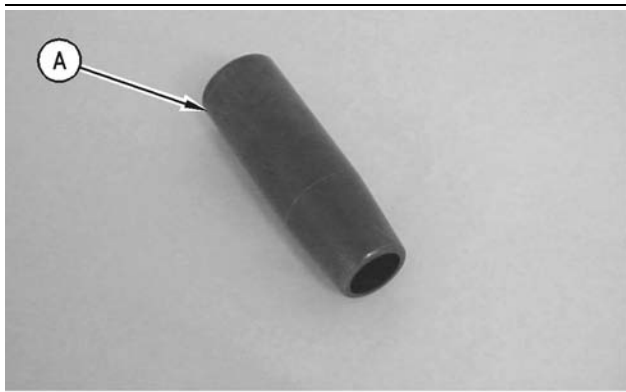

Illustration 27

g00638512

(A) 149-2955 Seal Protector

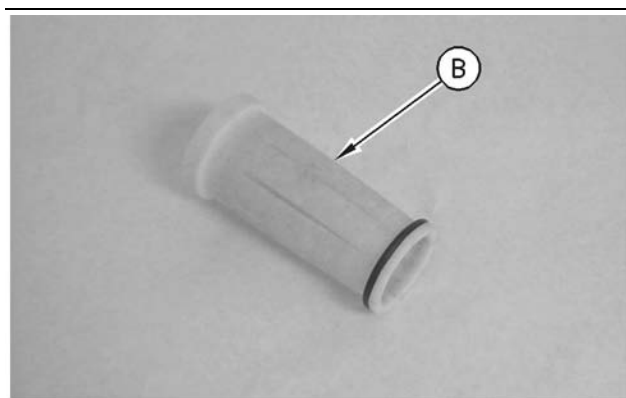

Illustration 28

g00638506

(B) 149-2956 Seal Installer

NOTICE

The correct procedures and tooling specifications must always be used. Failure to follow any of the procedures may result in damage, malfunction, or possible engine failure.

Note: Install the upper seal pack first. Then install the middle seal pack. Finally, install the bottom O-Ring Seal.

- Both the 149-2955 Seal Protector (A) and the 149-2956 Seal Installer (B) should be used when you are installing the upper high pressure seals.

Note: New seals should be installed after each removal of the injector from the engine.

- Lubricate the O-Ring seals and the sleeve bore of the injector sparingly with clean engine oil.

Note: Proper installation of the injector is very important. Damage to the upper high pressure seals can cause excessive oil leakage under the valve cover. This may cause the engine not to start due to a low actuation pressure. Damage to the lower high pressure seals may allow high pressure oil to leak into the fuel supply passage. This will result in excessive oil consumption.

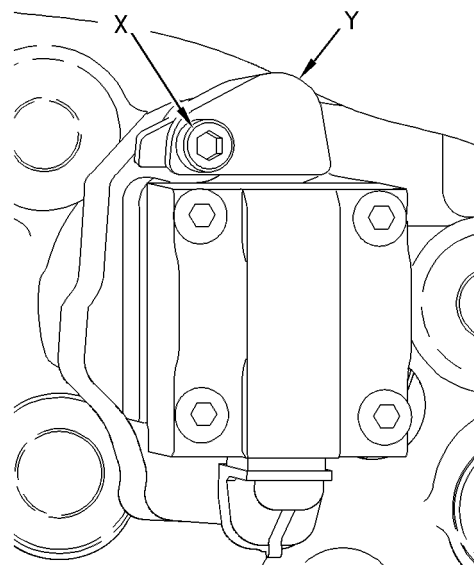

Illustration 29

g00621566

(X) 8T-2396 Bolts.

(Y) 159-0288 Deflector.

Note: Some of these engines were built without the 159-0288 Deflector. During the installation of the unit injectors, the deflectors should be installed. Six 159-0288 Deflectors and six 8T-2396 Bolts are required for each engine. These new deflectors and bolts replace the former 6V-8653 Bolts.



Illustration 30

g00294210

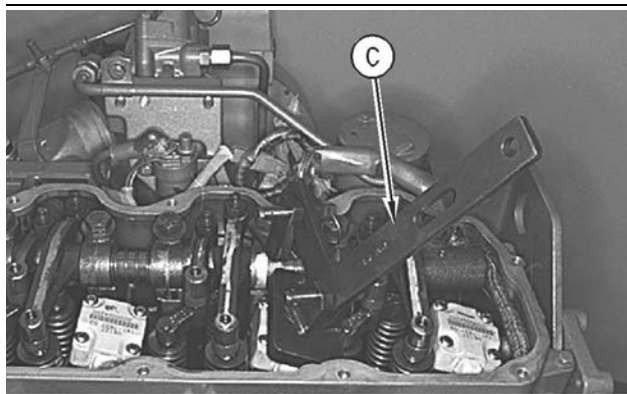

Illustration 31

g00312124

(C) 152-1057 Fuel Injector Installer

- Carefully install the injector into the injector bore. If access permits you to seat the injector, push the injector straight down on top of the injector's solenoid by hand until the injector is firmly seated in the injector bore. Pushing hard enough to compress the injector's seals may be difficult. If the injector can not be seated by hand, use a 152-1057 Fuel Injector Installer (C).

Note: Do NOT pry on the top of the injector with another tool. Do NOT strike the injector with a hammer. Damage to the injector will result. Damage to the injector that is due to improper installation is not a warrantable failure.

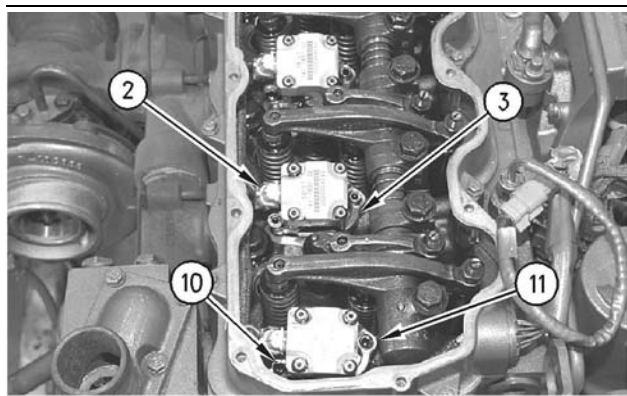

Illustration 32

g00778888

- (2) Wiring Harness Connection
- (3) Clamp
- (10) Shoulder Bolt
- (11) Socket Head Bolt

Note: Do not use the shoulder bolt and the socket head bolt in order to seat the injector. If a side load is placed on the bolts, the bolts may fail.

- After the injector is seated, position the clamp (2) and tighten the Shoulder Bolt (10) to a torque of 6 N·m (50 lb in). Then tighten the Socket Head Bolt (11) to a torque of 12 N·m (9 lb ft).

- Insert the harness connectors (2) back into the injectors' solenoids. Ensure that the clips are snapped back into the proper position.
- Check the system for leaks by using the following procedure.

Check the Fuel System for Leaks

- Visually inspect the components of the injector for oil leaks around the outside diameter.

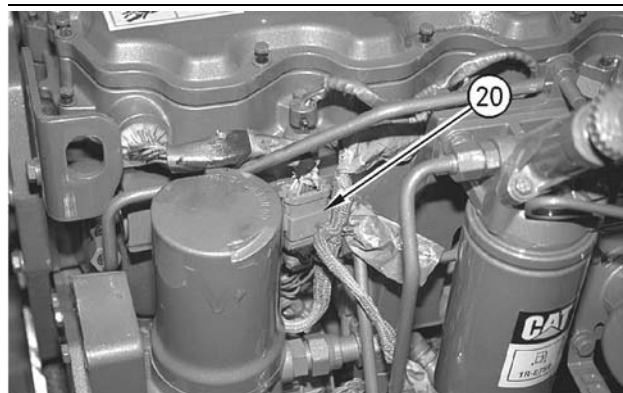

Illustration 33

g00778891

- Disconnect the injector wiring harness with the 12-pin connector (20). The harness is located between the hydraulic pump and the cylinder head. Disconnect the Injection Actuation Pressure Sensor's connector. This will cause the oil pressure to raise to about 2500 psi.
- Crank the engine in order to allow the actuation pressure to rise. Cranking the engine also purges the air from the system.
- Visually check for oil leaks in the area that is between the outside diameter of the injector and the cylinder block.

Note: A small amount of seepage from the injector's vent hole during cranking is normal. A large steady flow from one injector that is greater than the flow from the other injectors may indicate a problem with that injector.

- If no leaks are found, connect the injector wiring harness (20) and the Injection Actuation Pressure Sensor.
- Start the engine.
- Check for oil leaks while the engine is running at idle.
- If no leaks are found, install the ET or other electronic service.

9. Test the actuation pressure. Increase the actuation pressure to the maximum pressure (approximately 3300 psi).
10. If no leaks are found, check the crankcase oil level. Supply the proper amount of oil to the crankcase.

End By:

- a. Install the valve mechanism cover. Refer to Disassembly and Assembly, "Valve Mechanism Cover - Remove and Install".

i01745226

Unit Injector Sleeve - Remove

SMCS Code: 1713-011

Removal Procedure

Table 6

Required Tools			
Tool	Part Number	Part Description	Qty
A	151-4832	Injector Sleeve Tool	1

Start By:

- a. Remove the unit injectors. Refer to Disassembly and Assembly, "Unit Injector - Remove".

NOTICE

Keep all parts clean from contaminants.

Contaminants may cause rapid wear and shortened component life.

NOTICE

Care must be taken to ensure that fluids are contained during performance of inspection, maintenance, testing, adjusting and repair of the product. Be prepared to collect the fluid with suitable containers before opening any compartment or disassembling any component containing fluids.

Refer to Special Publication, NENG2500, "Caterpillar Tools and Shop Products Guide" for tools and supplies suitable to collect and contain fluids on Caterpillar products.

Dispose of all fluids according to local regulations and mandates.

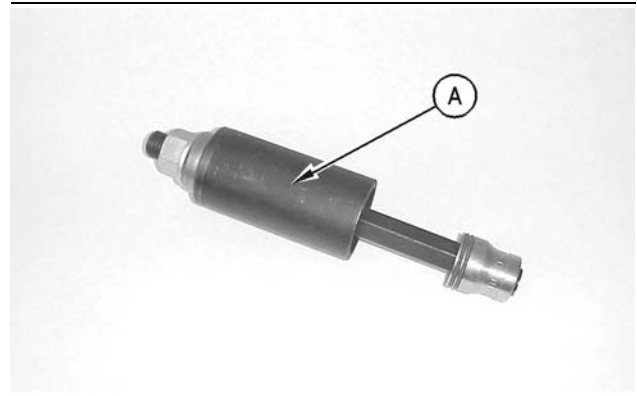

Illustration 34

g00616609

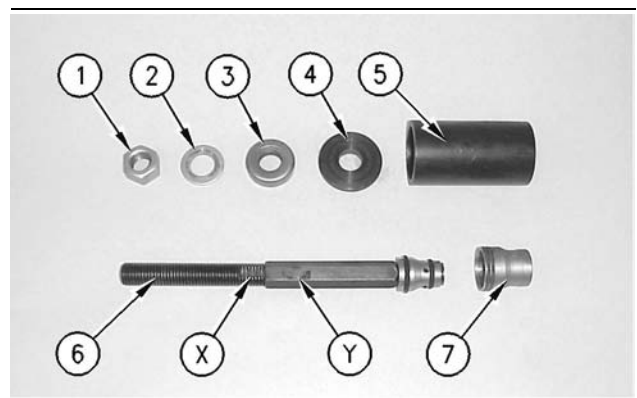

Illustration 35

g00616610

- (1) Nut
- (2) Washer
- (3) Bearing
- (4) Washer
- (5) Sleeve
- (6) Threaded rod assembly
- (7) Unit injector sleeve
- (X) Threaded part of the rod assembly
- (Y) Expandable part of the rod assembly

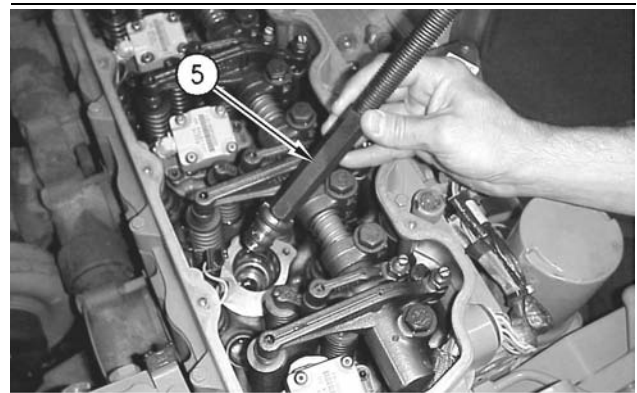

Illustration 36

g00616556

1. Install threaded rod assembly (5) in the unit injector sleeve. Seat expandable part of rod assembly (Y) in the unit injector sleeve. Rotate threaded part of rod assembly (X) in a counterclockwise direction while expandable part of the rod assembly (Y) is held in position.

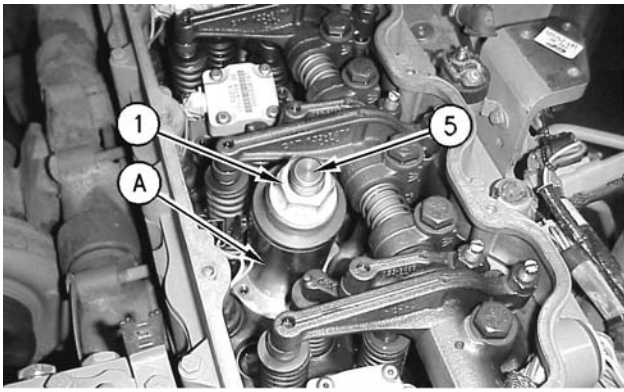

Illustration 37

g00616586

2. Install the remaining parts of Tooling (A) on threaded rod assembly (5).
3. Tighten nut (1) in order to remove unit injector sleeve (7) from the cylinder head.

i01745238

Unit Injector Sleeve - Install

SMCS Code: 1713-012

Installation Procedure

Table 7

Required Tools			
Tool	Part Number	Part Description	Qty
A	150-3152	Sleeve Installer	1

NOTICE

Keep all parts clean from contaminants.

Contaminants may cause rapid wear and shortened component life.

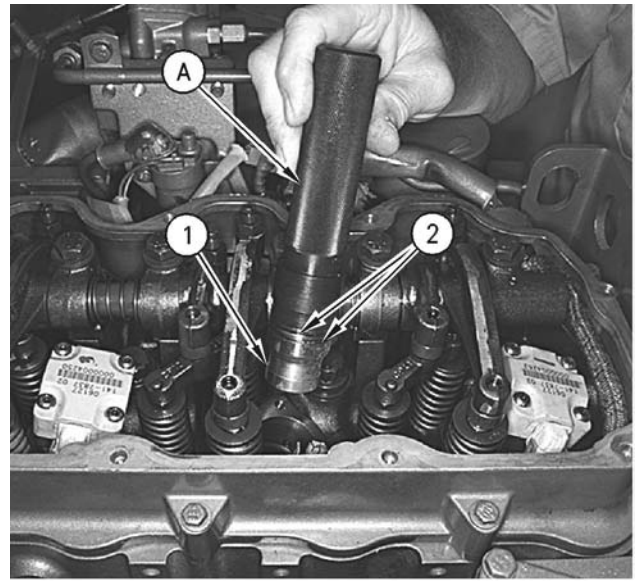

Illustration 38

g00614968

1. Install two new O-ring seals (2) on unit injector sleeve (1).
2. Place unit injector sleeve (1) on Tooling (A).
3. Lubricate the new O-ring seals with clean engine oil and position the unit injector sleeve in the cylinder head.
4. Install unit injector sleeve (1) in the cylinder head with a hammer.

End By:

- a. Install the unit injectors. Refer to Disassembly and Assembly, "Unit Injector - Install".

i01405993

Injection Actuation Pressure Control Valve - Remove

SMCS Code: 5051-011

Removal Procedure

Table 8

Required Tools			
Tool	Part Number	Part Description	Qty
A	5P-0333	Crowfoot Wrench	1

NOTICE

Keep all parts clean from contaminants.

Contaminants may cause rapid wear and shortened component life.

NOTICE

Care must be taken to ensure that fluids are contained during performance of inspection, maintenance, testing, adjusting and repair of the product. Be prepared to collect the fluid with suitable containers before opening any compartment or disassembling any component containing fluids.

Refer to Special Publication, NENG2500, "Caterpillar Tools and Shop Products Guide" for tools and supplies suitable to collect and contain fluids on Caterpillar products.

Dispose of all fluids according to local regulations and mandates.

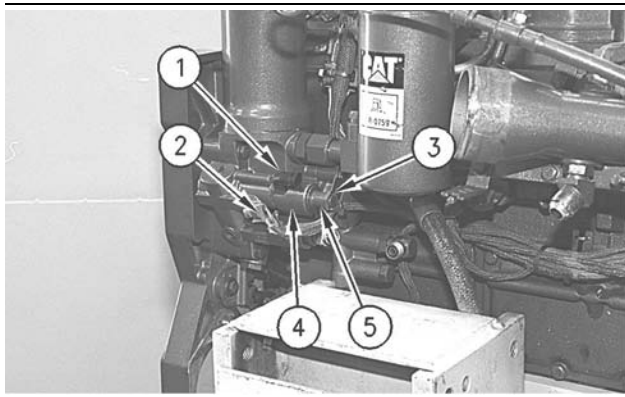

Illustration 39

g00762946

1. Disconnect wiring harness plug (2) from injection actuation pressure control valve (1).
2. Remove nut (3), spacer (5), and solenoid valve (4) from injection actuation pressure control valve (1).
3. Use Tool (A) and an extension in order to remove the injection actuation pressure control valve from the unit injector hydraulic pump.

i01405996

Injection Actuation Pressure Control Valve - Disassemble

SMCS Code: 5051-015

Disassembly Procedure

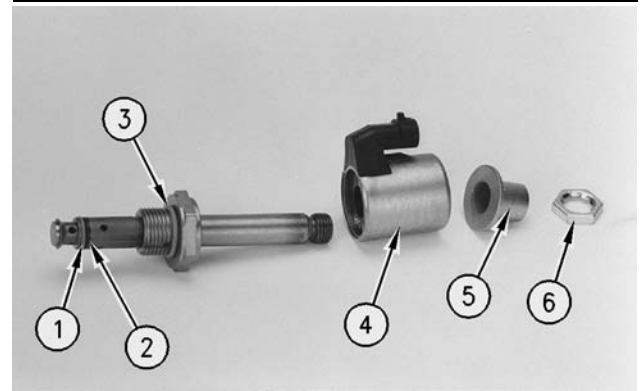

Illustration 40

g00762956

- (4) Solenoid valve
- (5) Spacer
- (6) Nut

1. Remove O-ring seals (3) and (2), and backup ring (1) from the injection actuation pressure control valve. Inspect the components of the injection actuation pressure control valve for wear or damage. If any part is worn or damaged, use a new part for replacement.

i01405998

Injection Actuation Pressure Control Valve - Assemble

SMCS Code: 5051-016

Assembly Procedure

NOTICE

Keep all parts clean from contaminants.

Contaminants may cause rapid wear and shortened component life.

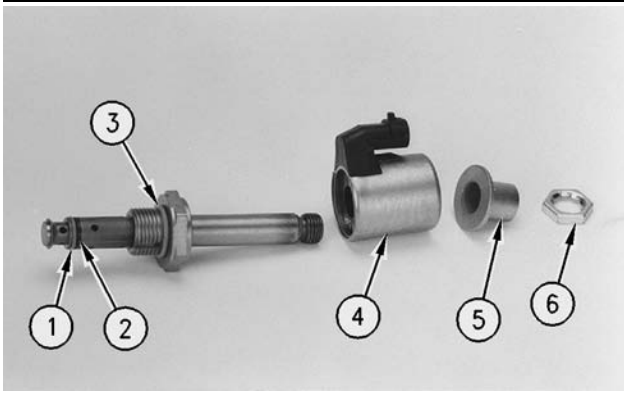

Illustration 41

g00763009

- (4) Solenoid valve
- (5) Spacer
- (6) Nut

1. Clean the injection actuation pressure control valve and the components for the injection actuation pressure control valve.
2. Install new O-ring seals (3) and (2), and backup ring (1) on the injection actuation pressure control valve. Lubricate the O-ring seals with clean engine oil.

i01406008

Injection Actuation Pressure Control Valve - Install

SMCS Code: 5051-012

Installation Procedure

Table 9

Required Tools			
Tool	Part Number	Part Description	Qty
A	5P-0333	Crowfoot Wrench	1

NOTICE

Keep all parts clean from contaminants.

Contaminants may cause rapid wear and shortened component life.

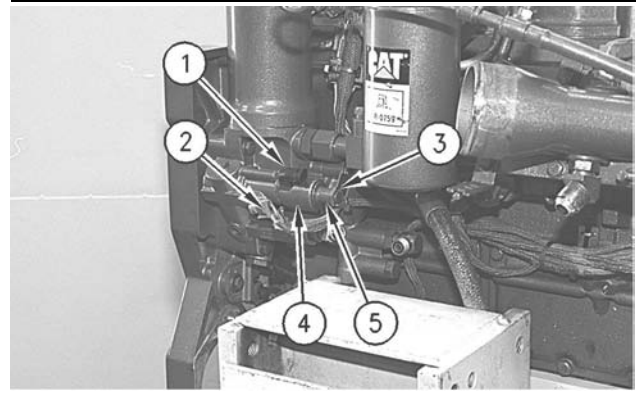

Illustration 42

g00762946

1. Use Tool (A) in order to install the injection actuation pressure control valve on the unit injector hydraulic pump. Tighten the injection actuation pressure control valve (1) to a torque of $50 \pm 5 \text{ N}\cdot\text{m}$ ($37 \pm 4 \text{ lb}\cdot\text{ft}$).
2. Install solenoid valve (4), spacer (5), and nut (3) on the injection actuation pressure control valve (1). Tighten nut (3) to a torque of $5.5 \pm 1.5 \text{ N}\cdot\text{m}$ ($49 \pm 13 \text{ lb}\cdot\text{in}$).
3. Reconnect wiring harness plug (2) to the injection actuation pressure control valve (1).

i01477891

Unit Injector Hydraulic Pump - Remove

SMCS Code: 1714-011

Removal Procedure

Table 10

Required Tools			
Tool	Part Number	Part Description	Qty
A	5P-0327	Crowfoot Wrench	1
B	180-0186	Removal Tool	1

NOTICE

Keep all parts clean from contaminants.

Contaminants may cause rapid wear and shortened component life.

NOTICE

Care must be taken to ensure that fluids are contained during performance of inspection, maintenance, testing, adjusting and repair of the product. Be prepared to collect the fluid with suitable containers before opening any compartment or disassembling any component containing fluids.

Refer to Special Publication, NENG2500, "Caterpillar Tools and Shop Products Guide" for tools and supplies suitable to collect and contain fluids on Caterpillar products.

Dispose of all fluids according to local regulations and mandates.

Note: If the engine is equipped with a 151-0858 Tube then proceed to 1. If the engine is equipped with a 175-3236 Hose Assembly then go to 3.

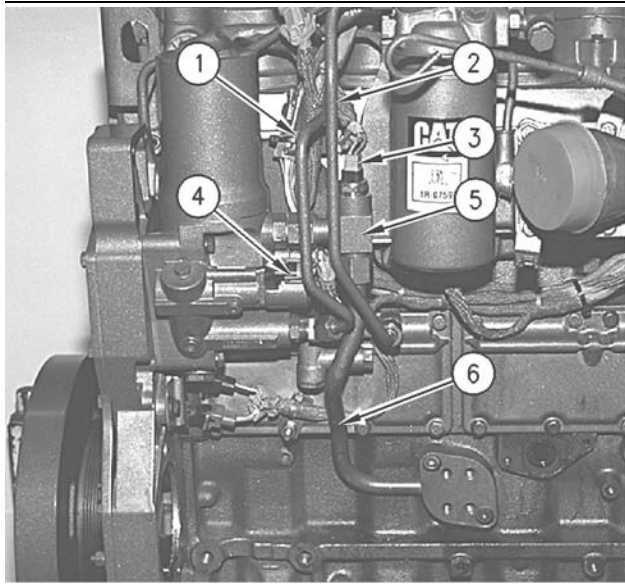

Illustration 43
(Type I) 151-0858 Tube

g00616113

1. Use Tool (A) in order to remove tube (1) and fuel line (2).
2. Disconnect electrical plugs (3) and (4). Proceed to Step 5.

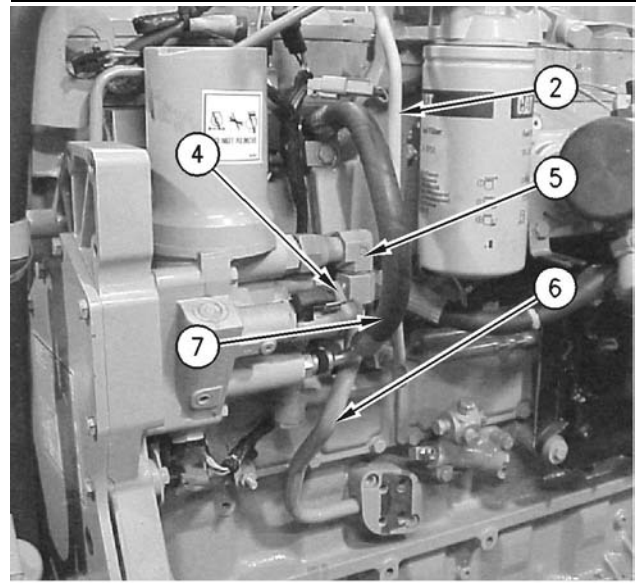

Illustration 44
(Type II) 175-3236 Hose Assembly

g00706904

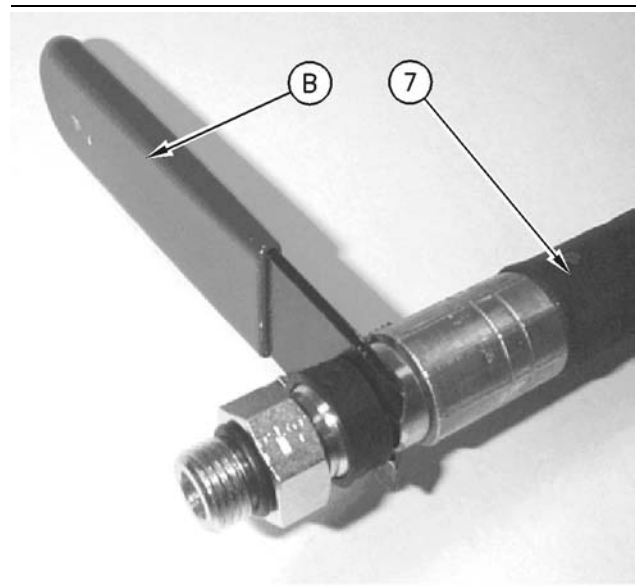

Illustration 45

g00769688

3. Insert Tool (B) on the hose side of the rubber boot on hose assembly (7). Push the rubber boot toward the fitting in order to remove hose assembly (7). Use Tool (A) to remove fuel line (2).

Note: If Tool (B) is not available, screwdrivers that are medium sized may be used. Insert the screwdrivers on each side of the rubber boot and move the rubber boot toward the fitting. This will allow the removal of hose assembly (7).

4. Disconnect electrical plug (4).

i01335912

- Remove return line (6) from the engine block and fitting (5).

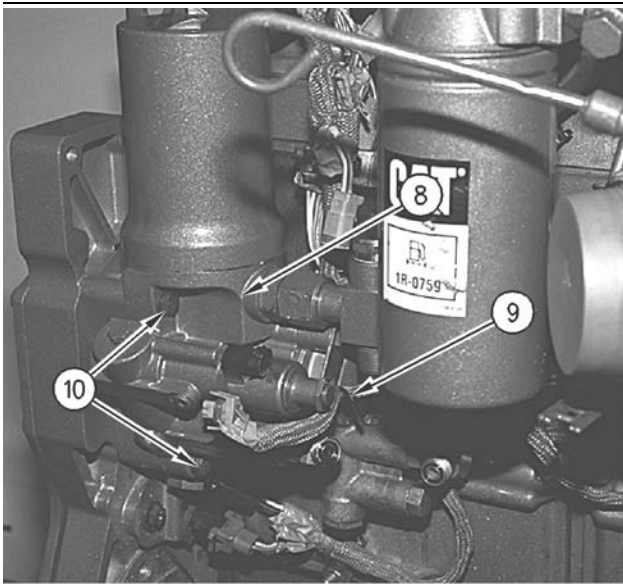

Illustration 46

g00706976

- Cut nylon strap (9) that fastens the wiring harness to unit injector hydraulic pump (8).
- Remove three bolts (10) and remove unit injector hydraulic pump (8) from the timing gear housing.

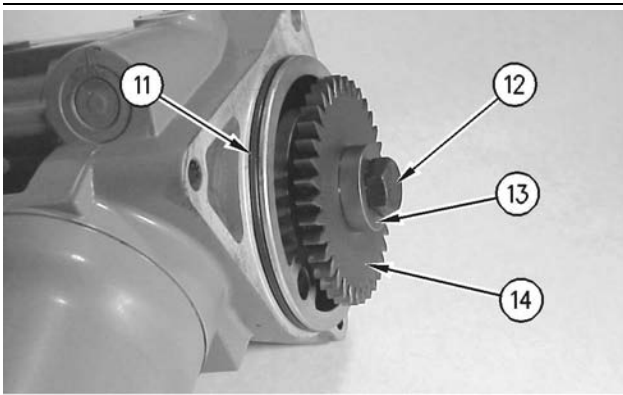

Illustration 47

g00706978

- Remove O-ring seal (11) from unit injector hydraulic pump (8). Inspect the O-ring seal for wear or damage. If the O-ring seal is worn or damaged, use a new part for replacement.
- Remove bolt (12) and washer (13). Remove drive gear (14). Inspect the drive gear for wear or damage. Replace the drive gear, if necessary.

Unit Injector Hydraulic Pump - Install

SMCS Code: 1714-012

Installation Procedure

Table 11

Required Tools			
Tool	Part Number	Part Description	Qty
A	5P-0327	Crowfoot Wrench	1

NOTICE

Keep all parts clean from contaminants.

Contaminants may cause rapid wear and shortened component life.

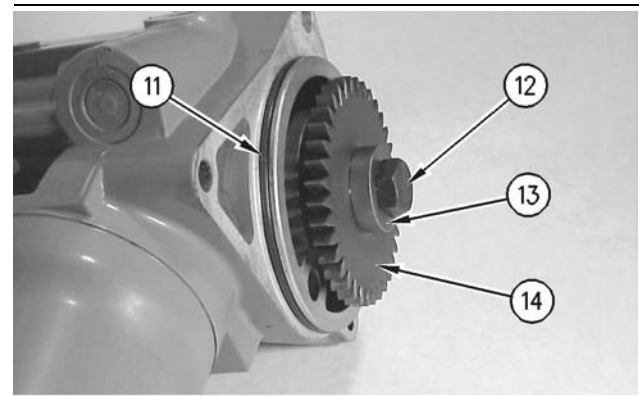

Illustration 48

g00706978

- Position drive gear (14) on the unit injector hydraulic pump. Install bolt (12) and washer (13) on the unit injector hydraulic pump. Tighten bolt (12) to a torque of 110 ± 14 N·m (81 ± 10 lb ft).
- Lubricate O-ring seal (11) with clean engine oil. Install the O-ring seal on the unit injector hydraulic pump.

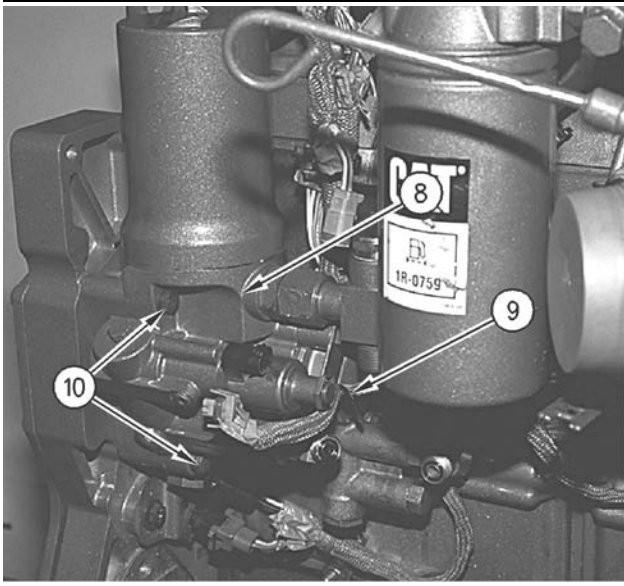

Illustration 49

g00706976

3. Position unit injector hydraulic pump (8) on the timing gear housing. Install three bolts (10) and tighten three bolts (10) to a torque of 28 ± 7 N·m (20 ± 5 lb ft).

Note: If the engine is equipped with a 175-3236 Hose Assembly then go to Step 9. If the engine is equipped with a 151-0858 Tube then proceed with Step 4. If you are converting the engine from 151-0858 Tube to 175-3236 Hose Assembly then go to Step 7.

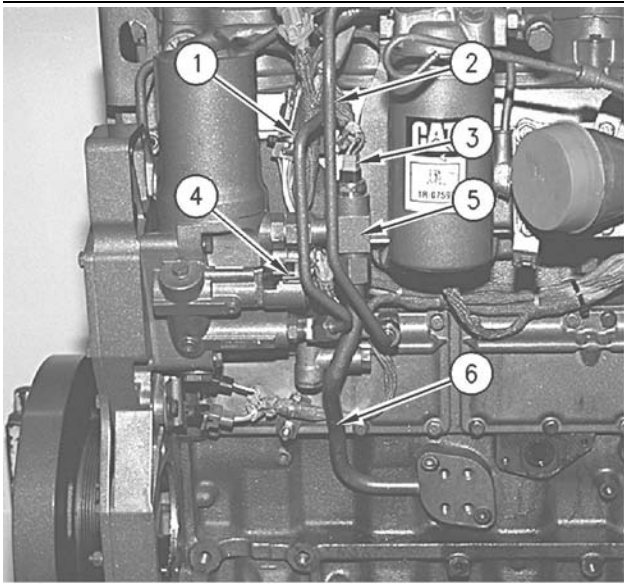

Illustration 50

g00616113

4. Install return line (6) and fitting (5).
5. Install tube (1) and fuel line (2).

6. Secure the wiring harness to the unit injector hydraulic pump with a nylon strap. Connect electrical plugs (3) and (4).

Note: Use the following steps in order to convert the engine from the 151-0858 Tube to the 175-3236 Hose Assembly.

7. Remove the connectors for the 151-0858 Tube that are located in the unit injector hydraulic pump and the cylinder head.
8. Position the 153-4906 O-Ring Seal on the threaded end of each 179-7002 Adapter. Install the adapters in the unit injector hydraulic pump and the cylinder head.

Note: When you replace the 151-0858 Tube with 175-3236 Hose Assembly the fuel supply line must be replaced in order to provide the necessary clearance.

Note: The following steps are for engines that are equipped with the 175-3236 Hose Assembly.

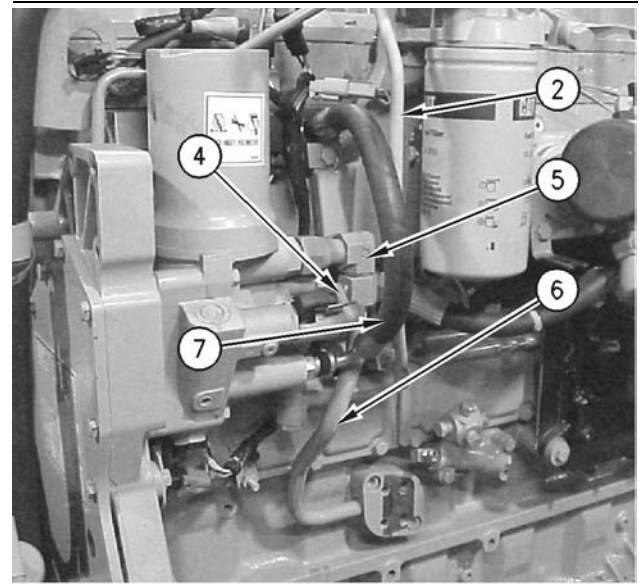

Illustration 51

g00706904

9. Install return line (6) and fitting (5).
10. Reconnect electrical plug (4).

NOTICE

If the hose is not correctly connected the hose will come loose when the engine is started and the engine oil will come out of the hose. Engine damage can result.

NOTICE

Leakage of the high pressure engine oil lines can result in failure of the engine fuel system.

11. Install hose assembly (7) and lock the hose assembly in position. Apply pressure in order to snap the hose assembly into the quick coupling for each of the ends.

Note: Be sure to check the connection by pulling back on the hose.

i01745457

Turbocharger - Remove

SMCS Code: 1052-011

Removal Procedure**NOTICE**

Keep all parts clean from contaminants.

Contaminants may cause rapid wear and shortened component life.

NOTICE

Care must be taken to ensure that fluids are contained during performance of inspection, maintenance, testing, adjusting and repair of the product. Be prepared to collect the fluid with suitable containers before opening any compartment or disassembling any component containing fluids.

Refer to Special Publication, NENG2500, "Caterpillar Tools and Shop Products Guide" for tools and supplies suitable to collect and contain fluids on Caterpillar products.

Dispose of all fluids according to local regulations and mandates.

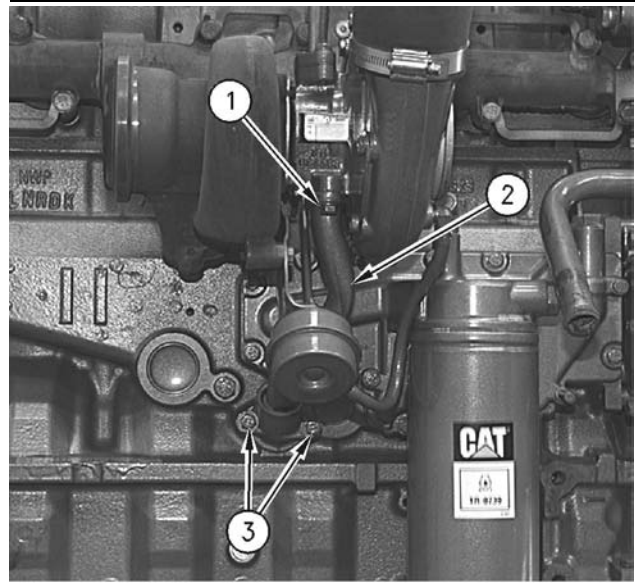

Illustration 52

g00617515

1. Remove bolts (1) and the gasket. Remove bolts (3) and tube assembly (2) from the turbocharger.

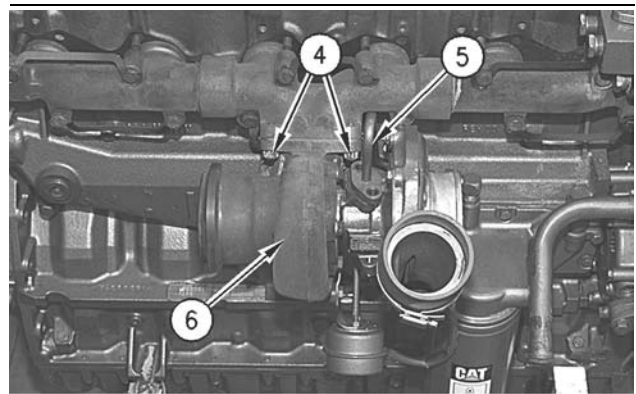

Illustration 53

g00617565

2. Remove the bolts and the gasket in order to disconnect oil supply tube assembly (5) from the turbocharger.
3. Remove four nuts (4), turbocharger (6), and the gasket from the exhaust manifold.

i01334762

Turbocharger - Install

SMCS Code: 1052-012

Installation Procedure

NOTICE

Keep all parts clean from contaminants.

Contaminants may cause rapid wear and shortened component life.

1. Inspect the turbocharger gasket for wear or damage. If the turbocharger gasket is worn or damaged, use a new part for replacement.
2. Apply 5P-3931 Anti-Seize Compound on the threads of the mounting studs for the turbocharger.

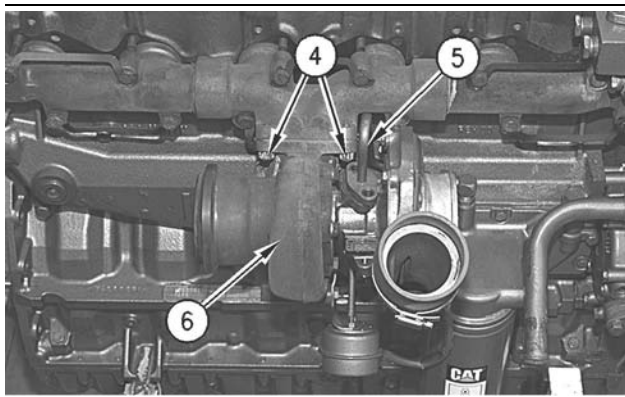

Illustration 54

g00617565

3. Position the turbocharger gasket and turbocharger (6) on the exhaust manifold. Install nuts (4) that fasten turbocharger (6) to the exhaust manifold.
4. Tighten the locknuts that fasten the turbocharger to the exhaust manifold.

Tighten the 3E-8017 Locknut with the Spirallock thread to the following torque: 54 ± 5 N·m (40 ± 4 lb ft)

Tighten the standard 9X-6620 Locknut to the following torque: 70 ± 5 N·m (50 ± 4 lb ft)

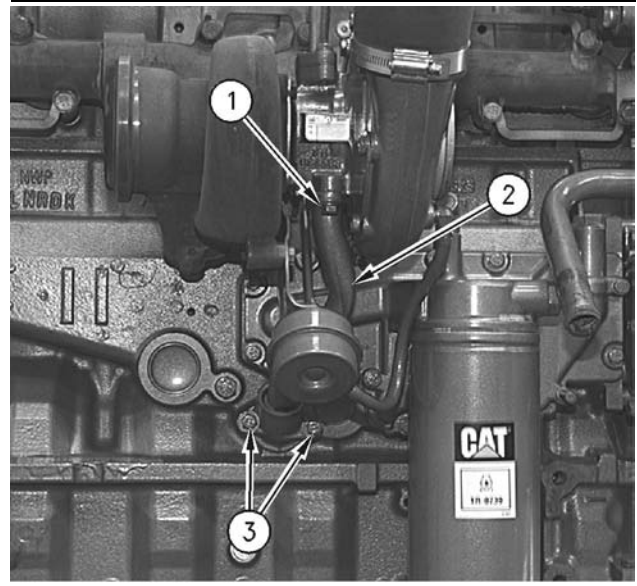

Illustration 55

g00617515

5. Inspect the gaskets for oil supply tube assembly (5) and tube assembly (2). If the gaskets are worn or damaged, use a new part for replacement.
6. Position tube assembly (2) and the gasket on turbocharger (6). Install bolts (1) on the turbocharger and install bolts (3) on the cylinder block.
7. Install the gasket for oil supply tube assembly (5) and connect oil supply tube assembly (5) to turbocharger (6).

i01679487

Exhaust Manifold - Remove and Install

SMCS Code: 1059-010

Removal Procedure

Start By:

- a. Remove the turbocharger. Refer to Disassembly and Assembly, "Turbocharger - Remove".

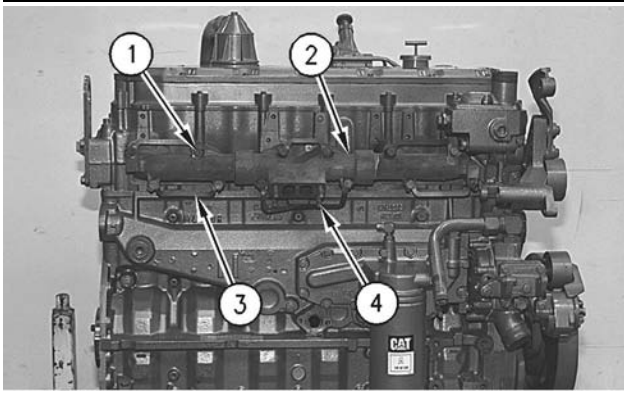

Illustration 56

g00617696

1. Remove bolts (1), locks (3), exhaust manifold (2), and the gaskets from the cylinder head assembly.
2. Disassemble exhaust manifold (2) into three pieces.
3. Remove mounting studs (4) from exhaust manifold (2), if necessary.

Installation Procedure

NOTICE

Excessive use of sealant can cause damage to components.

To avoid component damage use only the amount of sealant necessary for the application.

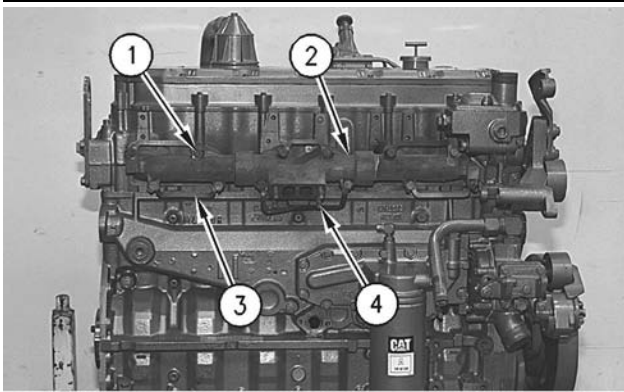

Illustration 57

g00617696

1. Inspect the condition of the gasket. Replace the gasket, if necessary.
2. Mounting surfaces should be clean, and dry. In addition, mounting surfaces should be free of any other foreign matter.

3. Apply 2P-2333 High Temperature Sealer to the outside diameter of the male ends of the exhaust manifold (2). Assemble exhaust manifold (2) and remove the excess sealer from the joints.
4. Apply 5P-3931 Anti-Seize Compound to the threads of bolts (1). Position the gaskets and exhaust manifold (2) on the cylinder head assembly. Install locks (3) and bolts (1).

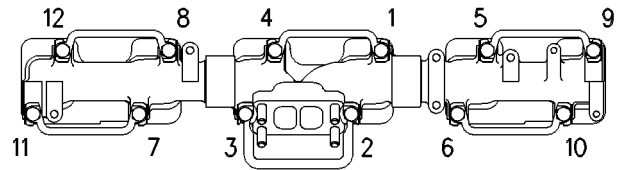

Illustration 58

g00617739

5. Tighten bolt (1) through bolt (12) in a numerical sequence.

Tighten bolts to the following torque. ... 4 ± 1 N·m
(35 ± 9 lb in)

6. Tighten bolt (1) through bolt (12) in a numerical sequence.

Tighten bolts to the following torque. ... 45 ± 5 N·m
(33 ± 4 lb ft)

7. Bend the locking tab over the flat of each bolt head.
8. Apply 5P-3931 Anti-Seize Compound to the threads of mounting studs (4).
9. Install mounting studs (4). Tighten mounting studs (4) to a torque of 35 ± 5 N·m (26 ± 4 lb ft).

Note: Prior to starting or running the engine, allow the sealant in the exhaust manifold joints to air dry for 24 hours.

End By:

- a. Install the turbocharger. Refer to Disassembly and Assembly, "Turbocharger - Install".

i01709977

Exhaust Particulate Filter - Disassemble

SMCS Code: 1091-015

Disassembly Procedure

WARNING

Hot engine components can cause injury from burns. Before performing maintenance on the engine, allow the engine and the components to cool.

WARNING

Climbing equipment may be required to access this service point. Refer to the Operation and Maintenance Manual, "Mounting and Dismounting" topic for safety information.

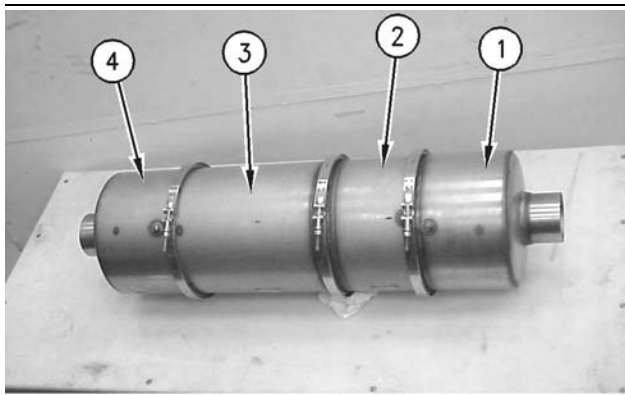

Illustration 59

g00880160

- (1) Inlet module
- (2) Catalyst module
- (3) Filter module
- (4) Outlet module

1. The Diesel Particulate Filter (DPF) is divided into four sections. Each section is secured to the previous section with a clamp and a gasket.

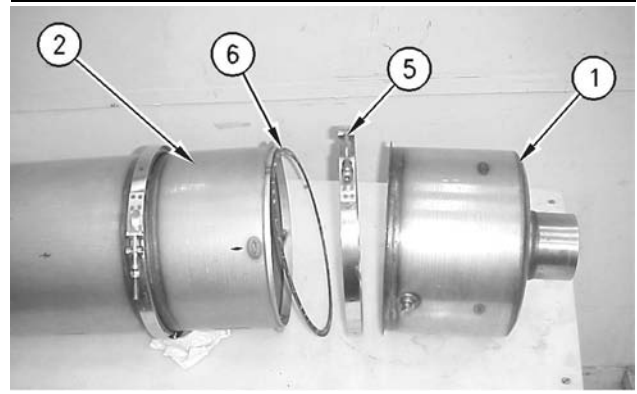

Illustration 60

g00880169

2. Remove clamp (5) and gasket (6).
3. Separate inlet module (1) from catalyst module (2).

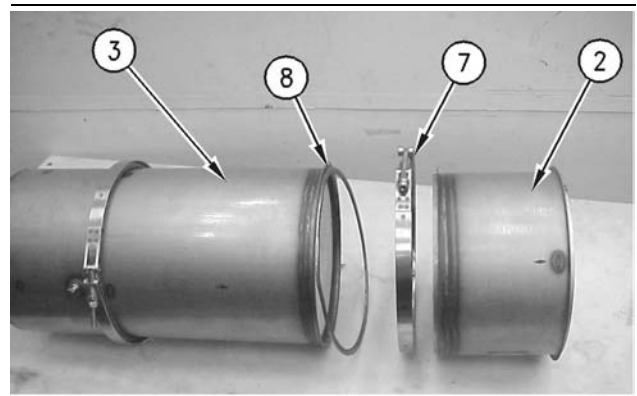

Illustration 61

g00880176

4. Remove clamp (7) and gasket (8).
5. Separate catalyst module (2) from filter module (3).

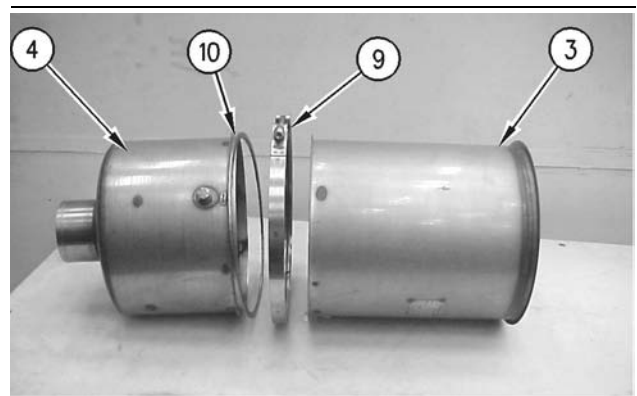

Illustration 62

g00880179

6. Remove clamp (9) and gasket (10).

7. Separate filter module (3) from outlet module (4).
8. Clean the Diesel Particulate Filter (DPF) in the following manner.
 - a. The Diesel Particulate Filter (DPF) can be cleaned.
 - b. Perform a back pressure test in order to determine if the DPF needs to be cleaned.
 - c. Refer to Operation and Maintenance Manual, "Exhaust Particulate Filter - Test".
 - d. The following equipment is required to clean the DPF: dry pressurized air supply with 690 kPa (100 psi), Air nozzle with a short rubber hose on the end of the nozzle, and a way to collect the dust.

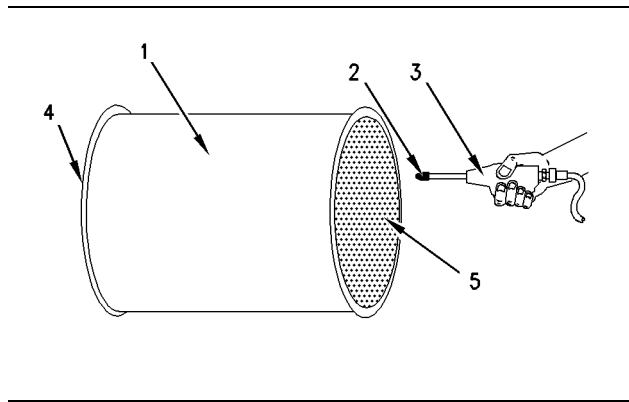

Illustration 63 g00889392

- (1) Filter module
- (2) Rubber hose
- (3) Air nozzle
- (4) Inlet side
- (5) Outlet side

9. Collect the dust from Diesel Particulate Filter (DPF) in the following manner.
 - a. A filter bag is required to collect the ash from the DPF.
 - b. The filter bags are available from your Caterpillar Dealer.
 - c. The filter bag will trap particles as small as 5 microns. A filter bag can be used 5 to 10 times.

Note: Disposal of the filter bags must be in accordance with the following regulations: Federal, State, and Local Laws.

- e. Compressed air 690 kPa (100 psi) will be used to blow the ash from the filter. The air should be dry and free from oil. Attach a short rubber hose onto the end of the nozzle. The rubber hose is used to protect the filter module coating from being hit with the air nozzle.
- f. The air nozzle should be 12.70 mm (0.5 inch) away from the filter. Use slow circular motions to clean the filter. Work from the center of the filter toward the outside. Cleaning the filter module will require 20 to 40 minutes.

10. Perform the cleaning of the Diesel Particulate Filter (DPF) in the following manner.
 - a. Follow the recommended method for cleaning the DPF.
 - b. The filter does not have labels on the inlet or outlet ends of the filter. Mark the outside of the filter with a marker in order to identify the orientation of the filter. This is important due to the installation because you will install the filter in the opposite direction.
 - c. Some installations will allow only the filter module to be removed. The filter module is the only module that is required to be removed.
 - d. Place a filter bag on the inlet side of the filter module.

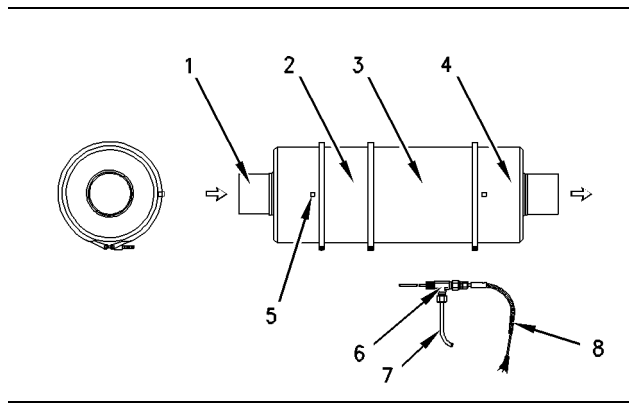

Illustration 64 g00889422

- Typical example
Orientation of the DPF module
- (1) Inlet module
 - (2) Catalyst module
 - (3) Filter module
 - (4) Outlet module
 - (5) Test location
 - (6) Tee fitting
 - (7) Copper tubing
 - (8) Thermocouple

- g. When you install the filter module new gaskets should be used. The filter module should be installed in the opposite direction. Refer to the identification marks that are on the filter. The inlet side of filter should now be outlet side of the filter.
- h. Tighten the clamps to a torque of 20 N·m (15 lb ft).

i01806385

Exhaust Particulate Filter - Assemble

SMCS Code: 1091-016

Assembly Procedure

1. The Diesel Particulate Filter (DPF) is divided into four sections. Each section is secured to the previous section with a clamp and a gasket.

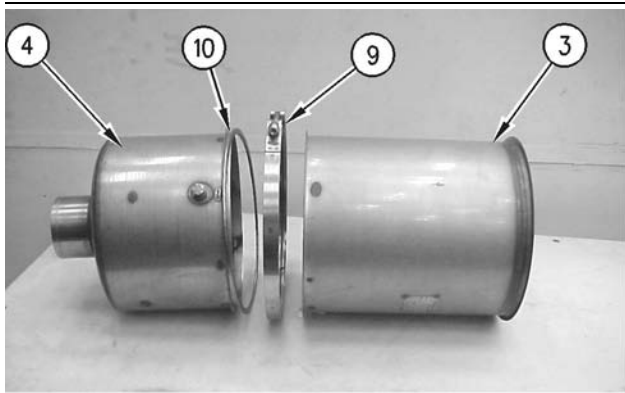

Illustration 65

g00880179

2. Install outlet module (4) next to filter module (3).
3. Secure outlet module (4) to filter module (3) with gasket (10) and clamp (9).

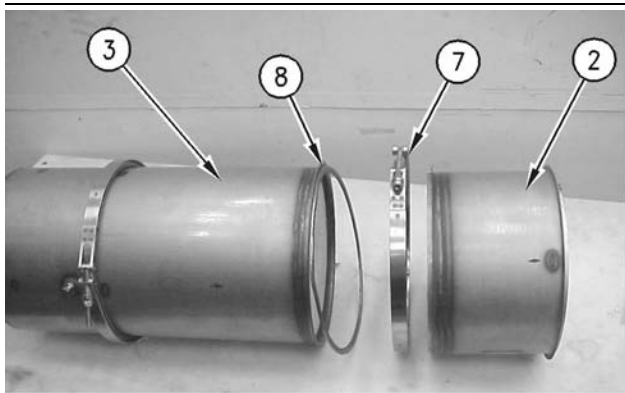

Illustration 66

g00880176

4. Install filter module(3)next to catalyst module (2).
5. Secure filter module (3) to catalyst module (2) with gasket (8) and clamp (7).

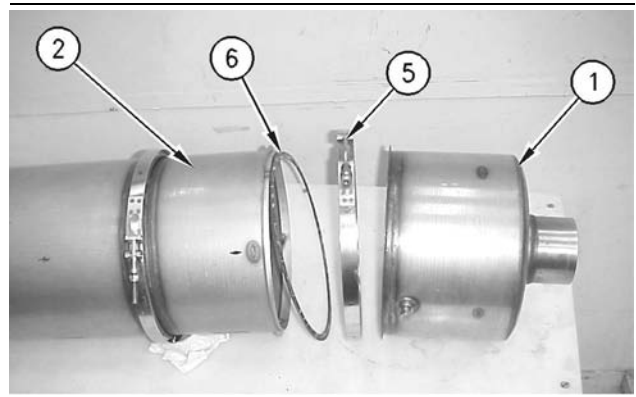

Illustration 67

g00880169

6. Install catalyst module (2) next to inlet module (1).
7. Secure catalyst module (2) to inlet module (1) with gasket (6) and clamp (5).

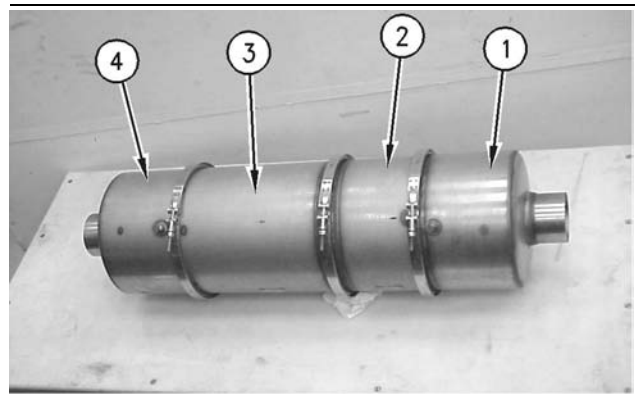

Illustration 68

g00880160

- (1) Inlet module
- (2) Catalyst module
- (3) Filter module
- (4) Outlet module

8. Tighten the clamps to a torque of 20 N·m (15 lb ft).

i01745520

Air Inlet Heater - Remove and Install

SMCS Code: 1090-010

Removal Procedure

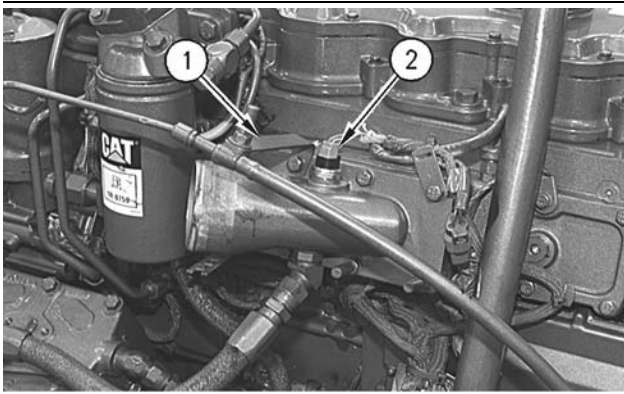

Illustration 69

g00618197

1. Remove oil level gauge (1).
2. Disconnect harness assembly (2) from the air temperature sensor.

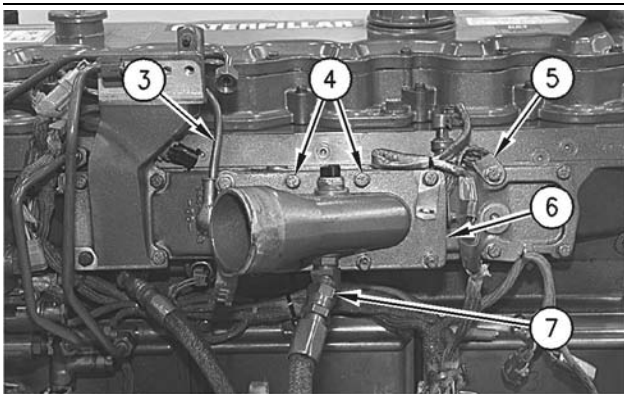

Illustration 70

g00618201

3. Disconnect wire (3) from the solenoid of the air inlet heater.
4. Remove ground strap (5) from the air inlet cover.
5. Remove hose assembly (7) from air inlet elbow (6).
6. Remove eight bolts (4). Remove air inlet elbow (6) and the air inlet heater.

Installation Procedure

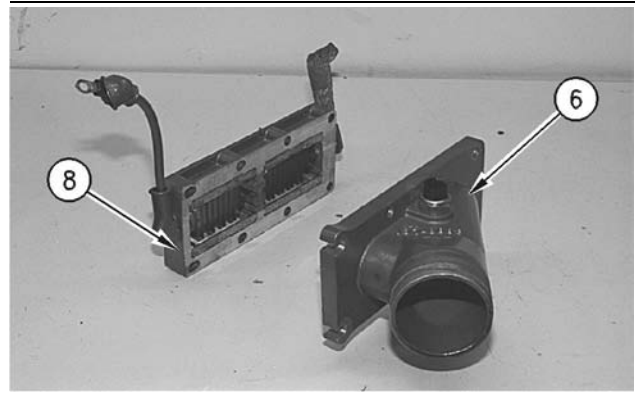

Illustration 71

g00618206

1. Clean the joint face on air inlet heater (8) with solvent. Apply 4C-9500 Quick Cure Primer on the joint face. Allow the primer to air dry for a minimum of three to five minutes.
2. Apply 1U-8846 Sealant to the joint face of air inlet heater (8) and on the joint face of air inlet elbow (6). Air inlet heater (8) and air inlet elbow (6) must be installed within ten minutes of application of the sealant.

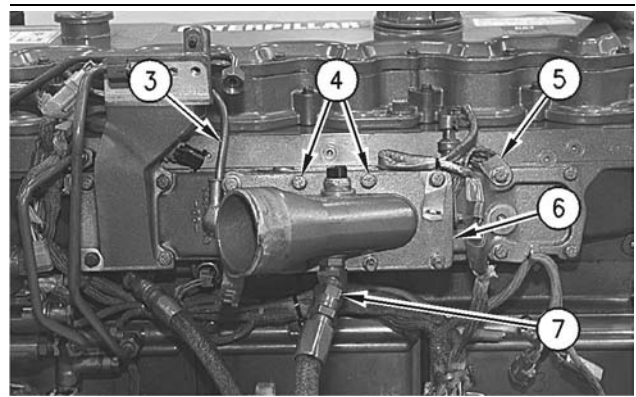

Illustration 72

g00618201

3. Position air inlet heater (8) and air inlet elbow (6) on the air inlet cover.

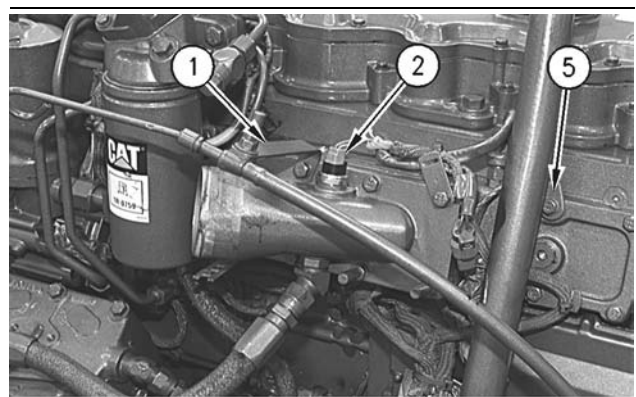

Illustration 73

g00709111

4. Position oil level gauge (1) and install eight bolts (4).
5. Connect ground strap (5) to the air inlet cover.
6. Connect wire (3) to the solenoid of the air inlet heater. Tighten the nut to a torque of 6 ± 0.5 N·m (53 ± 4 lb in).
7. Connect harness assembly (2) to the air temperature sensor.
8. Install hose assembly (7) on air inlet elbow (6).

i01745600

Air Inlet Heater Solenoid - Remove and Install

SMCS Code: 1090-010-OD

Removal Procedure

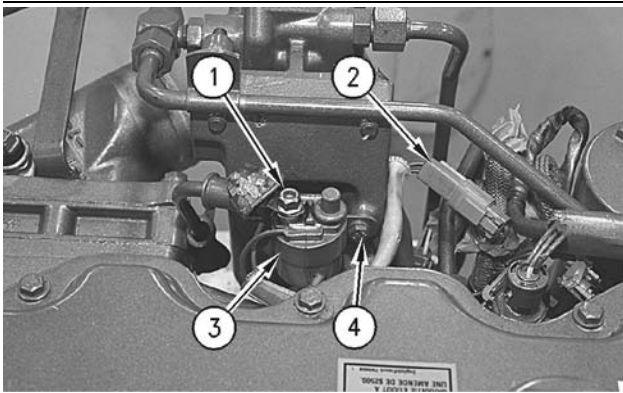

Illustration 74

g00618344

1. Remove nut (1) in order to disconnect the wire assembly from air inlet heater solenoid (3). Disconnect harness assembly (2).
2. Remove two bolts (4) and remove air inlet heater solenoid (3).

Installation Procedure

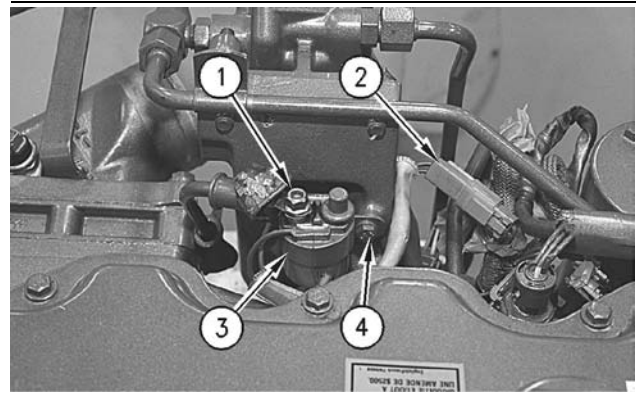

Illustration 75

g00618344

1. Position air inlet heater solenoid (3) and install two bolts (4).
2. Connect the wiring harness (2). Install the wire assembly to air inlet heater solenoid (3). Tighten nut (1) to a torque of 6.0 ± 0.5 N·m (53 ± 4 lb in).

i01745642

Air Inlet Cover - Remove and Install

SMCS Code: 1087-010-CH

Removal Procedure

Start By:

- a. Remove the air inlet heater. Refer to Disassembly and Assembly, "Air Inlet Heater - Remove and Install".
- b. Remove the fuel filter base. Refer to Disassembly and Assembly, "Fuel Filter Base - Remove and Install".

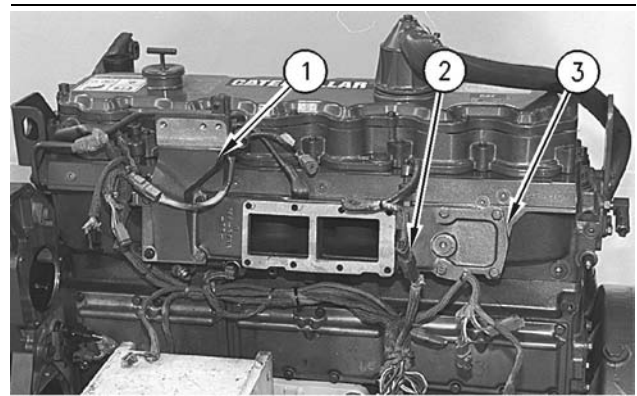

Illustration 76

g00618364

1. Disconnect harness assembly (2) for the boost sensor.
2. Remove four bolts and mounting bracket (1) for the fuel filter base.
3. Remove four bolts and air inlet cover (3).

Installation Procedure

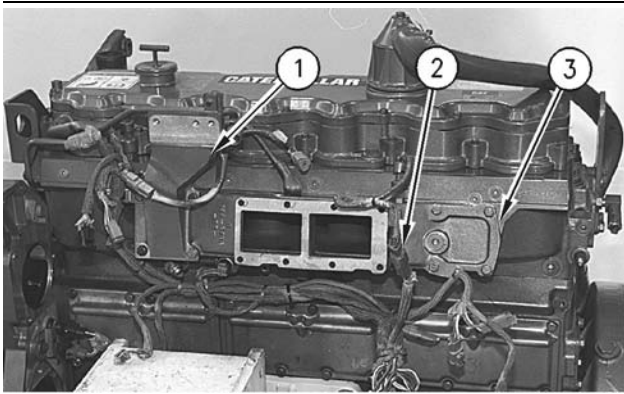

Illustration 77

g00618364

1. Inspect the gasket for air inlet cover (3). Replace the gasket, if necessary.
2. Position air inlet cover (3), mounting bracket (1) for fuel filter base, and the wiring clip on the cylinder head. Install eight bolts.
3. Connect harness assembly (2) for the boost sensor.

End By:

- a. Install the fuel filter base. Refer to Disassembly and Assembly, "Fuel Filter Base - Remove and Install".
- b. Install the air inlet heater. Refer to Disassembly and Assembly, "Air Inlet Heater - Remove and Install".

i01745650

Inlet and Exhaust Valves - Remove and Install

SMCS Code: 1105-010

Removal Procedure

Table 12

Required Tools			
Tool	Part Number	Part Description	Qty
A	5S-1330	Valve Spring Compressor	1

Start By:

- a. Remove the cylinder head assembly. Refer to Disassembly and Assembly, "Cylinder Head - Remove".

NOTICE

Keep all parts clean from contaminants.

Contaminants may cause rapid wear and shortened component life.

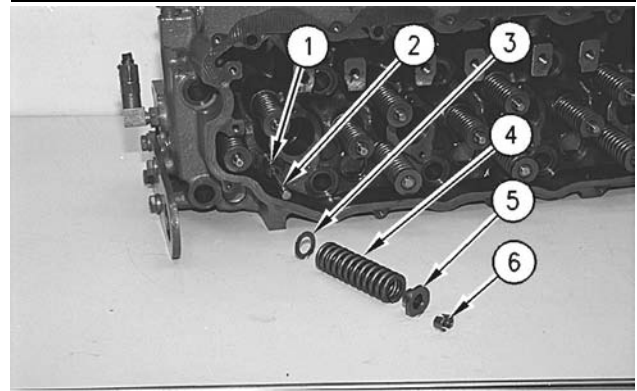

Illustration 78

g00617268

Note: The following components of the exhaust are different from the components of the inlet: spring retainer (5), valve spring (4), and valve (2).

1. Use Tooling (A) to compress valve spring (4). Remove retainer lock (6) and spring retainer (5).
2. Remove Tooling (A). Remove valve spring (4) and washer (3).
3. Remove valve seal (1) and valve (2).
4. Repeat Steps 1 through 3 in order to remove the remaining inlet valves and exhaust valves.

Installation Procedure

Table 13

Required Tools			
Tool	Part Number	Part Description	Qty
A	5S-1330	Valve Spring Compressor	1

NOTICE

Keep all parts clean from contaminants.

Contaminants may cause rapid wear and shortened component life.

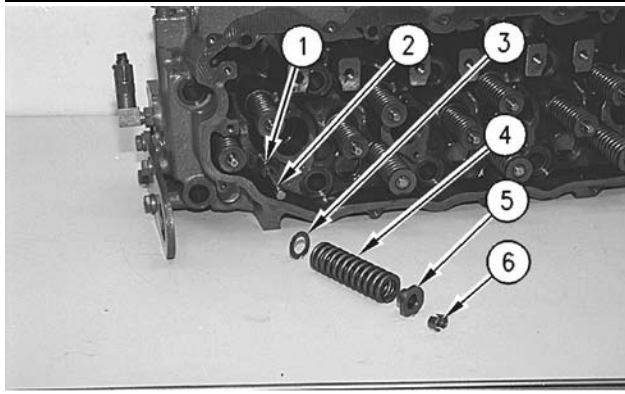

Illustration 79

g00617268

1. Lubricate valve (2) with clean engine oil. Install valve (2) in the cylinder head assembly. Install new valve seal (1) against the valve guide.
2. Place the following items on the valve stem: washer (3), valve spring (4), and spring retainer (5).

! WARNING

The valve keepers can be thrown from the valve when the valve spring compressor is released. Ensure that the valve keepers are properly installed on the valve stem. To help prevent personal injury, keep away from the front of the valve keepers and valve springs during the installation of the valves.

Note: A small amount of grease can be used to hold the retainer locks in position during installation.

3. Use Tooling (A) to compress valve spring (4). Install retainer lock (6).
4. Repeat Steps 1 through 3 in order to install the remaining inlet valves and exhaust valves.

End By:

- a. Install the cylinder head assembly. Refer to Disassembly and Assembly, "Cylinder Head - Install".

Inlet and Exhaust Valve Guides - Remove and Install

SMCS Code: 1104-010

Removal Procedure

Table 14

Required Tools			
Tool	Part Number	Part Description	Qty
A	1U-7793	Valve Guide Driver	1
B	9U-6895	Valve Guide Driver	1

Start By:

- a. Remove the inlet and exhaust valves. Refer to Disassembly and Assembly, "Inlet and Exhaust Valves - Remove and Install".

NOTICE

Keep all parts clean from contaminants.

Contaminants may cause rapid wear and shortened component life.

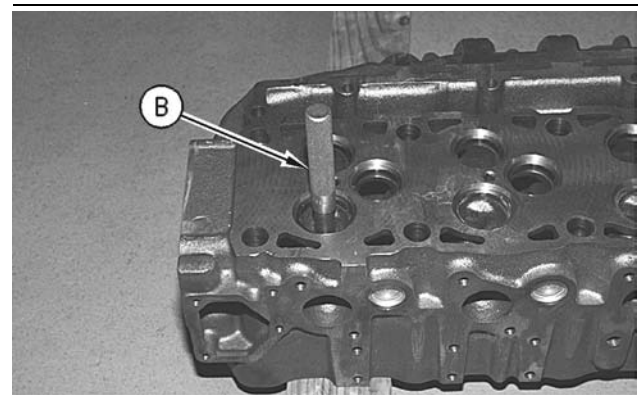

Illustration 80

g00615075

1. Use Tooling (A) to remove the inlet valve guides from the cylinder head assembly. Use Tooling (B) to remove the exhaust valve guides from the cylinder head assembly.

Installation Procedure

Table 15

Required Tools			
Tool	Part Number	Part Description	Qty
A	1U-7793	Valve Guide Driver	1
B	9U-6895	Valve Guide Driver	1
C	1U-7792	Guide Collar	1
D	149-4008	Guide Collar	1

NOTICE

Keep all parts clean from contaminants.

Contaminants may cause rapid wear and shortened component life.

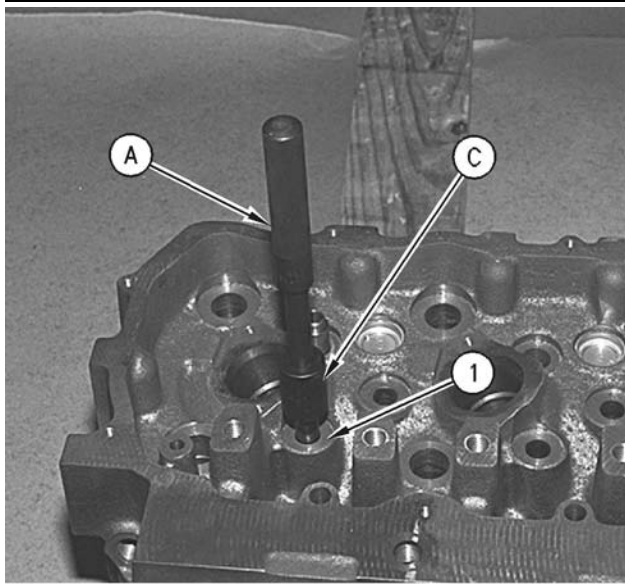

Illustration 81

g00615080

1. Position inlet valve guide (1) and tap on the top of inlet valve guide (1). This is done in order to start inlet valve guide (1) into the cylinder head assembly.
2. Use Tooling (A) and Tooling (C) to install inlet valve guide (1). Install inlet valve guides (1) until the protrusion is 23.0 ± 0.5 mm (0.90 ± 0.02 inch) above the cylinder head assembly.

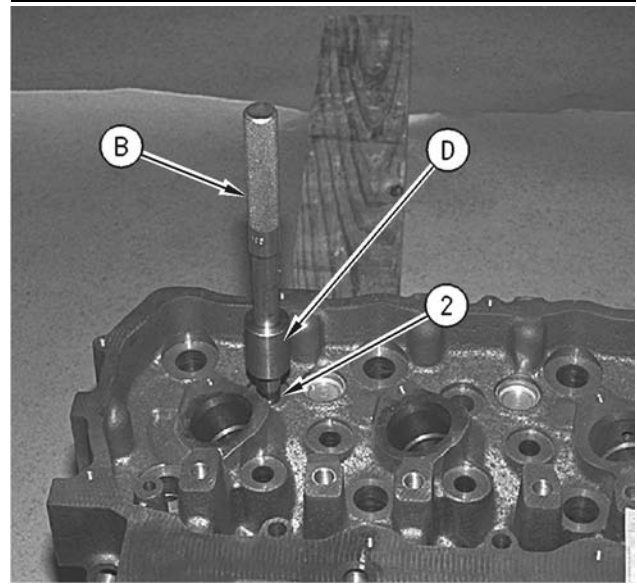

Illustration 82

g00615087

3. Position exhaust valve guide (2) and tap on the top of exhaust valve guide (2). This is done in order to start the exhaust valve guide into the cylinder head assembly.
4. Use Tooling (B) and Tooling (D) to install exhaust valve guide (2). Install exhaust valve guide (2) until the protrusion is 17.8 ± 0.5 mm (0.70 ± 0.02 inch) above the cylinder head assembly.

End By:

- a. Install the inlet and exhaust valves. Refer to Disassembly and Assembly, "Inlet and Exhaust Valves - Remove and Install".

i01745880

Inlet and Exhaust Valve Seat Inserts - Remove and Install

SMCS Code: 1103-010

Removal Procedure

Table 16

Required Tools			
Tool	Part Number	Part Description	Qty
A ⁽¹⁾	6V - 4194	Valve Seat Extractor	1
B ⁽¹⁾	165 - 5647	Valve Seat Extractor	1
C ⁽¹⁾	6V - 4804	Handle	1
D ⁽¹⁾	6V - 4192	Shaft	1
E ⁽¹⁾	6V - 4199	Lifting Bracket	1

⁽¹⁾ Part of the 166 - 7441 Valve Seat Extractor Tool Group

Start By:

- a. Remove the inlet and exhaust valves. Refer to Disassembly and Assembly, "Inlet and Exhaust Valves - Remove and Install".

NOTICE

Keep all parts clean from contaminants.

Contaminants may cause rapid wear and shortened component life.

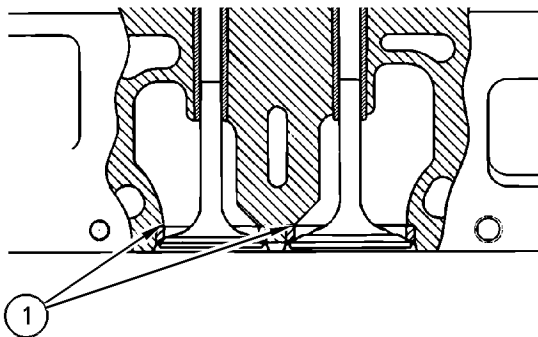

Illustration 83

g00615519

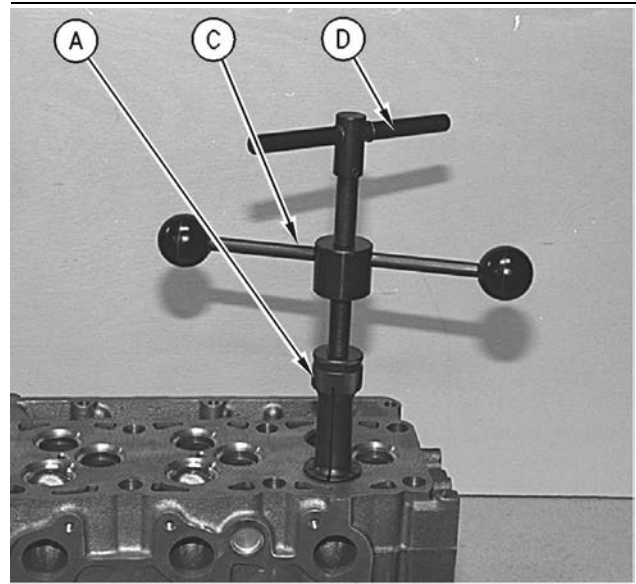

Illustration 84

g00615525

Note: Replace Tooling (A) with Tooling (B) for the removal of the inlet valve seat insert.

1. Install Tooling (A) in the exhaust valve seat insert.
2. Install Tooling (C) and Tooling (D) in Tooling (A). Hand tighten Tooling (D). Tooling (A) will expand below the edge of valve seat insert (1).

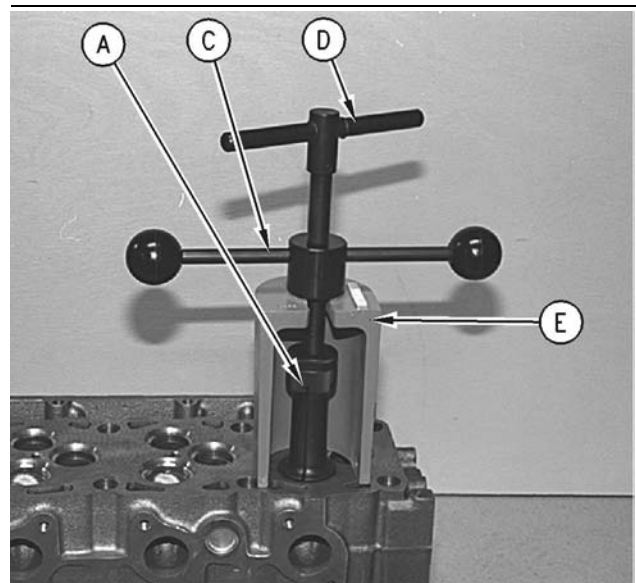

Illustration 85

g00615542

3. Install Tooling (E) on the cylinder head under Tooling (C). Hold Tool (D) while you turn Tooling (C). Remove valve seat (1).

Installation Procedure

Table 17

Required Tools			
Tool	Part Number	Part Description	Qty
A	149-6115	Installer	1
B	133-9306	Valve Guide	1

NOTICE

Keep all parts clean from contaminants.

Contaminants may cause rapid wear and shortened component life.

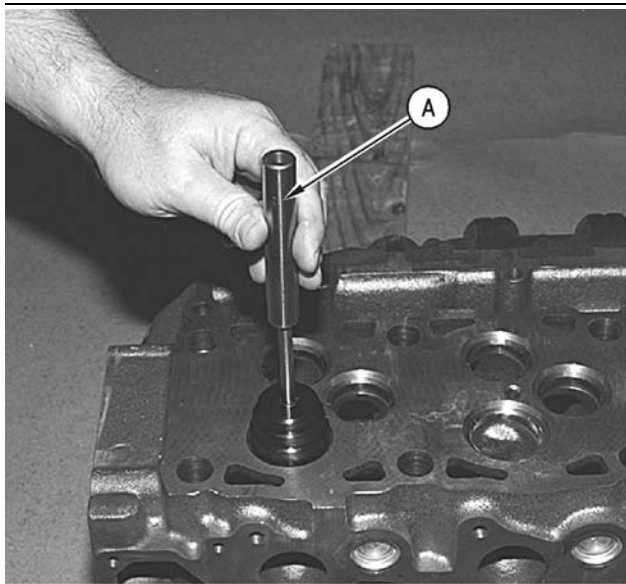

Illustration 86

g00615567

1. Turn Tooling (A) upside-down and use Tooling (A) and a press to install the valve seat inserts in the cylinder head assembly.

End By:

- a. Install the inlet valves and exhaust valves. Refer to Disassembly and Assembly, "Inlet and Exhaust Valves - Remove and Install".

Engine Oil Filter Base - Remove

SMCS Code: 1306-011

Removal Procedure

Table 18

Required Tools			
Tool	Part Number	Part Description	Qty
A	185-3630	Strap Wrench Assembly	1

NOTICE

Keep all parts clean from contaminants.

Contaminants may cause rapid wear and shortened component life.

NOTICE

Care must be taken to ensure that fluids are contained during performance of inspection, maintenance, testing, adjusting and repair of the product. Be prepared to collect the fluid with suitable containers before opening any compartment or disassembling any component containing fluids.

Refer to Special Publication, NENG2500, "Caterpillar Tools and Shop Products Guide" for tools and supplies suitable to collect and contain fluids on Caterpillar products.

Dispose of all fluids according to local regulations and mandates.

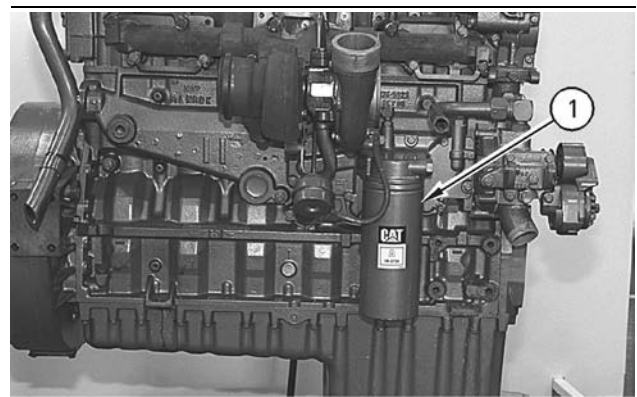

Illustration 87

g00614994

1. Remove oil filter assembly (1) with Tooling (A).

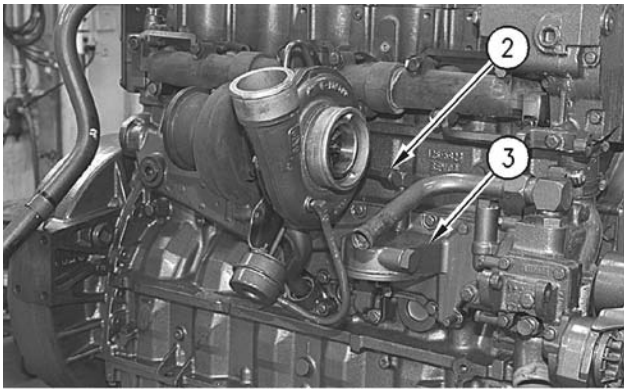

Illustration 88

g00614997

2. Disconnect tube (2) from the elbow assembly.
3. Remove the bolts that hold engine oil filter base (3) to the cylinder block. Remove engine oil filter base (3).

i01156967

Engine Oil Filter Base - Disassemble

SMCS Code: 1306-015

Disassembly Procedure

Start By:

- a. Remove the engine oil filter base. Refer to Disassembly and Assembly, "Engine Oil Filter Base - Remove".

NOTICE

Keep all parts clean from contaminants.

Contaminants may cause rapid wear and shortened component life.

NOTICE

Care must be taken to ensure that fluids are contained during performance of inspection, maintenance, testing, adjusting and repair of the product. Be prepared to collect the fluid with suitable containers before opening any compartment or disassembling any component containing fluids.

Refer to Special Publication, NENG2500, "Caterpillar Tools and Shop Products Guide" for tools and supplies suitable to collect and contain fluids on Caterpillar products.

Dispose of all fluids according to local regulations and mandates.

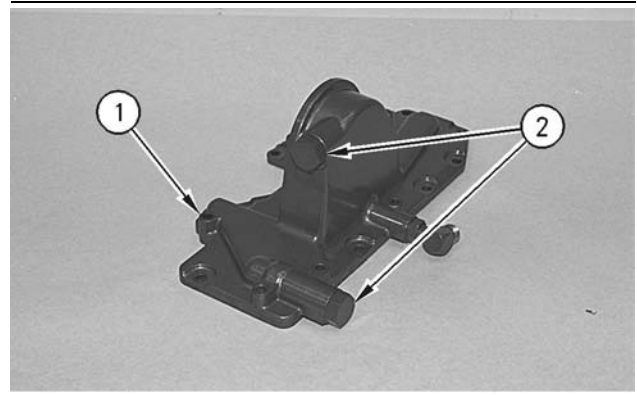

Illustration 89

g00615003

1. Remove plugs (2) from engine oil filter base (1).

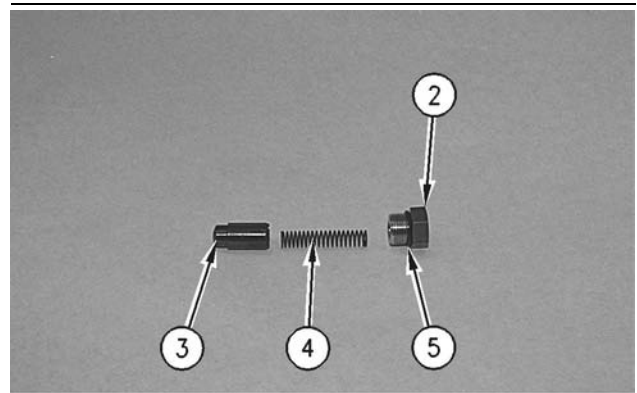

Illustration 90

g00615004

2. Remove valve springs (4) and valves (3) from engine oil filter base (1). Remove O-ring seals (5) from plugs (2).

i01156991

Engine Oil Filter Base - Assemble

SMCS Code: 1306-016

Assembly Procedure

NOTICE

Keep all parts clean from contaminants.

Contaminants may cause rapid wear and shortened component life.

1. Inspect the condition of the O-ring seals. Replace the O-ring seals, if necessary. The contact surfaces of the O-ring seals must be clean and dry.

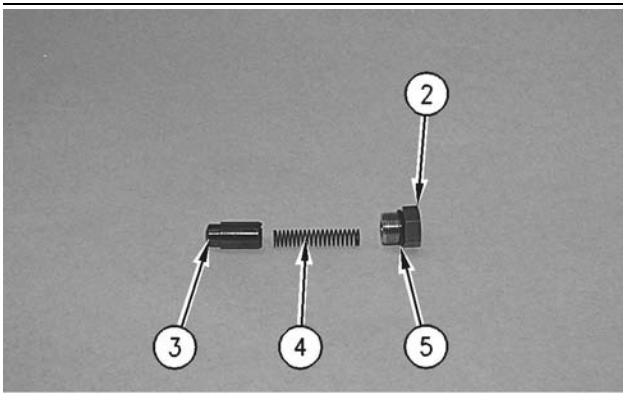

Illustration 91

g00615004

2. Install O-ring seals (5) on plugs (2). Apply clean engine oil on O-ring seals (5).

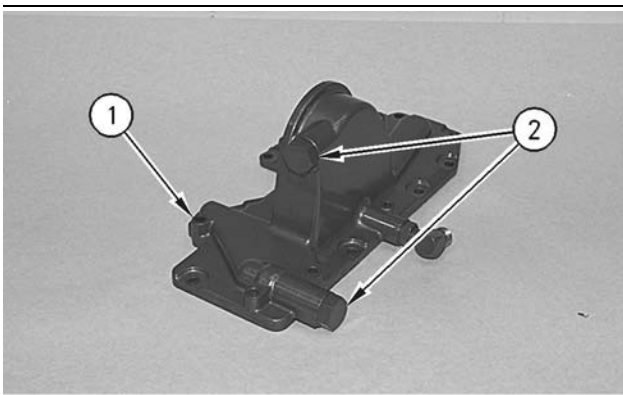

Illustration 92

g00615003

3. Apply clean engine oil on valves (3). Install valves (3), springs (4), and plugs (2) in engine oil filter base (1).

End By:

- a. Install the engine oil filter base. Refer to Disassembly and Assembly, "Engine Oil Filter Base - Install".

i01747122

Engine Oil Filter Base - Install

SMCS Code: 1306-012

Installation Procedure

Table 19

Required Tools			
Tool	Part Number	Part Description	Qty
A	185-3630	Strap Wrench Assembly	1

NOTICE

Keep all parts clean from contaminants.

Contaminants may cause rapid wear and shortened component life.

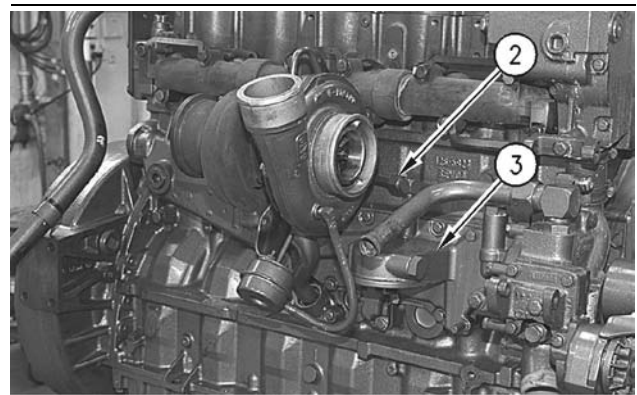

Illustration 93

g00614997

1. Position the gasket and engine oil filter base (3) over the engine oil cooler. Install the bolts that hold engine oil filter base (3) to the cylinder block.
2. Connect tube (2) to engine oil filter base (3).



Illustration 94

g00614994

3. Install oil filter assembly (1) with Tooling (A). Follow the instructions with the oil filter assembly for the correct installation.

i01747128

Engine Oil Pump - Remove

SMCS Code: 1304-011

Removal Procedure

Start By:

- a. Remove the engine oil pan. Refer to Disassembly and Assembly, "Engine Oil Pan - Remove and Install".

NOTICE

Keep all parts clean from contaminants.

Contaminants may cause rapid wear and shortened component life.

NOTICE

Care must be taken to ensure that fluids are contained during performance of inspection, maintenance, testing, adjusting and repair of the product. Be prepared to collect the fluid with suitable containers before opening any compartment or disassembling any component containing fluids.

Refer to Special Publication, NENG2500, "Caterpillar Tools and Shop Products Guide" for tools and supplies suitable to collect and contain fluids on Caterpillar products.

Dispose of all fluids according to local regulations and mandates.

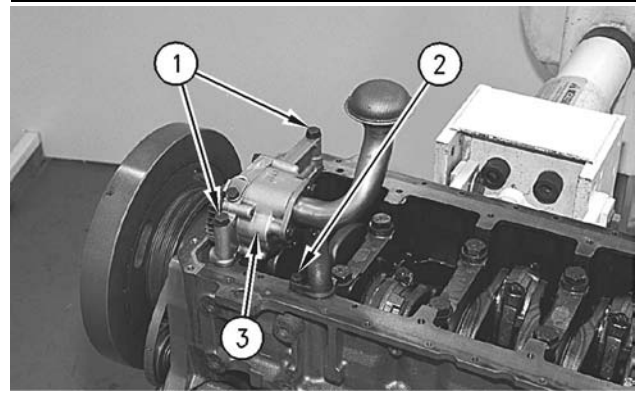

Illustration 95

g00894501

1. Remove bolt (1) and bolt (2).
2. Remove engine oil pump (3).
3. Remove the O-ring seal that is located between the cylinder block and the outlet elbow.

i01336717

Engine Oil Pump - Disassemble

SMCS Code: 1304-015

Disassembly Procedure

Table 20

Required Tools			
Tool	Part Number	Part Description	Qty
A	5P-7311	Chain Puller	1
	7S-7786	Puller Leg	2
	5F-7345	Screw	1

Start By:

- a. Remove the engine oil pump. Refer to Disassembly and Assembly, "Engine Oil Pump - Remove".

NOTICE

Keep all parts clean from contaminants.

Contaminants may cause rapid wear and shortened component life.

NOTICE

Care must be taken to ensure that fluids are contained during performance of inspection, maintenance, testing, adjusting and repair of the product. Be prepared to collect the fluid with suitable containers before opening any compartment or disassembling any component containing fluids.

Refer to Special Publication, NENG2500, "Caterpillar Tools and Shop Products Guide" for tools and supplies suitable to collect and contain fluids on Caterpillar products.

Dispose of all fluids according to local regulations and mandates.

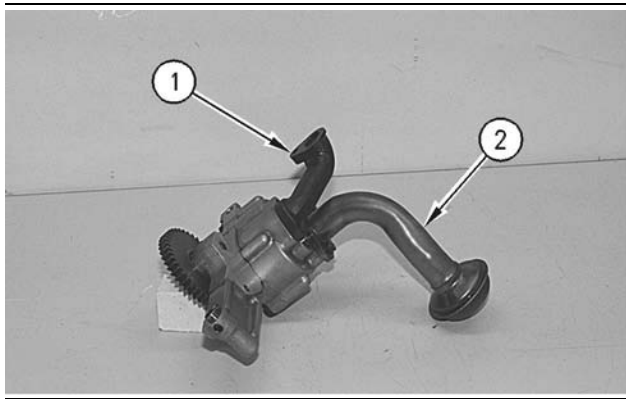

Illustration 96 g00614664

1. Remove the two bolts, oil pickup tube (2), and the gasket from the engine oil pump. Remove one bolt and outlet elbow (1) from the engine oil pump.

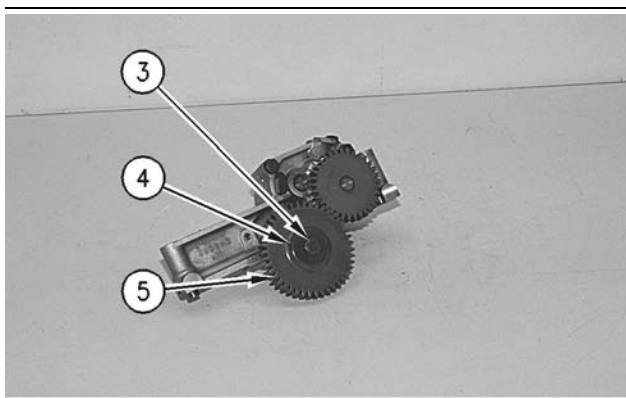

Illustration 97 g00614677

2. Remove bolt (3), washer (4), and idler gear (5) from the engine oil pump.

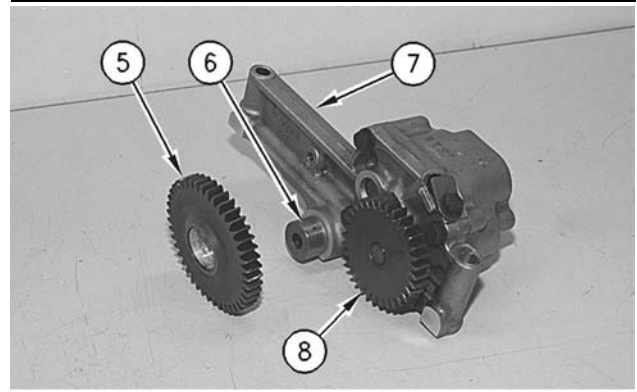

Illustration 98 g00614683

3. Remove the bearing from idler gear (5) with Tool (A).
4. Remove shaft (6) of engine oil pump from oil pump body assembly (7).
5. Use Tool (A) to remove drive gear (8).

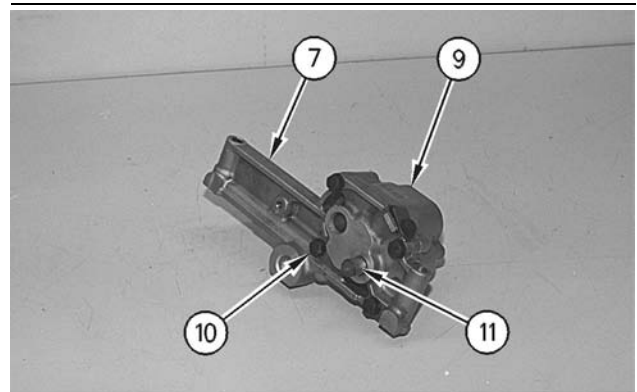

Illustration 99 g00614689

6. Remove four bolts (10). Separate oil pump body (9) from oil pump body assembly (7).

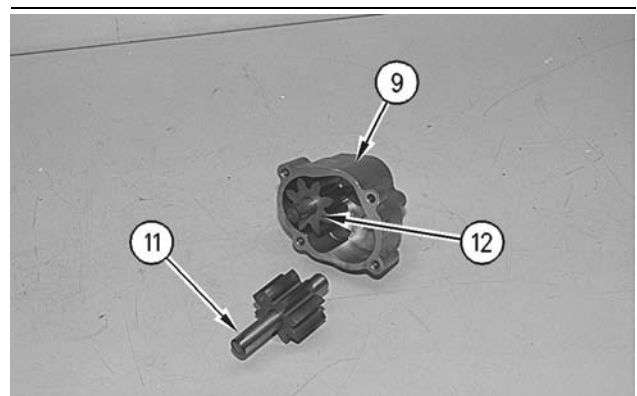

Illustration 100 g00614694

NOTICE

Before removing the drive shaft from the pump housing, be sure that no burrs exist on the drive shaft. If the drive shaft has burrs on it, the bores in the pump housing may be scratched.

- Remove shaft assembly (11) and shaft assembly (12) from oil pump body (9).

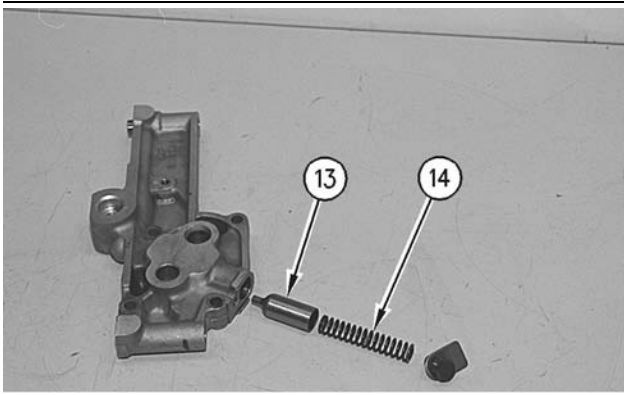

Illustration 101

g00614696

- Remove the following items from oil pump body assembly (7): bolt and washer, spring (14), and oil pressure relief valve (13)

i01336699

Engine Oil Pump - Assemble**SMCS Code:** 1304-016**Assembly Procedure****NOTICE**

Keep all parts clean from contaminants.

Contaminants may cause rapid wear and shortened component life.

- Ensure that all of the parts of the engine oil pump are thoroughly clean prior to assembly.

Note: Lubricate all internal parts of the engine oil pump with clean engine oil.

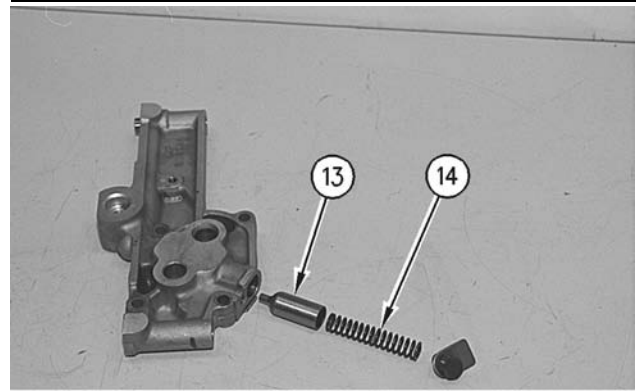

Illustration 102

g00614696

- Install oil pressure relief valve (13) and spring (14) in oil pump body (7). Install the washer and the bolt.

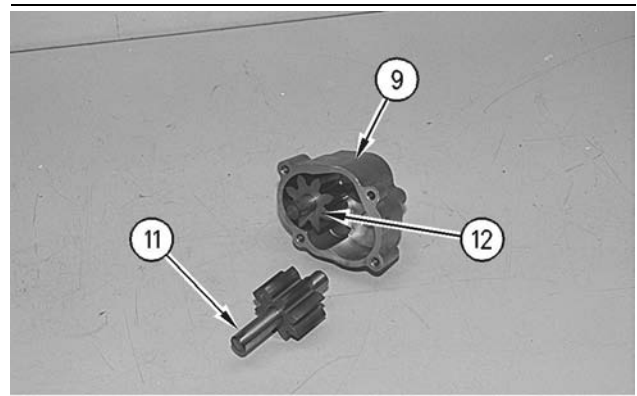

Illustration 103

g00614694

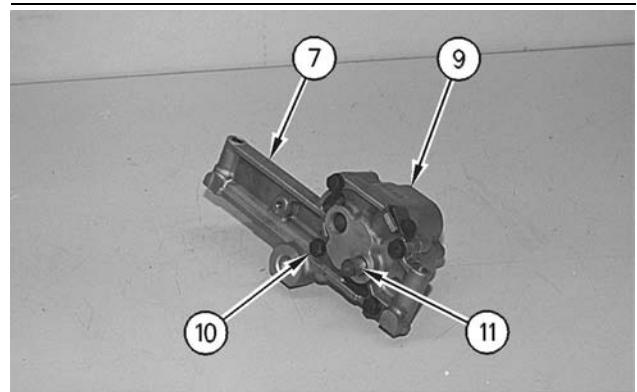

Illustration 104

g00614689

- Install shaft assembly (12) in oil pump body (9).
- Install shaft assembly (11) in oil pump body (9).
- Position oil pump body (9) on oil pump body assembly (7) and install bolts (10).

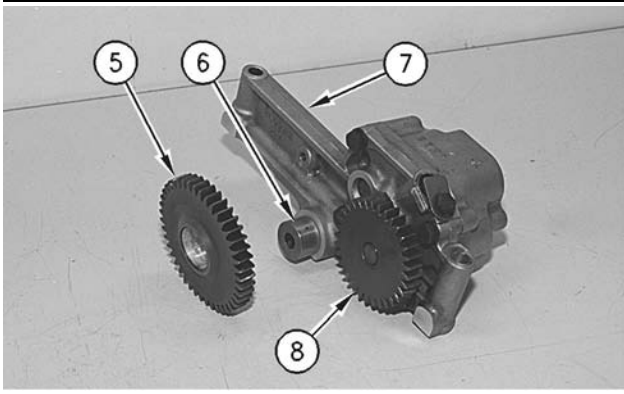

Illustration 105

g00614683

6. Press drive gear (8) on shaft assembly (11) until drive gear (8) is flush with the end of shaft assembly (11).
7. Install oil pump shaft (6). Install the bearing in idler gear (5). Install the bearing so the distance between the hub bolt face of idler gear (5) and the bearing is 0.75 ± 0.25 mm (0.030 ± 0.010 inch).

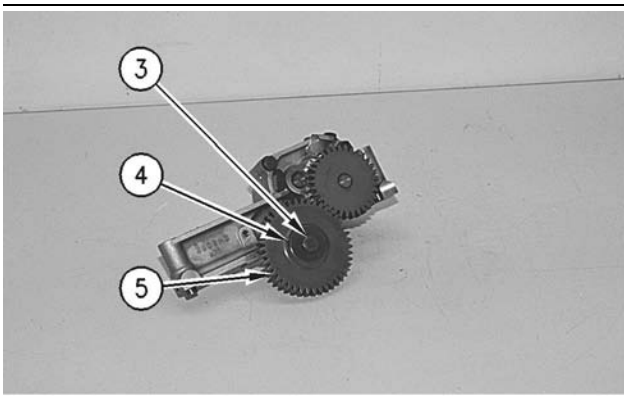

Illustration 106

g00614677

8. Install idler gear (5) on oil pump shaft (6). Install washer (4) and bolt (3). Tighten bolt (3) to 70 ± 15 N·m (52 ± 11 lb ft).

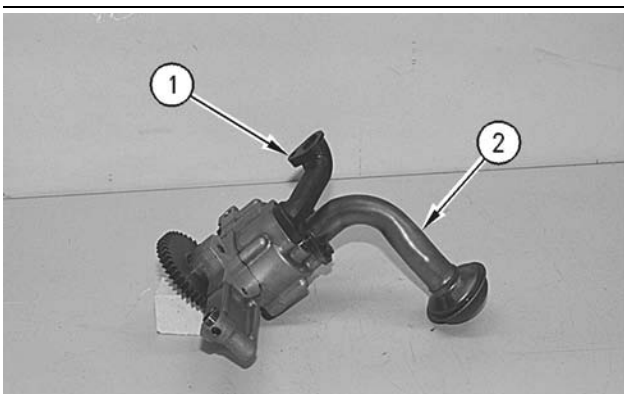

Illustration 107

g00614664

9. Check the condition of the gasket that is used in oil pickup tube (2). If the gasket is damaged, replace the gasket. Install the gasket and oil pickup tube (2).
10. Check the condition of the O-ring seal that is used in outlet elbow (1). If the O-ring seal is damaged, replace the O-ring seal. Install the O-ring seal and outlet elbow (1).

End By:

- a. Install the engine oil pump. Refer to Disassembly and Assembly, "Engine Oil Pump - Install".

i01747196

Engine Oil Pump - Install

SMCS Code: 1304-012

Installation Procedure

NOTICE

Keep all parts clean from contaminants.

Contaminants may cause rapid wear and shortened component life.

Note: Ensure that the mounting surfaces for the engine oil pump are thoroughly clean.

1. Inspect the condition of the O-ring seal. Replace the seal, if necessary.

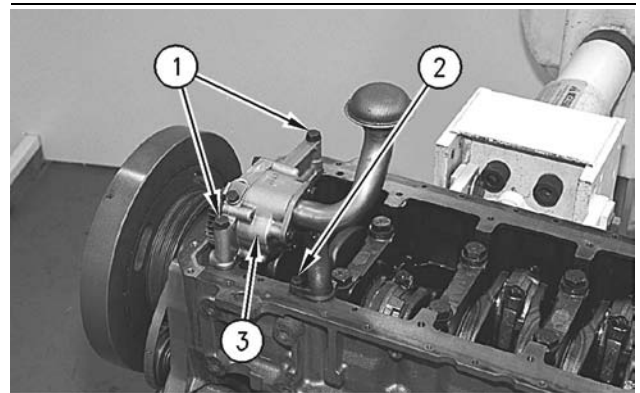

Illustration 108

g00894501

2. Install the O-ring seal. Position engine oil pump (3) on the cylinder block.

3. Install two bolts (1) and bolt (2).

End By:

- a. Install the engine oil pan. Refer to Disassembly and Assembly, "Engine Oil Pan - Remove and Install".

i01747228

Water Pump - Remove

SMCS Code: 1361-011

Removal Procedure

Start By:

- a. Remove the belt tensioner. Refer to Disassembly and Assembly, "Belt Tensioner - Remove and Install".

Note: Some engines may be equipped with a special mounting group for the fan. The mounting group may be one-piece or two-piece. It may be necessary to remove the mounting group for water pump maintenance. Refer to Disassembly and Assembly, "Fan Mounting Group - Remove and Install".

WARNING

Personal injury can result from hot coolant, steam and alkali.

At operating temperature, engine coolant is hot and under pressure. The radiator and all lines to heaters or the engine contain hot coolant or steam. Any contact can cause severe burns.

Remove cooling system pressure cap slowly to relieve pressure only when engine is stopped and cooling system pressure cap is cool enough to touch with your bare hand.

Do not attempt to tighten hose connections when the coolant is hot, the hose can come off causing burns.

Cooling System Coolant Additive contains alkali. Avoid contact with skin and eyes.

NOTICE

Keep all parts clean from contaminants.

Contaminants may cause rapid wear and shortened component life.

NOTICE

Care must be taken to ensure that fluids are contained during performance of inspection, maintenance, testing, adjusting and repair of the product. Be prepared to collect the fluid with suitable containers before opening any compartment or disassembling any component containing fluids.

Refer to Special Publication, NENG2500, "Caterpillar Tools and Shop Products Guide" for tools and supplies suitable to collect and contain fluids on Caterpillar products.

Dispose of all fluids according to local regulations and mandates.

1. Drain the coolant from the cooling system into a suitable container for storage or disposal.

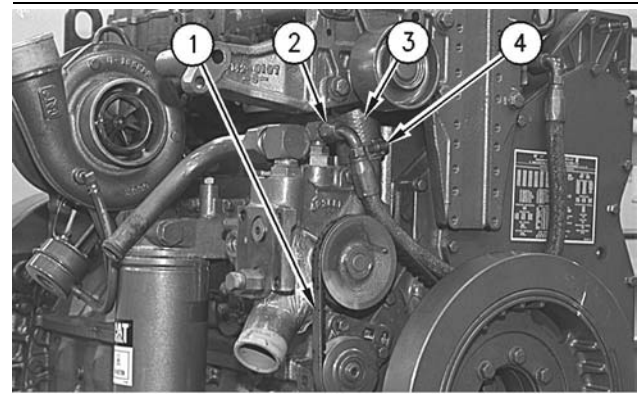

Illustration 109

g00614170

2. Remove water pump V-belt (1).
3. Loosen hose clamps (4) and remove hose (3).
4. Disconnect hose assembly (2) from the water pump elbow.

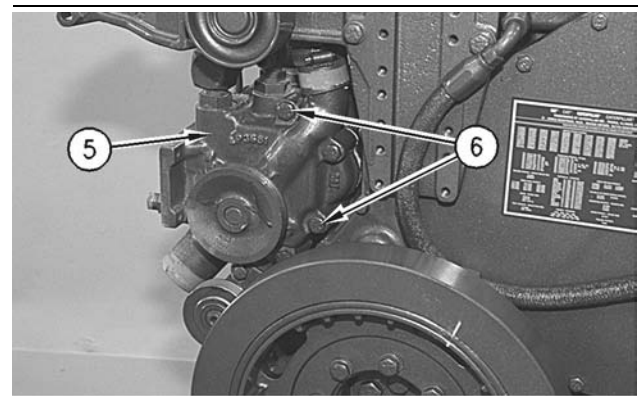

Illustration 110

g00614173

5. Remove four bolts (6) that hold water pump (5) to the front of the engine. Remove water pump (5).
6. Remove the O-ring seals from water pump (5), if necessary.

i01747241

Water Pump - Disassemble

SMCS Code: 1361-015

Disassembly Procedure

Table 21

Required Tools			
Tool	Part Number	Part Description	Qty
A	1P-0510	Driver Group	1
B	1P-0520	Driver Group	1

Start By:

- a. Remove the water pump. Refer to Disassembly and Assembly, "Water Pump - Remove".

NOTICE

Care must be taken to ensure that fluids are contained during performance of inspection, maintenance, testing, adjusting and repair of the product. Be prepared to collect the fluid with suitable containers before opening any compartment or disassembling any component containing fluids.

Refer to Special Publication, NENG2500, "Caterpillar Tools and Shop Products Guide" for tools and supplies suitable to collect and contain fluids on Caterpillar products.

Dispose of all fluids according to local regulations and mandates.

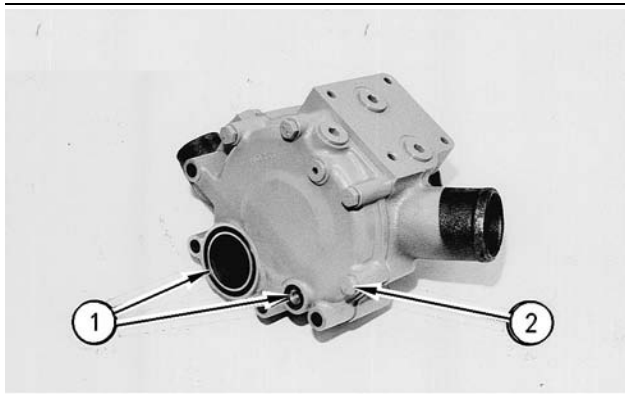

Illustration 111

g00614231

1. Remove two O-ring seals (1) from the rear cover of the water pump. Remove four bolts (2) and the washers. Remove the rear cover and the gasket.

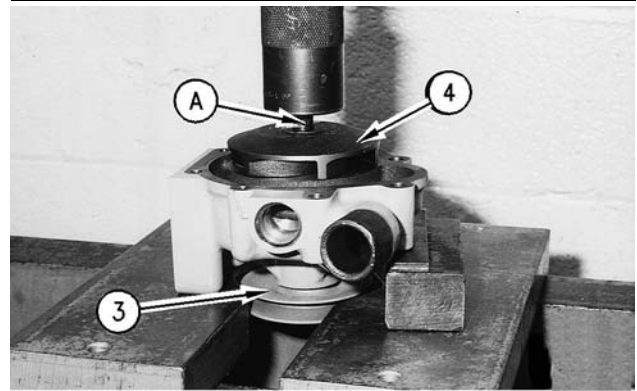

Illustration 112

g00614234

2. Position the water pump in a press. Use spacer plates to level the water pump.
3. Push the shaft and pulley (3) out of impeller (4) with a suitable drive plate from Tooling (A) and a press. Remove the impeller.

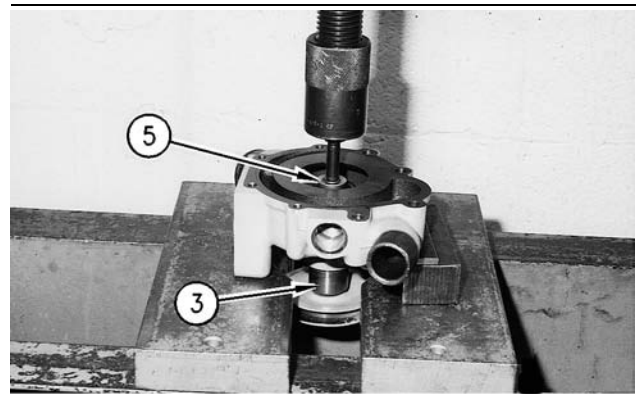

Illustration 113

g00614238

Note: Do not allow the shaft and the pulley to fall to the floor when the shaft and the pulley are removed.

4. Continue to push the shaft and pulley (3) out of seal (5) and the water pump housing.

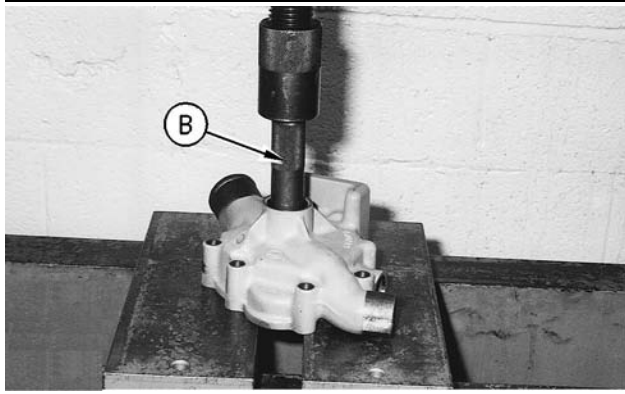

Illustration 114

g00614253

- Remove seal (5) from the water pump housing with the handle from Tooling (B) and a press.

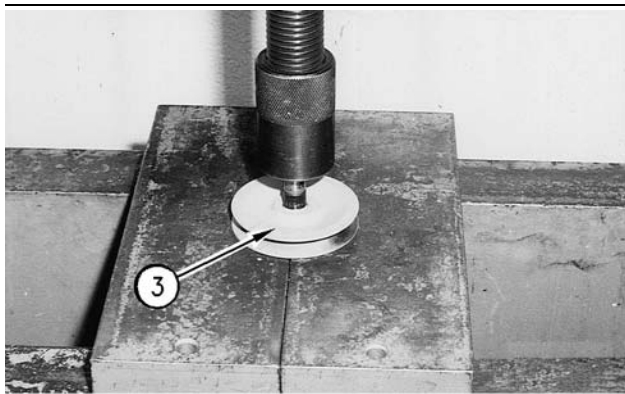

Illustration 115

g00614261

- Remove the shaft and the bearing from pulley (3) with a press.

i01275986

Water Pump - Assemble

SMCS Code: 1361-016

Assembly Procedure

Table 22

Required Tools			
Tool	Part Number	Part Description	Qty
A	5P-9722	Seal Driver	1

NOTICE

Keep all parts clean from contaminants.

Contaminants may cause rapid wear and shortened component life.

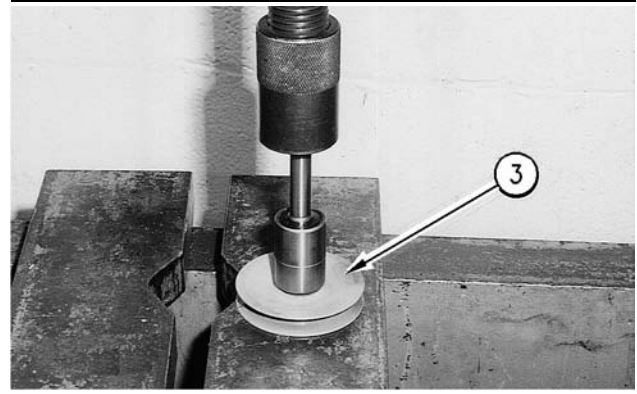

Illustration 116

g00614283

- Install the shaft and the bearing into pulley (3) with a press. Install the shaft until the shaft is flush with the end of pulley (3).
- Press the shaft, the bearing, and pulley (3) as a unit into the water pump housing. The distance between the front of pulley (3) and the machined surface of the water pump housing must be 103.8 ± 0.3 mm (4.09 ± 0.01 inch).

Note: For information on the reusability of pulley (3), refer to Guideline For Reusable Parts And Salvage Operations, SEBF8046, "Cast Iron and Steel Pulleys".

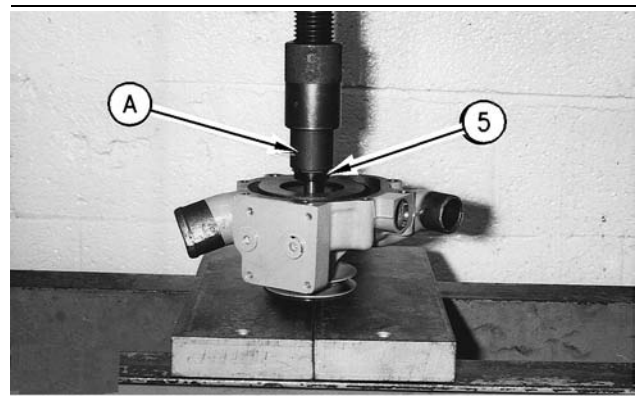

Illustration 117

g00614294

- Install seal (5) in the water pump housing with Tool (A).

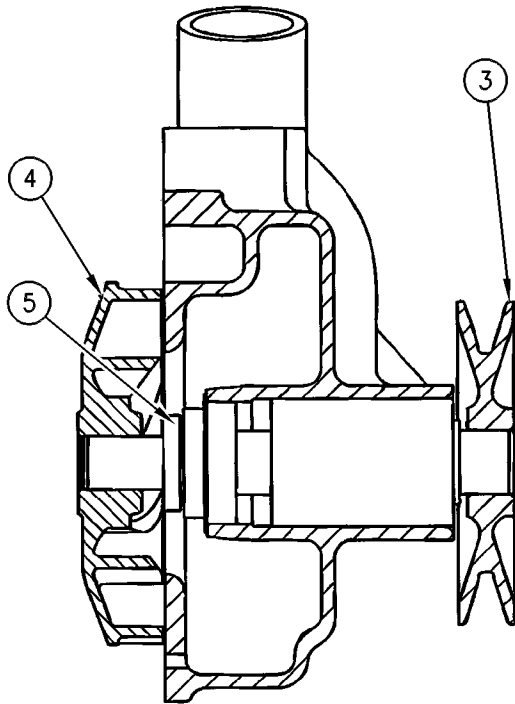

Illustration 118

g00614288

4. Install impeller (4) on the shaft of the water pump with a press. Install the impeller until the distance between the impeller and the machined surface of the water pump is 0.75 ± 0.25 mm (0.030 ± 0.010 inch).

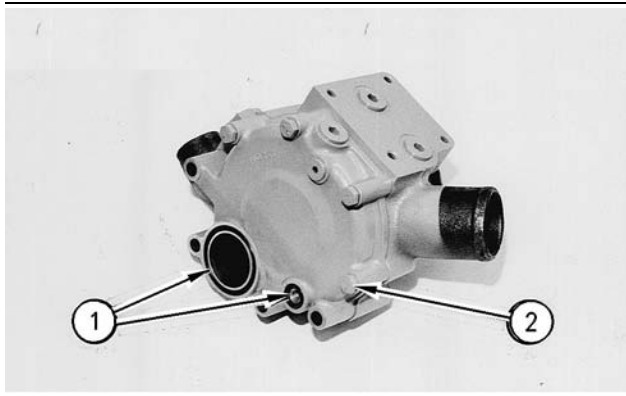

Illustration 119

g00614231

5. Install a new gasket between the rear cover of the water pump and the water pump housing. Position the gasket and the cover on the water pump housing. Install four bolts (2) and the washers.
6. Install two new O-ring seals (1) in the rear cover.

End By:

- a. Install the water pump. Refer to Disassembly and Assembly, "Water Pump - Install".

i01747251

Water Pump - Install

SMCS Code: 1361-012

Installation Procedure

NOTICE

Keep all parts clean from contaminants.

Contaminants may cause rapid wear and shortened component life.

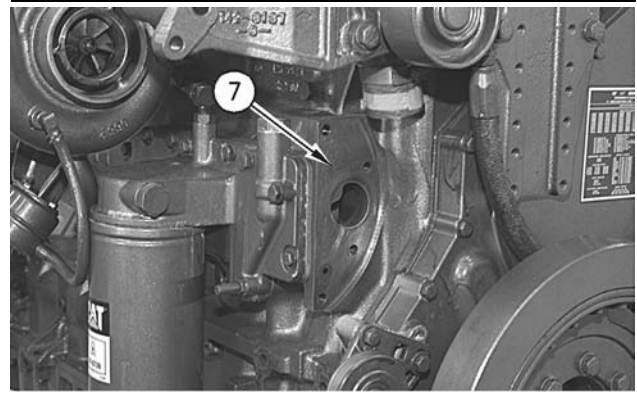

Illustration 120

g00614182

1. Clean surface (7).
2. Inspect the condition of the O-ring seals. Replace the seals, if necessary.

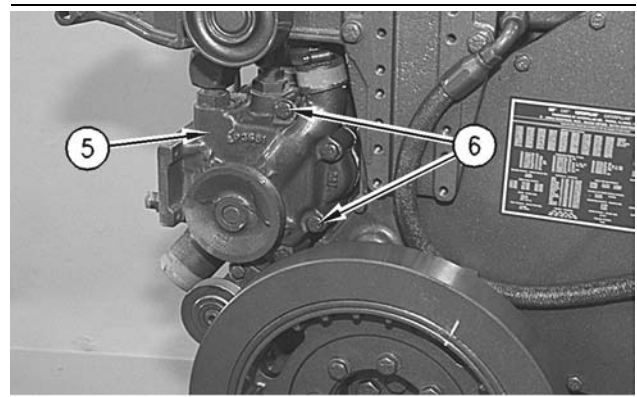

Illustration 121

g00614173

3. Install the O-ring seal on water pump (5).
4. Position water pump (5) on the front of the engine. Install four bolts (6).

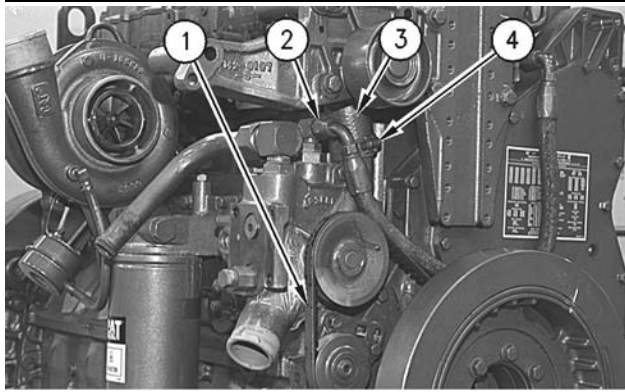

Illustration 122

g00614170

5. Connect hose (3) to water pump (5) and to the water temperature regulator housing. Install two clamps (4).
6. Install hose assembly (2) to the water pump elbow.
7. Install V-belt (1) and adjust V-belt (1). Refer to the Specifications Module, "Belt Tension Chart".
8. Fill the cooling system with coolant to the correct level. Refer to the Operation and Maintenance Manual for the correct filling procedure.

End By:

- a. If equipped, install the special fan drive mounting. The mounting may be one-piece or two-piece. Refer to Disassembly and Assembly, "Fan Drive Mounting Group - Remove and Install".
- b. Install the belt tensioner. Refer to Disassembly and Assembly, "Belt Tensioner - Remove and Install".

Water Temperature Regulator - Remove and Install

SMCS Code: 1355-010

Removal Procedure

⚠ WARNING

Personal injury can result from hot coolant, steam and alkali.

At operating temperature, engine coolant is hot and under pressure. The radiator and all lines to heaters or the engine contain hot coolant or steam. Any contact can cause severe burns.

Remove cooling system pressure cap slowly to relieve pressure only when engine is stopped and cooling system pressure cap is cool enough to touch with your bare hand.

Do not attempt to tighten hose connections when the coolant is hot, the hose can come off causing burns.

Cooling System Coolant Additive contains alkali. Avoid contact with skin and eyes.

NOTICE

Keep all parts clean from contaminants.

Contaminants may cause rapid wear and shortened component life.

NOTICE

Care must be taken to ensure that fluids are contained during performance of inspection, maintenance, testing, adjusting and repair of the product. Be prepared to collect the fluid with suitable containers before opening any compartment or disassembling any component containing fluids.

Refer to Special Publication, NENG2500, "Caterpillar Tools and Shop Products Guide" for tools and supplies suitable to collect and contain fluids on Caterpillar products.

Dispose of all fluids according to local regulations and mandates.

1. Drain the coolant from the cooling system into a suitable container for storage or disposal.

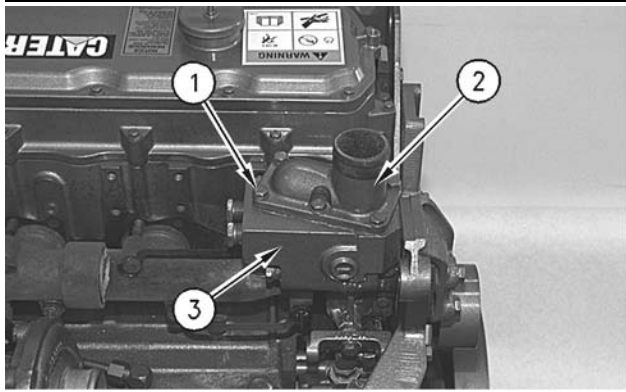

Illustration 123

g00613949

2. Remove bolts (1) and pipe (2) from water temperature regulator housing (3).

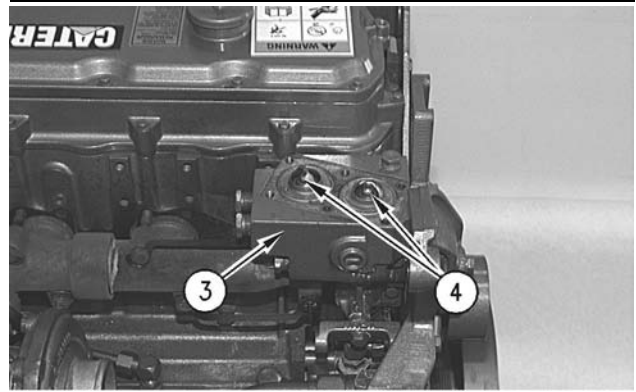

Illustration 125

g00613961

1. Place water temperature regulators (4) in water temperature regulator housing (3).

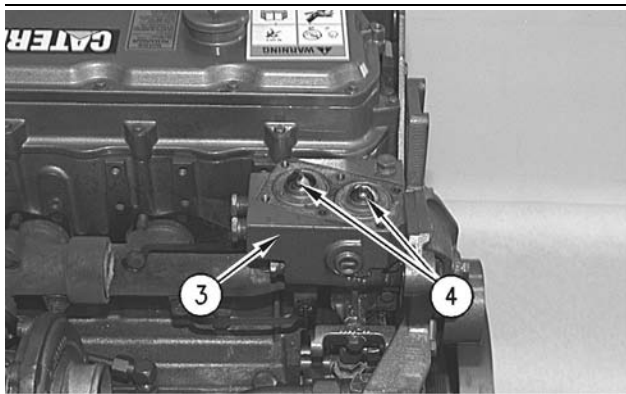

Illustration 124

g00613961

3. Remove water temperature regulators (4) from water temperature regulator housing (3). Remove the gasket from water temperature regulator housing (3).

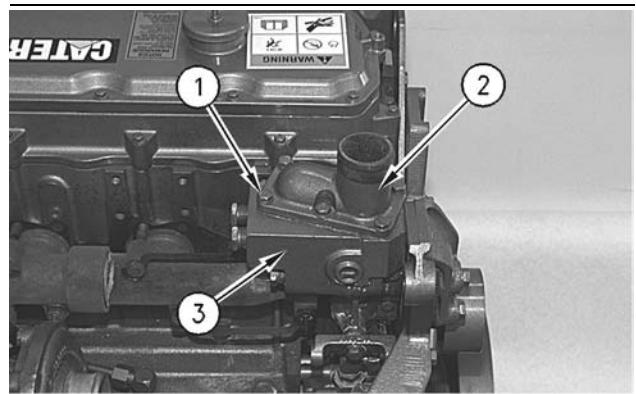

Illustration 126

g00613949

2. Install a new gasket and pipe (2) in water temperature regulator housing (3).
3. Install bolts (1).
4. Fill the cooling system with coolant to the correct level. Refer to the Operation and Maintenance Manual for the correct filling procedure.

Installation Procedure

NOTICE

Keep all parts clean from contaminants.

Contaminants may cause rapid wear and shortened component life.

i01747259

Flywheel - Remove

SMCS Code: 1156-011

Removal Procedure

Table 23

Required Tools			
Tool	Part Number	Part Description	Qty
A	138-7573	Link Bracket	2

1. Support the engine with blocks or a suitable lifting device.

2. Install Tooling (A) on the flywheel. Fasten a suitable lifting device to the flywheel.

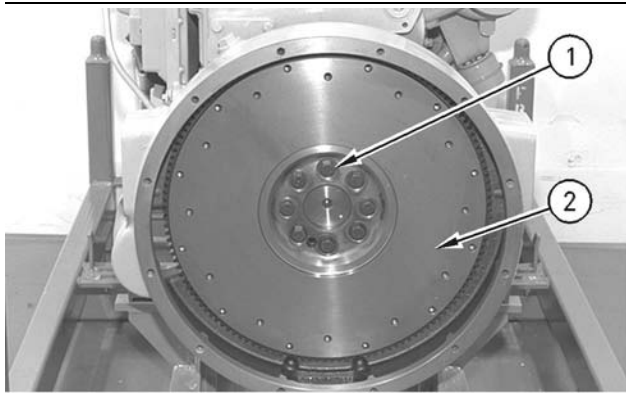

Illustration 127

g00613482

3. Remove top bolt (1) and the washers. Install a guide bolt that is longer than top bolt (1). Remove seven remaining bolts (1) and the washers.
4. Remove flywheel (2) from the guide bolt. The weight of flywheel (2) is approximately 23 kg (50 lb).
5. Inspect the flywheel ring gear. Replace the ring gear, if necessary. Place the flywheel on a wood block. Use a hammer and a punch in order to remove the flywheel ring gear.

i01747268

Flywheel - Install

SMCS Code: 1156-012

Installation Procedure

Table 24

Required Tools			
Tool	Part Number	Part Description	Qty
A	138-7573	Link Bracket	2

Note: Drill and tap the new flywheel ring gear if the outer bolt holes of the flywheel are used. Use the flywheel as a template and drill twelve holes to a diameter of 8.2 mm (0.32 inch). Thread the holes with a tap.

1. Heat the flywheel ring gear to a maximum temperature of 204 °C (400 °F). Do not use a torch to heat the flywheel ring gear. Install the flywheel ring gear on the flywheel. Position the flywheel ring gear with the part number toward the crankshaft. Allow the flywheel ring gear to cool. Use a soft hammer in order to seat the flywheel ring gear against the shoulder of the flywheel.

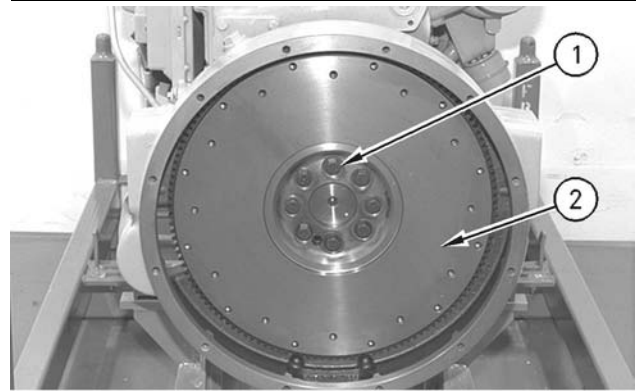

Illustration 128

g00613482

2. Install Tooling (A) on flywheel (2). Fasten a suitable lifting device to flywheel (2).
3. Place flywheel (2) in the original position on the guide bolt. Align the arrows on flywheel (2) and the crankshaft.
4. Apply 9S-3263 Thread Lock Compound to the threads of eight bolts (1).
5. Install seven bolts (1) and the washers. Remove the guide bolt and install remaining bolt (1) and the washer. Tighten the bolts evenly to a torque of 120 ± 20 N·m (90 ± 15 lb ft).
6. Check the flywheel runout. Refer to Testing and Adjusting, "Flywheel - Inspect" for the correct procedure.

i01747284

Crankshaft Rear Seal - Remove

SMCS Code: 1161-011

Removal Procedure

Table 25

Required Tools			
Tool	Part Number	Part Description	Qty
A	1U-8145	Drill Bit	1
B	1U-7600	Slide Hammer Puller	1

Start By:

- a. Remove the flywheel. Refer to Disassembly and Assembly, "Flywheel - Remove".

NOTICE

Keep all parts clean from contaminants.

Contaminants may cause rapid wear and shortened component life.

NOTICE

Care must be taken to ensure that fluids are contained during performance of inspection, maintenance, testing, adjusting and repair of the product. Be prepared to collect the fluid with suitable containers before opening any compartment or disassembling any component containing fluids.

Refer to Special Publication, NENG2500, "Caterpillar Tools and Shop Products Guide" for tools and supplies suitable to collect and contain fluids on Caterpillar products.

Dispose of all fluids according to local regulations and mandates.

1. Use Tooling (A) to drill three evenly spaced holes in the crankshaft rear seal.

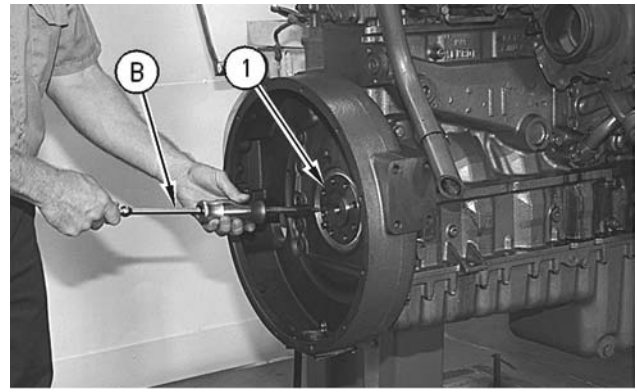

Illustration 129

g00613243

Note: Do not damage the flange on the crankshaft when the crankshaft rear seal is removed.

Note: Tooling (B) is equipped with three screw tips. Use the screw tips with Tooling (B) to remove crankshaft rear seal (1).

2. Carefully remove crankshaft rear seal (1) by alternating the position of Tooling (B) from hole to hole. This will allow crankshaft rear seal (1) to be removed evenly without damage to the rear flange surface of the crankshaft.

Note: New engines from the factory do not have a wear sleeve. Engines with seals that have been replaced will be equipped with a wear sleeve. If the crankshaft of the engine is equipped with a wear sleeve, refer to Disassembly and Assembly, "Crankshaft Wear Sleeve (Rear) - Remove" in order to remove the wear sleeve.

i01747293

Crankshaft Rear Seal - Install

SMCS Code: 1161-012

Installation Procedure

Table 26

Required Tools			
Tool	Part Number	Part Description	Qty
A ⁽¹⁾	132-8772	Seal Locator	1
B ⁽¹⁾	1U-7596	Bolt	2
C ⁽¹⁾	1U-7597	Sleeve Ring	1
D ⁽¹⁾	1U-7594	Seal Installer	1
E ⁽¹⁾	9S-8858	Nut	1

⁽¹⁾ Part of the 1U-7598 Seal Installer

NOTICE

Keep all parts clean from contaminants.

Contaminants may cause rapid wear and shortened component life.

Note: Replacement rear seals are supplied with a wear sleeve. This wear sleeve must be installed with the rear seal. New engines from the factory do not have a wear sleeve. Do not install the rear seal if any of the following conditions exist:

- The crankshaft rear seal has been separated from the wear sleeve.
 - The rear seal group appears to be damaged.
 - The crankshaft rear seal has been lubricated. The seal is designed to be installed dry.
1. Ensure that the rear of the crankshaft is thoroughly clean and dry prior to the installation of the crankshaft rear seal.

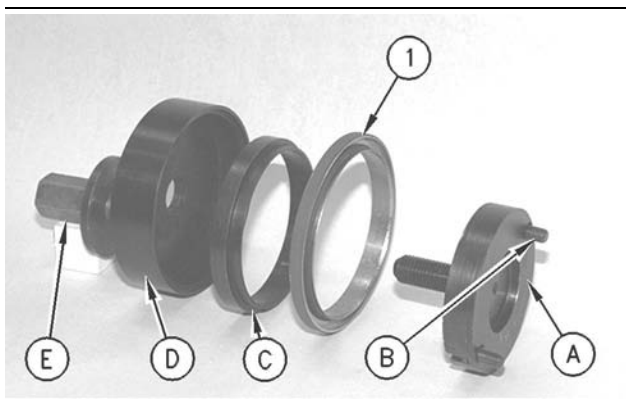

Illustration 130

g00613561

2. Fasten Tooling (A) to the rear of the crankshaft with Tooling (B). Hand tighten Tooling (B).
3. Position the crankshaft rear seal and crankshaft rear sleeve (1) on Tooling (A). Position Tooling (C) on Tooling (A).

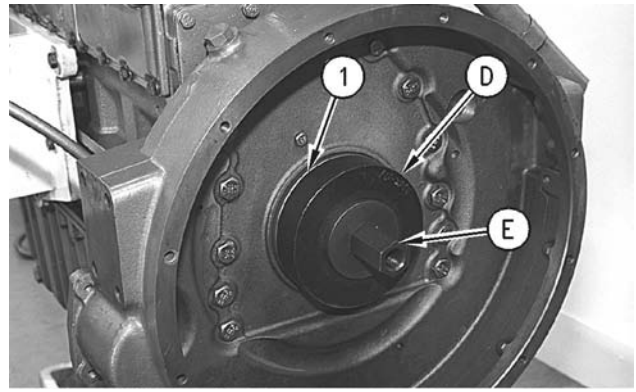

Illustration 131

g00614109

Typical example

4. Position Tooling (D) over Tooling (A) and Tooling (C). Install Tooling (E). Tighten Tooling (E) in order to install the crankshaft rear seal and the crankshaft wear sleeve.
5. Remove Tooling (E), Tooling (D), and Tooling (C). Turn over Tooling (C). Install Tooling (C), Tooling (D), and Tooling (E). Tighten Tooling (E) in order to complete the installation of the crankshaft rear seal and the crankshaft wear sleeve.
6. Remove Tooling (E) and Tooling (D). Check Tooling (C) and Tooling (A). The faces of Tooling (C) and Tooling (A) will be flush if the crankshaft rear seal and the crankshaft wear sleeve are properly installed. Refer to the Specifications module for more information.
7. Remove Tooling (C), Tool (B), and Tooling (A).

End By:

- a. Install the flywheel. Refer to Disassembly and Assembly, "Flywheel - Install".

i01747309

Crankshaft Wear Sleeve (Rear) - Remove (If Equipped)

SMCS Code: 1161-011-ZV

Removal Procedure

Table 27

Required Tools			
Tool	Part Number	Part Description	Qty
A	4C-4869	Distorter Ring	1
B	5P-7312	Seal Distorter	1

Start By:

- a. Remove the crankshaft rear seal. Refer to Disassembly and Assembly, "Crankshaft Rear Seal - Remove".

NOTICE

Keep all parts clean from contaminants.

Contaminants may cause rapid wear and shortened component life.

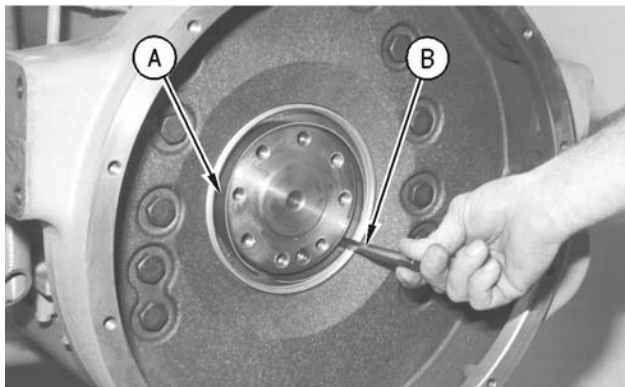

Illustration 132

g00614029

Note: Wear sleeves are not installed at the factory. The wear sleeve is included with the replacement rear seal.

1. Install Tooling (A) in the bore of the crankshaft rear sleeve.
2. Install Tooling (B) between Tooling (A) and the crankshaft wear sleeve. Turn Tooling (B) until the edge of Tooling (B) makes a crease in the crankshaft wear sleeve. Make a crease in the crankshaft wear sleeve at two other locations around the crankshaft wear sleeve until the crankshaft wear sleeve is loose.

3. Remove Tooling (B), Tooling (A), and the crankshaft wear sleeve from the end of the crankshaft.

i01747314

Crankshaft Wear Sleeve (Rear) - Install

SMCS Code: 1161-012-ZV

Installation Procedure

Table 28

Required Tools			
Tool	Part Number	Part Description	Qty
A ⁽¹⁾	132-8772	Seal Locator	1
B ⁽¹⁾	1U-7596	Bolt	2
C ⁽¹⁾	1U-7597	Sleeve Ring	1
D ⁽¹⁾	1U-7594	Seal Installer	1
E ⁽¹⁾	9S-8858	Nut	1

(1) Part of the 1U-7598 Seal Installer

NOTICE

Keep all parts clean from contaminants.

Contaminants may cause rapid wear and shortened component life.

1. Ensure that the rear of the crankshaft is thoroughly clean and dry prior to the installation of the crankshaft rear seal.

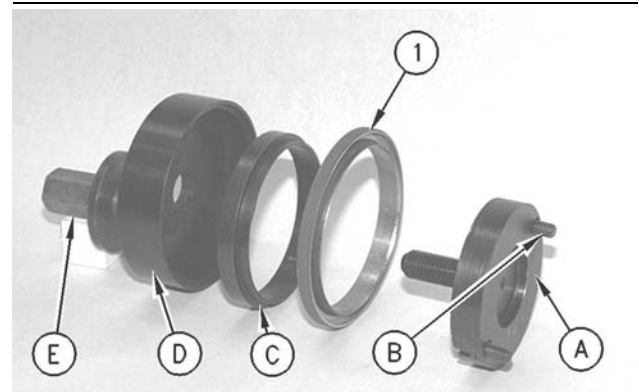

Illustration 133

g00613561

2. Fasten Tooling (A) to the rear of the crankshaft with Tooling (B). Hand tighten Tooling (B).
3. Position the crankshaft rear seal and crankshaft rear sleeve (1) on Tooling (A). Position Tooling (C) on Tooling (A).

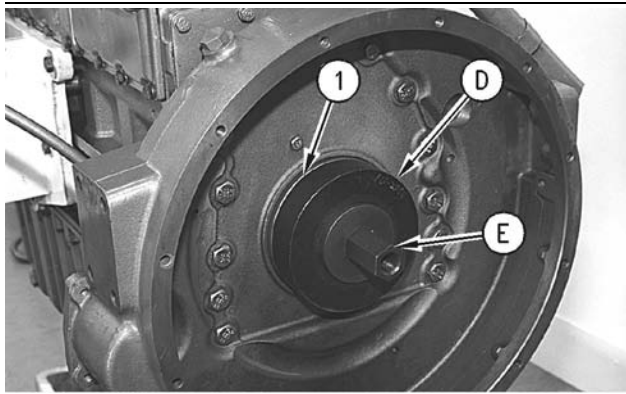

Illustration 134

g00614109

4. Position Tooling (D) over Tooling (A) and Tooling (C). Install Tooling (E). Tighten Tooling (E) in order to install the crankshaft rear seal and the crankshaft wear sleeve.
5. Remove Tooling (E), Tooling (D), and Tooling (C). Turn over Tooling (C). Install Tooling (C), Tooling (D), and Tooling (E). Tighten Tooling (E) in order to complete the installation of the crankshaft rear seal and the crankshaft wear sleeve.
6. Remove Tooling (E) and Tooling (D). Check Tooling (C) and Tooling (A). The faces of Tooling (C) and Tooling (A) will be flush if the crankshaft rear seal and the crankshaft wear sleeve are properly installed. Refer to the Specifications Module for more information.
7. Remove Tooling (C), Tooling (B), and Tooling (A).

End By:

- a. Install the flywheel. Refer to Disassembly and Assembly, "Flywheel - Install".

i01579321

Crankshaft Rear Seal Carrier - Remove and Install

SMCS Code: 1161-010-C3

Removal Procedure

Start By:

- a. Remove the flywheel housing. Refer to Disassembly and Assembly, "Flywheel Housing - Remove and Install".

NOTICE

Keep all parts clean from contaminants.

Contaminants may cause rapid wear and shortened component life.

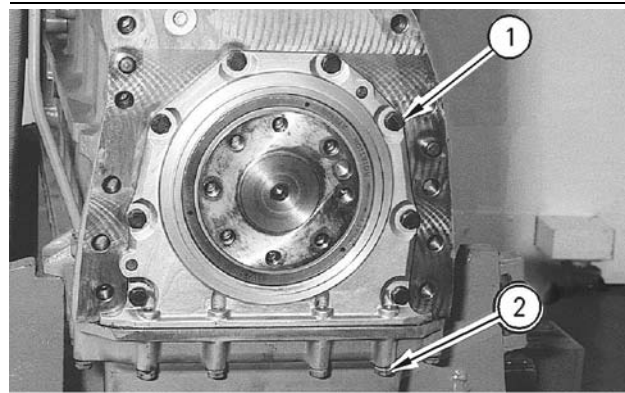

Illustration 135

g00613081

1. Remove bolts (2) for the engine oil pan and carefully lower the engine oil pan away from the cylinder block.
2. Remove eight bolts (1) and the washers that hold the rear seal carrier for the crankshaft to the cylinder block.
3. Carefully pry the rear seal carrier for the crankshaft off of the two dowels in the cylinder block.

Installation Procedure

NOTICE

Keep all parts clean from contaminants.

Contaminants may cause rapid wear and shortened component life.

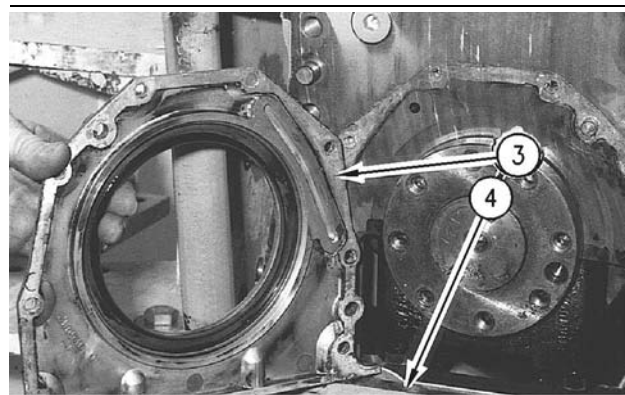

Illustration 136

g00613107

i01747475

1. Clean the joint face of rear seal carrier for the crankshaft (3) and cylinder block (4) with 138-8440 Component Cleaner.
2. Apply 169-5464 Quick Cure Primer to the joint face of rear seal carrier for the crankshaft (3). Allow the primer to air dry for three to five minutes.

Note: 1U-8846 Sealant is used on the joint face of the rear seal carrier for the crankshaft. Do not allow the sealant to get into the oil passage in the mounting face of the cylinder block.

3. Apply 1U-8846 Sealant to the joint face of rear seal carrier for the crankshaft (3). Spread the sealant uniformly. The rear seal carrier for the crankshaft (3) must be installed within ten minutes of application of the sealant.
4. Position the rear seal carrier for the crankshaft (3) on the dowels in the rear of the cylinder block. Use a soft faced hammer to position the rear seal carrier for the crankshaft (3) against the cylinder block, if necessary.

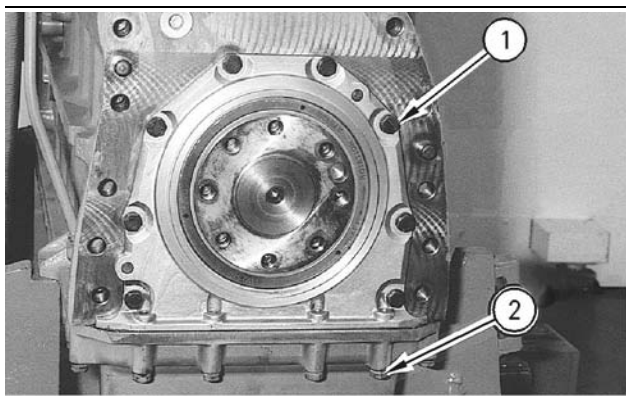

Illustration 137

g00613081

5. Apply 9S-3263 Thread Lock Compound on the threads of eight bolts (1). Install eight bolts (1) that hold the rear seal carrier for the crankshaft (3) to the cylinder block.
6. Install a new gasket on the engine oil pan. Install the engine oil pan on the cylinder block. Install bolts (2).

End By:

- a. Install the flywheel housing. Refer to Disassembly and Assembly, "Flywheel Housing - Remove and Install".

Flywheel Housing - Remove and Install

SMCS Code: 1157-010

Removal Procedure

Table 29

Required Tools			
Tool	Part Number	Part Description	Qty
A	138-7573	Link Bracket	2

Start By:

- a. Remove the flywheel. Refer to Disassembly and Assembly, "Flywheel - Remove".

NOTICE

Keep all parts clean from contaminants.

Contaminants may cause rapid wear and shortened component life.

NOTICE

Care must be taken to ensure that fluids are contained during performance of inspection, maintenance, testing, adjusting and repair of the product. Be prepared to collect the fluid with suitable containers before opening any compartment or disassembling any component containing fluids.

Refer to Special Publication, NENG2500, "Caterpillar Tools and Shop Products Guide" for tools and supplies suitable to collect and contain fluids on Caterpillar products.

Dispose of all fluids according to local regulations and mandates.

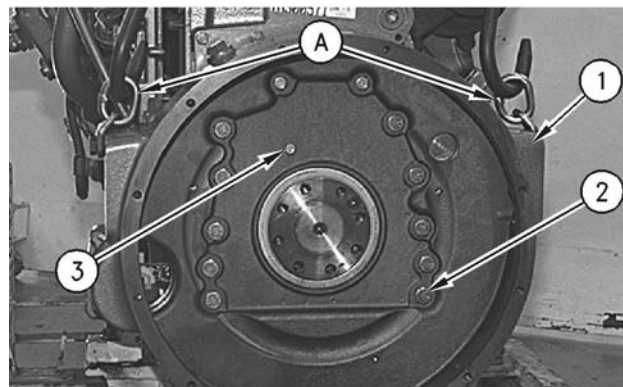

Illustration 138

g00650171

1. Fasten Tooling (A) and a hoist to flywheel housing (1).
2. Remove twelve bolts (2) and bolt (3) that fastens the flywheel housing to the cylinder block.

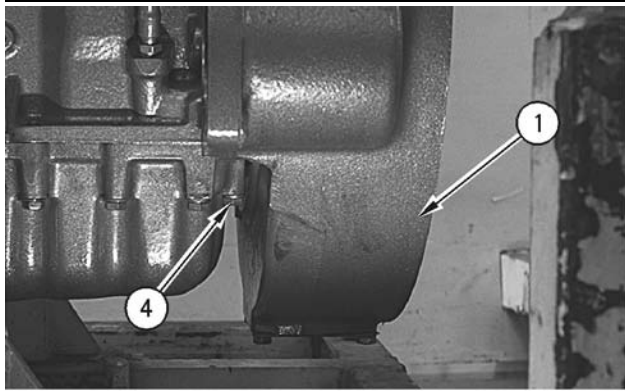

Illustration 139

g00612738

3. Remove four bolts (4) that fasten the engine oil pan to flywheel housing (1). Remove flywheel housing (1). The weight of flywheel housing (1) is approximately 25 kg (55 lb).

Installation Procedure

Table 30

Required Tools			
Tool	Part Number	Part Description	Qty
A	138-7573	Link Bracket	2

NOTICE

Keep all parts clean from contaminants.

Contaminants may cause rapid wear and shortened component life.

Note: Ensure that the mating surface of the flywheel housing and the mounting face of the cylinder block are thoroughly clean. Inspect the gasket of the engine oil pan for damage. Replace the gasket, if necessary.

1. Apply 1U-8846 Sealant to the entire mounting face of the flywheel housing prior to installation.

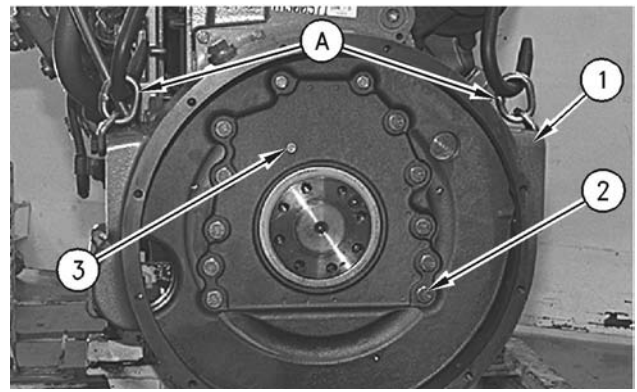

Illustration 140

g00650171

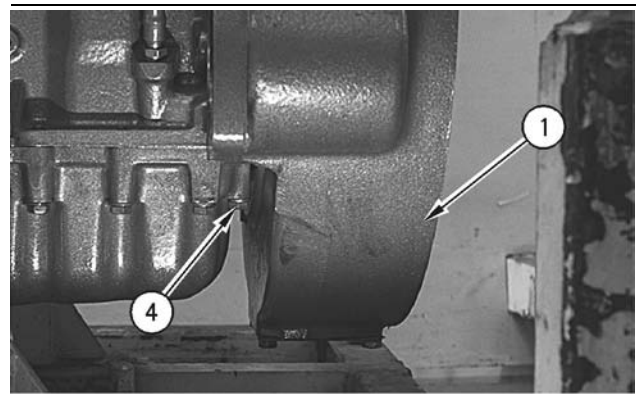

Illustration 141

g00612738

2. Fasten Tooling (A) and a hoist to flywheel housing (1). Position flywheel housing (1) on the cylinder block. The weight of flywheel housing (1) is approximately 25 kg (55 lb). Install four bolts (4) that fasten the engine oil pan to flywheel housing (1).
3. Install twelve bolts (2) and one bolt (3) that fastens the flywheel housing to the cylinder block.
4. Remove Tooling (A) and the hoist from flywheel housing (1).
5. Check the flywheel housing runout. Refer to the Systems Operation/Testing and Adjusting, "Flywheel and Flywheel Housing".

End By:

- a. Install the flywheel. Refer to Disassembly and Assembly, "Flywheel - Install".

i01747486

Rear Power Take-Off (RPTO) - Disassemble

SMCS Code: 1165-011-RE

Removal Procedure

Table 31

Required Tools			
Tool	Part Number	Part Description	Qty
A	6V-8004 ⁽¹⁾	Guide Bolt	2
B	1P-0520	Driver Group	1
C	1P-0510	Driver Group	1
D	156-7100	Puller Group	1

⁽¹⁾ Cut off the head of 6V-8004 Bolt and chamfer edges.

Start By:

- a. Remove the flywheel. Refer to Disassembly and Assembly, "Flywheel - Remove".

NOTICE

Keep all parts clean from contaminants.

Contaminants may cause rapid wear and shortened component life.

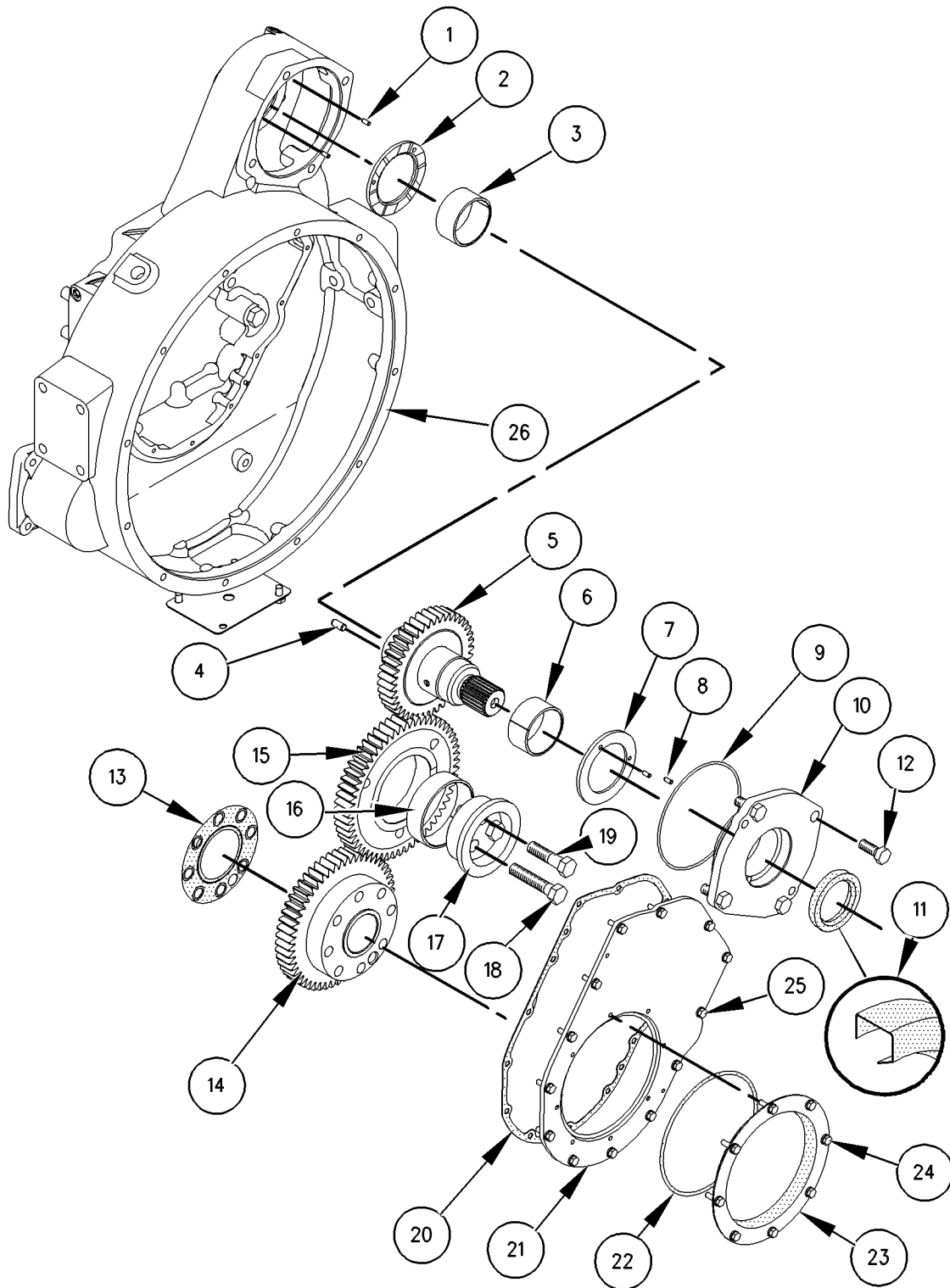

Illustration 142

- (1) Dowel
- (2) Thrust Washer
- (3) Sleeve Bearing
- (4) Dowel
- (5) Gear Assembly
- (6) Sleeve Bearing
- (7) Thrust Washer
- (8) Dowel
- (9) Seal

- (10) Adapter Assembly
- (11) Lip Seal
- (12) Bolt
- (13) Seal
- (14) Gear Assembly
- (15) Gear Assembly
- (16) Sleeve Bearing
- (17) Shaft
- (18) Bolt

- (19) Bolt
- (20) Gasket
- (21) Cover
- (22) Seal
- (23) Cover
- (24) Bolt
- (25) Bolt
- (26) Housing for Rear Power Take-Off

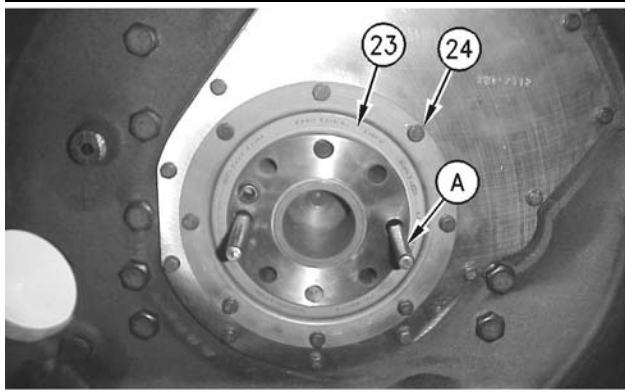

Illustration 143

g00759600

1. Install Tooling (A) in the crankshaft.
2. Remove bolts (24), washers, crankshaft rear seal (23) and O-ring seal (22). Refer to Illustration 142.
3. Remove bolts (25), washers, cover (21), and gasket (20). Inspect the condition of the gasket. Replace the gasket, if necessary. Remove crankshaft gear (14) from the crankshaft.

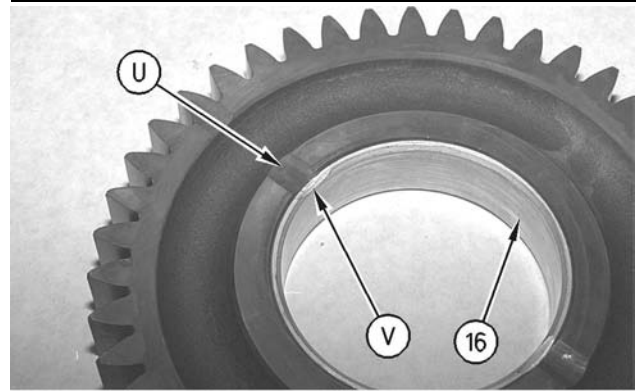

Illustration 145

g00760232

4. Remove bolts (18) and (19), idler shaft (17), and idler gear (15).

Note: Inspect the condition of the bearing. If necessary, remove bearing (16) from the gear with Tooling (B). Bearing Relief Groove (U) must line up with the Relief Groove (V) in gear (15) within two degrees. Bearing (16) must not extend beyond either face of gear.

5. Remove bolts (12), cover (10), and PTO shaft (5).
6. Remove thrust washer (2).

Note: Inspect the condition of bearing (3). If necessary, remove bearing (3) with Tooling (D). Refer to Disassembly and Assembly, "Rear Power Take-Off (RPTO) - Assemble" for installation of bearing.

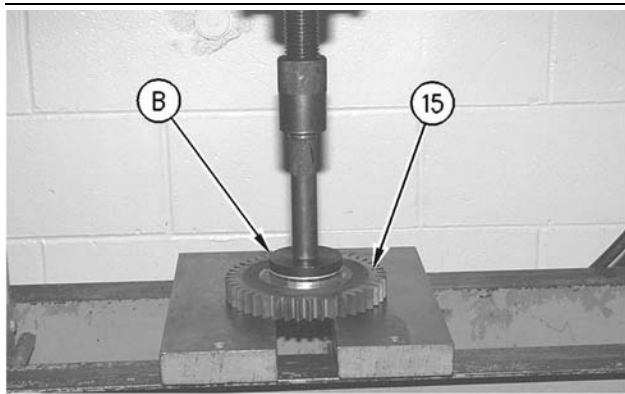

Illustration 144

g00759678

i01747504

Rear Power Take-Off (RPTO) - Assemble

SMCS Code: 1165-016-RE

Installation Procedure

Table 32

Required Tools			
Tool	Part Number	Part Description	Qty
A	6V - 8004 (1)	Guide Bolt	2
B	1P-0520	Driver Group	1
C	1P-0510	Driver Group	1

(1) Cut off the head of 6V - 8004 Bolt and chamfer edges.

NOTICE

Keep all parts clean from contaminants.

Contaminants may cause rapid wear and shortened component life.

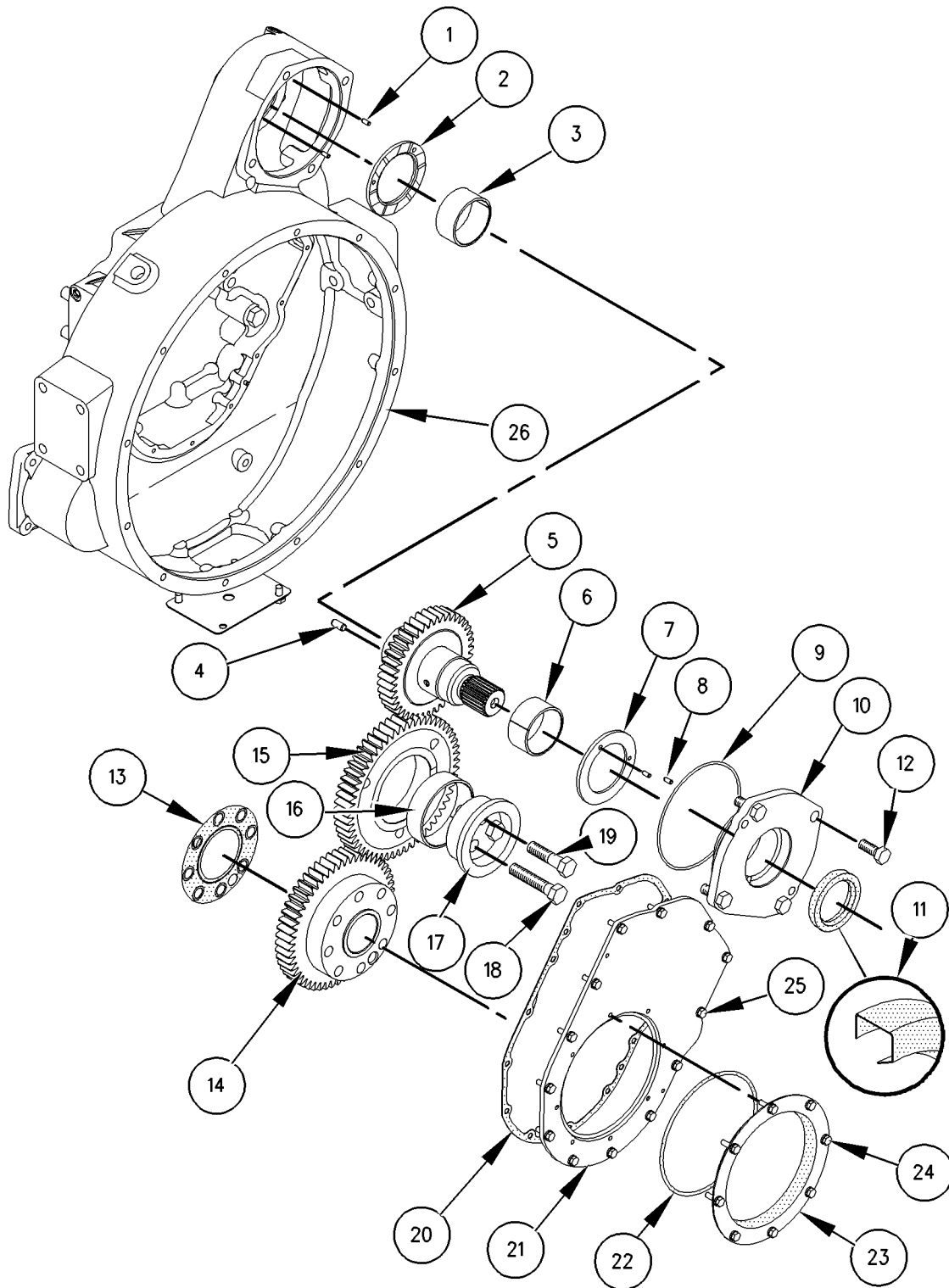

Illustration 146

g00757656

- | | | |
|--------------------|-----------------------|--------------------------------------|
| (1) Dowel | (10) Adapter Assembly | (19) Bolt |
| (2) Thrust Washer | (11) Lip Seal | (20) Gasket |
| (3) Sleeve Bearing | (12) Bolt | (21) Cover |
| (4) Dowel | (13) Seal | (22) Seal |
| (5) Gear Assembly | (14) Gear Assembly | (23) Cover |
| (6) Sleeve Bearing | (15) Gear Assembly | (24) Bolt |
| (7) Thrust Washer | (16) Sleeve Bearing | (25) Bolt |
| (8) Dowel | (17) Shaft | (26) Housing for Rear Power Take-Off |
| (9) Seal | (18) Bolt | |

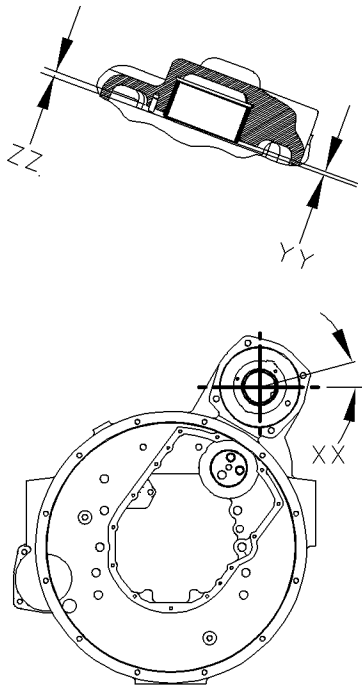

Illustration 147

g00759999

(XX) location of bearing joint
(YY) height of bearing
(ZZ) height of dowel

1. Use Tooling (B) to install bearing (3) in the housing for the Rear Power Take-Off (26).

Note: The bearing joint is located at an Angle (XX) that is 15 ± 3 degrees from the horizontal centerline. The oil hole in the bearing must align with the oil gallery in the housing for the RPTO. The bearing should extend beyond the surface of the housing for the RPTO by a Distance (YY) of $3.1 \pm .5$ mm (0.12 ± 0.02 inch).

2. Install dowels (1) in the RPTO housing (26).

Note: The dowels should extend beyond the surface of the RPTO housing by a distance $3.5 \pm .2$ mm (0.14 ± 0.01 inch).

3. Install thrust washer (2) into RPTO housing (26).

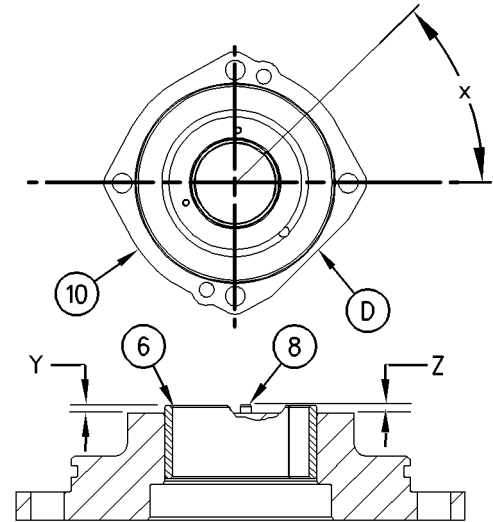

Illustration 148

g00759921

(D) The flat side of Adapter Assembly (10)
(X) location of bearing joint
(Y) height of bearing
(Z) height of dowel

4. Place adapter assembly (10) on the work surface. The outside face should be down. Install bearing (6) in adapter assembly (10) with Tooling (B).

Note: The split in the bearing should be located at Angle (X), which is 45 ± 10 degrees from the centerline in the adapter assembly (10). The bearing should extend beyond the surface of the adapter assembly (10) by a Distance (Y) which is 3.1 ± 0.5 mm (0.12 ± 0.02 inch).

5. Install dowels (8) and thrust washer (7) in adapter assembly (10). Refer to Illustration 146.

Note: The dowels should extend beyond the surface of the adapter assembly (10) by a distance of 3.5 ± 0.2 mm (0.14 ± 0.01 inch).

6. Install O-ring seal (9) on adapter assembly (10).

7. Turn over adapter assembly (10). Use Tooling (C) to install lip type seal (11). Lubricate lip type seal (11) lightly with the lubricant that is being sealed.

Note: Lip seal (11) should be installed to a depth of 2.5 ± 0.5 mm (0.1 ± 0.02 inch).

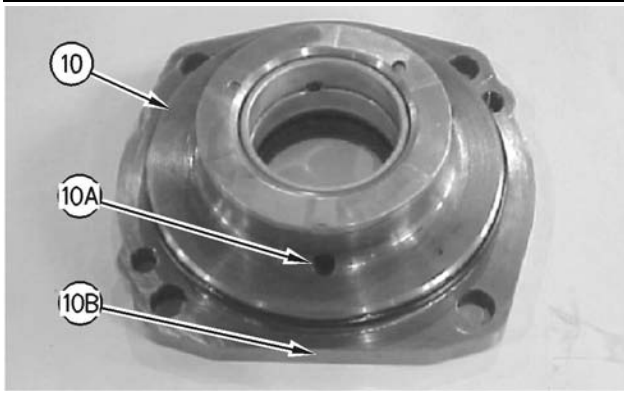

Illustration 149

g00759811

Note: Ensure that flat side (10B) of cover (10) is against the flywheel housing. This will ensure that oil passage (10A) is located toward the flywheel housing.

8. Install PTO shaft (5) and adapter assembly (10) into RPTO housing (26) and install bolts (12).

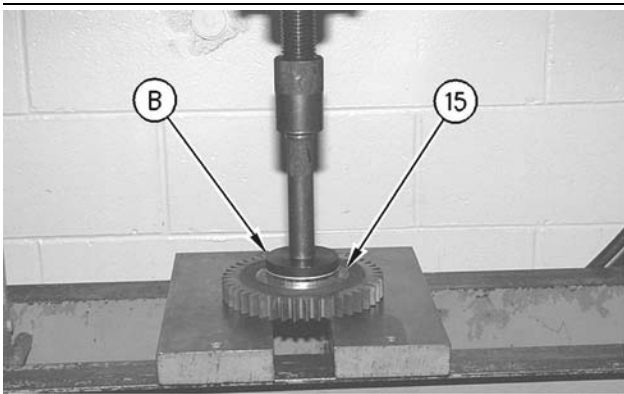

Illustration 150

g00760157

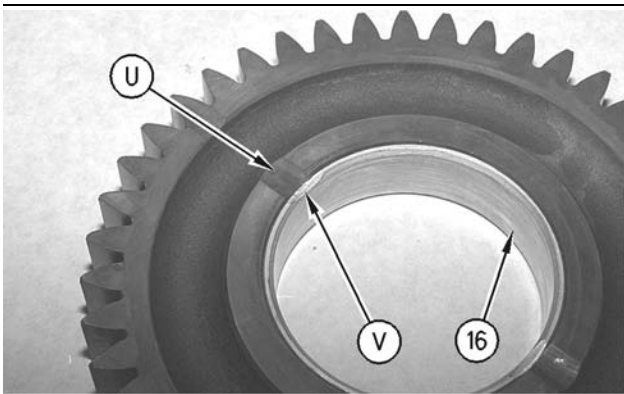

Illustration 151

g00760159

9. Install bearing (16) in gear (15) with Tooling (B).

Note: Bearing Relief Groove (U) must line up with the Relief Groove (V) in gear (15) within two degrees. Bearing (16) must not extend beyond either face of gear.

10. Install idler gear (15) on idler shaft (17). Install the shaft and gear assembly in the flywheel housing. Start with the bolt that is marked T. Tighten bolts (18) and (19) in a clockwise position to a torque of 100 N·m (74 lb ft). Again tighten bolts to a torque of 175 N·m (130 lb ft).

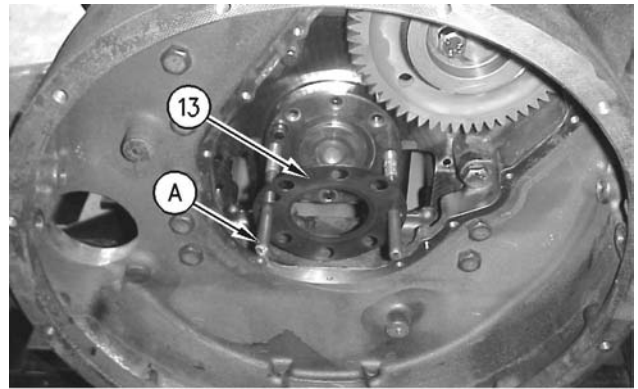

Illustration 152

g00759821

11. Install Tooling (A) in the crankshaft. Install gasket (13) and crankshaft gear (14).
12. Install the gasket (20), cover (21), bolts (25), and the washers.
13. Install O-ring seal (22), crankshaft rear seal (23), and bolts (24).

End By:

- a. Install the flywheel. Refer to Disassembly and Assembly, "Flywheel - Install".

i01336764

Vibration Damper and Pulley - Remove and Install

SMCS Code: 1205-010

Removal Procedure

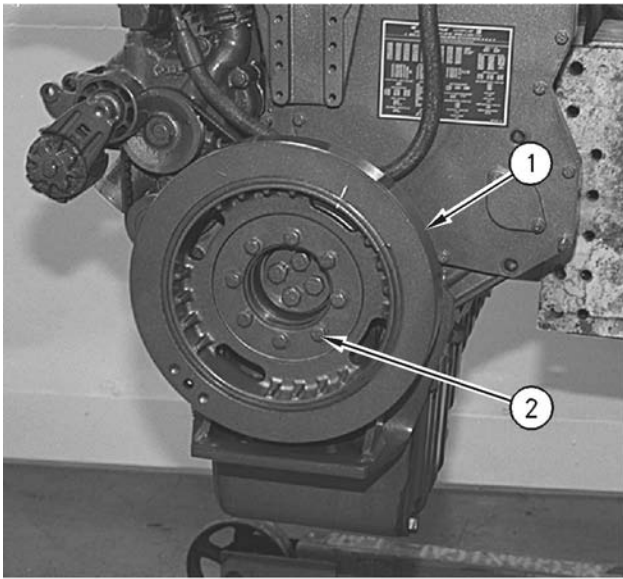

Illustration 153

g00612677

1. Remove eight bolts (2), crankshaft vibration damper (1), and two spacers from the crankshaft pulley.

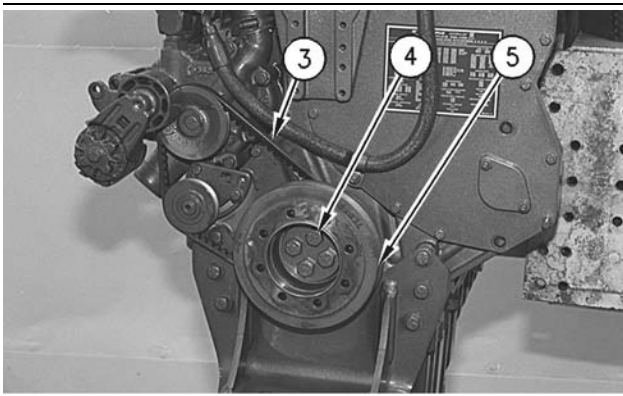

Illustration 154

g00612684

2. Loosen the tension on water pump drive belt (3). Remove the belt from the crankshaft pulley.
3. Remove four bolts (4) and the washer.
4. Remove crankshaft pulley (5).

Installation Procedure

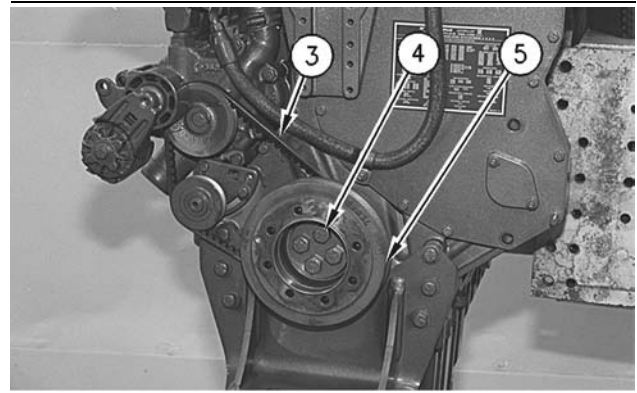

Illustration 155

g00612684

1. Position crankshaft pulley (5) on the crankshaft. Install four bolts (4) and tighten the bolts to a torque of 160 ± 30 N·m (118 ± 22 lb ft).
2. Install water pump drive belt (3).

Note: Check the alignment marks on the rubber vibration dampers for proper alignment. The rubber vibration damper should be replaced if the rubber vibration damper is out of alignment. Refer to Specifications, "Vibration Damper".

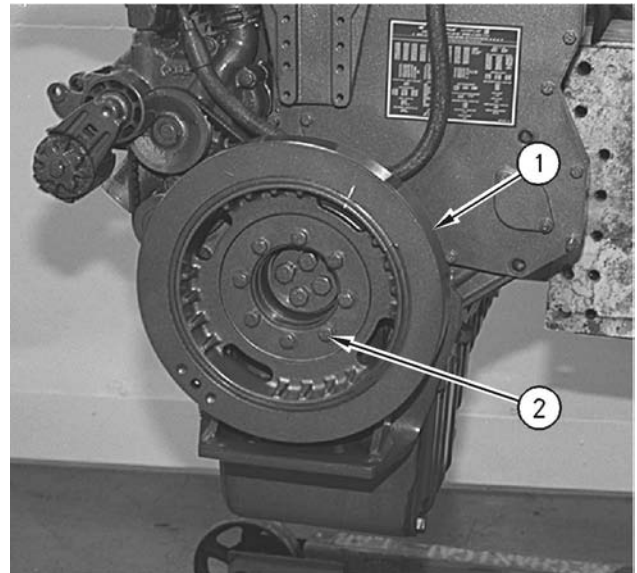

Illustration 156

g00612677

3. Install two spacers and crankshaft vibration damper (1). Tighten eight bolts (2) to a torque of 55 ± 10 N·m (40 ± 7 lb ft).
4. Adjust the tension of water pump drive belt (3). Refer to the Specifications Module, "Belt Tension Chart". Also, refer to the Operation and Maintenance Manual, "Belt - Inspect".

i01747605

i01747620

Crankshaft Front Seal - Remove

SMCS Code: 1160-011

Removal Procedure

Table 33

Required Tools			
Tool	Part Number	Part Description	Qty
A	1U-7600	Slide Hammer Puller	1
B	1U-8145	Drill Bit	1

Start By:

- a. Remove the vibration damper and the pulley. Refer to Disassembly and Assembly, "Vibration Damper and Pulley - Remove and Install".

NOTICE

Keep all parts clean from contaminants.

Contaminants may cause rapid wear and shortened component life.

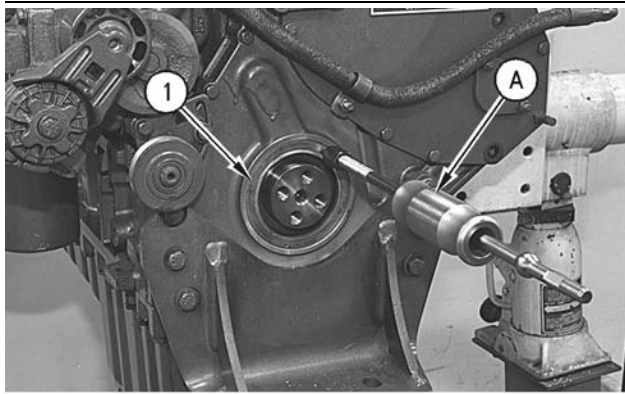

Illustration 157

g00612597

Note: Do not damage the flange of the crankshaft during the removal of the seal.

1. Use Tooling (B) and carefully drill three evenly spaced holes in crankshaft front seal (1).
2. Alternate between the drilled holes and use Tooling (A) to remove crankshaft front seal (1).

Crankshaft Front Seal - Install

SMCS Code: 1160-012

Installation Procedure

Table 34

Required Tools			
Tool	Part Number	Part Description	Qty
A	1U-7430	Front Seal Installer	1

NOTICE

Keep all parts clean from contaminants.

Contaminants may cause rapid wear and shortened component life.

Note: Ensure that the flange of the crankshaft and the front housing are thoroughly clean before you install the crankshaft front seal.

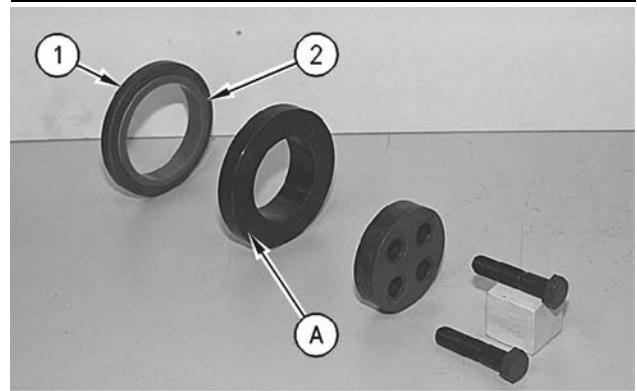

Illustration 158

g00612634

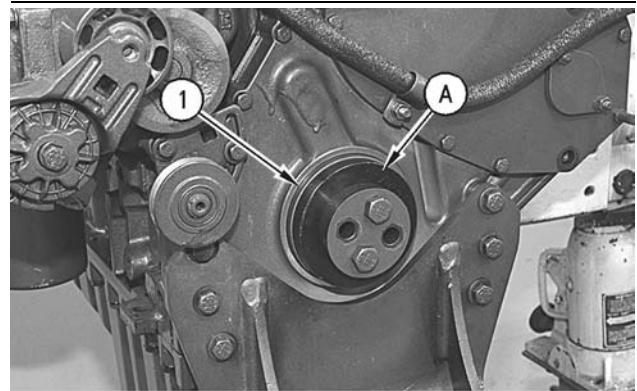

Illustration 159

g00612636

Note: Refer to Specifications, "Crankshaft Seals" for information on the distance between the following items: the front face of the crankshaft front seal and the front face of the front housing.

1. Position installation sleeve (2). Use Tooling (A) to install crankshaft front seal (1).

Note: The crankshaft seal is designed to be installed dry.

2. Remove installation sleeve (2) from the crankshaft front seal. Ensure that the seal surface of the crankshaft pulley is thoroughly clean and dry. Ensure that the seal surface of the crankshaft pulley is in good condition.

End By:

- a. Install the vibration damper and the pulley. Refer to Disassembly and Assembly, "Vibration Damper and Pulley - Remove and Install".

i01153795

Front Cover - Remove

SMCS Code: 1166-011

Removal Procedure

Start By:

- a. Remove the fan drive. Refer to Disassembly and Assembly, "Fan Drive - Remove".

NOTICE

Keep all parts clean from contaminants.

Contaminants may cause rapid wear and shortened component life.

NOTICE

Care must be taken to ensure that fluids are contained during performance of inspection, maintenance, testing, adjusting and repair of the product. Be prepared to collect the fluid with suitable containers before opening any compartment or disassembling any component containing fluids.

Refer to Special Publication, NENG2500, "Caterpillar Tools and Shop Products Guide" for tools and supplies suitable to collect and contain fluids on Caterpillar products.

Dispose of all fluids according to local regulations and mandates.

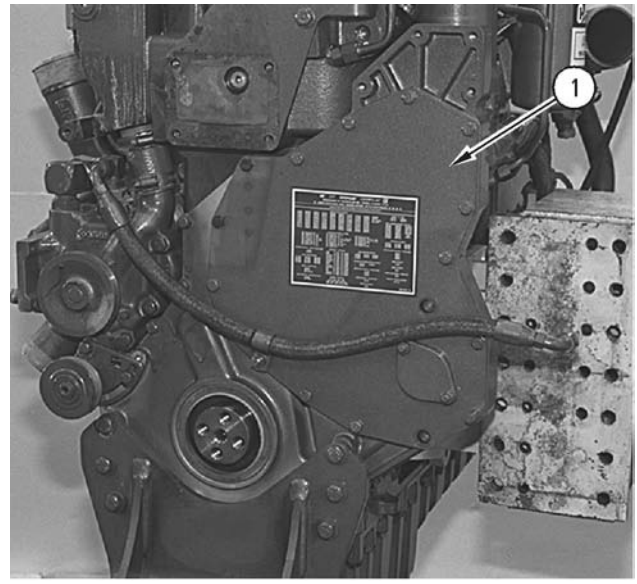

Illustration 160

g00612568

Note: The front pulley was removed and the damper was removed for better photographic illustration. The air compressor was removed in order to accommodate the engine repair stand.

1. Remove the bolts and front cover (1) from the front housing.

i01153809

Front Cover - Install

SMCS Code: 1166-012

Installation Procedure

NOTICE

Keep all parts clean from contaminants.

Contaminants may cause rapid wear and shortened component life.

Note: The rear face of the cover and the front face of the housing must be clean.

1. Inspect the condition of the housing cover gasket. Replace the gasket, if necessary.

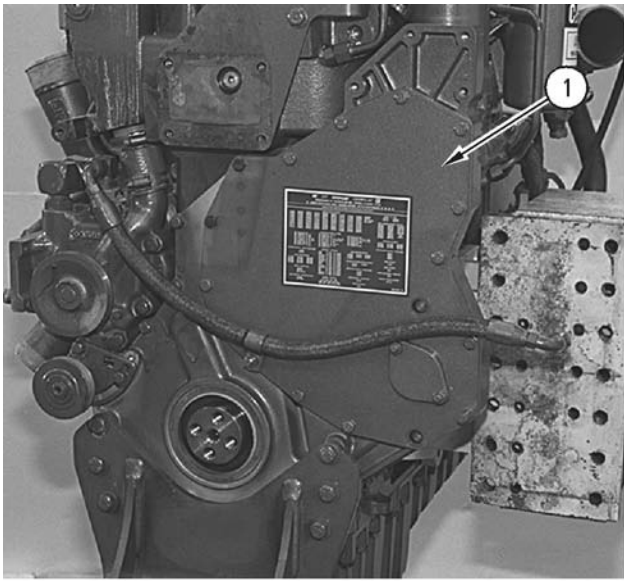

Illustration 161

g00612568

2. Install the housing cover gasket.
3. Position front cover (1) on the front housing. Install the bolts on front cover (1).

End By:

- a. Install the fan drive. Refer to Disassembly and Assembly, "Fan Drive - Install".

i01153309

Housing (Front) - Remove

SMCS Code: 1151-011

Removal Procedure

Start By:

- a. Remove the crankshaft vibration damper. Refer to Disassembly and Assembly, "Vibration Damper and Pulley - Remove and Install".
- b. Remove the crankshaft front seal. Refer to Disassembly and Assembly, "Crankshaft Front Seal - Remove".
- c. Remove the camshaft. Refer to Disassembly and Assembly, "Camshaft - Remove".

NOTICE

Care must be taken to ensure that fluids are contained during performance of inspection, maintenance, testing, adjusting and repair of the product. Be prepared to collect the fluid with suitable containers before opening any compartment or disassembling any component containing fluids.

Refer to Special Publication, NENG2500, "Caterpillar Tools and Shop Products Guide" for tools and supplies suitable to collect and contain fluids on Caterpillar products.

Dispose of all fluids according to local regulations and mandates.

1. Remove any external components, if equipped.

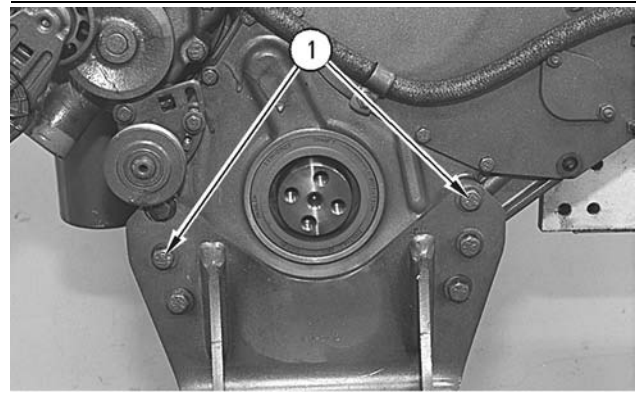

Illustration 162

g00615717

2. Remove five bolts (1) and remove front engine support.

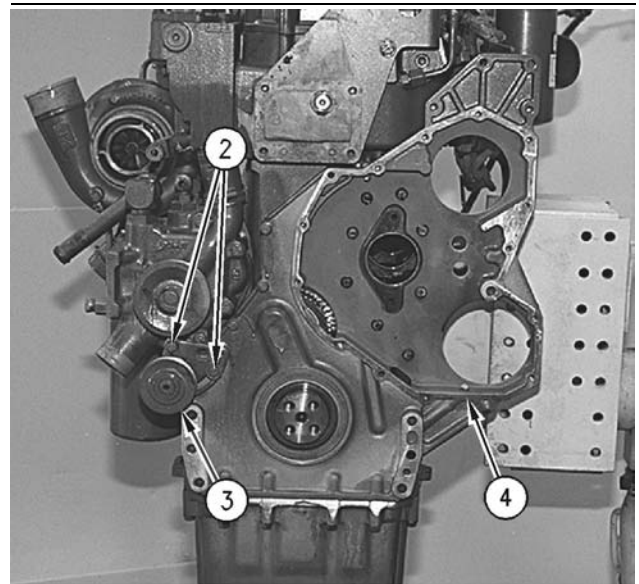

Illustration 163

g00612359

3. Remove two bolts (2) and belt tightener (3).

4. Remove the bolts that fasten front housing (4) to the cylinder block and to the engine oil pan. Remove front housing (4). Clean the sealant from front housing (4) and the cylinder block.

i01336821

Housing (Front) - Install

SMCS Code: 1151-012

Installation Procedure

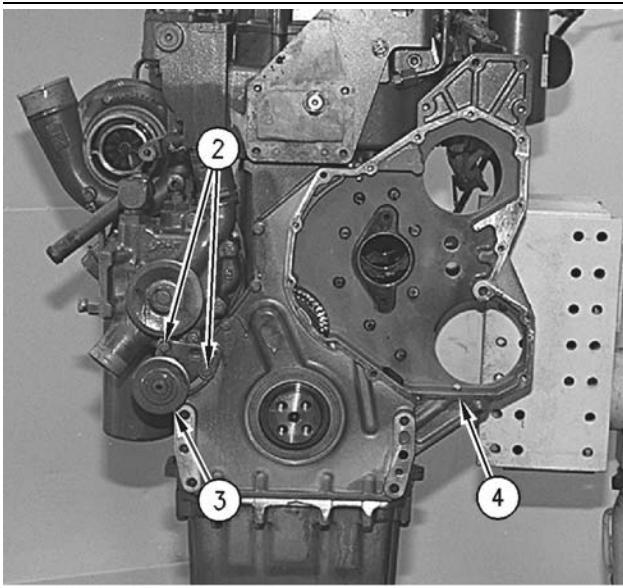

Illustration 164

g00612359

1. Clean the joint face on front housing (4) with 8T-9011 Component Cleaner.
2. Apply 4C-9500 Quick Cure Primer to the joint face. Allow the primer to dry for at least three to five minutes.

Note: Do not allow the 1U-8846 Sealant to seal the main oil passage on front housing (4).

3. Apply 1U-8846 Sealant to the joint face. Spread the sealant uniformly. Front housing (4) must be installed within ten minutes of applying the sealant.
4. Position front housing (4) on the cylinder block.
5. Install the bolts that fasten front housing (4) to the cylinder block and the engine oil pan.
6. Position belt tightener (3) and install two bolts (2).

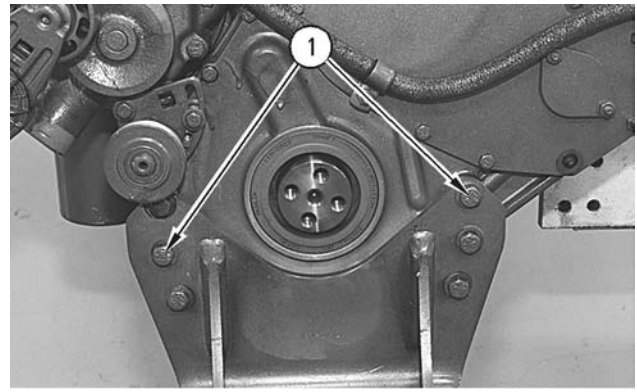

Illustration 165

g00615717

7. Position the front engine support and install five bolts (1).
8. Install any external components, if equipped.

End By:

- a. Install the camshaft. Refer to Disassembly and Assembly, "Camshaft - Install".
- b. Install the crankshaft front seal. Refer to Disassembly and Assembly, "Crankshaft Front Seal - Install".
- c. Install the crankshaft vibration damper. Refer to Disassembly and Assembly, "Vibration Damper and Pulley - Remove and Install".

i01747653

Camshaft Idler Gear - Remove and Install

SMCS Code: 1206-010

Removal Procedure

Table 35

Required Tools			
Tool	Part Number	Part Description	Qty
A	1P-0520	Driver Group	1

Start By:

- a. Remove the front housing. Refer to Disassembly and Assembly, "Housing (Front) - Remove".

NOTICE

Keep all parts clean from contaminants.

Contaminants may cause rapid wear and shortened component life.

NOTICE

Care must be taken to ensure that fluids are contained during performance of inspection, maintenance, testing, adjusting and repair of the product. Be prepared to collect the fluid with suitable containers before opening any compartment or disassembling any component containing fluids.

Refer to Special Publication, NENG2500, "Caterpillar Tools and Shop Products Guide" for tools and supplies suitable to collect and contain fluids on Caterpillar products.

Dispose of all fluids according to local regulations and mandates.

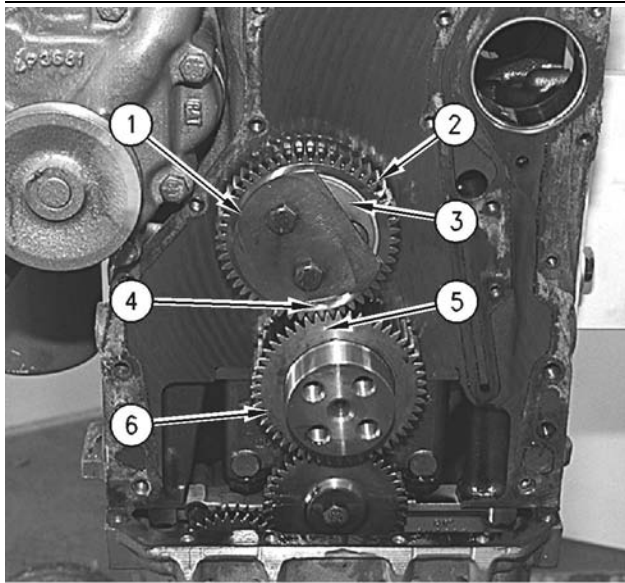

Illustration 166

g00616185

1. Rotate the crankshaft until the number one piston is at the top center position. Timing mark (4) for camshaft idler gear (2) should be in line with timing mark (5) for crankshaft drive gear (6). Identify the location of timing mark (4) for camshaft idler gear (2) and timing mark (5) for crankshaft drive gear (6).
2. Remove the two bolts that fasten plate (1) to idler shaft (3). Remove plate (1).

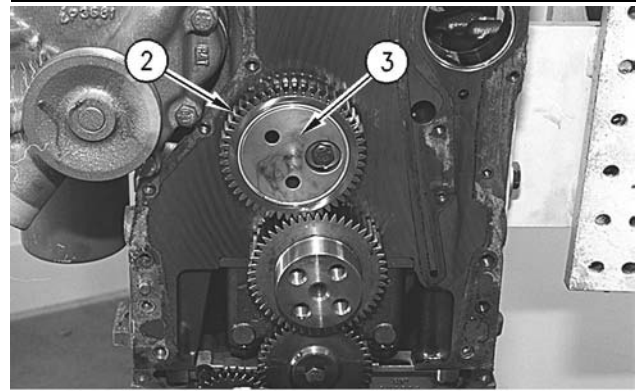

Illustration 167

g00616226

3. Slide camshaft idler gear (2) from idler shaft (3).
4. Remove the bolt and idler shaft (3) from the cylinder block.

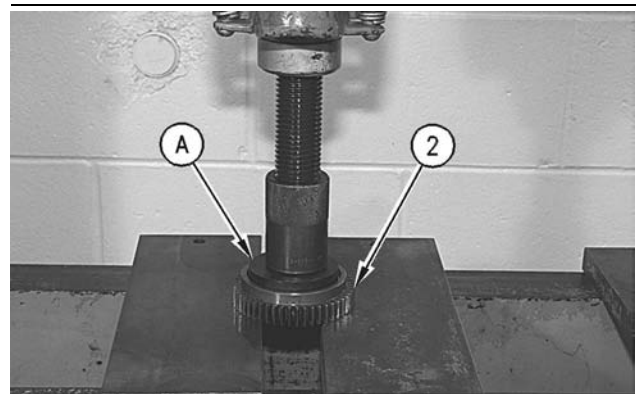

Illustration 168

g00616240

5. Use Tooling (A) and a press to remove the bearing from camshaft idler gear (2).

Installation Procedure

Table 36

Required Tools			
Tool	Part Number	Part Description	Qty
A	1P-0520	Driver Group	1

NOTICE

Keep all parts clean from contaminants.

Contaminants may cause rapid wear and shortened component life.

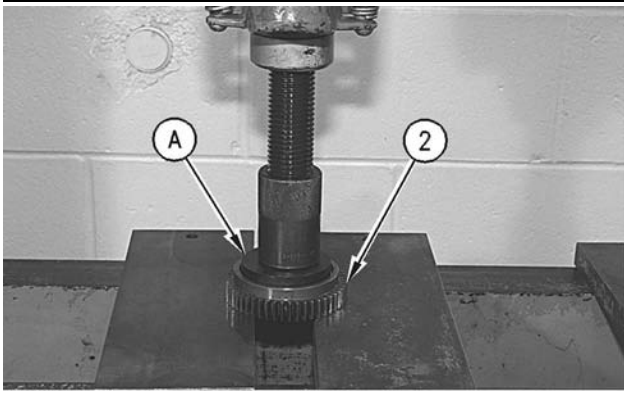

Illustration 169

g00616240

1. Use Tooling (A) and a press to install the bearing in camshaft idler gear (2). Install the bearing until the bearing is 0.40 ± 0.25 mm (0.016 ± 0.010 inch) below the front face of camshaft idler gear (2).

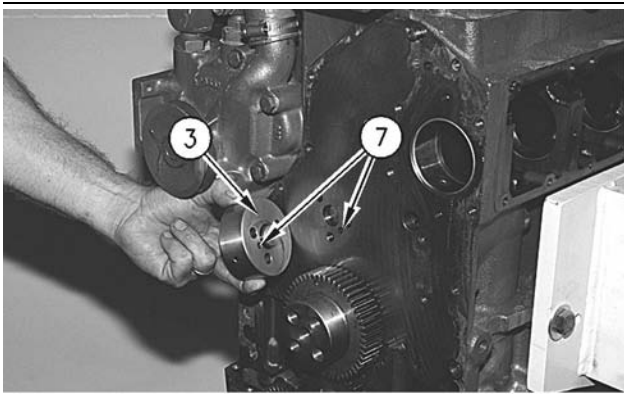

Illustration 170

g00616246

2. Ensure that oil supply passages (7) in the cylinder block and idler shaft (3) are free of contaminants. Position idler shaft (3) on the cylinder block. Install the bolt that holds idler shaft (3) to the cylinder block. Tighten the bolt to a torque of 70 ± 15 N·m (51 ± 11 lb ft).

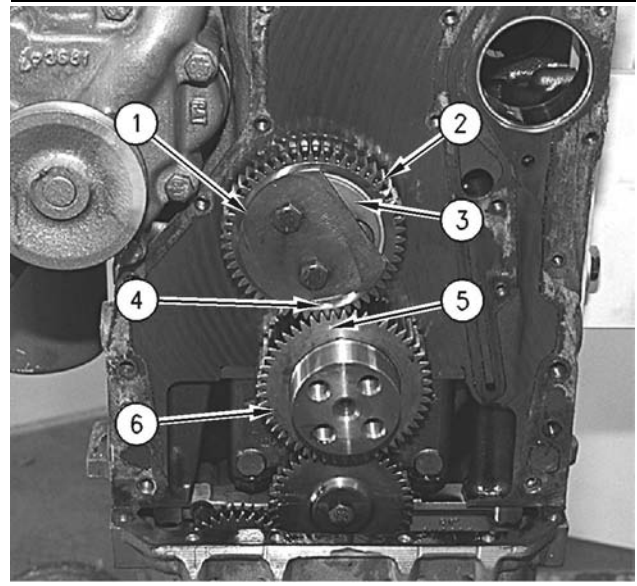

Illustration 171

g00616185

3. Install camshaft idler gear (2) on idler shaft (3). Ensure that timing mark (4) for camshaft idler gear (2) is facing outward. Align the identified timing mark (4) for camshaft idler gear (2) with the identified timing mark (5) for crankshaft drive gear (6).
4. Position plate (1) and install two bolts. Tighten the bolts to a torque of 70 ± 15 N·m (51 ± 11 lb ft).

End By:

- a. Install the front housing. Refer to Disassembly and Assembly, "Housing (Front) - Install".

i01516145

Valve Mechanism Cover - Remove and Install

SMCS Code: 1107-010

Removal Procedure

NOTICE

Keep all parts clean from contaminants.

Contaminants may cause rapid wear and shortened component life.

NOTICE

Care must be taken to ensure that fluids are contained during performance of inspection, maintenance, testing, adjusting and repair of the product. Be prepared to collect the fluid with suitable containers before opening any compartment or disassembling any component containing fluids.

Refer to Special Publication, NENG2500, "Caterpillar Tools and Shop Products Guide" for tools and supplies suitable to collect and contain fluids on Caterpillar products.

Dispose of all fluids according to local regulations and mandates.

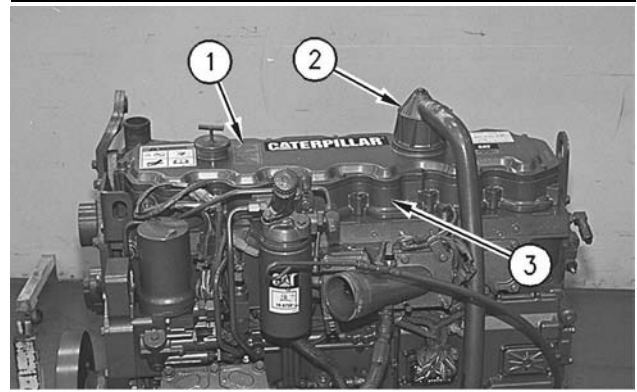

Illustration 173

g00611536

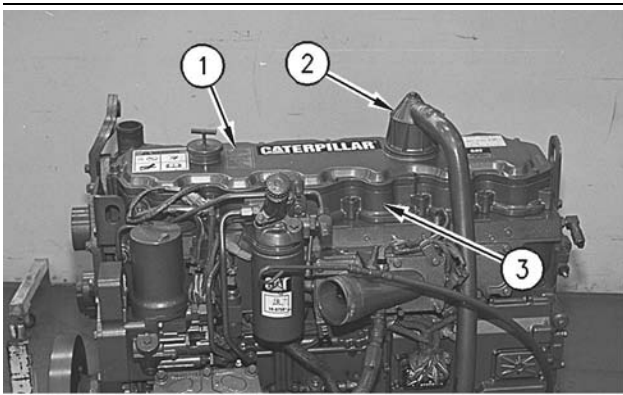

Illustration 172

g00611536

1. Remove breather assembly (2) from valve mechanism cover (1).
2. Remove the bolts that hold valve mechanism cover (1) to valve mechanism cover base (3).
3. Remove the seal from the valve mechanism cover.

Installation Procedure

NOTICE

Keep all parts clean from contaminants.

Contaminants may cause rapid wear and shortened component life.

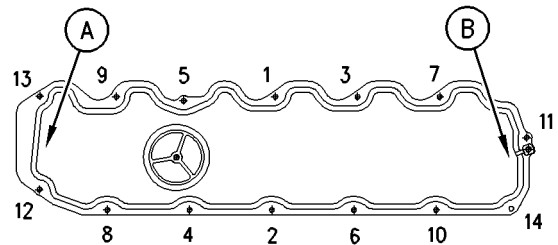

Illustration 174

g00786705

Bolt tightening sequence for the valve mechanism cover

- (A) Rear
- (B) Front

1. Position valve mechanism cover (1) and the seal on valve mechanism cover base (3). Cut the seal to length. Apply **4C-9612** Silicone Sealant on both sides of the seal joint.
2. Install the bolts. Tighten the bolts in a numerical sequence to a torque of 12 ± 3 N·m (106 ± 27 lb in).

Note: Inspect the O-ring seal of the breather assembly. Replace the O-ring seal, if necessary.

3. Position breather assembly (2) on valve mechanism cover (1). Tighten the bolt for breather assembly (2) to a torque of 7 ± 2 N·m (62 ± 18 lb in).

i01516146

Valve Mechanism Cover Base - Remove and Install

SMCS Code: 1120-010

Removal Procedure

Start By:

- a. Remove the valve mechanism cover. Refer to Disassembly and Assembly, "Valve Mechanism Cover - Remove and Install".

NOTICE

Keep all parts clean from contaminants.

Contaminants may cause rapid wear and shortened component life.

NOTICE

Care must be taken to ensure that fluids are contained during performance of inspection, maintenance, testing, adjusting and repair of the product. Be prepared to collect the fluid with suitable containers before opening any compartment or disassembling any component containing fluids.

Refer to Special Publication, NENG2500, "Caterpillar Tools and Shop Products Guide" for tools and supplies suitable to collect and contain fluids on Caterpillar products.

Dispose of all fluids according to local regulations and mandates.

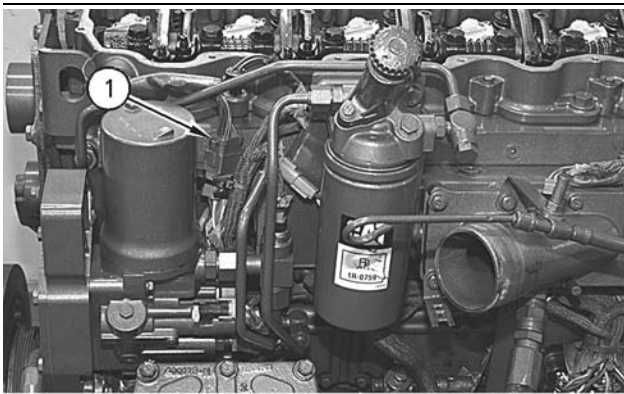

Illustration 175

g00611576

1. Disconnect plug (1) from the wiring harness.

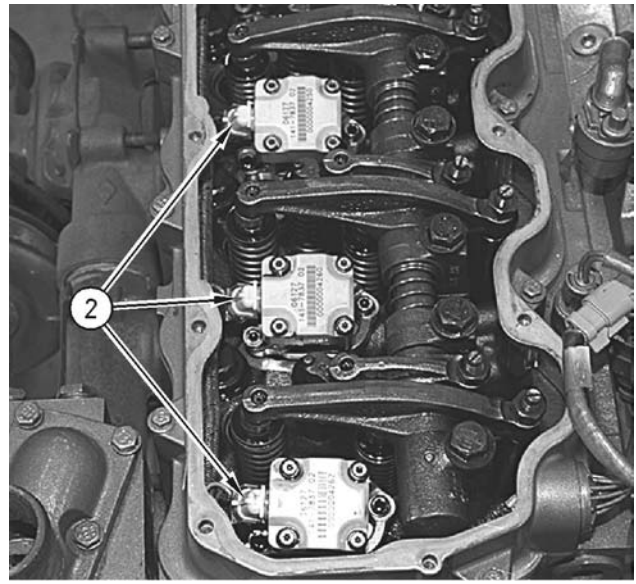

Illustration 176

g00611577

2. Disconnect wiring harness plugs (2) from each of the unit injectors.

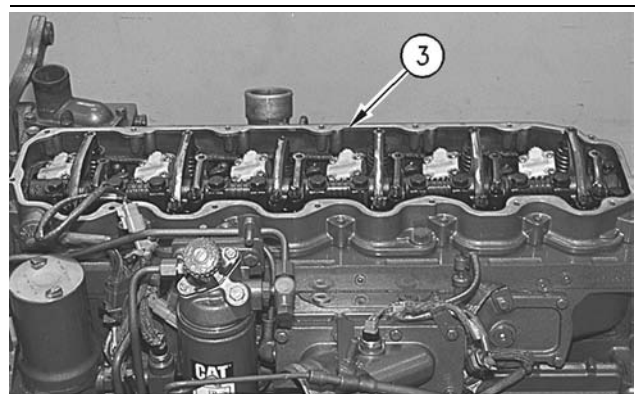

Illustration 177

g00611578

3. Remove the bolts and base (3) of the valve mechanism cover from the cylinder head.

Installation Procedure

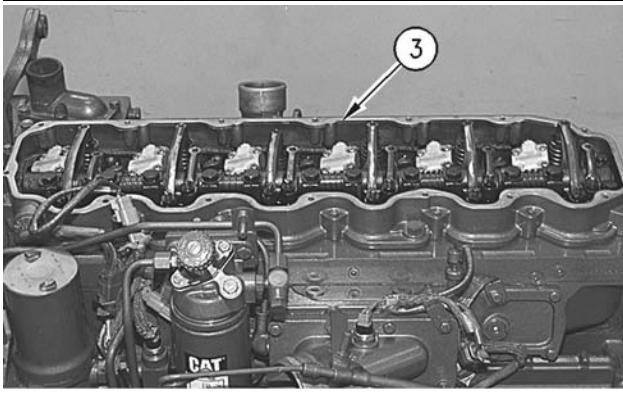

Illustration 178

g00611578

1. Ensure that the mating surface of base (3) of the valve mechanism cover and the cylinder head are thoroughly clean.
2. Position base (3) of the valve mechanism cover on the cylinder head. Install the bolts and tighten the bolts in a numerical sequence to a torque of 12 ± 3 N·m (106 ± 27 lb in).

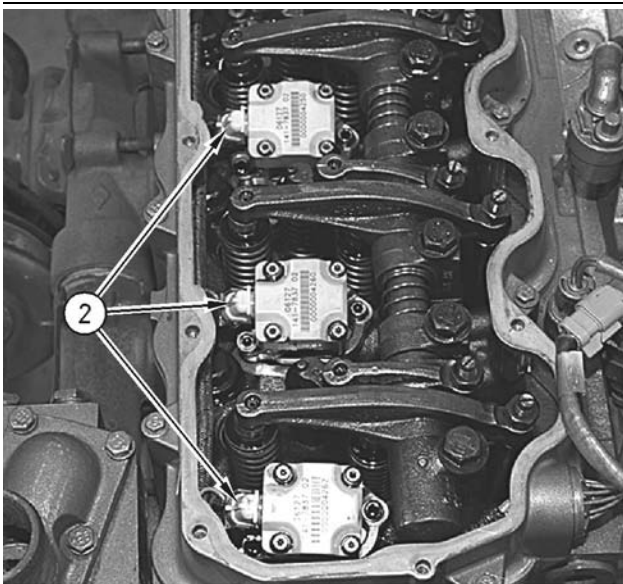

Illustration 179

g00611577

3. Connect wiring harness plugs (2) to each of the unit injectors.

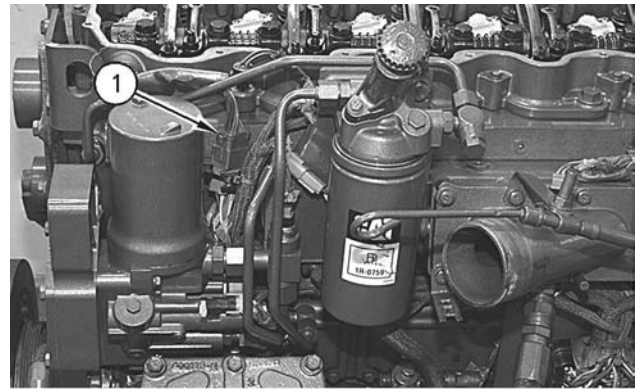

Illustration 180

g00611576

4. Connect plug (1) to the wiring harness.

End By:

- a. Install the valve mechanism cover. Refer to Disassembly and Assembly, "Valve Mechanism Cover - Remove and Install".

i01152050

Rocker Shaft and Pushrod - Remove

SMCS Code: 1102-011; 1208-011

Removal Procedure

Start By:

- a. Remove the valve mechanism cover. Refer to Disassembly and Assembly, "Valve Mechanism Cover - Remove and Install".

NOTICE

Keep all parts clean from contaminants.

Contaminants may cause rapid wear and shortened component life.

NOTICE

Care must be taken to ensure that fluids are contained during performance of inspection, maintenance, testing, adjusting and repair of the product. Be prepared to collect the fluid with suitable containers before opening any compartment or disassembling any component containing fluids.

Refer to Special Publication, NENG2500, "Caterpillar Tools and Shop Products Guide" for tools and supplies suitable to collect and contain fluids on Caterpillar products.

Dispose of all fluids according to local regulations and mandates.

1. Put identification marks on each rocker arm in order to identify the proper location in the engine for installation.

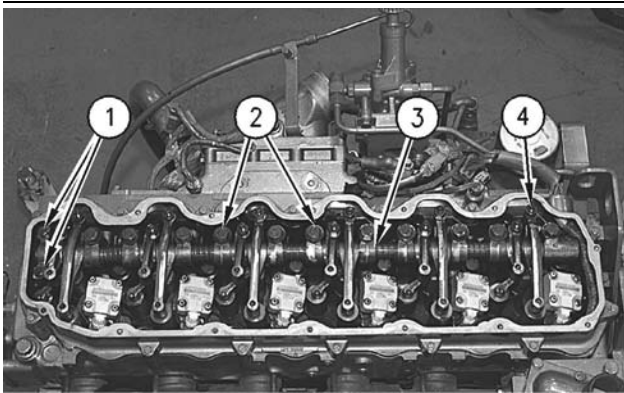

Illustration 181

g00611428

2. Loosen all rocker arm adjustment screws (4) in order to release the tension on the rocker shaft.
3. Remove two bolts (1), eleven bolts (2), and rocker shaft (3).

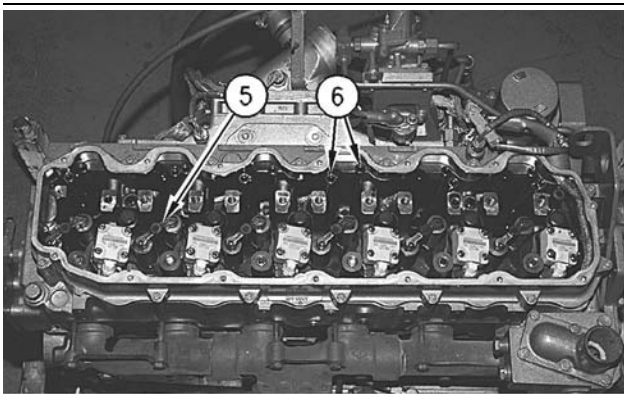

Illustration 182

g00611430

4. Remove inlet valve bridges (5) and pushrods (6).

Rocker Shaft - Disassemble

SMCS Code: 1102-015

Disassembly Procedure

Table 37

Required Tools			
Tool	Part Number	Part Description	Qty
A	1P-1855	Retaining Ring Pliers	1

Start By:

- a. Remove the rocker shaft. Refer to Disassembly and Assembly, "Rocker Shaft and Pushrod - Remove".

NOTICE

Keep all parts clean from contaminants.

Contaminants may cause rapid wear and shortened component life.

NOTICE

Care must be taken to ensure that fluids are contained during performance of inspection, maintenance, testing, adjusting and repair of the product. Be prepared to collect the fluid with suitable containers before opening any compartment or disassembling any component containing fluids.

Refer to Special Publication, NENG2500, "Caterpillar Tools and Shop Products Guide" for tools and supplies suitable to collect and contain fluids on Caterpillar products.

Dispose of all fluids according to local regulations and mandates.

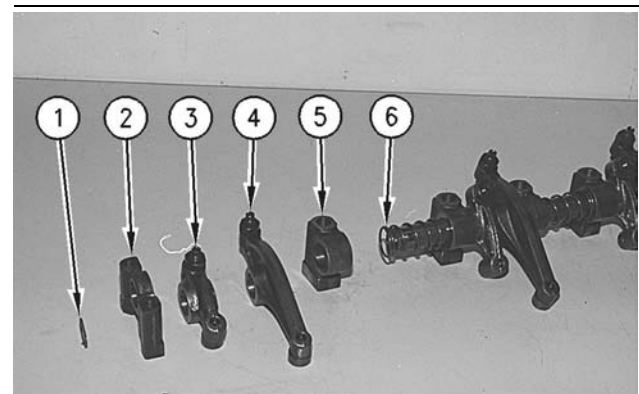

Illustration 183

g00611468

Note: Place an identification mark on each of the components of the rocker shaft for installation purposes.

1. Remove retaining ring (1) with Tooling (A).
2. Remove stand (2), inlet rocker arm (3), exhaust rocker arm (4), stand (5), and spring (6) from the rocker shaft.
3. Inspect all of the components of the rocker shaft for wear and damage. Replace the components of the rocker shaft, if necessary.

i01152128

Rocker Shaft - Assemble

SMCS Code: 1102-016

Assembly Procedure

Table 38

Required Tools			
Tool	Part Number	Part Description	Qty
A	1P-1855	Retaining Ring Pliers	1

NOTICE

Keep all parts clean from contaminants.

Contaminants may cause rapid wear and shortened component life.

NOTICE

Care must be taken to ensure that fluids are contained during performance of inspection, maintenance, testing, adjusting and repair of the product. Be prepared to collect the fluid with suitable containers before opening any compartment or disassembling any component containing fluids.

Refer to Special Publication, NENG2500, "Caterpillar Tools and Shop Products Guide" for tools and supplies suitable to collect and contain fluids on Caterpillar products.

Dispose of all fluids according to local regulations and mandates.

1. Lubricate all of the components of the rocker shaft with clean engine oil.

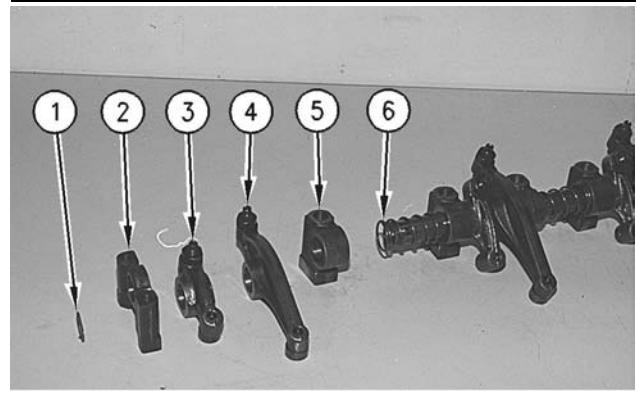

Illustration 184

g00611468

2. Install spring (6), stand (5), exhaust rocker arm (4), inlet rocker arm (3), and stand (2) on the rocker shaft.

3. Install retaining ring (1) with Tool (A).

End By:

- a. Install the rocker shaft. Refer to Disassembly and Assembly, "Rocker Shaft and Pushrod - Install".

i01152077

Rocker Shaft and Pushrod - Install

SMCS Code: 1102-012; 1208-012

Installation Procedure

NOTICE

Keep all parts clean from contaminants.

Contaminants may cause rapid wear and shortened component life.

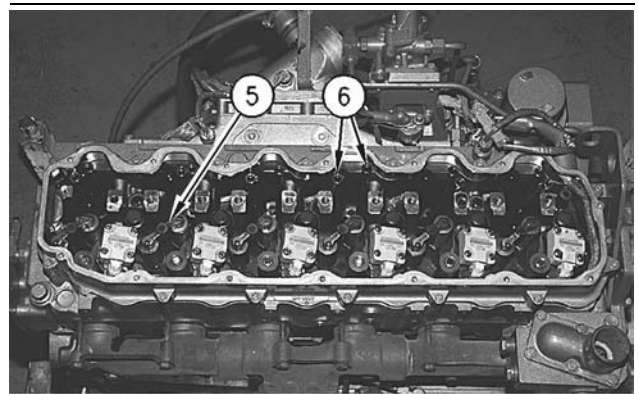

Illustration 185

g00611430

1. Apply 8T-2998 Lubricant to both ends of pushrods (6).

Note: Ensure that the pushrods are installed correctly in the socket of the tappets.

2. Lubricate pushrods (6) with clean engine oil. Install pushrods (6) and valve bridges (5).

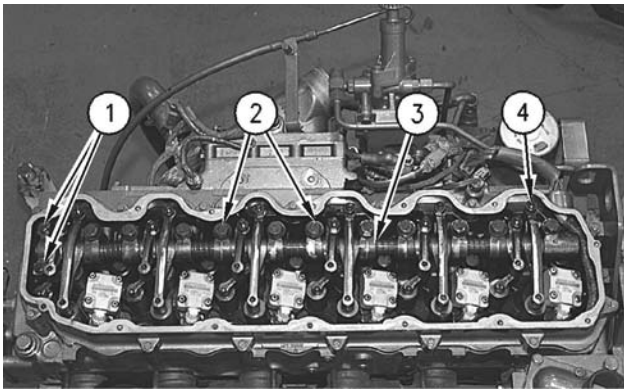

Illustration 186

g00611428

3. Position rocker shaft (3). Install bolts (1) and (2). Finger tighten bolts (1) and (2). Tighten bolts (2) to a torque of 100 ± 20 N·m (74 ± 15 lb ft). Tighten bolts (1) to a torque of 28 ± 7 N·m (21 ± 5 lb ft).
4. Apply 8T-2998 Lubricant to each of the button faces of the rocker arms.
5. Adjust the valve lash of the rocker arm. Refer to the Systems Operation/Testing and Adjusting.

End By:

- a. Install the valve mechanism cover. Refer to Disassembly and Assembly, "Valve Mechanism Cover - Remove and Install".

i01747702

Cylinder Head - Remove

SMCS Code: 1100-011

Removal Procedure

Start By:

- a. Remove the fan drive. Refer to Disassembly and Assembly, "Fan Drive - Remove".
- b. Remove the fuel filter base. Refer to Disassembly and Assembly, "Fuel Filter Base - Remove and Install".

- c. Remove the water temperature regulator housing. Refer to Disassembly and Assembly, "Water Temperature Regulator Housing - Remove and Install".
- d. Remove the unit injectors. Refer to Disassembly and Assembly, "Unit Injector - Remove".
- e. Remove the air inlet cover. Refer to Disassembly and Assembly, "Air Inlet Cover - Remove and Install".
- f. Remove the exhaust manifold. Refer to Disassembly and Assembly, "Exhaust Manifold - Remove and Install".

NOTICE

Keep all parts clean from contaminants.

Contaminants may cause rapid wear and shortened component life.

NOTICE

Care must be taken to ensure that fluids are contained during performance of inspection, maintenance, testing, adjusting and repair of the product. Be prepared to collect the fluid with suitable containers before opening any compartment or disassembling any component containing fluids.

Refer to Special Publication, NENG2500, "Caterpillar Tools and Shop Products Guide" for tools and supplies suitable to collect and contain fluids on Caterpillar products.

Dispose of all fluids according to local regulations and mandates.

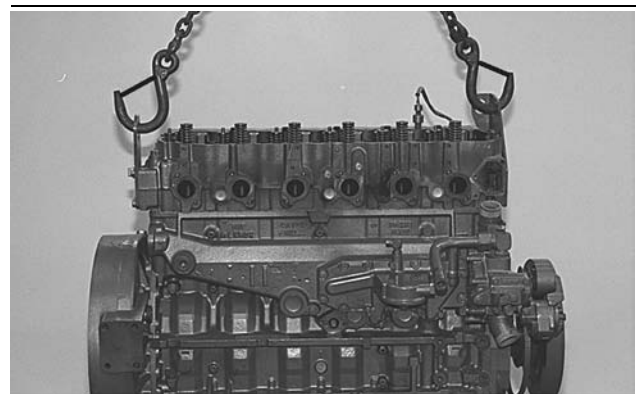

Illustration 187

g00746424

1. Attach a suitable lifting device to the cylinder head.

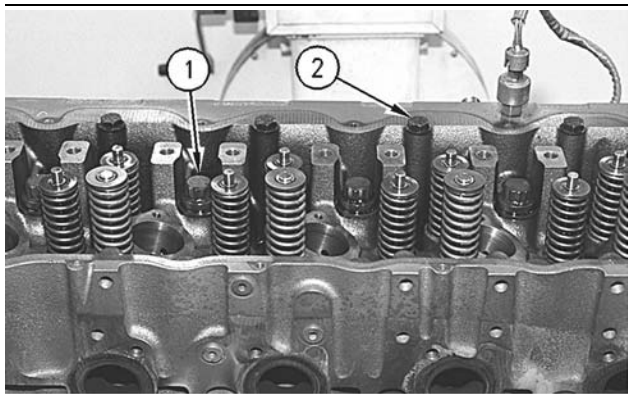

Illustration 188

g00611336

2. Remove bolts (1), bolts (2), and washers that hold the cylinder head to the cylinder block. Carefully remove the cylinder head from the cylinder block. The cylinder head weighs approximately 85 kg (187 lb).

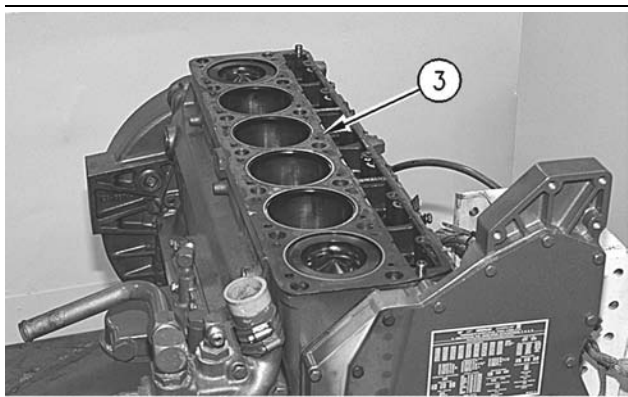

Illustration 189

g00611342

3. Remove cylinder head gasket (3).

i01624119

Cylinder Head - Install

SMCS Code: 1100-012

Installation Procedure

NOTICE

Keep all parts clean from contaminants.

Contaminants may cause rapid wear and shortened component life.

1. Thoroughly clean the mating surfaces of the cylinder head and the cylinder block.

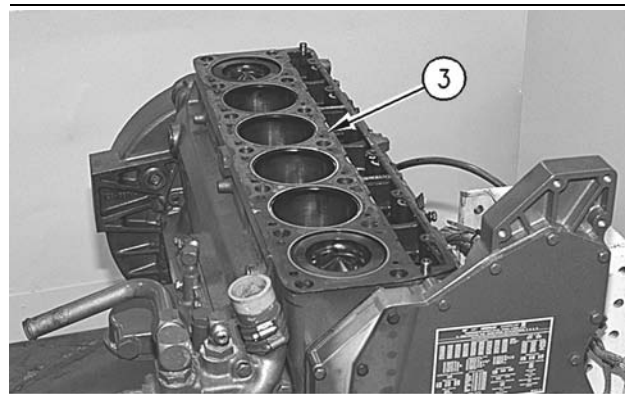

Illustration 190

g00611342

2. Install a new cylinder head gasket (3).

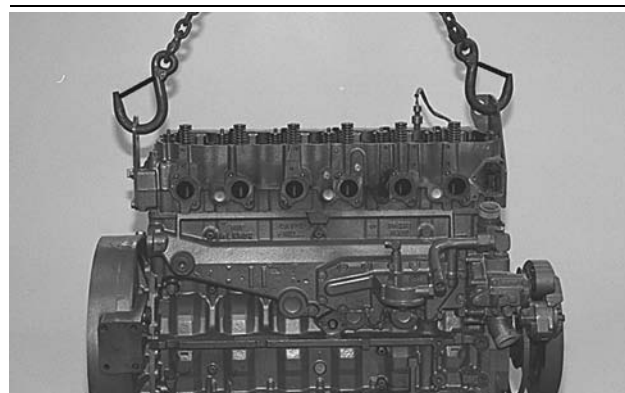

Illustration 191

g00746424

Note: To avoid damage to the cylinder head gasket, use guide bolts of an appropriate size to install the cylinder head.

3. Attach a suitable lifting device to the cylinder head. Position the cylinder head assembly onto the dowels in the cylinder block. Lower the cylinder head onto the cylinder block.

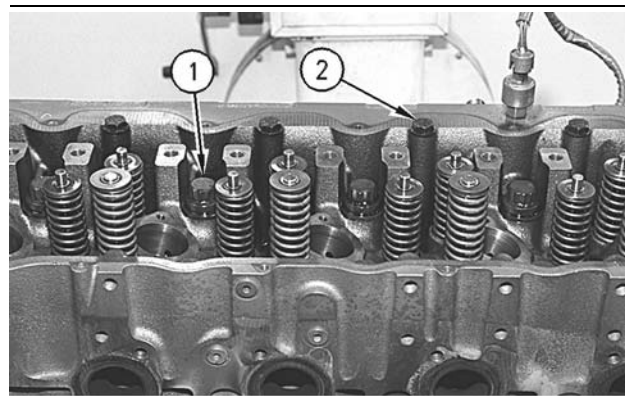

Illustration 192

g00611336

Typical example

4. Inspect the condition of cylinder head bolts (1) and (2). Replace cylinder head bolts (1) and (2), if necessary.
5. Lubricate the cylinder head bolts (1) and (2) and the washers with 6V-4876 Lubricant. Install cylinder head bolts (1) and (2). Follow Step 6 for the correct tightening procedure.

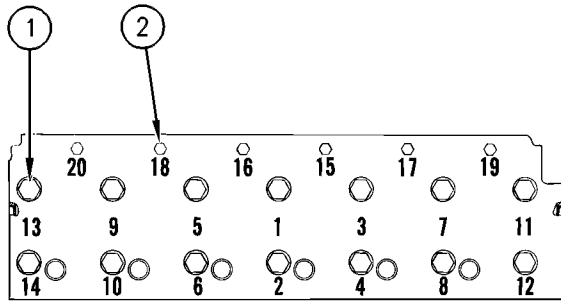

Illustration 193

g00611358

6. Tighten the cylinder head bolts according to the following procedure:
 - a. Tighten bolt (1) through bolt (14) in a numerical sequence to a torque of 300 ± 15 N·m (221 ± 11 lb ft).
 - b. Loosen bolt (1) through bolt (14) until the washers are loose under the bolt heads.
 - c. Tighten bolt (1) through bolt (14) again in a numerical sequence to a torque of 130 ± 15 N·m (95 ± 11 lb ft).
 - d. Again tighten bolt (1) through bolt (14) in a numerical sequence to a torque of 130 ± 15 N·m (95 ± 11 lb ft).
 - e. Turn bolt (1) through bolt (14) in a numerical sequence for an additional 90° ($1/4$ turn).
 - f. Tighten bolt (15) through bolt (20) in a numerical sequence to a torque of 55 ± 7 N·m (41 ± 5 lb ft).

End By:

- a. Install the exhaust manifold. Refer to Disassembly and Assembly, "Exhaust Manifold - Remove and Install".
- b. Install the air inlet cover. Refer to Disassembly and Assembly, "Air Inlet Cover - Remove and Install".

- c. Install the unit injectors. Refer to Disassembly and Assembly, "Unit Injector - Install".
- d. Install the water temperature regulator housing. Refer to Disassembly and Assembly, "Water Temperature Regulator Housing - Remove and Install".
- e. Install the fuel filter base. Refer to Disassembly and Assembly, "Fuel Filter Base - Remove and Install".
- f. Install the fan drive. Refer to Disassembly and Assembly, "Fan Drive - Install".

i01579693

Lifter Group - Remove and Install**SMCS Code:** 1209-010**Removal Procedure****Start By:**

- a. Remove the fuel filter base. Refer to Disassembly and Assembly, "Fuel Filter Base - Remove and Install".
- b. Remove the rocker arms and pushrods. Refer to Disassembly and Assembly, "Rocker Shaft and Pushrod - Remove".
- c. Remove the unit injector hydraulic pump. Refer to Disassembly and Assembly, "Unit Injector Hydraulic Pump - Remove".
- d. Remove the air compressor. Refer to Disassembly and Assembly, "Air Compressor - Remove and Install".
- e. Remove the engine control module (ECM). Refer to Disassembly and Assembly, "Engine Control Module - Remove and Install".

NOTICE

Keep all parts clean from contaminants.

Contaminants may cause rapid wear and shortened component life.

NOTICE

Care must be taken to ensure that fluids are contained during performance of inspection, maintenance, testing, adjusting and repair of the product. Be prepared to collect the fluid with suitable containers before opening any compartment or disassembling any component containing fluids.

Refer to Special Publication, NENG2500, "Caterpillar Tools and Shop Products Guide" for tools and supplies suitable to collect and contain fluids on Caterpillar products.

Dispose of all fluids according to local regulations and mandates.

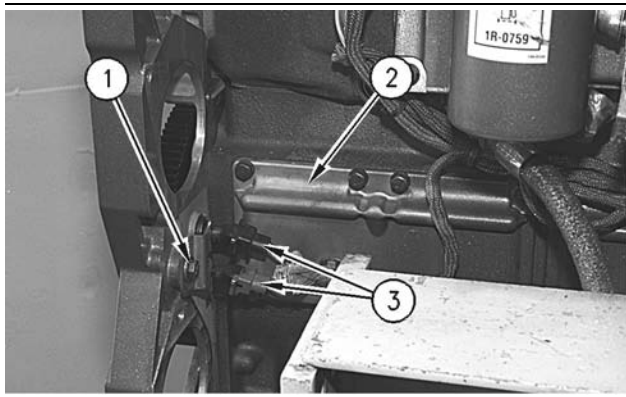

Illustration 194 g00611180

1. Remove bolt (1) that holds the bracket for the engine speed/timing sensor to the timing gear housing. Remove two engine speed/timing sensors (3) and the bracket from the timing gear housing.
2. Cut the straps that hold the wiring harness to side cover (2) of the cylinder block.
3. Remove the bolts that hold side cover (2) to the cylinder block.

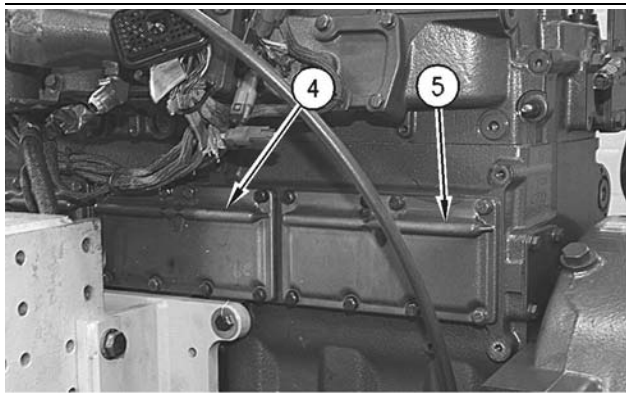

Illustration 195 g00611182

4. Remove the bolts and side covers (4) and (5) from the cylinder block.

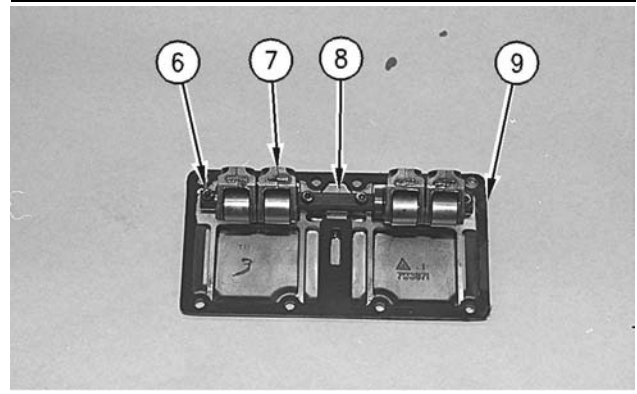

Illustration 196 g00611184

Note: Ensure that the sleeves of the side covers remain in the side covers.

5. Remove four bolts (6) and the dowels that hold the lifter arms (7) and the lifter shaft (8) to each side cover. Remove gasket (9).

Installation Procedure

NOTICE

Keep all parts clean from contaminants.

Contaminants may cause rapid wear and shortened component life.

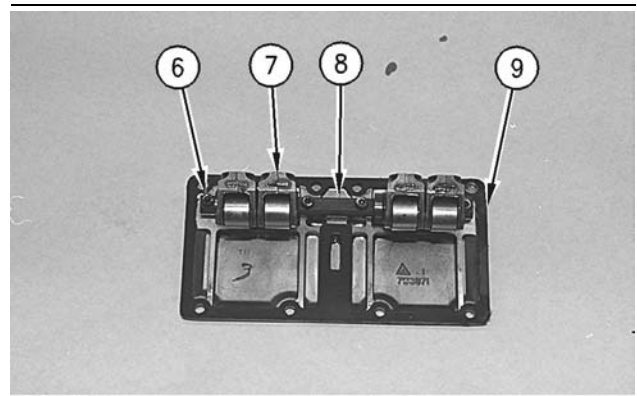

Illustration 197 g00611184

1. Install gasket (9).
2. Install lifter arms (7) on lifter shaft (8).
3. Position lifter shaft (8) and the dowels on the side cover. Ensure that the oil holes in the lifter shaft are facing the side cover. Apply **9S-3263** Thread Lock Compound on the threads of bolts (6) that hold lifter shaft (8) to the side cover. Install bolts (6). Tighten bolts (6) to a torque of 13 ± 3 N·m (10 ± 2 lb ft). Tighten the two center bolts. Then tighten the end bolts.

4. Lubricate the lifters with clean engine oil.

5. Ensure that the cylinder block and the sealing surfaces of the side cover are thoroughly clean. Apply **1U-8846 Sealant** to the sealing surfaces of the side cover. The side covers must be installed on the cylinder block within 10 minutes of applying the sealant.

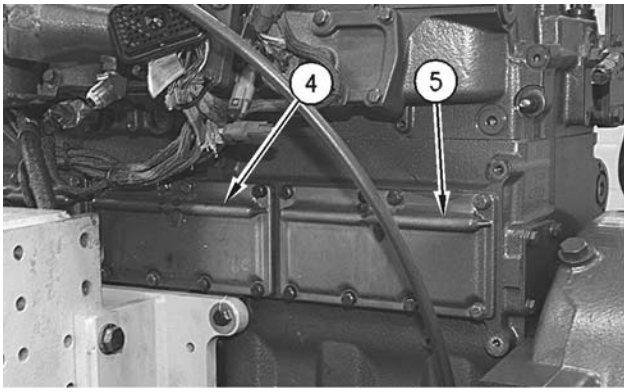

Illustration 198

g00611182

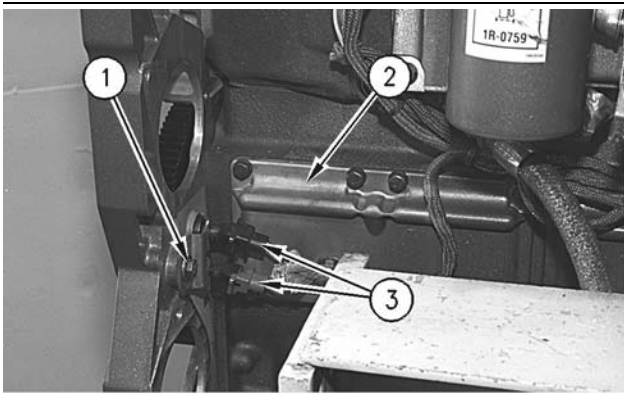

Illustration 199

g00611180

6. Position the gaskets and side covers (2), (4), and (5) on the cylinder block. Install the bolts and clips that hold the side covers in position.
7. Install two engine speed/timing sensors (3) and the bracket to the timing gear housing. Install bolt (1).
8. Secure the two plugs of the wiring harness to the engine speed/timing sensors in the timing gear housing. Use new straps to hold the wiring harness to the side covers of the cylinder block.

End By:

- a. Install the engine control module (ECM). Refer to Disassembly and Assembly, "Engine Control Module - Remove and Install".
- b. Install the air compressor. Refer to Disassembly and Assembly, "Air Compressor - Remove and Install".

- c. Install the unit injector hydraulic pump. Refer to Disassembly and Assembly, "Unit Injector Hydraulic Pump - Install".
- d. Install the rocker arms and pushrods. Refer to Disassembly and Assembly, "Rocker Shaft and Pushrod - Install".
- e. Install the fuel filter base. Refer to Disassembly and Assembly, "Fuel Filter Base - Remove and Install".

i01151060

Camshaft - Remove**SMCS Code:** 1210-011**Removal Procedure****Start By:**

- a. Remove the rocker arms and the push rods. Refer to Disassembly and Assembly, "Rocker Shaft and Pushrod - Remove".
- b. Remove the unit injector hydraulic pump. Refer to Disassembly and Assembly, "Unit Injector Hydraulic Pump - Remove".
- c. Remove the side cover. Refer to Disassembly and Assembly, "Lifter Group - Remove and Install".
- d. Remove the front cover. Refer to Disassembly and Assembly, "Front Cover - Remove".

NOTICE

Keep all parts clean from contaminants.

Contaminants may cause rapid wear and shortened component life.

NOTICE

Care must be taken to ensure that fluids are contained during performance of inspection, maintenance, testing, adjusting and repair of the product. Be prepared to collect the fluid with suitable containers before opening any compartment or disassembling any component containing fluids.

Refer to Special Publication, NENG2500, "Caterpillar Tools and Shop Products Guide" for tools and supplies suitable to collect and contain fluids on Caterpillar products.

Dispose of all fluids according to local regulations and mandates.

Note: The air compressor was removed in order to accommodate the engine repair stand.

1. Turn the crankshaft to top center compression stroke for the No. 1 piston. Install the timing bolt in the flywheel. This is for timing during installation.
2. Ensure that the timing marks on the following gears are aligned: the camshaft drive gear, the idler gear, and the crankshaft gear.

Note: It is not necessary to remove the cylinder head for removal of the camshaft.

3. Wire the valve lifters away from the camshaft.

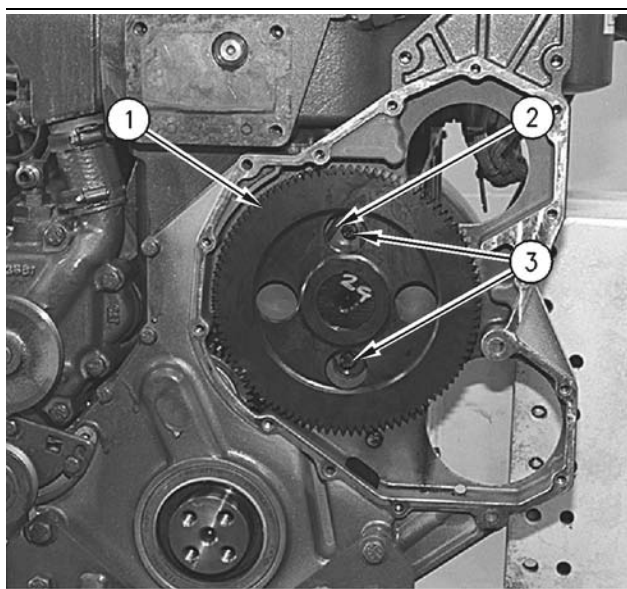

Illustration 200

g00611074

4. Remove two bolts (3) and camshaft retainer plate (2) from camshaft gear (1).

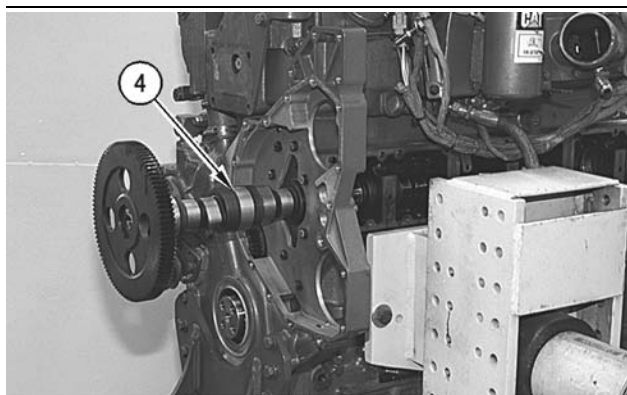

Illustration 201

g00611082

5. Remove camshaft (4) from the cylinder block.

Camshaft - Install

SMCS Code: 1210-012

Installation Procedure

NOTICE

Care must be taken to ensure that fluids are contained during performance of inspection, maintenance, testing, adjusting and repair of the product. Be prepared to collect the fluid with suitable containers before opening any compartment or disassembling any component containing fluids.

Refer to Special Publication, NENG2500, "Caterpillar Tools and Shop Products Guide" for tools and supplies suitable to collect and contain fluids on Caterpillar products.

Dispose of all fluids according to local regulations and mandates.

NOTICE

Keep all parts clean from contaminants.

Contaminants may cause rapid wear and shortened component life.

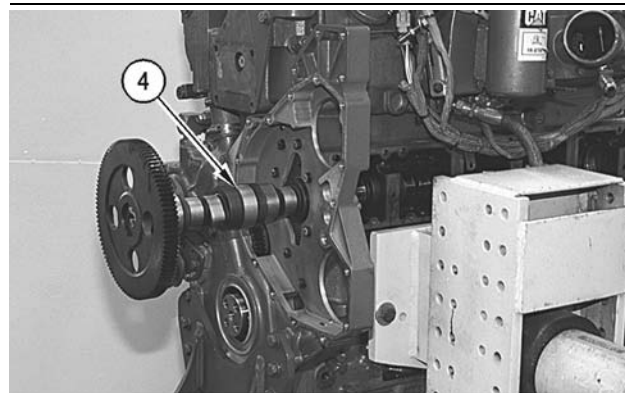

Illustration 202

g00611082

Typical example

Note: The air compressor was removed in order to accommodate the engine repair stand.

1. Carefully install camshaft (4) in the cylinder block.

NOTICE

When installing the camshaft, make sure the number one cylinder is at top center of the compression stroke with the timing bolt installed in the flywheel. The camshaft timing is very important. The timing mark on the camshaft drive gear must line up with the timing mark on the idler gear. Refer to the Specifications Manual for more information.

- Ensure that the timing marks on the following gears are aligned: the camshaft drive gear, the idler gear, and the crankshaft gear.

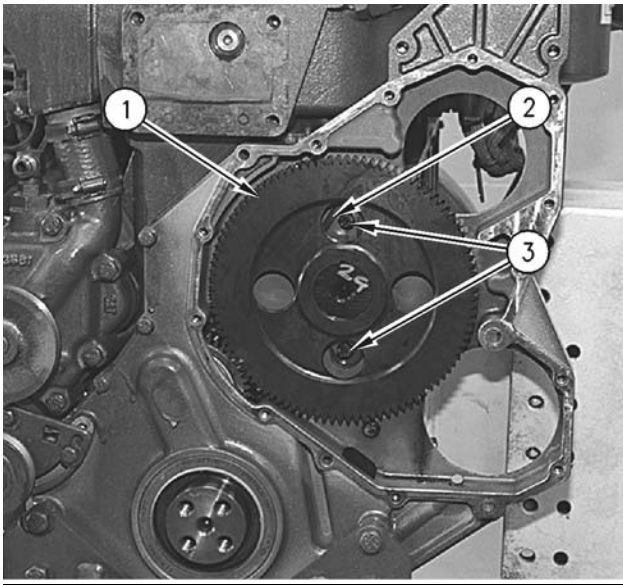

Illustration 203

g00611074

Typical example

- Install camshaft retainer plate (2) and two bolts (3) on camshaft gear (1).

End By:

- Install the front cover. Refer to Disassembly and Assembly, "Front Cover - Install".
- Install the side cover. Refer to Disassembly and Assembly, "Lifter Group - Remove and Install".
- Install the unit injector hydraulic pump. Refer to Disassembly and Assembly, "Unit Injector Hydraulic Pump - Install".
- Install the rocker arms and the pushrods. Refer to Disassembly and Assembly, "Rocker Shaft and Pushrod - Install".

i01151709

Camshaft Gear - Remove and Install

SMCS Code: 1210-010-GE

Removal Procedure

Start By:

- Remove the camshaft. Refer to Disassembly and Assembly, "Camshaft - Remove".

- Wrap the camshaft with a protective covering in order to prevent damage to the camshaft.

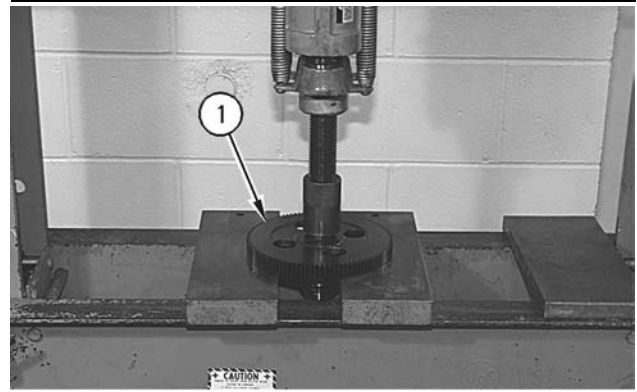

Illustration 204

g00611152

NOTICE

Do not allow the camshaft to fall to the floor when pressing it from the drive gear. Also make sure that the camshaft lobes do not catch on the press plates.

- Place the camshaft and camshaft gear (1) in a suitable press. Press the camshaft from camshaft gear (1).

Installation Procedure

- Heat the camshaft gear to a maximum temperature of 315 °C (600 °F).
- Align the key in the camshaft with the groove (keyway) in the camshaft gear.
- Install the camshaft gear on the end of the camshaft.

End By:

- Install the camshaft. Refer to Disassembly and Assembly, "Camshaft - Install".

i01747789

Engine Oil Pan - Remove and Install

SMCS Code: 1302-010

Removal Procedure

WARNING

Hot oil and components can cause personal injury.

Do not allow hot oil or components to contact skin.

NOTICE

Keep all parts clean from contaminants.

Contaminants may cause rapid wear and shortened component life.

NOTICE

Care must be taken to ensure that fluids are contained during performance of inspection, maintenance, testing, adjusting and repair of the product. Be prepared to collect the fluid with suitable containers before opening any compartment or disassembling any component containing fluids.

Refer to Special Publication, NENG2500, "Caterpillar Tools and Shop Products Guide" for tools and supplies suitable to collect and contain fluids on Caterpillar products.

Dispose of all fluids according to local regulations and mandates.

1. Drain the engine oil into a suitable container for storage or disposal.

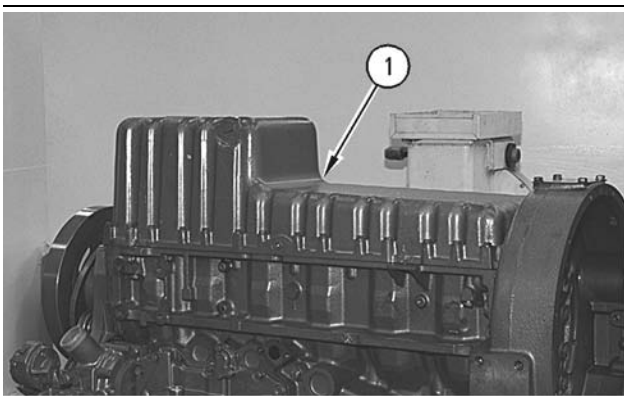

Illustration 205

g00610543

Typical example

Note: Do not pry or gouge the sealing surface of the engine oil pan. Use a rubber mallet to tap lightly on the engine oil pan, if it is necessary.

2. Remove the bolts for the engine oil pan. Remove engine oil pan (1).

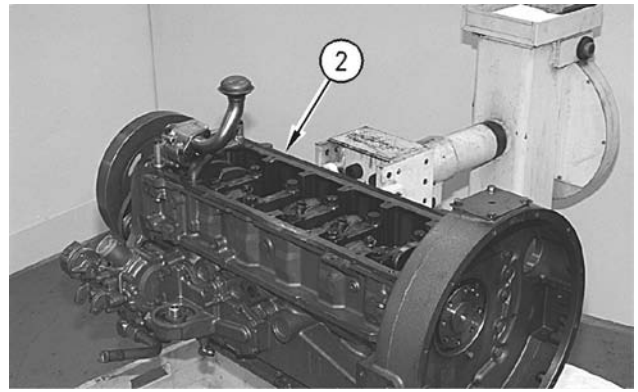

Illustration 206

g00610550

Typical example

3. Remove gasket (2) from the engine oil pan.
4. Remove the drain plug and the O-ring seal from the engine oil pan.

Installation Procedure

NOTICE

Keep all parts clean from contaminants.

Contaminants may cause rapid wear and shortened component life.

1. Install the drain plug and the O-ring seal on the engine oil pan. Tighten the drain plug to $25 \pm 5 \text{ N}\cdot\text{m}$ ($18 \pm 4 \text{ lb ft}$).
2. Inspect the condition of the gasket. Replace the gasket, if necessary.
3. Clean the mating surface of the engine oil pan and the cylinder block.

Note: Do not put liquid gasket material on the oil pan gasket or on the gasket surface of the engine oil pan.

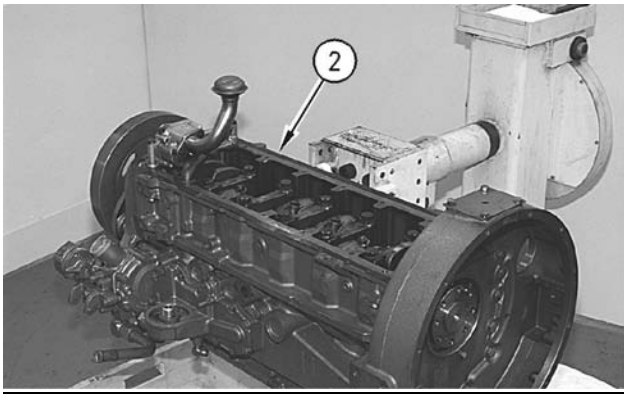

Illustration 207

g00610550

Typical example

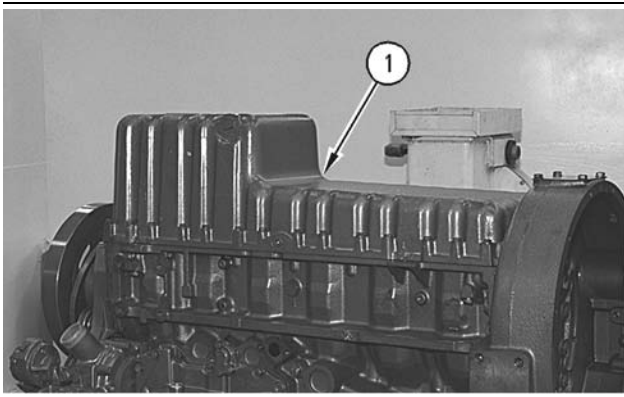

Illustration 208

g00610543

Typical example

4. Place new gasket (2) and engine oil pan (1) on the cylinder block.

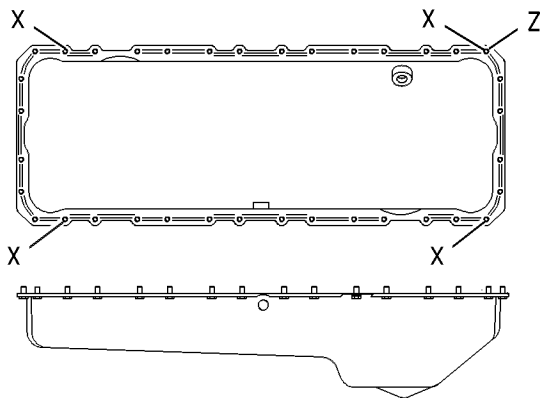

Illustration 209

g00610574

5. Install the bolts for the engine oil pan. Tighten the Bolts (X). Tighten the bolts to a torque of $31 \pm 3 \text{ N}\cdot\text{m}$ ($23 \pm 2 \text{ lb ft}$).
6. Start at Position (Z) and tighten the remaining bolts in a counterclockwise direction. Tighten the remaining bolts to a torque of $31 \pm 3 \text{ N}\cdot\text{m}$ ($23 \pm 2 \text{ lb ft}$).
7. Start at Position (Z) and tighten the bolts again in a counterclockwise direction. Tighten the bolts to a torque of $31 \pm 3 \text{ N}\cdot\text{m}$ ($23 \pm 2 \text{ lb ft}$).
8. Fill the engine with oil to the correct level. Refer to the Operation and Maintenance Manual for the correct filling procedure.

i01150877

Piston Cooling Jets - Remove and Install

SMCS Code: 1331-010

Removal Procedure

Start By:

- a. Remove the engine oil pump. Refer to Disassembly and Assembly, "Engine Oil Pump - Remove".

NOTICE

Keep all parts clean from contaminants.

Contaminants may cause rapid wear and shortened component life.

NOTICE

Care must be taken to ensure that fluids are contained during performance of inspection, maintenance, testing, adjusting and repair of the product. Be prepared to collect the fluid with suitable containers before opening any compartment or disassembling any component containing fluids.

Refer to Special Publication, NENG2500, "Caterpillar Tools and Shop Products Guide" for tools and supplies suitable to collect and contain fluids on Caterpillar products.

Dispose of all fluids according to local regulations and mandates.

i01287371

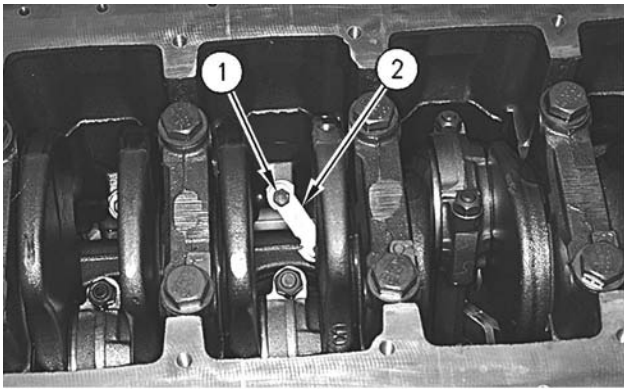

Illustration 210

g00610526

1. Remove bolt (1) and piston cooling jet (2) from each cylinder.

Installation Procedure

NOTICE

Keep all parts clean from contaminants.

Contaminants may cause rapid wear and shortened component life.

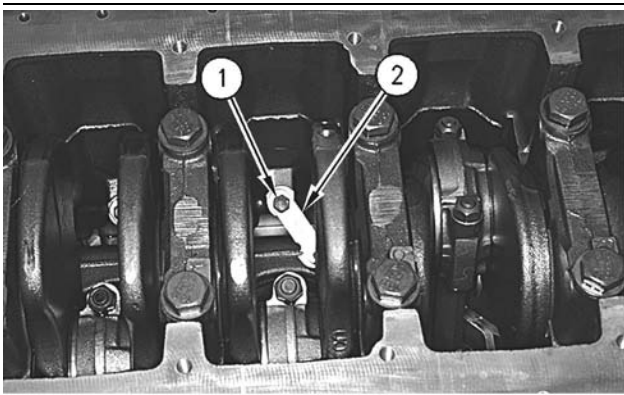

Illustration 211

g00610526

1. Position piston cooling jet (2) in the cylinder block. Ensure that piston cooling jet (2) is seated properly. Hold piston cooling jet (2) and install bolt (1) in each cylinder. Tighten the bolt to a torque of 28 ± 7 N·m (21 ± 5 lb ft).

End By:

- a. Install the engine oil pump. Refer to Disassembly and Assembly, "Engine Oil Pump - Install".

Pistons and Connecting Rods - Remove

SMCS Code: 1225-011

Removal Procedure

Start By:

- a. Remove the cylinder head. Refer to Disassembly and Assembly, "Cylinder Head - Remove".
- b. Remove the engine oil pump. Refer to Disassembly and Assembly, "Engine Oil Pump - Remove".
- c. Remove the piston cooling jets. Refer to Disassembly and Assembly, "Piston Cooling Jets - Remove and Install".

NOTICE

Keep all parts clean from contaminants.

Contaminants may cause rapid wear and shortened component life.

Note: For information on reusability of the pistons, refer to the following list.

- Guideline For Reusable Parts And Salvage Operations, SEBF8049, "Pistons"
- Guideline For Reusable Parts And Salvage Operations, SEBF8290, "Visual Inspection of Two-Piece Pistons"
- Tool Operating Manual, NEHS0775, "Using the 186-0137 Piston Ring Gauge on Steel Crown, Two-Piece Pistons used in 3126 and 3126B Engines"

Note: For information on reusability of the connecting rods, refer to the following list.

- Guideline For Reusable Parts And Salvage Operations, SEBF8063, "Visual Inspection of Connecting Rods"
- Guideline For Reusable Parts And Salvage Operations, SEBF8064, "Salvage of Non-Serrated Connecting Rods"

Note: For information on reusability of the piston pins, refer to the following list.

- Guideline For Reusable Parts And Salvage Operations, SEBF8051, "Piston Pins and Retaining Rings"

Truck Engine Disassembly and Assembly Section

- Guideline For Reusable Parts And Salvage Operations, SEBF8303, "Procedure to Inspect Piston Pins"

Note: For information on reusability of the rod eye bushing, refer to the following list.

- Guideline For Reusable Parts And Salvage Operations, SEBF8242, "Verification of Connecting Rod Eye Bushing Retention Using 5P-8639 Connecting Rod Bushing Press Group"
- Guideline For Reusable Parts And Salvage Operations, SEBF8274, "Using Rod Eye Bushing Installation and Removal Tools"

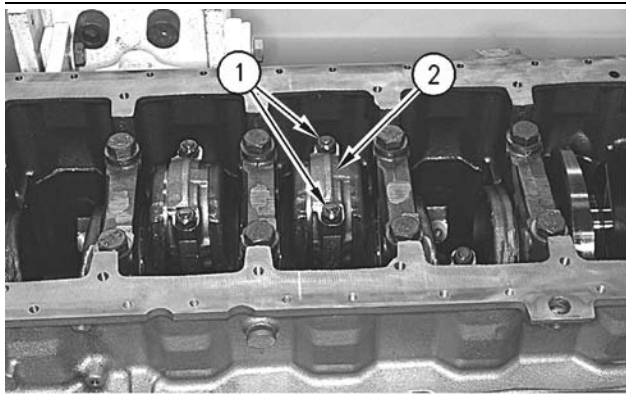

Illustration 212

g00610269

- Inspect the connecting rod and connecting rod cap (2) for the proper identification mark. The connecting rod and connecting rod cap (2) should have an etched number on the side that is toward the right side of the engine. The number should match the cylinder number. Mark the connecting rod and connecting rod cap (2), if necessary.
- Remove connecting rod cap nuts (1), bolts (5), and connecting rod cap (2).

NOTICE

Install short pieces of rubber hose over both connecting rod bolts in order to protect the crankshaft from the threaded portion of the connecting rod bolts.

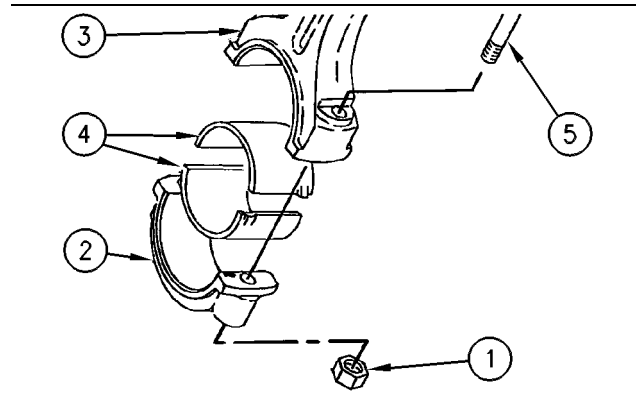

Illustration 213

g00610272

- Remove the lower half of bearing (4) from connecting rod cap (2).
- Push the piston and connecting rod away from the crankshaft. Remove the upper half of connecting rod bearing (4) from connecting rod (3).
- Remove the piston and connecting rod (3) from the cylinder block.
- Repeat Steps 1 through 5 for the remaining pistons and connecting rods.

i01336888

Pistons and Connecting Rods - Disassemble

SMCS Code: 1225-015

Disassembly Procedure

Table 39

Required Tools			
Tool	Part Number	Part Description	Qty
A	1U-6683	Piston Ring Expander	1
B	1P-1861	Retaining Ring Pliers	1

Start By:

- Remove the pistons and the connecting rods. Refer to Disassembly and Assembly, "Pistons and Connecting Rods - Remove".

NOTICE

Keep all parts clean from contaminants.

Contaminants may cause rapid wear and shortened component life.

Note: For information on reusability of the pistons, refer to the following list.

- Guideline For Reusable Parts And Salvage Operations, SEBF8049, "Pistons"
- Guideline For Reusable Parts And Salvage Operations, SEBF8290, "Visual Inspection of Two-Piece Pistons"
- Tool Operating Manual, NEHS0775, "Using the 186-0137 Piston Ring Gauge on Steel Crown, Two-Piece Pistons used in 3126 Engines"

Note: For information on reusability of the connecting rods, refer to the following list.

- Guideline For Reusable Parts And Salvage Operations, SEBF8063, "Visual Inspection of Connecting Rods"
- Guideline For Reusable Parts And Salvage Operations, SEBF8064, "Salvage of Non-Serrated Connecting Rods"

Note: For information on reusability of the piston pins, refer to the following list.

- Guideline For Reusable Parts And Salvage Operations, SEBF8051, "Piston Pins and Retaining Rings"
- Guideline For Reusable Parts And Salvage Operations, SEBF8303, "Procedure to Inspect Piston Pins"

Note: For information on reusability of the rod eye bushing, refer to the following list.

- Guideline For Reusable Parts And Salvage Operations, SEBF8242, "Verification of Connecting Rod Eye Bushing Retention Using 5P-8639 Connecting Rod Bushing Press Group"
- Guideline For Reusable Parts And Salvage Operations, SEBF8274, "Using Rod Eye Bushing Installation and Removal Tools"

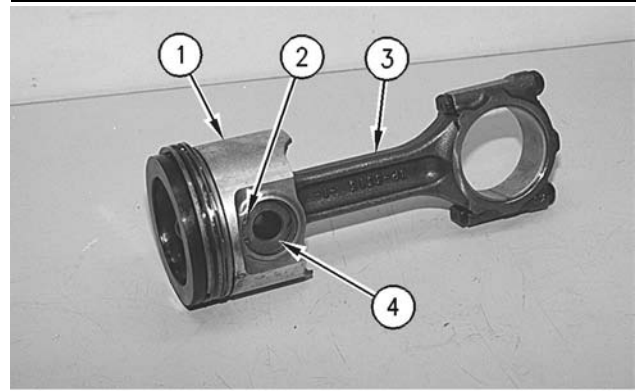

Illustration 214

g00610426

1. Use Tool (B) to remove retaining ring (2). Remove piston pin (4) and separate piston (1) from connecting rod (3).

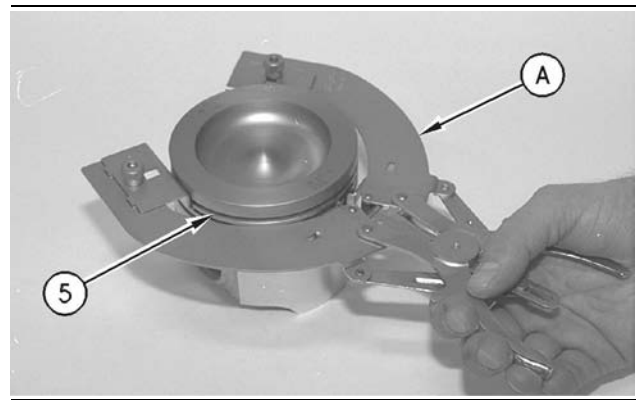

Illustration 215

g00610428

2. Use Tool (A) to remove piston ring (5).

i01337585

Pistons and Connecting Rods - Assemble

SMCS Code: 1225-016

Assembly Procedure

Table 40

Required Tools			
Tool	Part Number	Part Description	Qty
A	1U-6683	Ring Expander	1

NOTICE

Keep all parts clean from contaminants.

Contaminants may cause rapid wear and shortened component life.

NOTICE

Verify correct assembly of the pistons and the connecting rods. Ensure that the etched numbers on the rod and the rod cap are in the correct positions. The etched number on the rod and the rod cap correspond to the cylinder in which it should be installed.

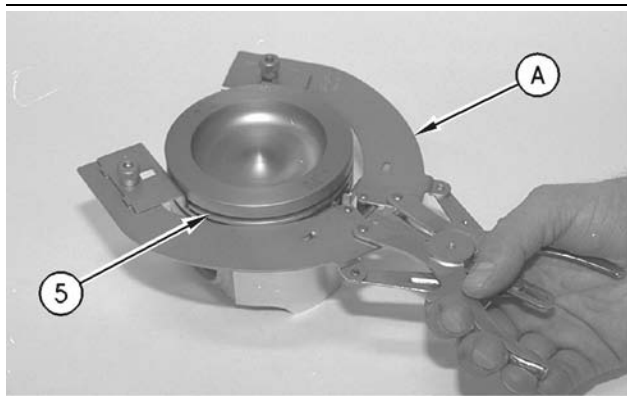

Illustration 216

g00610428

1. Check the clearance between the ends of piston rings (5). Refer to the Specifications Manual, "Pistons and Rings" topic.

Note: The oil ring must be installed over the spring with the end gap 180 degrees from the oil ring spring joint.

2. Install the oil control piston ring with Tool (A). The ends of the spring should be rotated 180 degrees from the ring end gap.
3. Install the intermediate piston ring with the side marked "UP-2" toward the top of the piston. Use Tool (A) in order to install the ring.
4. Install the top piston ring with the side marked "UP-1" toward the top of the piston. Use Tool (A) in order to install the ring.

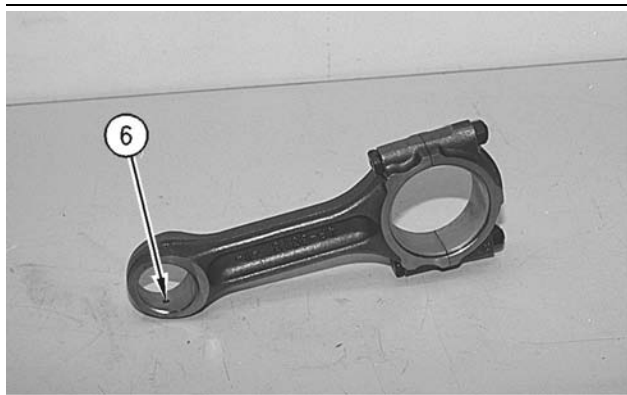

Illustration 217

g00610498

5. Replace rod bearing (6) by pressing a new bearing into the connecting rod. Refer to Special Instruction, SEHS7295 for the correct tooling and the correct installation procedure.

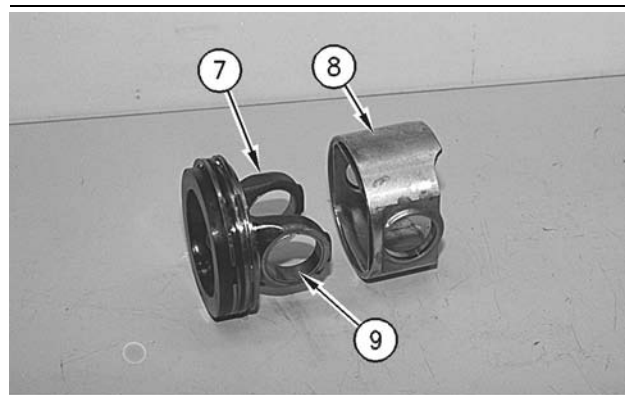

Illustration 218

g00610503

6. The piston is a two-piece assembly. This piston consists of piston crown (7) and piston skirt (8). Inspect bearing (9) in the piston crown (7). The piston crown must be replaced if the piston crown is worn or damaged. Bearing (9) is not serviced.

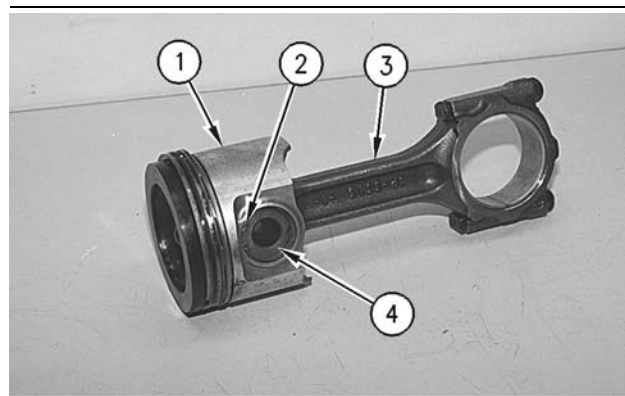

Illustration 219

g00610426

NOTICE

An improperly installed retainer ring could cause the piston and connecting rod to come apart during engine operation. This action can result in a broken Piston Skirt and major engine damage.

7. Position piston (1) on connecting rod (3). Coat pin (4) with clean engine oil and install pin (4). Ensure that the retainer rings are in the grooves of piston (1).

End By:

- a. Install the pistons and the connecting rods. Refer to Disassembly and Assembly, "Piston and Connecting Rods - Install".

i01459773

Pistons and Connecting Rods - Install

SMCS Code: 1225-012

Installation Procedure

Table 41

Required Tools			
Tool	Part Number	Part Description	Qty
A	173-5529	Piston Ring Compressor	1

NOTICE

Keep all parts clean from contaminants.

Contaminants may cause rapid wear and shortened component life.

Note: For information on reusability of the pistons, refer to the following list.

- Guideline For Reusable Parts And Salvage Operations, SEBF8049, "Pistons"
- Guideline For Reusable Parts And Salvage Operations, SEBF8290, "Visual Inspection of Two-Piece Pistons"
- Tool Operating Manual, NEHS0775, "Using the 186-0190 Piston Ring Gauge on Steel Crown, Two-Piece Pistons used in 3126 and 3126B Engines"

Note: For information on reusability of the connecting rods, refer to the following list.

- Guideline For Reusable Parts And Salvage Operations, SEBF8063, "Visual Inspection of Connecting Rods"
- Guideline For Reusable Parts And Salvage Operations, SEBF8064, "Salvage of Non-Serrated Connecting Rods"

Note: For information on reusability of the piston pins, refer to the following list.

- Guideline For Reusable Parts And Salvage Operations, SEBF8051, "Piston Pins and Retaining Rings"
- Guideline For Reusable Parts And Salvage Operations, SEBF8303, "Procedure to Inspect Piston Pins"

Note: For information on reusability of the rod eye bushing, refer to the following list.

- Guideline For Reusable Parts And Salvage Operations, SEBF8242, "Verification of Connecting Rod Eye Bushing Retention Using 5P-8639 Connecting Rod Bushing Press Group"
- Guideline For Reusable Parts And Salvage Operations, SEBF8274, "Using Rod Eye Bushing Installation and Removal Tools"

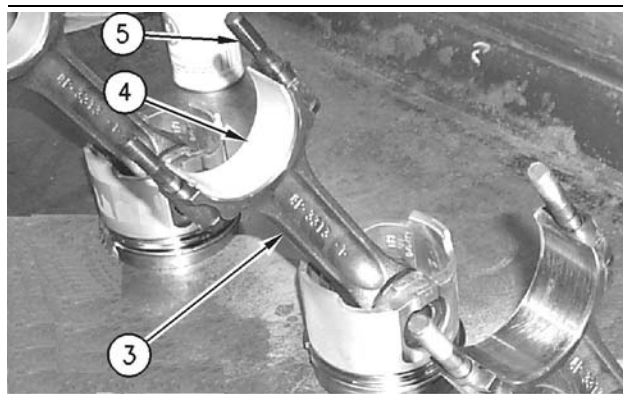

Illustration 220

g00678193

1. Install the bolts (5) and the upper half of connecting rod bearing (4). Ensure that the bearing tab engages with the slot in connecting rod (3).

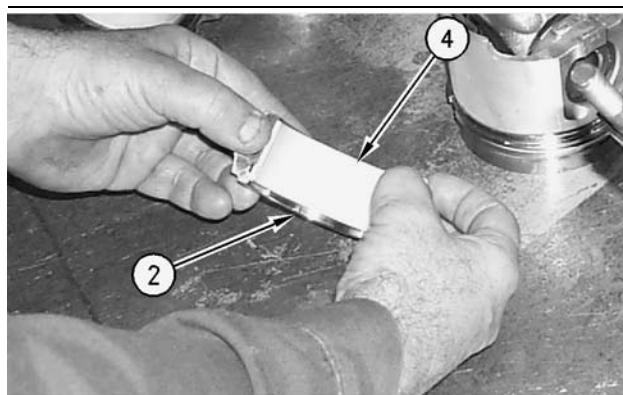

Illustration 221

g00678195

2. Install the lower half of connecting rod bearing (4). Ensure that the bearing tab engages with the slot in connecting rod cap (2).
3. Place clean engine oil on the following items: the pistons, the piston rings, the cylinder bore, the upper half of the connecting rod bearing, and the lower half of the connecting rod bearing.

NOTICE

Install short pieces of rubber hose over both connecting rod bolts in order to protect the crankshaft from the threaded portion of the connecting rod bolts.



Illustration 222

g00746584

4. Install short pieces of rubber hose (6) over both connecting rod bolts.

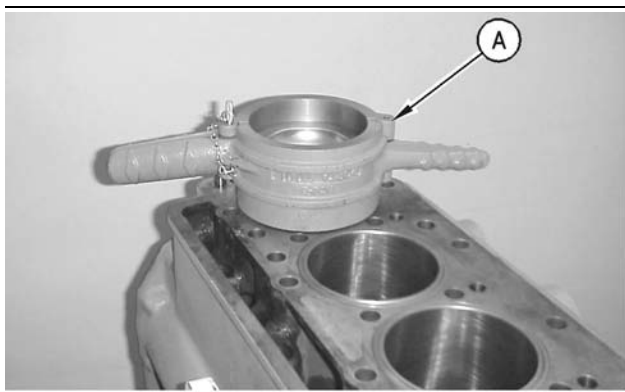

Illustration 223

g00634923

Note: Each piston ring end gap must be positioned 120 degrees from each other.

5. Install Tool (A) in order to compress the piston rings.
 6. With the number one crankshaft throw at the bottom center, install the piston and connecting rod in the engine. Ensure that the proper piston and connecting rod are in the corresponding cylinder with the bearing retainer notch toward the right side of the engine.
- Note:** The etched number on the connecting rod must be on the right side of the engine in the corresponding cylinder.
7. Line up the piston and the connecting rod with the crankshaft. Use a soft hammer and tap the piston into the cylinder bore until Tool (A) comes off of the piston.
 8. Use a soft hammer in order to tap the piston into the cylinder bore while you guide connecting rod (3) onto the crankshaft.

9. Remove the hoses that were installed in Step 4 from the connecting rod bolts.

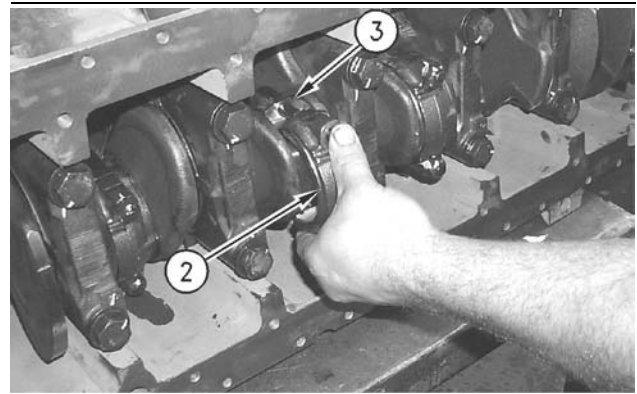

Illustration 224

g00678200

10. Install connecting rod bearing cap (2) on the connecting rod (3). Ensure that the number on connecting rod bearing cap (2) matches the number on the connecting rod (3). Ensure that the numbers are on the same side.

11. Lubricate connecting rod cap bolts with 4C-5593 Anti-Seize Compound.

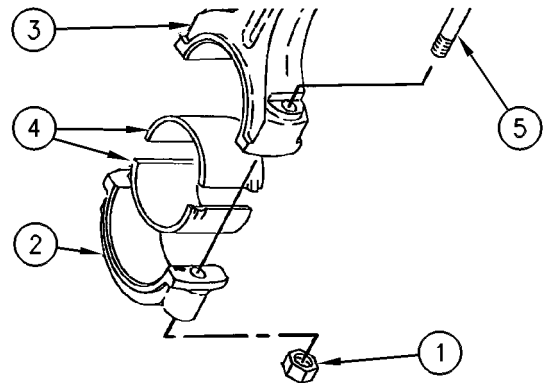

Illustration 225

g00610272

NOTICE

Loose connecting rod nuts can result in the separation of the rod cap and result in major engine damage.

12. Install connecting rod cap nuts (1). Tighten nuts (1) to a torque of 54 ± 7 N·m (40 ± 5 lb ft).

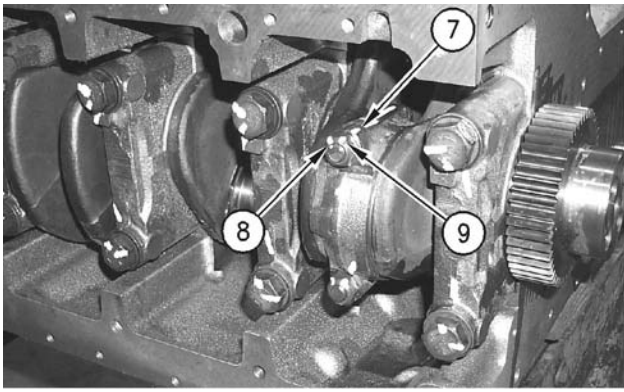

Illustration 226

g00678202

13. Place index mark (7) on the connecting rod. Place index mark (9) on connecting rod cap nut (1). Index marks (7) and (9) mark the initial position of the nut. Place index mark (8) on connecting rod cap nut (1). Index mark (8) should be 60 ± 5 degrees counterclockwise from index mark (9). Tighten each nut (1) for an additional 60 ± 5 degrees (1/6 turn). Index mark (8) should be lined up with index mark (7). Repeat the procedure for the other connecting rod cap nut.

14. Repeat Steps 1 through 13 for the remaining pistons and connecting rods.

End By:

- a. Install the piston cooling jets. Refer to Disassembly and Assembly, "Piston Cooling Jets - Remove and Install".
- b. Install the engine oil pump. Refer to Disassembly and Assembly, "Engine Oil Pump - Install".
- c. Install the cylinder head. Refer to Disassembly and Assembly, "Cylinder Head - Install".

i01747897

Crankshaft Main Bearings - Remove

SMCS Code: 1203-011

Removal Procedure

Table 42

Required Tools			
Tool	Part Number	Part Description	Qty
A	2P-5518	Bearing Tool	1

Start By:

- a. Remove the engine oil pump. Refer to Disassembly and Assembly, "Engine Oil Pump - Remove".

NOTICE

Keep all parts clean from contaminants.

Contaminants may cause rapid wear and shortened component life.

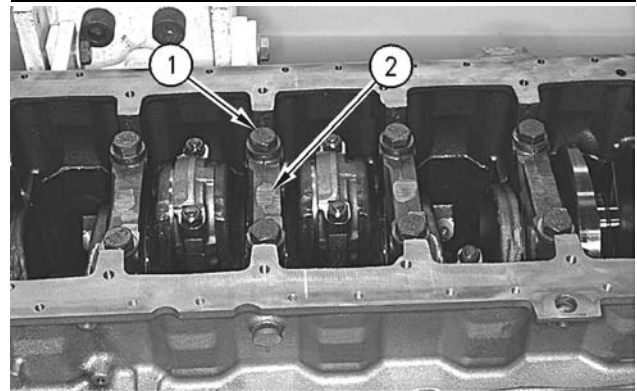

Illustration 227

g00610152

- 1. Remove bolts (1) that hold crankshaft main bearing cap (2). Remove crankshaft main bearing cap (2).
- 2. Remove the lower half of the crankshaft main bearing from crankshaft main bearing cap (2).

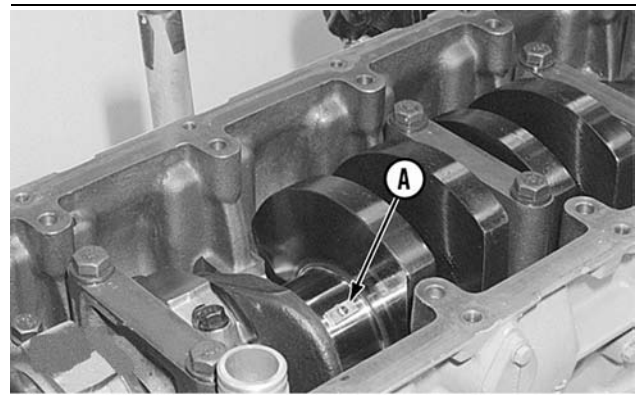

Illustration 228

g00516920

Typical example

NOTICE

If the crankshaft is turned in the wrong direction, the tab of the crankshaft main bearing will be pushed between the crankshaft and the cylinder block. This can cause damage to either or both the crankshaft and the cylinder block.

- 3. Use the following steps in order to remove the upper half of crankshaft main bearings:

- a. Turn the crankshaft until Tooling (A) can be installed in the crankshaft journal. Install Tooling (A).
- b. Turn the crankshaft in order to remove the upper half of the crankshaft main bearing. In order to get the tab out first, the crankshaft must be turned in the correct direction.
- c. Check the condition of the crankshaft main bearings. Refer to the Guideline For Reusable Parts, SEBF8009, "Main and Connecting Rod Bearings" or refer to the Guideline For Reusable Parts, SEBV0544, "Engine Bearings and Crankshafts".

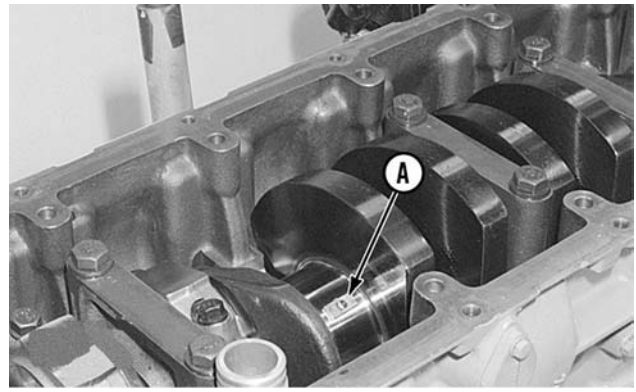

Illustration 229

g00516920

Crankshaft Main Bearings - Install

SMCS Code: 1203-012

Installation Procedure

Table 43

Required Tools			
Tool	Part Number	Part Description	Qty
A	2P-5518	Main Bearing Tool	1
B	8T-5096	Dial Indicator Group	1

NOTICE

Keep all parts clean from contaminants.

Contaminants may cause rapid wear and shortened component life.

Note: Place clean engine oil on the crankshaft main bearings prior to assembly. Ensure that the tabs on the back side of the crankshaft main bearings fit in the grooves of the crankshaft main bearing caps and the cylinder block.

1. Use Tooling (A) and install the upper halves of the crankshaft main bearings in the cylinder block. Do not put oil on the back of the crankshaft main bearing.

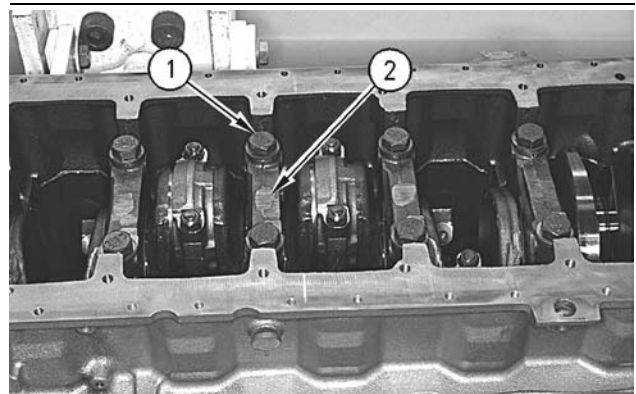

Illustration 230

g00610152

2. Install the lower halves of the crankshaft main bearings in crankshaft main bearing caps (2). Do not put oil on the back of the crankshaft main bearing.

NOTICE

Crankshaft main bearing caps should be installed with the part number toward the right side of the engine. Crankshaft main bearing caps are to be identified by stamped numbers 1 through 7 located on the bottom surface. The thrust plate is used on the number 6 crankshaft main bearing only.

3. Place crankshaft main bearing caps (2) in position on the cylinder block. Place clean engine oil or Molyube on the bolt threads and on the washer face. Install bolts (1).
4. Tighten bolts (1) to a torque of 54 ± 7 N·m (40 ± 5 lb ft). Tighten each bolt (1) for an additional 90 ± 5 degrees ($1/4$ turn).

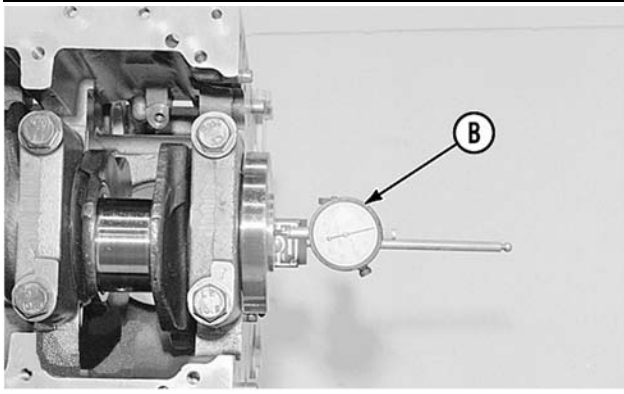

Illustration 231

g00517003

5. Check the end play of the crankshaft with Tooling (B). The end play must be 0.07 mm (0.003 inch) to 0.32 mm (0.013 inch).

End By:

- a. Install the engine oil pump. Refer to Disassembly and Assembly, "Engine Oil Pump - Install".

i01197475

Crankshaft - Remove

SMCS Code: 1202-011

Removal Procedure

Start By:

- a. Remove the cylinder head. Refer to Disassembly and Assembly, "Cylinder Head - Remove".
- b. Remove the front housing. Refer to Disassembly and Assembly, "Housing (Front) - Remove".
- c. Remove the camshaft idler gear. Refer to Disassembly and Assembly, "Camshaft Idler Gear - Remove and Install".
- d. Remove the pistons and connecting rods. Refer to Disassembly and Assembly, "Pistons and Connecting Rods - Remove".

NOTICE

Keep all parts clean from contaminants.

Contaminants may cause rapid wear and shortened component life.

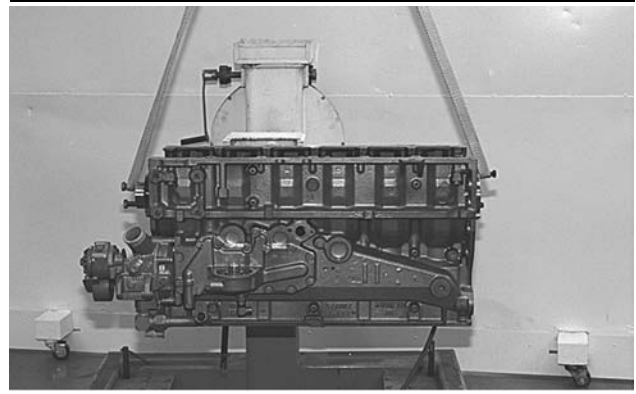

Illustration 232

g00609979

1. Fasten lifting slings and a hoist to each end of the crankshaft. Refer to Illustration 232.

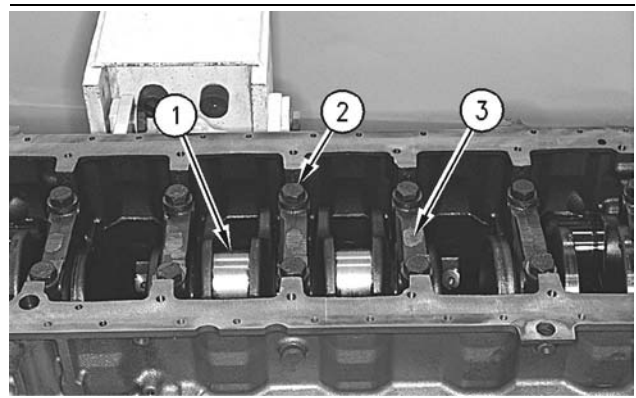

Illustration 233

g00609985

2. Remove bolts (2), the washers, and main bearing caps (3). Carefully remove crankshaft (1) from the cylinder block. The weight of the crankshaft is approximately 62 kg (137 lb).
3. Remove the main bearings from the cylinder block. Remove the main bearings from the main bearing caps.

i01747936

Crankshaft - Install

SMCS Code: 1202-012

Installation Procedure

Table 44

Required Tools			
Tool	Part Number	Part Description	Qty
A	8T-5096	Dial Indicator Group	1

NOTICE

Keep all parts clean from contaminants.

Contaminants may cause rapid wear and shortened component life.

NOTICE

Ensure that the crankshaft main bearing tabs engage with the grooves in the block and the crankshaft main bearing cap.

1. Check the condition of the main bearings. Refer to Guideline For Reusable Parts, SEBF8009, "Main and Connecting Rod Bearings" or refer to Guideline For Reusable Parts, SEBV0544, "Engine Bearings and Crankshafts".

Note: The number six main bearing is the thrust bearing.

2. Clean the bearing surfaces in the cylinder block for the main bearings. Apply clean engine oil on the upper main bearing. Do not put engine oil on the back side of the bearing surfaces. Install the upper main bearing in the cylinder block. Ensure that the tab on the back side of the bearing engages with the groove in the cylinder block.

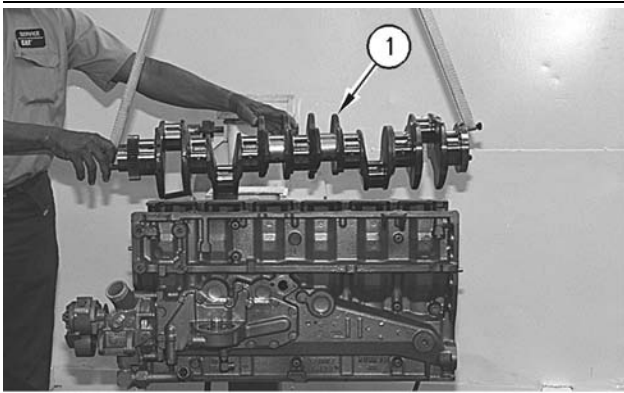

Illustration 234

g00610100

3. Put clean engine oil on the journals of the crankshaft bearing. Fasten lifting straps and a hoist to crankshaft (1). Carefully install the crankshaft in the cylinder block.
4. Clean the bearing surface of the main bearing caps. Install the lower main bearing in the crankshaft main bearing caps. Ensure that the tab on the back side of the bearing engages with the groove in the main bearing cap. Apply clean engine oil on the lower main bearing. Do not put engine oil on the back side of the bearing surfaces.

5. Install crankshaft main bearing caps with the part numbers toward the right hand side of the cylinder block. Ensure that crankshaft main bearing caps have numbers 1 through 7. The numbers should start at the front of the engine. Place clean engine oil or Molylube on the bolt threads and the washers.

Note: When the bolts for the rear main bearing cap are tightened, slide the main bearing cap as far forward as possible until the cap is against the bolts. Hold the main bearing cap in this position and tighten the bolts.

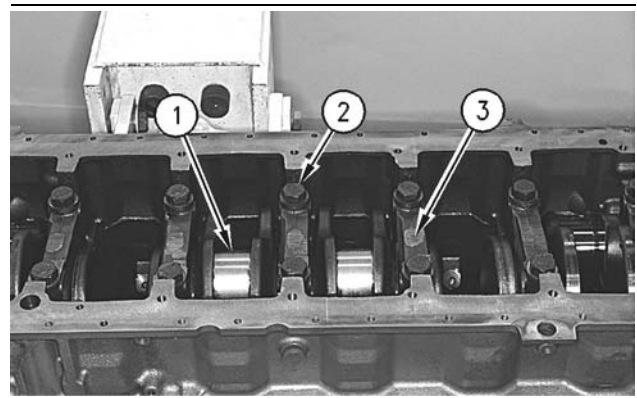

Illustration 235

g00609985

6. Install bolts (2) and the washers for main bearing caps (3). Tighten bolts (2) to a torque of 54 ± 7 N·m (40 ± 5 lb ft).
7. Turn bolts (2) for an additional 90 ± 5 degrees ($1/4$ turn).

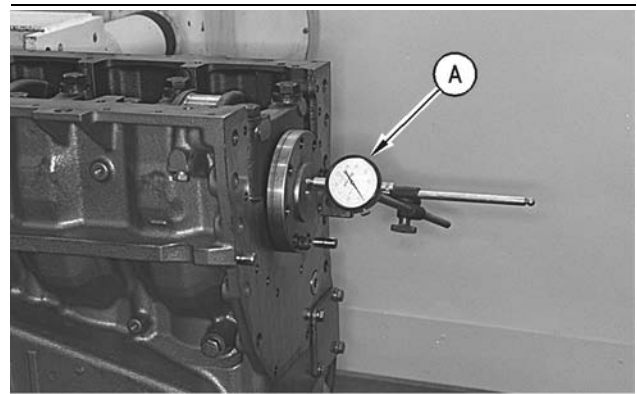

Illustration 236

g00610119

8. Check the end play of crankshaft (1) with Tooling (A). The end play must be 0.07 mm (0.003 inch) to 0.32 mm (0.013 inch).

End By:

- a. Install the pistons and connecting rods. Refer to Disassembly and Assembly, "Pistons and Connecting Rods - Install".
- b. Install the camshaft idler gear. Refer to Disassembly and Assembly, "Camshaft Idler Gear - Remove and Install".
- c. Install the front housing. Refer to Disassembly and Assembly, "Housing (Front) - Install".
- d. Install the cylinder head. Refer to Disassembly and Assembly, "Cylinder Head - Install".

i01747939

Crankshaft Gear - Remove and Install

SMCS Code: 1204-010-GE

Removal Procedure

Table 45

Required Tools			
Tool	Part Number	Part Description	Qty
A	8B-7551	Bearing Puller	1
	8B-7549	Puller Leg	2
	3H-0465	Push-Puller Plate	4
	6B-6682	Full Nut	2
	8B-7560	Step Plate	1
	1P-0820	Hydraulic Puller	1
	9U-6600	Hand Hydraulic Pump	1

Start By:

- a. Remove the crankshaft. Refer to Disassembly and Assembly, "Crankshaft - Remove".

NOTICE

Keep all parts clean from contaminants.

Contaminants may cause rapid wear and shortened component life.

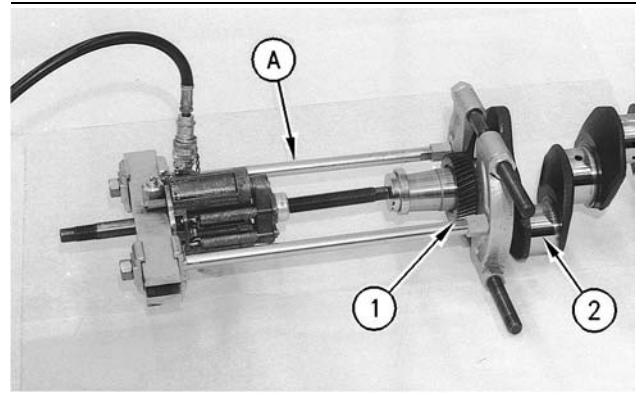

Illustration 237

g00645876

- 1. Use Tooling (A) in order to remove crankshaft gear (1) from crankshaft (2).

Installation Procedure

NOTICE

Keep all parts clean from contaminants.

Contaminants may cause rapid wear and shortened component life.

- 1. Position the woodruff key in the crankshaft.

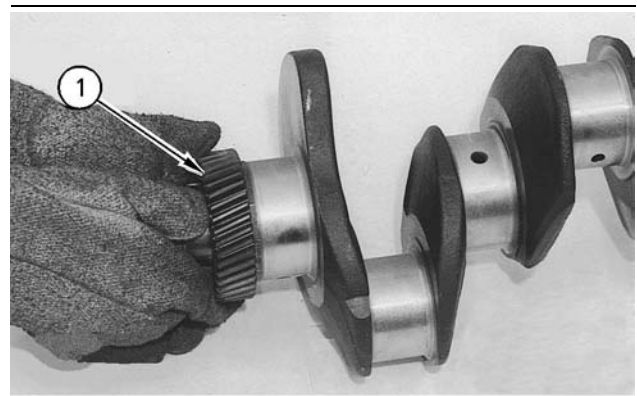

Illustration 238

g00645882

WARNING

Hot oil and hot components can cause personal injury. Do not allow hot oil or hot components to contact the skin.

- 2. Heat crankshaft gear (1) to a maximum temperature of 316 °C (600 °F). Install crankshaft gear (1) on the crankshaft.

End By:

- a. Install the crankshaft. Refer to Disassembly and Assembly, "Crankshaft - Install".

i01738512

Bearing Clearance - Check

SMCS Code: 1203-535; 1219-535

Measurement Procedure

Table 46

Required Tools			
Tool	Part Number	Part Description	Qty
A	198-9142	Plastic Gauge	1
	198-9143	Plastic Gauge	1
	198-9144	Plastic Gauge	1
	198-9145	Plastic Gauge	1

NOTICE

Keep all parts clean from contaminants.

Contaminants may cause rapid wear and shortened component life.

Note: Caterpillar does not recommend the checking of the actual bearing clearances particularly on small engines. This is because of the possibility of obtaining inaccurate results and the possibility of damaging the bearing or the journal surfaces. Each Caterpillar engine bearing is quality checked for specific wall thickness.

Note: The measurements should be within specifications and the correct bearings should be used. If the crankshaft journals and the bores for the block and the rods were measured during disassembly, no further checks are necessary. However, if the technician still wants to measure the bearing clearances, Tooling (A) is an acceptable method. Tooling (A) is less accurate on journals with small diameters if clearances are less than 0.10 mm (0.004 inch).

NOTICE

Lead wire, shim stock or a dial bore gauge can damage the bearing surfaces.

The technician must be very careful to use Tooling (A) correctly. The following points must be remembered:

- Ensure that the backs of the bearings and the bores are clean and dry.
- Ensure that the bearing locking tabs are properly seated in the tab grooves.

- The crankshaft must be free of oil at the contact points of Tooling (A).

1. Put a piece of Tooling (A) on the crown of the bearing that is in the cap.

Note: Do not allow Tooling (A) to extend over the edge of the bearing.

2. Use the correct torque-turn specifications in order to install the bearing cap. Do not use an impact wrench. Be careful not to dislodge the bearing when the cap is installed.

Note: Do not turn the crankshaft when Tooling (A) is installed.

3. Carefully remove the cap, but do not remove Tooling (A). Measure the width of Tooling (A) while Tooling (A) is in the bearing cap or on the crankshaft journal. Refer to Illustration 239.

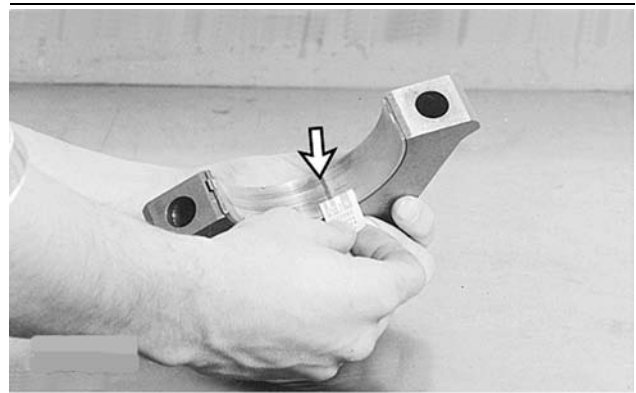

Illustration 239

g00473227

Typical Example

4. Remove all of Tooling (A) before you install the bearing cap.

Note: When Tooling (A) is used, the readings can sometimes be unclear. For example, all parts of Tooling (A) are not the same width. Measure the major width in order to ensure that the parts are within the specification range. Refer to Specifications, "Crankshaft" for the correct clearances.

i01481332

Atmospheric Pressure Sensor - Remove and Install

SMCS Code: 1923-010

Removal Procedure

NOTICE

Keep all parts clean from contaminants.

Contaminants may cause rapid wear and shortened component life.

NOTICE

Care must be taken to ensure that fluids are contained during performance of inspection, maintenance, testing, adjusting and repair of the product. Be prepared to collect the fluid with suitable containers before opening any compartment or disassembling any component containing fluids.

Refer to Special Publication, NENG2500, "Caterpillar Tools and Shop Products Guide" for tools and supplies suitable to collect and contain fluids on Caterpillar products.

Dispose of all fluids according to local regulations and mandates.

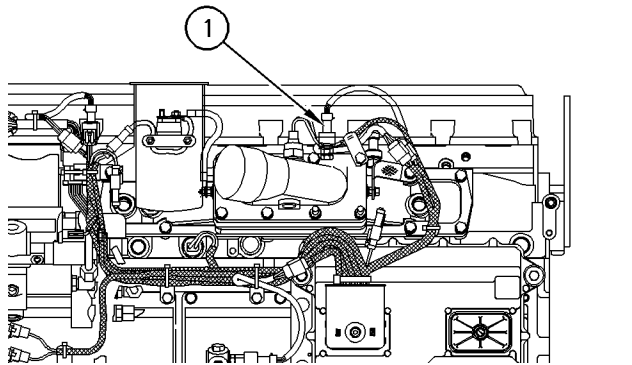

Illustration 240

g00772510

(1) Atmospheric pressure sensor

1. Disconnect the plug for atmospheric pressure sensor (1).
2. Remove atmospheric pressure sensor (1).

Installation Procedure

NOTICE

Keep all parts clean from contaminants.

Contaminants may cause rapid wear and shortened component life.

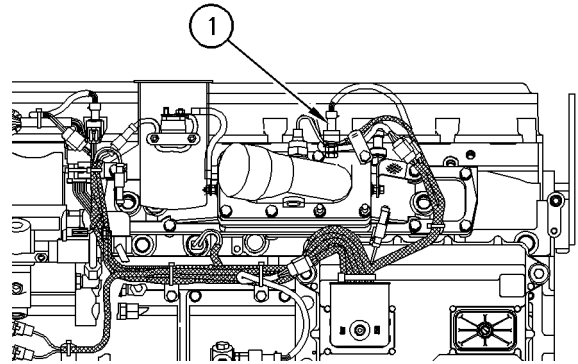

Illustration 241

g00772510

(1) Atmospheric pressure sensor

1. Install atmospheric pressure sensor (1). Tighten the atmospheric pressure sensor to a torque of 10 ± 2 N·m (90 ± 18 lb in).
2. Connect the plug for atmospheric pressure sensor (1).

i01748101

Coolant Temperature Sensor - Remove and Install

SMCS Code: 1906-010

Removal Procedure

NOTICE

Keep all parts clean from contaminants.

Contaminants may cause rapid wear and shortened component life.

NOTICE

Care must be taken to ensure that fluids are contained during performance of inspection, maintenance, testing, adjusting and repair of the product. Be prepared to collect the fluid with suitable containers before opening any compartment or disassembling any component containing fluids.

Refer to Special Publication, NENG2500, "Caterpillar Tools and Shop Products Guide" for tools and supplies suitable to collect and contain fluids on Caterpillar products.

Dispose of all fluids according to local regulations and mandates.

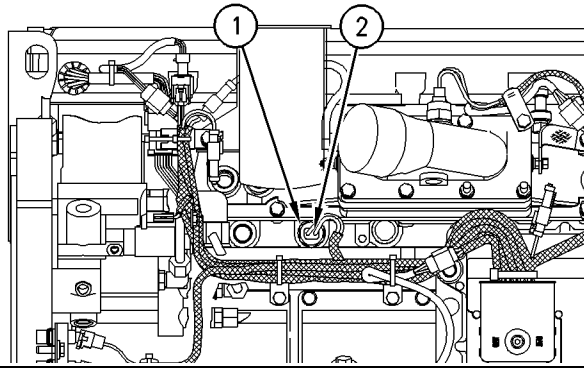

Illustration 242 g00770396

- (1) Coolant temperature sensor
- (2) Electrical connection for coolant temperature sensor

1. Disconnect plug (2) from coolant temperature sensor (1).
2. Remove coolant temperature sensor (1).

Installation Procedure

NOTICE

Keep all parts clean from contaminants.

Contaminants may cause rapid wear and shortened component life.

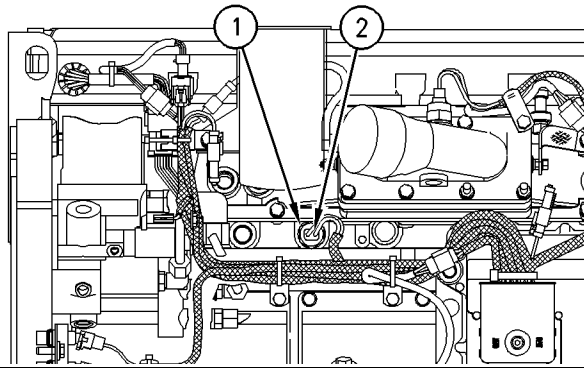

Illustration 243 g00770396

- (1) Coolant temperature sensor
- (2) Electrical connection for coolant temperature sensor

1. Install coolant temperature sensor (1). Tighten the coolant temperature sensor to a torque of 20 ± 5 N·m (15 ± 4 lb ft).
2. Connect plug (2) to coolant temperature sensor (1).

Engine Oil Pressure Sensor - Remove and Install

SMCS Code: 1924-010

Removal Procedure

NOTICE

Keep all parts clean from contaminants.

Contaminants may cause rapid wear and shortened component life.

NOTICE

Care must be taken to ensure that fluids are contained during performance of inspection, maintenance, testing, adjusting and repair of the product. Be prepared to collect the fluid with suitable containers before opening any compartment or disassembling any component containing fluids.

Refer to Special Publication, NENG2500, "Caterpillar Tools and Shop Products Guide" for tools and supplies suitable to collect and contain fluids on Caterpillar products.

Dispose of all fluids according to local regulations and mandates.

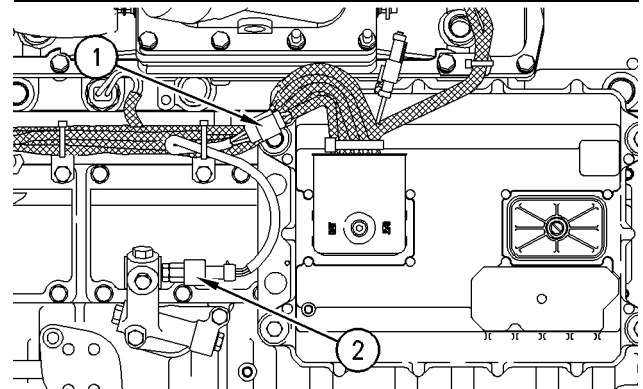

Illustration 244

g00770526

- (1) Electrical connection for engine oil pressure sensor
- (2) Engine oil pressure sensor

1. Disconnect plug (1) from engine oil pressure sensor (2).
2. Remove engine oil pressure sensor (2).

Installation Procedure

NOTICE

Keep all parts clean from contaminants.

Contaminants may cause rapid wear and shortened component life.

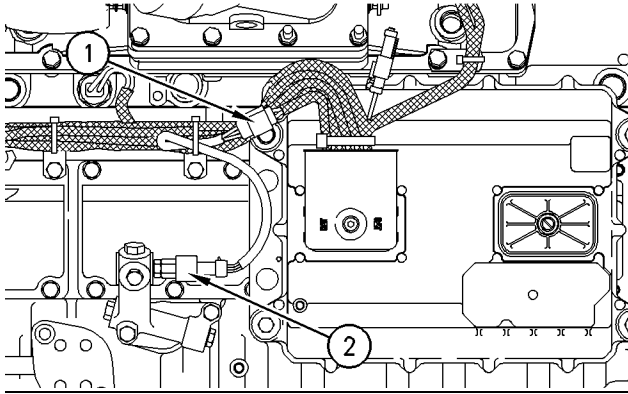

Illustration 245

g00770526

- (1) Electrical connection for engine oil pressure sensor
(2) Engine oil pressure sensor

1. Install engine oil pressure sensor (2). Tighten the engine oil pressure sensor to a torque of 10 ± 2 N·m (90 ± 18 lb in).
2. Connect plug (1) to engine oil pressure sensor (2).

i01481086

Engine Oil Temperature Sensor - Remove and Install

SMCS Code: 1929-010

Removal Procedure

NOTICE

Keep all parts clean from contaminants.

Contaminants may cause rapid wear and shortened component life.

NOTICE

Care must be taken to ensure that fluids are contained during performance of inspection, maintenance, testing, adjusting and repair of the product. Be prepared to collect the fluid with suitable containers before opening any compartment or disassembling any component containing fluids.

Refer to Special Publication, NENG2500, "Caterpillar Tools and Shop Products Guide" for tools and supplies suitable to collect and contain fluids on Caterpillar products.

Dispose of all fluids according to local regulations and mandates.

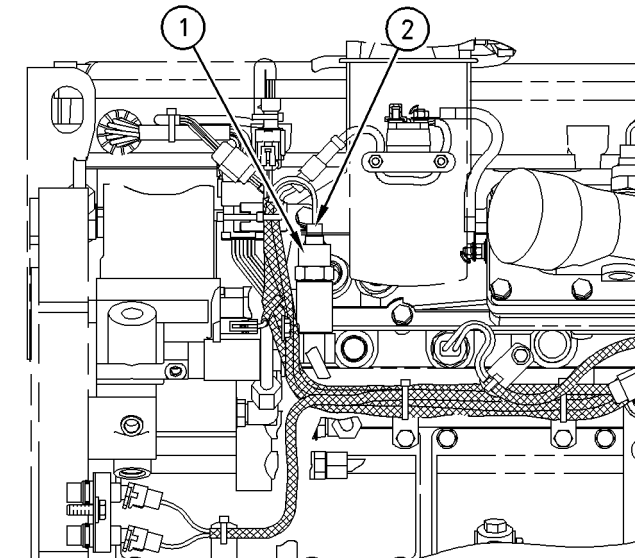

Illustration 246

g00771060

- (1) Engine oil temperature sensor
(2) Electrical connection for engine oil temperature sensor

1. Disconnect plug (2) for engine oil temperature sensor (1).
2. Remove engine oil temperature sensor (1).

Installation Procedure

NOTICE

Keep all parts clean from contaminants.

Contaminants may cause rapid wear and shortened component life.

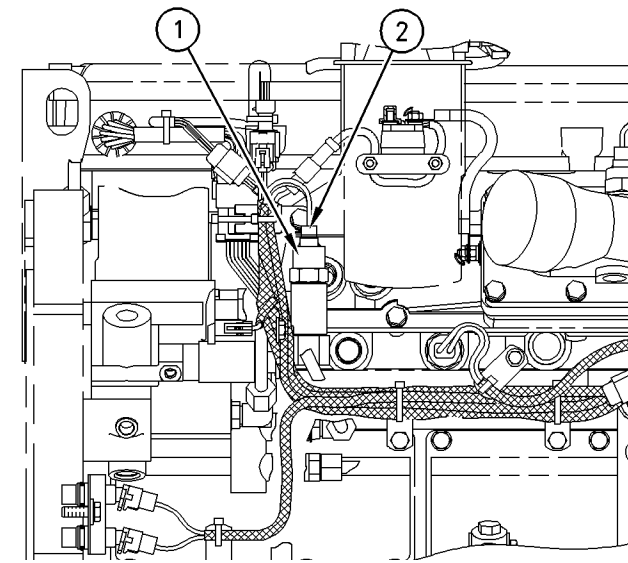

Illustration 247

g00771060

- (1) Engine oil temperature sensor
(2) Electrical connection for engine oil temperature sensor

1. Install engine oil temperature sensor (1). Tighten the engine oil temperature sensor to a torque of 10 ± 2 N·m (90 ± 18 lb in).
2. Connect plug (2) for engine oil temperature sensor (1).

i01479662

Injection Actuation Pressure Sensor - Remove and Install

SMCS Code: 1925-010

Removal Procedure

NOTICE

Keep all parts clean from contaminants.

Contaminants may cause rapid wear and shortened component life.

NOTICE

Care must be taken to ensure that fluids are contained during performance of inspection, maintenance, testing, adjusting and repair of the product. Be prepared to collect the fluid with suitable containers before opening any compartment or disassembling any component containing fluids.

Refer to Special Publication, NENG2500, "Caterpillar Tools and Shop Products Guide" for tools and supplies suitable to collect and contain fluids on Caterpillar products.

Dispose of all fluids according to local regulations and mandates.

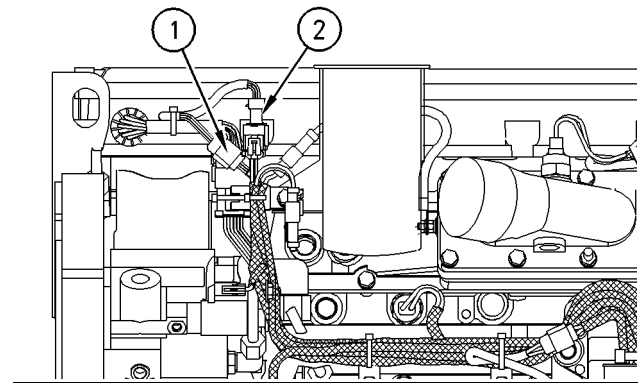

Illustration 248

g00770496

- (1) Electrical connection for injection actuation pressure sensor
(2) Injection actuation pressure sensor

1. Disconnect plug (1) from injection actuation pressure sensor (2).
2. Remove injection actuation pressure sensor (2).

Installation Procedure

NOTICE

Keep all parts clean from contaminants.

Contaminants may cause rapid wear and shortened component life.

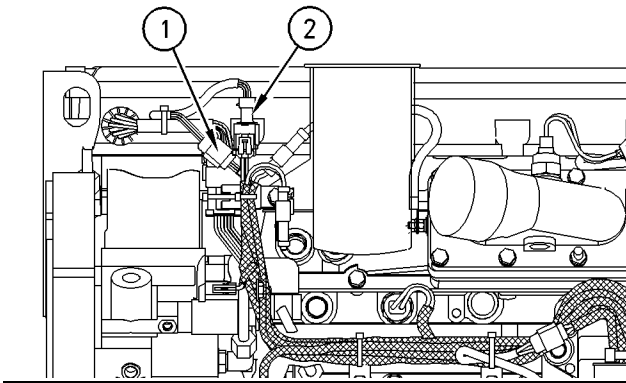

Illustration 249

g00770496

- (1) Electrical connection for injection actuation pressure sensor
(2) Injection actuation pressure sensor

1. Install injection actuation pressure sensor (2). Tighten the injection actuation pressure sensor to a torque of 10 ± 2 N·m (90 ± 18 lb in).
2. Connect plug (1) to injection actuation pressure sensor (2).

i01481228

Speed/Timing Sensor - Remove and Install

SMCS Code: 1907-010; 1912-010

Removal Procedure

NOTICE

Keep all parts clean from contaminants.

Contaminants may cause rapid wear and shortened component life.

NOTICE

Care must be taken to ensure that fluids are contained during performance of inspection, maintenance, testing, adjusting and repair of the product. Be prepared to collect the fluid with suitable containers before opening any compartment or disassembling any component containing fluids.

Refer to Special Publication, NENG2500, "Caterpillar Tools and Shop Products Guide" for tools and supplies suitable to collect and contain fluids on Caterpillar products.

Dispose of all fluids according to local regulations and mandates.

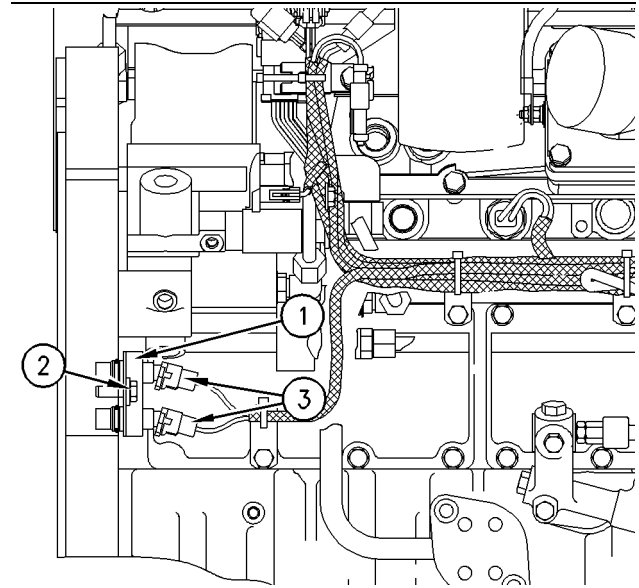

Illustration 250

g00771142

- (1) Speed/timing sensors
(2) Bolt
(3) Electrical connections for speed/timing sensors

1. Disconnect plugs (3) for speed/timing sensors (1).
2. Remove bolt (2) that fastens the speed/timing sensors to the engine.
3. Remove speed/timing sensors (1).

Installation Procedure

NOTICE

Keep all parts clean from contaminants.

Contaminants may cause rapid wear and shortened component life.

Note: The speed/timing sensors must be replaced as a pair.

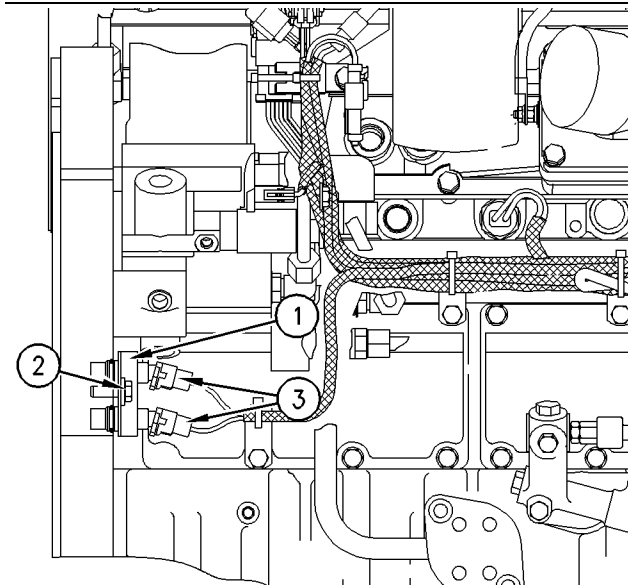

Illustration 251

g00771142

- (1) Speed/timing sensors
- (2) Bolt
- (3) Electrical connections for speed/timing sensors

1. Position speed/timing sensors (1) on the engine.

Note: Ensure that the speed/timing sensors are seated on the sensor flanges before you tighten the bolt on the bracket.

- 2. Install bolt (2) that fastens the speed/timing sensors on the engine.
- 3. Connect plugs (3) for speed/timing sensors (1).

i01481057

Boost Pressure Sensor - Remove and Install

SMCS Code: 1917-010

Removal Procedure

NOTICE

Keep all parts clean from contaminants.

Contaminants may cause rapid wear and shortened component life.

NOTICE

Care must be taken to ensure that fluids are contained during performance of inspection, maintenance, testing, adjusting and repair of the product. Be prepared to collect the fluid with suitable containers before opening any compartment or disassembling any component containing fluids.

Refer to Special Publication, NENG2500, "Caterpillar Tools and Shop Products Guide" for tools and supplies suitable to collect and contain fluids on Caterpillar products.

Dispose of all fluids according to local regulations and mandates.

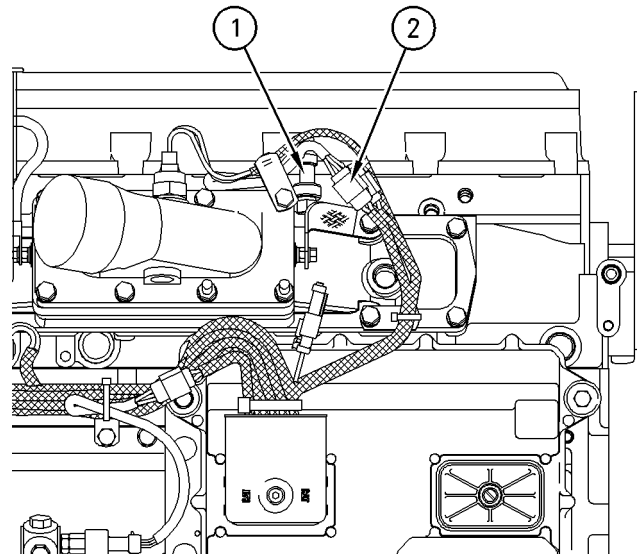

Illustration 252

g00771041

- (1) Boost pressure sensor
- (2) Electrical connection for boost pressure sensor

- 1. Disconnect plug (2) for boost pressure sensor (1).
- 2. Remove boost pressure sensor (1).

Installation Procedure

NOTICE

Keep all parts clean from contaminants.

Contaminants may cause rapid wear and shortened component life.

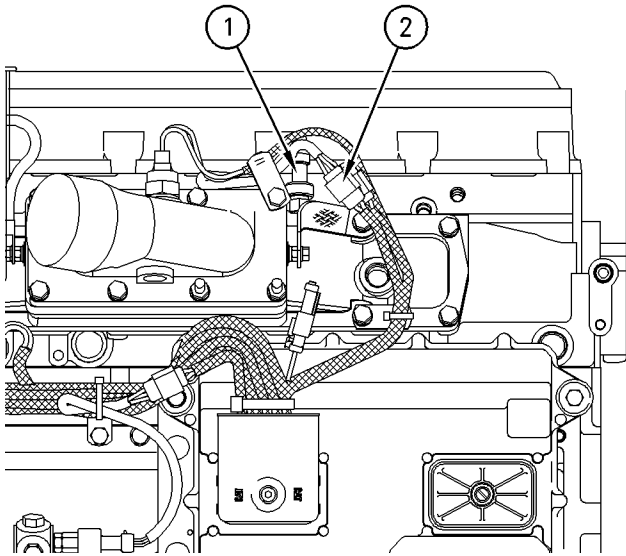

Illustration 253

g00771041

- (1) Boost pressure sensor
(2) Electrical connection for boost pressure sensor

1. Install boost pressure sensor (1). Tighten the boost pressure sensor to a torque of 10 ± 2 N·m (90 ± 18 lb in).
2. Connect plug (2) for boost pressure sensor (1).

i01481365

Inlet Air Temperature Sensor - Remove and Install

SMCS Code: 1921-010

Removal Procedure

NOTICE

Keep all parts clean from contaminants.

Contaminants may cause rapid wear and shortened component life.

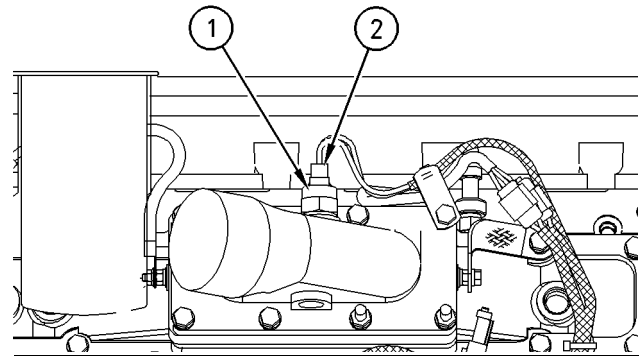

Illustration 254

g00771192

Typical example

- (1) Inlet air temperature sensor
(2) Electrical connection for inlet air temperature sensor

1. Disconnect plug (2) for inlet air temperature sensor (1).
2. Remove inlet air temperature sensor (1).

Installation Procedure

NOTICE

Keep all parts clean from contaminants.

Contaminants may cause rapid wear and shortened component life.

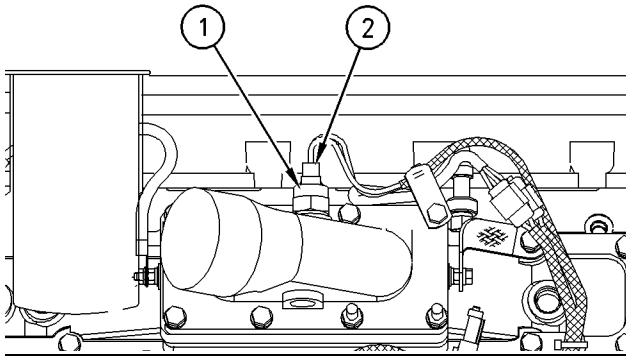

Illustration 255 g00771192

Typical example

- (1) Inlet air temperature sensor
- (2) Electrical connection for inlet air temperature sensor

1. Install inlet air temperature sensor (1). Tighten the inlet air temperature sensor to a torque of 20 ± 5 N·m (15 ± 4 lb ft).
2. Connect plug (2) for inlet air temperature sensor (1).

i01161409

Idler Pulley - Remove

SMCS Code: 1358-011

Removal Procedure

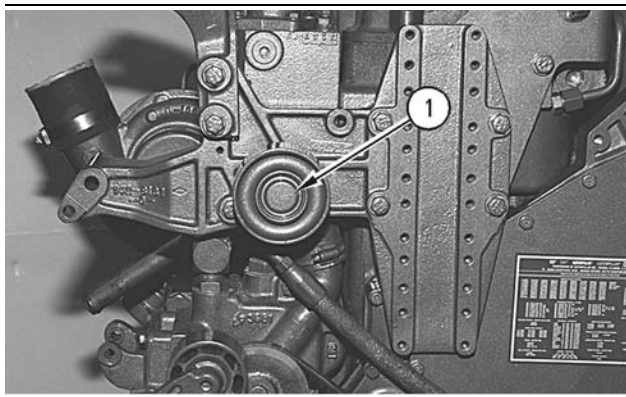

Illustration 256 g00618468

1. Remove cover (1) from the idler pulley. Cover (1) will be damaged during removal.

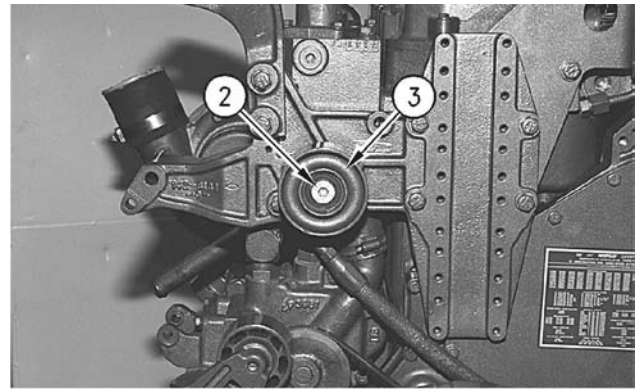

Illustration 257 g00618473

2. Remove bolt (2) and idler pulley (3).

i01748107

Idler Pulley - Disassemble

SMCS Code: 1358-015

Disassembly Procedure

Table 47

Required Tools			
Tool	Part Number	Part Description	Qty
A	1P-0510	Driver Group	1
B	1P-1855	Retaining Ring Pliers	1

Start By:

- a. Remove the idler pulley. Refer to Disassembly and Assembly, "Idler Pulley - Remove".

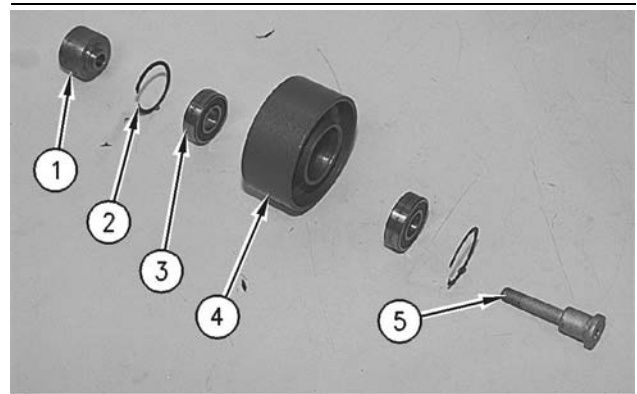

Illustration 258 g00618635

1. Remove spacer (1) and bolt (5) from idler pulley (4).

i01161430

2. Remove retaining rings (2) from each side of idler pulley (4) with Tooling (B).
3. Remove bearings (3) from each side of idler pulley (4) with Tooling (A).

i01748112

Idler Pulley - Assemble

SMCS Code: 1358-016

Assembly Procedure

Table 48

Required Tools			
Tool	Part Number	Part Description	Qty
A	1P-0510	Driver Group	1

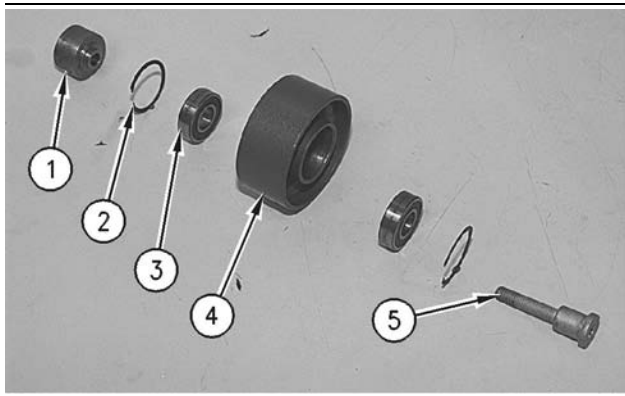

Illustration 259

g00618635

1. Install one retaining ring (2) in idler pulley (4).
2. Install two bearings (3) in idler pulley (4) with Tooling (A). Install the remaining retaining ring (2).
3. Install spacer (1) and bolt (5) in idler pulley (4).

End By:

- a. Install the idler pulley. Refer to Disassembly and Assembly, "Idler Pulley - Install".

Idler Pulley - Install

SMCS Code: 1358-012

Installation Procedure

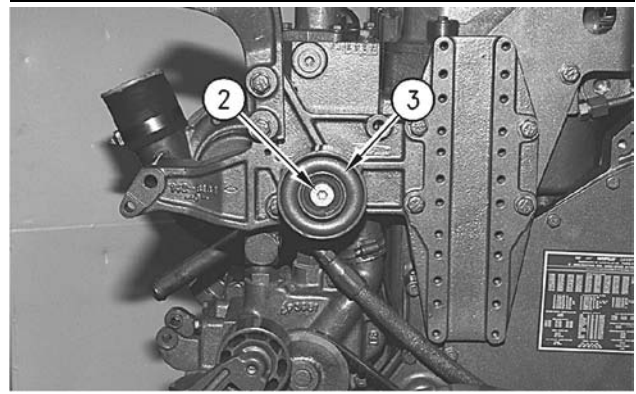

Illustration 260

g00618473

1. Position idler pulley (3). Install bolt (2) and tighten bolt (2) to a torque of 55 ± 10 N·m (40 ± 7 lb ft).

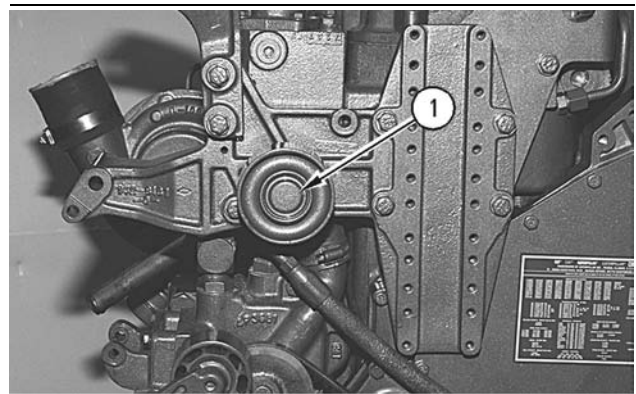

Illustration 261

g00618468

2. Install a new cover (1) on idler pulley (3).

i01581372

Belt Tensioner - Remove and Install

SMCS Code: 1358-010

Removal Procedure

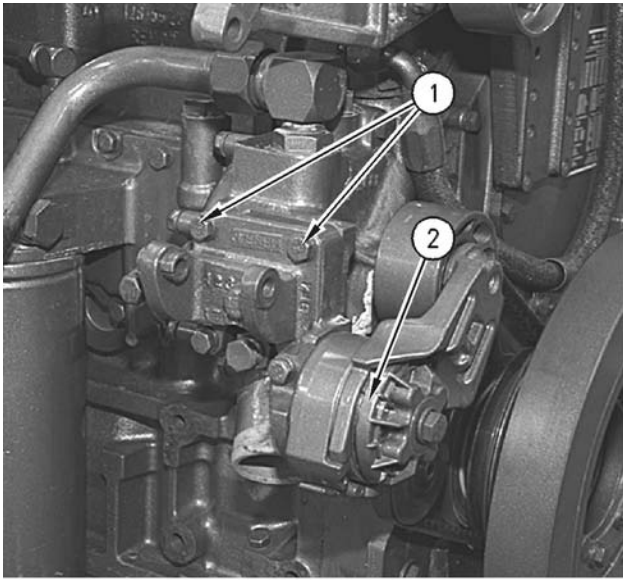

Illustration 262

g00614167

1. Use a breaker bar to release the tension on belt tensioner (2). Remove the drive belt.
2. Remove four bolts (1) and belt tensioner (2).

Installation Procedure

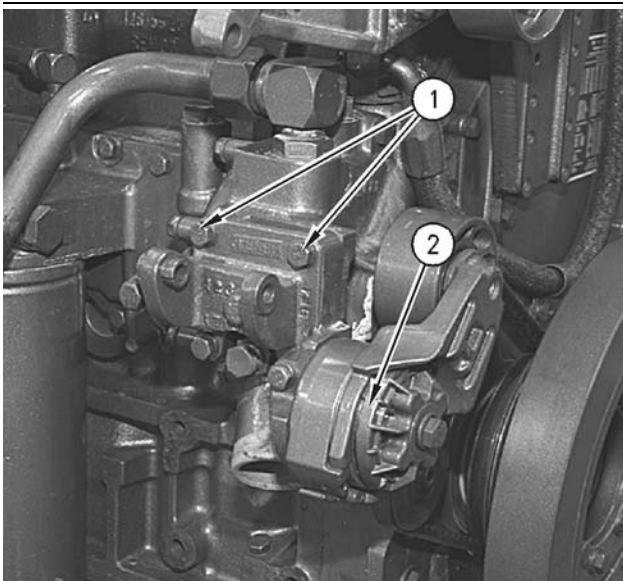

Illustration 263

g00614167

1. Position belt tensioner (2) on the cylinder block. Install four bolts (1).
2. Install the drive belt. Use a breaker bar to release tension on the belt tensioner.

i01162446

Belt Tightener - Remove

SMCS Code: 1358-011

Removal Procedure

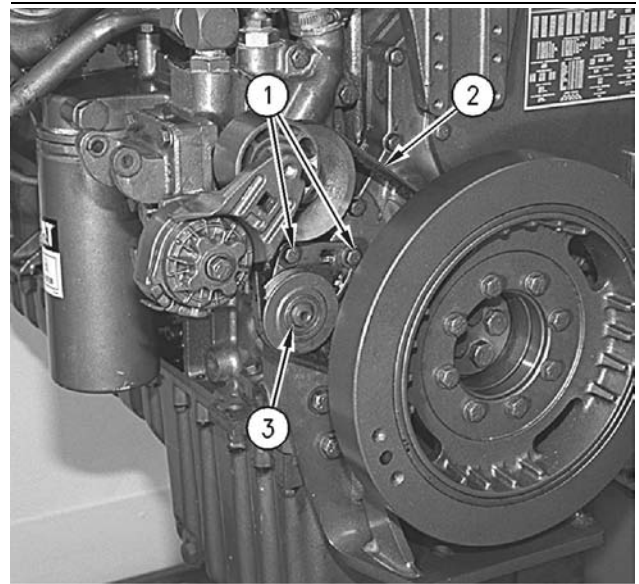

Illustration 264

g00619355

1. Remove two bolts (1) that hold water pump belt tightener (3) to the timing gear housing.
2. Remove V-belt (2) from the pulley of water pump belt tightener (3). Remove water pump belt tightener (3).

i01748118

i01761781

Belt Tightener - Disassemble

SMCS Code: 1358-015

Disassembly Procedure

Table 49

Required Tools			
Tool	Part Number	Part Description	Qty
A	1P-1855	Retaining Ring Pliers	1
B	1P-0510	Driver Group	1

Start By:

- a. Remove the water pump belt tightener. Refer to Disassembly and Assembly, "Belt Tightener - Remove".

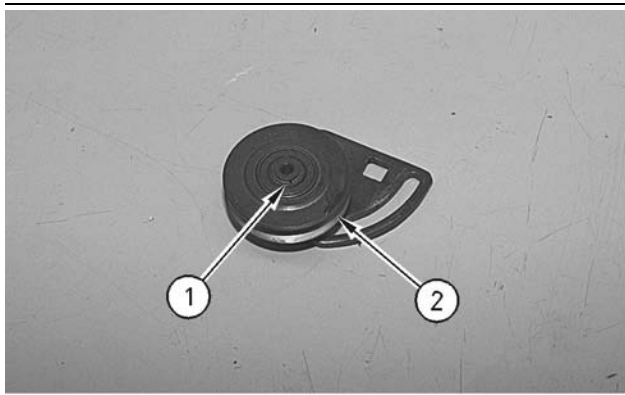

Illustration 265

g00619391

1. Use Tooling (A) to remove retaining ring (1). Remove pulley (2) from the idler plate assembly.

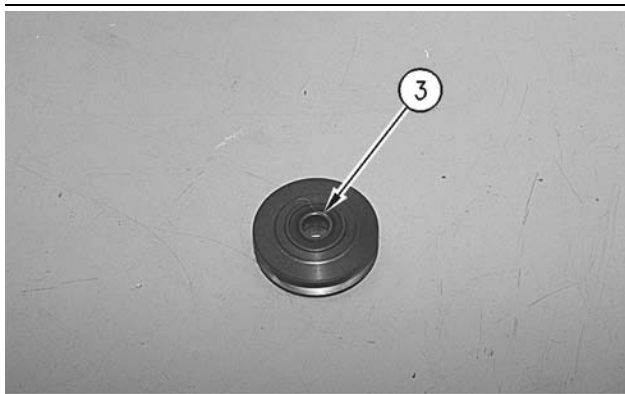

Illustration 266

g00619393

2. Remove two bearings (3) from pulley (2) with a press and Tooling (B).

Belt Tightener - Assemble

SMCS Code: 1358-016

Assembly Procedure

Table 50

Required Tools			
Tool	Part Number	Part Description	Qty
A	1P-1855	Retaining Ring Pliers	1
B	1P-0510	Driver Gp	1

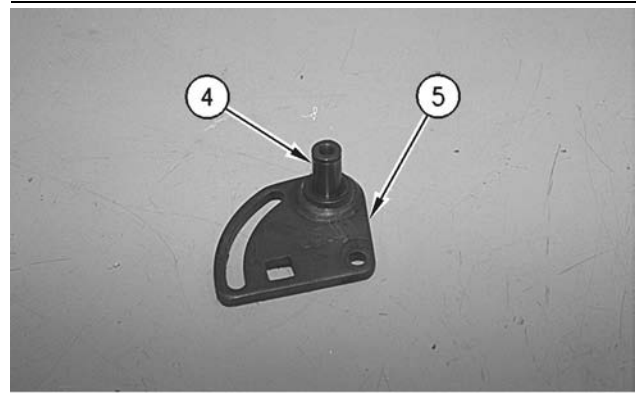

Illustration 267

g00619412

1. Check the condition of shaft (4) in idler plate assembly (5). Replace idler plate assembly (5) if shaft (4) is worn.

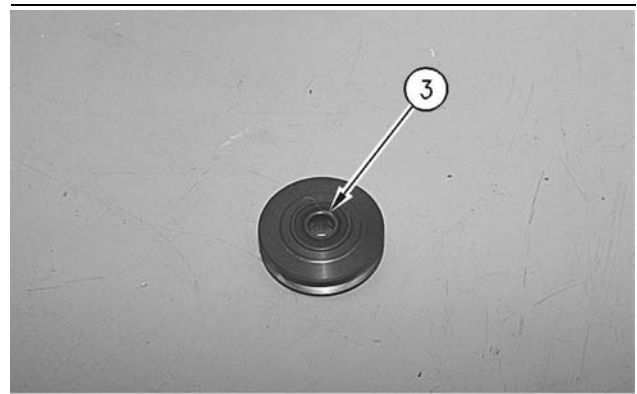

Illustration 268

g00619393

2. Thoroughly clean the following components: the bearing bore in the pulley, the outside bearing bore of the pulley, and the outside diameter of two bearings (3). Apply 9S-3263 Thread Lock Compound in the bearing bore of the pulley and on the outside diameter of two bearings (3). Install two bearings (3) in the pulley with Tooling (B). Ensure that bearings (3) are centered in the pulley.

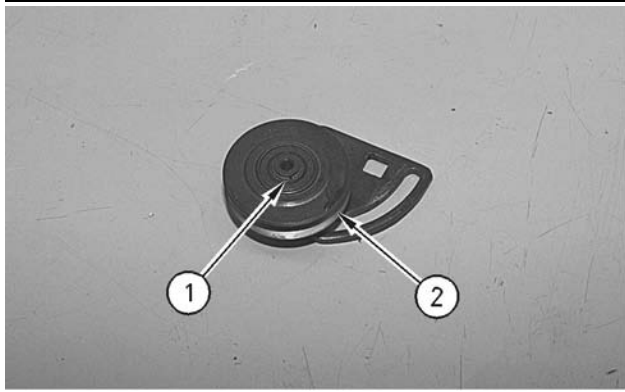

Illustration 269

g00619391

3. Install pulley (2) on the idler plate assembly. Install retaining ring (1) with Tooling (A) in order to hold pulley (2) to the idler plate assembly.

End By:

- a. Install the water pump belt tightener. Refer to Disassembly and Assembly, "Belt Tightener - Install".

i01162480

Belt Tightener - Install

SMCS Code: 1358-012

Installation Procedure

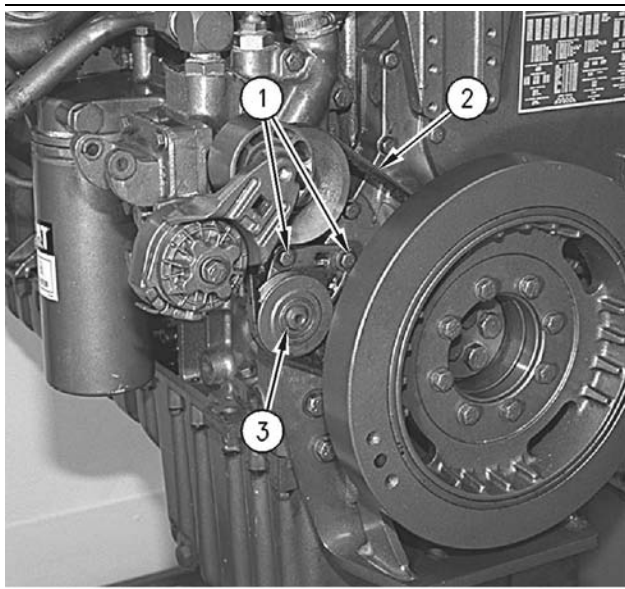

Illustration 270

g00619355

1. Position water pump belt tightener (3) and install V-belt (2) on the pulley of water pump belt tightener (3).

2. Install two bolts (1) that hold water pump belt tightener (3) to the timing gear housing.
3. Adjust the tension of V-belt (2). Refer to Operation and Maintenance Manual, "Belt Tension Chart".

i01748138

Fan Drive Mounting Group - Remove and Install

SMCS Code: 1359

Removal Procedure

Start By:

- a. Remove the engine cooling fan and the fan drive. Refer to Disassembly and Assembly, "Fan Drive - Remove".
- b. Remove the alternator. Refer to Disassembly and Assembly, "Alternator - Remove and Install".
- c. If equipped, move the refrigerant compressor free of the fan drive.

Note: Refer to "For removal of fan drive mounting support as. only" for water pump maintenance. This procedure is only for engines that are equipped with a two-piece fan drive mounting.

One-Piece Fan Drive Mounting (If Equipped)

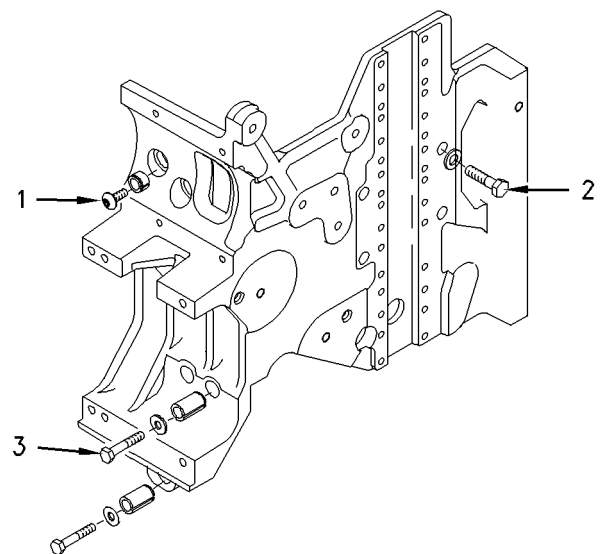

Illustration 271

g00813626

1. Remove screws (1).

2. Loosen four bolts (2).
3. Remove the bolts (3) and washers.

Note: Make sure that the fan drive mounting is properly supported prior to step 4.

4. Remove the bolts (2).
5. Remove the fan drive mounting.

Two-Piece Fan Drive Mounting (If Equipped)

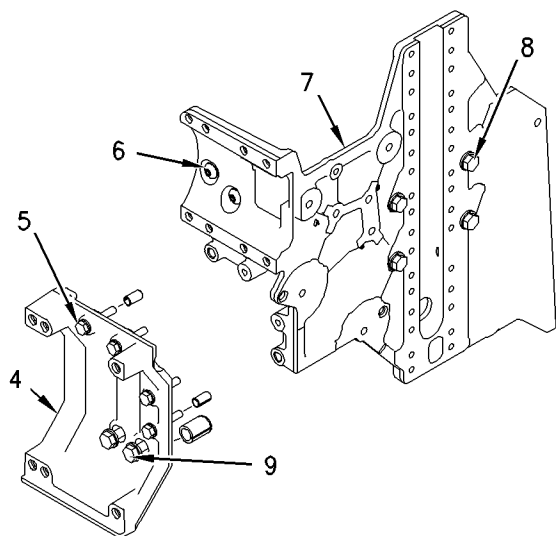

Illustration 272

g00849133

Removal of fan drive mounting support assembly only

Reference: Item (4) in illustration.

1. Remove four bolts (5).
2. Remove two bolts (9).

Removal of fan drive mounting plate

1. Remove bolts (5) and (9) from support assembly (4) of fan drive mounting.
2. Remove the screws (6) from the water regulator housing.

Note: Make sure that fan drive mounting (7) is adequately supported prior to Step 3.

3. Remove the four bolts and the washers from the front face of the fan drive mounting.

Installation Procedure

One-Piece Fan Drive Mounting

1. Assemble the engine lifting bracket and the fan drive mounting to the engine. Tighten four bolts (2) finger tight. Tighten three bolts (3) finger tight.
2. Tighten the front primary bolts (2) to a torque of 55 ± 10 N·m (40 ± 7 lb ft).
3. Tighten bolts (3) to a torque of 28 ± 7 N·m (20 ± 5 lb ft).
4. Tighten the screws (1) into the water regulator housing.

Two-Piece Fan Drive Mounting

Installation of the fan drive mounting support assembly only

1. Tighten bolts (5) to standard torque.
2. Tighten bolts (9) to standard torque.

Installation of the entire fan drive mounting

1. Assemble the engine lifting bracket and the fan drive mounting to the engine.
2. Tighten the front bolts (8) and washers finger tight.
3. Tighten screws (6) finger tight.
4. Tighten bolts (5) to standard torque.
5. Tighten bolts (9) and washers finger tight.
6. Tighten the front bolts (4) to standard torque.
7. Tighten the bolts (9) to standard torque.
8. Tighten remaining hardware to standard torque.

End By:

- a. If equipped, install the refrigerant compressor.
- b. Install the alternator. Refer to Disassembly and Assembly, "Alternator - Remove and Install".
- c. Install the engine fan and fan drive. Refer to Disassembly and Assembly, "Fan Drive - Remove".

i01148551

i01748145

Fan Drive - Remove

SMCS Code: 1359-011

Removal Procedure

Start By:

- a. Remove the alternator. Refer to Disassembly and Assembly, "Alternator - Remove and Install".

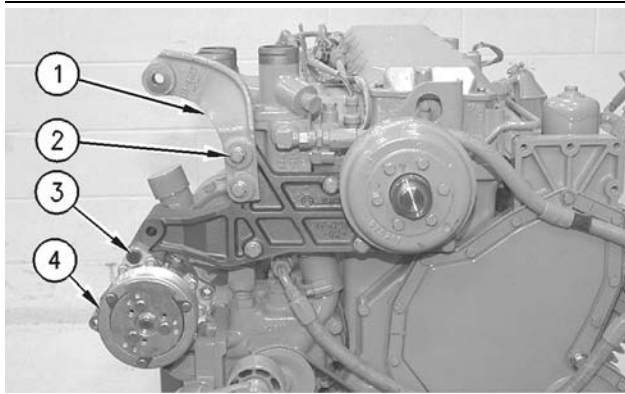

Illustration 273

g00609660

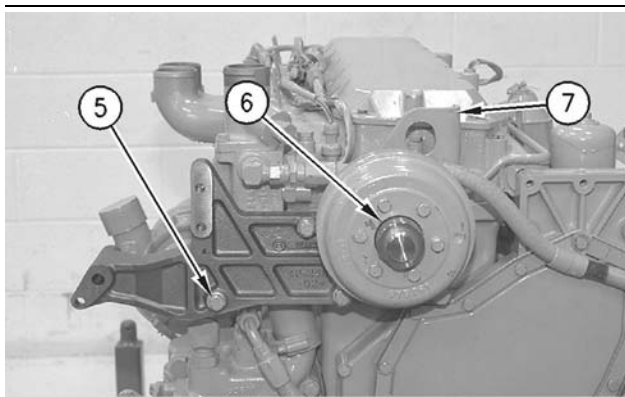

Illustration 274

g00609661

1. Remove two bolts (2) and remove alternator bracket (1).
2. If equipped, remove three bolts (3), the washers, and the nuts. Remove refrigerant compressor (4).
3. Remove six bolts (5) and the washers. Remove fan drive (6) and front lifting group (7) from the cylinder head assembly.

Fan Drive - Install

SMCS Code: 1359-012

Installation Procedure

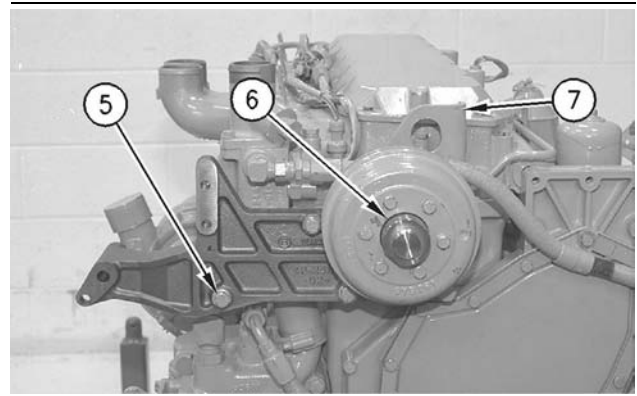

Illustration 275

g00609661

1. Position fan drive (6) and front lifting group (7) on the cylinder head assembly. Install six bolts (5) and the washers.

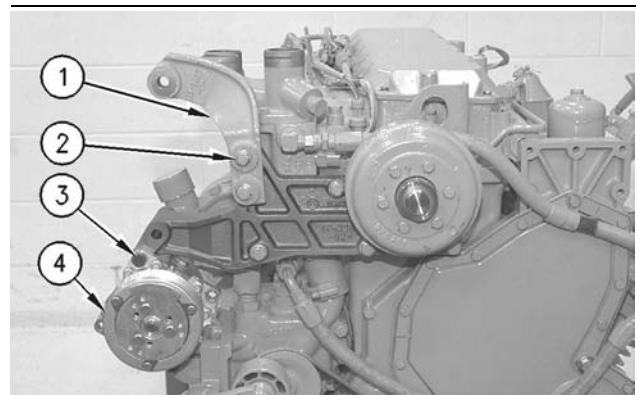

Illustration 276

g00609660

2. If equipped, position refrigerant compressor (4). Install three bolts (3), the washers, and the nuts.
3. Position alternator bracket (1). Install two bolts (2).

End By:

- a. Install the alternator. Refer to Disassembly and Assembly, "Alternator - Remove and Install".

i01377485

i01699673

Engine Control Module - Remove and Install

SMCS Code: 1901-010

Removal Procedure

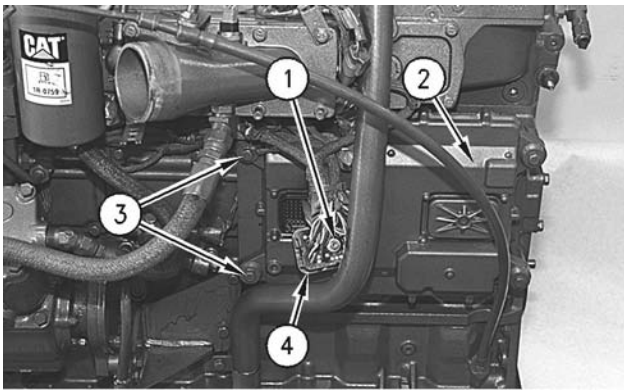

Illustration 277

g00609591

1. Loosen screw (1) until wiring harness (4) can be disconnected. Disconnect wiring harness (4) from engine control module (2).
2. Remove four bolts (3). Remove the engine control module from the engine.

Installation Procedure

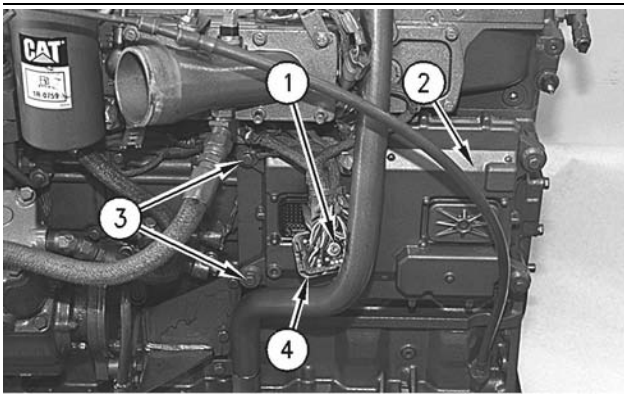

Illustration 278

g00609591

1. Position engine control module (2) on the engine and install four bolts (3).
2. Connect wiring harness (4) to engine control module (2). Tighten screw (1) to a torque of 6 ± 1 N·m (53 ± 9 lb in).

Alternator - Remove and Install

SMCS Code: 1405-010

Removal Procedure

Table 51

Required Tools			
Tool	Part Number	Part Description	Qty
A	168-0383	Circuit Breaker Bar	1

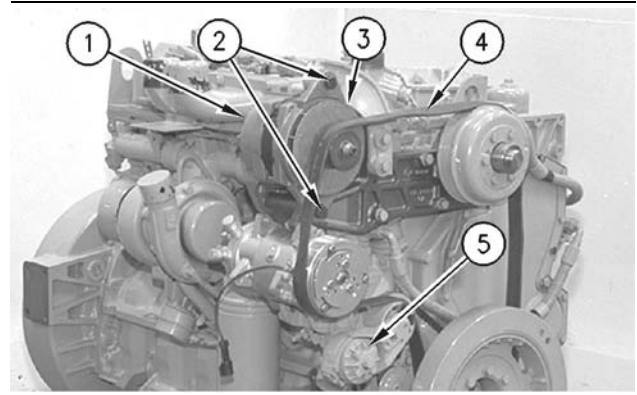

Illustration 279

g00609523

Typical Example

Note: Release the tension on the belt at the belt tightener, if the engine is not equipped with a belt tensioner.

1. Use Tooling (A) to release the tension on belt tensioner (5).
2. Remove drive belt (4) from the drive pulley on alternator (3).
3. Place an index mark on all electrical wires (1) that are connected to the alternator. Disconnect electrical wires (1) from the alternator.
4. Remove two bolts (2).
5. Remove alternator (3) from the mounting bracket.

Installation Procedure

Table 52

Required Tools			
Tool	Part Number	Part Description	Qty
A	168-0383	Circuit Breaker Bar	1

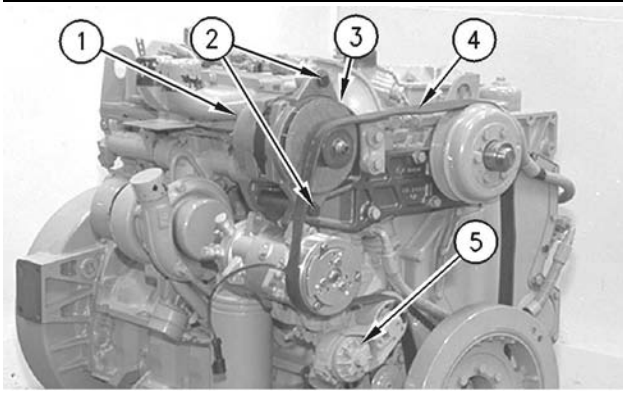

Illustration 280
Typical example

1. Position alternator (3) on the mounting bracket. Install bolts (2).
2. Use Tooling (A) to install drive belt (4) on the drive pulley of the alternator.

Note: Adjust the tension on the drive belt if the engine is not equipped with a belt tensioner. Refer to the Operation and Maintenance Manual for the correct adjusting procedure.

3. Connect wires (1) to the alternator. Use the index marks to correctly connect the wires. Tighten the mounting bolt for the ground wire to a torque of 6.2 ± 0.6 N·m (54 ± 5 lb in). Tighten the mounting bolt for the battery wire to a torque of 11.3 ± 2.3 N·m (100 ± 20 lb in).

i01748192

Electric Starting Motor - Remove and Install

SMCS Code: 1453-010

Removal Procedure

WARNING

Personal injury can result from failure to disconnect the battery.

First, disconnect the negative battery cable. Then, disconnect the positive battery cable.

A positive power lead can cause sparks if the battery is not disconnected. Sparks can possibly result in battery explosion or fire.

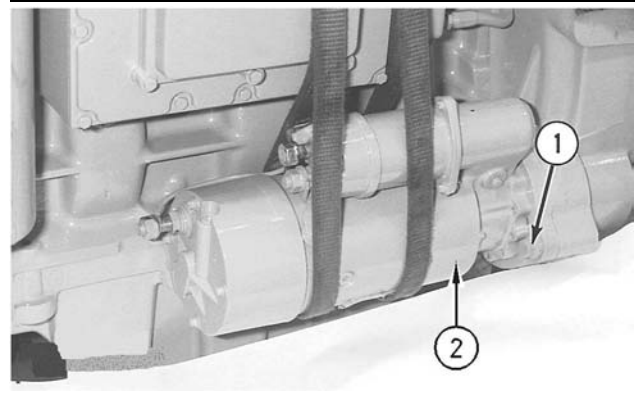

Illustration 281
Typical example

1. Place an index mark on all of the electrical wires that are connected to the electric starting motor. Disconnect the electrical wires from the electric starting motor (2).
2. Fasten a suitable lifting device to the electric starting motor.
3. Remove three bolts (1).
4. Remove the electric starting motor and the gasket from the flywheel housing. The weight of the electric starting motor is approximately 29 kg (65 lb).

Installation Procedure

1. Inspect the condition of the gasket. Replace the gasket, if necessary.

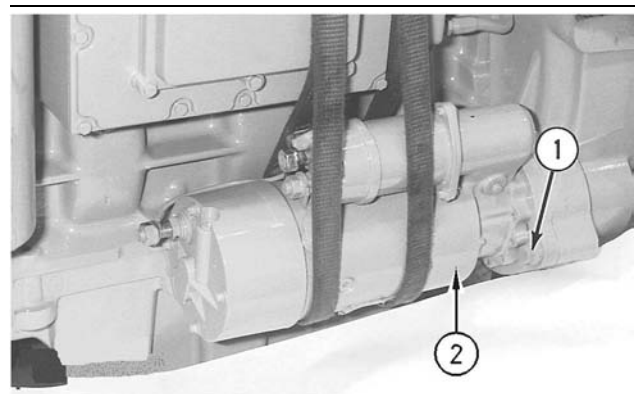

Illustration 282
Typical example

2. Install the gasket on the electric starting motor (2).
3. Fasten a suitable lifting device to the electric starting motor.

4. Place the electric starting motor in the flywheel housing. Install three bolts (1).
5. Connect all of the electrical wires to the electric starting motor by using the index marks.

i01748218

Air Compressor - Remove and Install

SMCS Code: 1803-010

Removal Procedure

Table 53

Required Tools			
Tool	Part Number	Part Description	Qty
A	138-7573	Link Bracket	1

WARNING

Do not disconnect the air lines until the air pressure in the system is at zero. If hose is disconnected under pressure it can cause personal injury.

NOTICE

Keep all parts clean from contaminants.

Contaminants may cause rapid wear and shortened component life.

NOTICE

Care must be taken to ensure that fluids are contained during performance of inspection, maintenance, testing, adjusting and repair of the product. Be prepared to collect the fluid with suitable containers before opening any compartment or disassembling any component containing fluids.

Refer to Special Publication, NENG2500, "Caterpillar Tools and Shop Products Guide" for tools and supplies suitable to collect and contain fluids on Caterpillar products.

Dispose of all fluids according to local regulations and mandates.

1. Remove the air pressure from the air tank and drain the coolant from the cooling system.

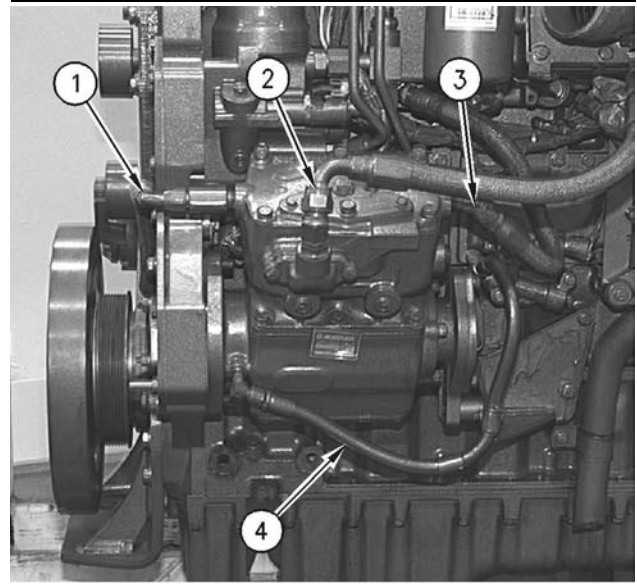

Illustration 283

g00609682

2. Disconnect water hose (1) and water hose (3) from the air compressor.
3. Disconnect air hose (2) and oil hose (4) from the air compressor.
4. Install Tooling (A) and a proper lifting device to the air compressor. The weight of the air compressor is approximately 23 kg (51 lb).
5. Remove the mounting bracket for a Midland EL-740 air compressor by using the following procedure:

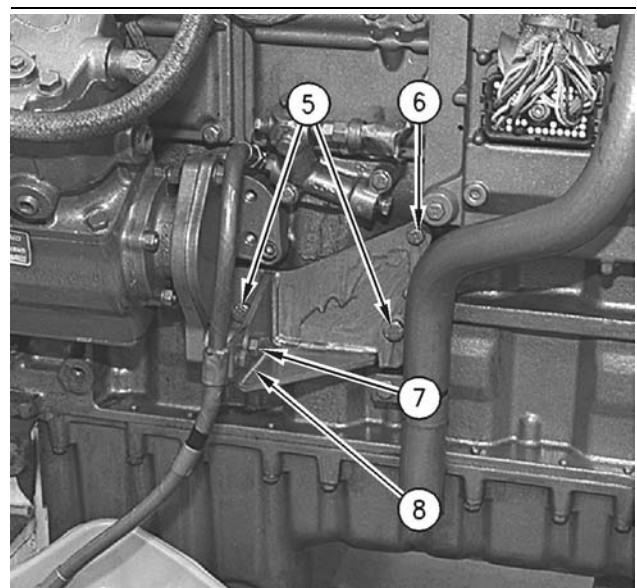

Illustration 284

g00609684

- a. Remove bolt (8) and the clip for the oil hose from the bracket for the air compressor.

- b. Remove two bolts (5) and bolt (6) that fastens the bracket for the air compressor to the cylinder block. Remove bolt (7) and the spacer between the air compressor and the bracket for the air compressor. Remove the bracket for the air compressor.
6. Remove the mounting bracket for a Bendix Tu-Flo 550 and Bendix Tu-Flo 750 air compressors by using the following procedure:

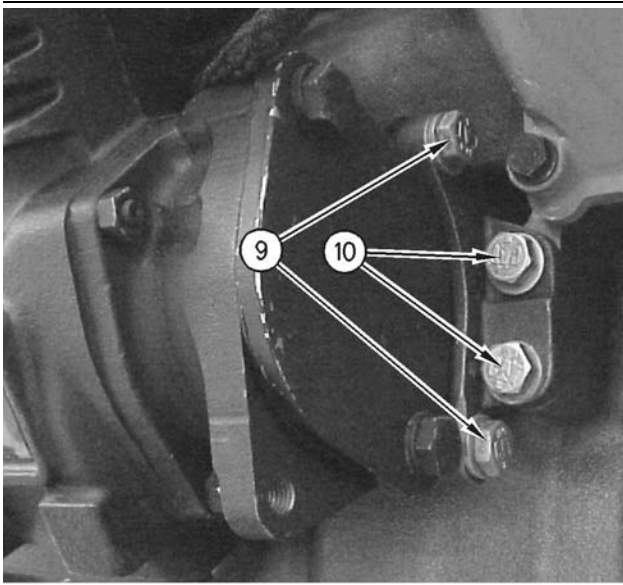

Illustration 285

g00705242

Typical example

- a. Remove bolts (9) that fasten the mounting bracket to the air compressor.
- b. Remove bolts (10) that fasten the mounting bracket to the cylinder block. Remove the mounting bracket for the air compressor.

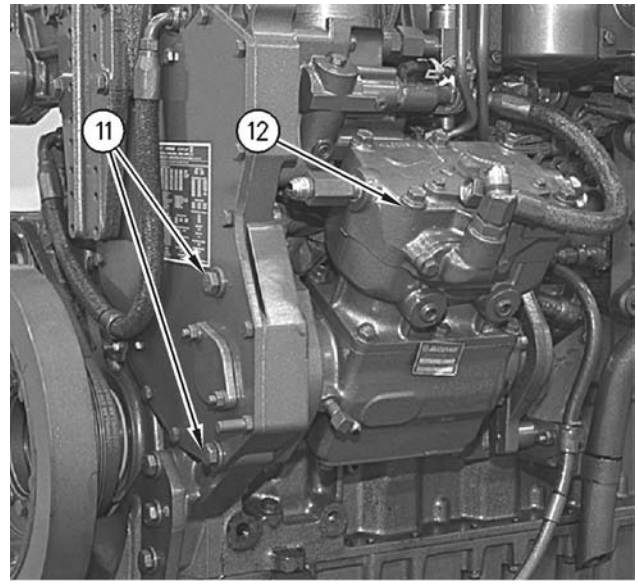

Illustration 286

g00705313

- 7. Remove bolts (11), air compressor (12), and the gasket from the timing gear housing.

Installation Procedure

Table 54

Required Tools			
Tool	Part Number	Part Description	Qty
A	138-7573	Link Bracket	1

NOTICE

Keep all parts clean from contaminants.

Contaminants may cause rapid wear and shortened component life.

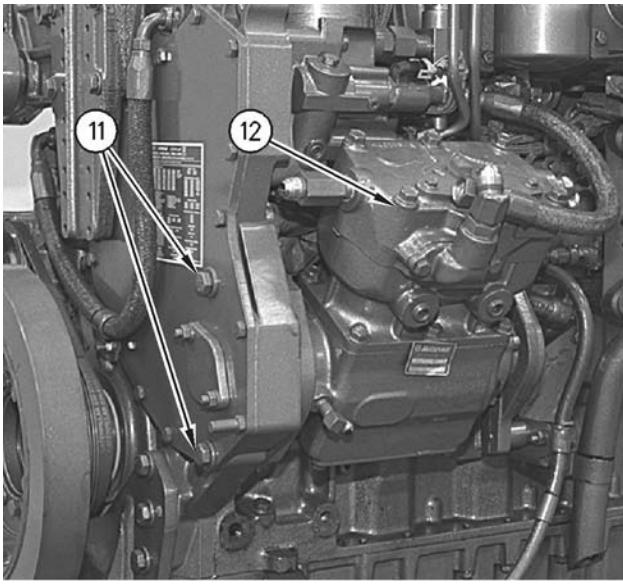

Illustration 287

g00705313

1. Install Tooling (A) and a proper lifting device to the air compressor. The weight of the air compressor is approximately 23 kg (51 lb).
2. Inspect the condition of the gasket. Replace the gasket, if necessary. Install the gasket between air compressor (12) and the timing gear housing.
3. Position air compressor (12) in the front housing. Ensure that the drive gear engages correctly with the gear in the front housing.
4. Apply **9S-3263** Thread Lock Compound to the threads of two bolts (11). Install two bolts (11). Tighten bolts (11) to a torque of 100 ± 20 N·m (75 ± 15 lb ft).
5. Install the mounting bracket for a Midland EL-740 air compressor by using the following procedure:

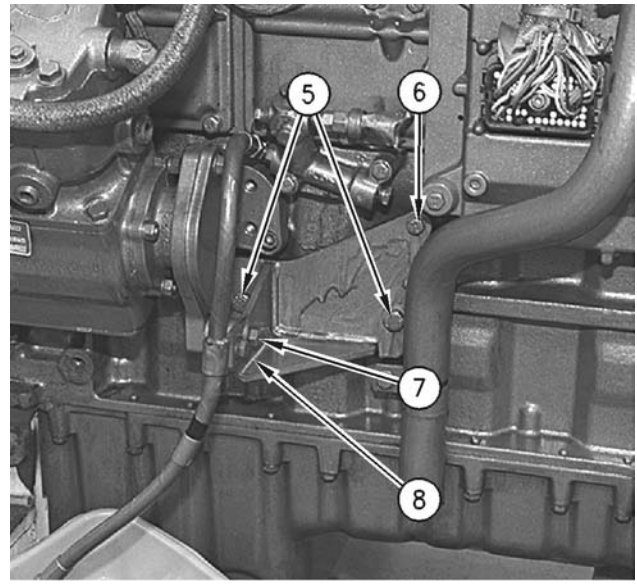

Illustration 288

g00609684

- a. Position the bracket for the air compressor and install bolts (5) and (6). Install the spacer and bolt (7). Hand tighten all bolts.

NOTICE

A loose compressor bracket can lead to a broken front cover and can cause damage to the front gear train of the engine.

- b. Tighten bolt (7) to a torque of 50 ± 10 N·m (37 ± 7 lb ft). Tighten bolt (5) to a torque of 55 ± 10 N·m (40 ± 7 lb ft). Tighten bolt (6) to a torque of 28 ± 7 N·m (21 ± 5 lb ft). Remove the lifting device and Tool (A).
6. Install the mounting bracket for Bendix Tu-Flo 550 and Bendix Tu-Flo 750 air compressors by using the following procedure:

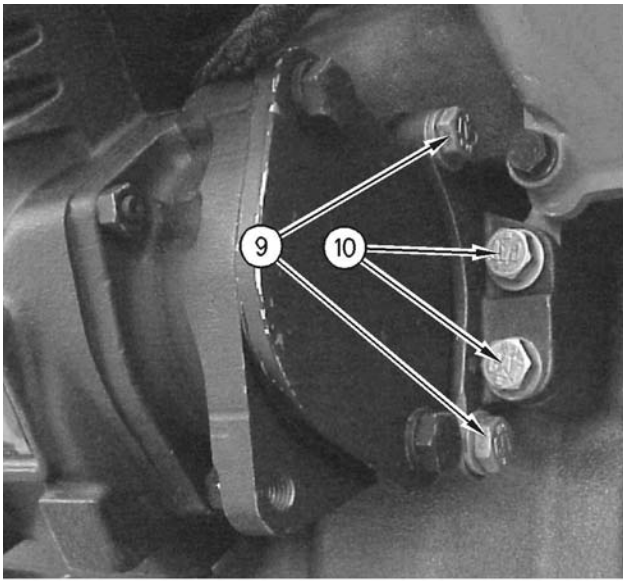

Illustration 289
Typical example

g00705242

- a. Position the bracket for the air compressor and install bolts (9) and bolts (10) finger tight.

NOTICE

A loose compressor bracket can lead to a broken front cover and can cause damage to the front gear train of the engine.

- b. Tighten bolts (9) to a torque of 55 ± 10 N·m (40 ± 7 lb ft). Tighten bolts (10) to a torque of 55 ± 10 N·m (40 ± 7 lb ft). Remove the lifting device and Tooling (A).

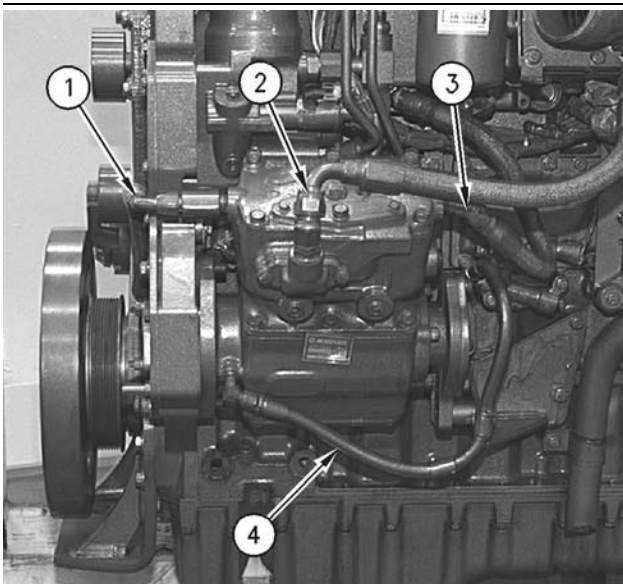

Illustration 290

g00609682

7. Connect oil hose assembly (4) to the air compressor. Connect the clip that holds the hose assembly to the air compressor. Tighten bolt (8) that holds the clip to a torque of 28 ± 7 N·m (21 ± 5 lb ft).
8. Connect water hose (1) and (3) to the air compressor.
9. Connect air hose (2) to the air compressor.
10. Fill the cooling system with coolant to the correct level. Refer to the Operation and Maintenance Manual for the correct filling procedure.

i01748230

Air Compressor Drive Gear - Remove

SMCS Code: 1803-011-GE

Removal Procedure

Table 55

Required Tools			
Tool	Part Number	Part Description	Qty
A	132-5451	Holding Fixture	1

Start By:

- a. Remove the air compressor. Refer to Disassembly and Assembly, "Air Compressor - Remove and Install".

NOTICE

Keep all parts clean from contaminants.

Contaminants may cause rapid wear and shortened component life.

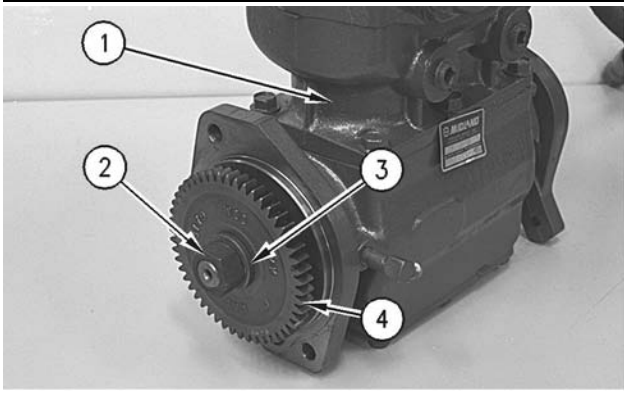

Illustration 291
Typical example
g00609907

1. Mount air compressor (1) in a bench vise.
2. Install Tooling (A) on the air compressor drive gear.
3. Remove nut (2) and washer (3).
4. Remove air compressor drive gear (4).

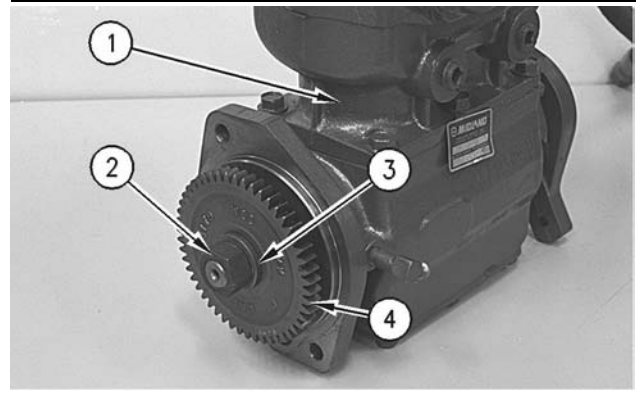

Illustration 292
Typical example
g00609907

1. Use 138-8440 Component Cleaner in order to clean the inside diameter of gear (4) and the outside diameter of the drive shaft for the air compressor.
2. Lubricate washer (3) and the threads on the drive shaft with clean engine oil.
3. Mount air compressor (1) in a bench vise.
4. Install air compressor drive gear (4) on the air compressor crankshaft.
5. Install washer (3) and nut (2).
6. Install Tooling (A) on the air compressor drive gear.
7. Tighten nut (2) to a torque of 165 ± 10 N·m (120 ± 7 lb ft).
8. Place a driver which is slightly larger than the nut over the nut and tap the driver with a hammer.
9. Tighten the nut again to a torque of 165 ± 10 N·m (120 ± 7 lb ft).

End By:

- a. Install the air compressor. Refer to Disassembly and Assembly, "Air Compressor - Remove and Install".

i01761562

Air Compressor Drive Gear - Install

SMCS Code: 1803-012-GE

Installation Procedure

Table 56

Required Tools			
Tool	Part Number	Part Description	Qty
A	132-5451	Holding Fixture	1

NOTICE

Keep all parts clean from contaminants.

Contaminants may cause rapid wear and shortened component life.

Index

A

Air Compressor - Remove and Install.....	111
Installation Procedure	112
Removal Procedure	111
Air Compressor Drive Gear - Install.....	115
Installation Procedure	115
Air Compressor Drive Gear - Remove.....	114
Removal Procedure	114
Air Inlet Cover - Remove and Install	30
Installation Procedure	31
Removal Procedure	30
Air Inlet Heater - Remove and Install.....	29
Installation Procedure	29
Removal Procedure	29
Air Inlet Heater Solenoid - Remove and Install.....	30
Installation Procedure	30
Removal Procedure	30
Alternator - Remove and Install	109
Installation Procedure	109
Removal Procedure	109
Atmospheric Pressure Sensor - Remove and Install	95
Installation Procedure	95
Removal Procedure	95

B

Bearing Clearance - Check	94
Measurement Procedure	94
Belt Tensioner - Remove and Install	104
Installation Procedure	104
Removal Procedure	104
Belt Tightener - Assemble	105
Assembly Procedure	105
Belt Tightener - Disassemble	105
Disassembly Procedure	105
Belt Tightener - Install.....	106
Installation Procedure	106
Belt Tightener - Remove.....	104
Removal Procedure	104
Boost Pressure Sensor - Remove and Install.....	100
Installation Procedure	100
Removal Procedure	100

C

Camshaft - Install.....	79
Installation Procedure	79
Camshaft - Remove.....	78
Removal Procedure	78
Camshaft Gear - Remove and Install	80
Installation Procedure	80
Removal Procedure	80

Camshaft Idler Gear - Remove and Install	66
Installation Procedure	67
Removal Procedure	66
Coolant Temperature Sensor - Remove and Install	95
Installation Procedure	96
Removal Procedure	95
Crankshaft - Install.....	91
Installation Procedure	91
Crankshaft - Remove.....	91
Removal Procedure	91
Crankshaft Front Seal - Install	63
Installation Procedure	63
Crankshaft Front Seal - Remove	63
Removal Procedure	63
Crankshaft Gear - Remove and Install	93
Installation Procedure	93
Removal Procedure	93
Crankshaft Main Bearings - Install.....	90
Installation Procedure	90
Crankshaft Main Bearings - Remove.....	89
Removal Procedure	89
Crankshaft Rear Seal - Install.....	49
Installation Procedure	49
Crankshaft Rear Seal - Remove.....	49
Removal Procedure	49
Crankshaft Rear Seal Carrier - Remove and Install	52
Installation Procedure	52
Removal Procedure	52
Crankshaft Wear Sleeve (Rear) - Install	51
Installation Procedure	51
Crankshaft Wear Sleeve (Rear) - Remove (If Equipped)	51
Removal Procedure	51
Cylinder Head - Install	75
Installation Procedure	75
Cylinder Head - Remove	74
Removal Procedure	74

D

Disassembly and Assembly Section.....	5
---------------------------------------	---

E

Electric Starting Motor - Remove and Install	110
Installation Procedure	110
Removal Procedure	110
Engine Control Module - Remove and Install	109
Installation Procedure	109
Removal Procedure	109
Engine Oil Filter Base - Assemble.....	37
Assembly Procedure	37
Engine Oil Filter Base - Disassemble	36
Disassembly Procedure	36

Engine Oil Filter Base - Install	37
Installation Procedure	37
Engine Oil Filter Base - Remove	35
Removal Procedure	35
Engine Oil Pan - Remove and Install.....	81
Installation Procedure	81
Removal Procedure	81
Engine Oil Pressure Sensor - Remove and Install..	96
Installation Procedure	97
Removal Procedure	96
Engine Oil Pump - Assemble.....	40
Assembly Procedure.....	40
Engine Oil Pump - Disassemble.....	38
Disassembly Procedure	38
Engine Oil Pump - Install.....	41
Installation Procedure	41
Engine Oil Pump - Remove	38
Removal Procedure	38
Engine Oil Temperature Sensor - Remove and Install	97
Installation Procedure	97
Removal Procedure	97
Exhaust Manifold - Remove and Install	24
Installation Procedure	25
Removal Procedure	24
Exhaust Particulate Filter - Assemble.....	28
Assembly Procedure.....	28
Exhaust Particulate Filter - Disassemble.....	26
Disassembly Procedure	26
 F	
Fan Drive - Install.....	108
Installation Procedure	108
Fan Drive - Remove.....	108
Removal Procedure	108
Fan Drive Mounting Group - Remove and Install..	106
Installation Procedure	107
Removal Procedure	106
Flywheel - Install.....	48
Installation Procedure	48
Flywheel - Remove	47
Removal Procedure	47
Flywheel Housing - Remove and Install	53
Installation Procedure	54
Removal Procedure	53
Front Cover - Install	64
Installation Procedure	64
Front Cover - Remove	64
Removal Procedure	64
Fuel Filter Base - Install.....	6
Installation Procedure	6
Fuel Filter Base - Remove	5
Removal Procedure	5
Fuel Pressure Regulator - Remove and Install.....	8
Installation Procedure	9
Removal Procedure	8
Fuel Transfer Pump - Install.....	7
Installation Procedure	7
Fuel Transfer Pump - Remove	6
Removal Procedure	6

 H	
Housing (Front) - Install	66
Installation Procedure	66
Housing (Front) - Remove	65
Removal Procedure	65
 I	
Idle Pulley - Assemble.....	103
Assembly Procedure.....	103
Idle Pulley - Disassemble	102
Disassembly Procedure	102
Idle Pulley - Install	103
Installation Procedure	103
Idle Pulley - Remove	102
Removal Procedure	102
Important Safety Information	2
Injection Actuation Pressure Control Valve - Assemble	18
Assembly Procedure.....	18
Injection Actuation Pressure Control Valve - Disassemble	18
Disassembly Procedure	18
Injection Actuation Pressure Control Valve - Install	19
Installation Procedure	19
Injection Actuation Pressure Control Valve - Remove	17
Removal Procedure	17
Injection Actuation Pressure Sensor - Remove and Install	98
Installation Procedure	98
Removal Procedure	98
Inlet Air Temperature Sensor - Remove and Install	101
Installation Procedure	101
Removal Procedure	101
Inlet and Exhaust Valve Guides - Remove and Install	32
Installation Procedure	33
Removal Procedure	32
Inlet and Exhaust Valve Seat Inserts - Remove and Install	34
Installation Procedure	35
Removal Procedure	34
Inlet and Exhaust Valves - Remove and Install	31
Installation Procedure	31
Removal Procedure	31

 L	
Lifter Group - Remove and Install.....	76
Installation Procedure	77
Removal Procedure	76

P

Piston Cooling Jets - Remove and Install 82
 Installation Procedure 83
 Removal Procedure 82
Pistons and Connecting Rods - Assemble 85
 Assembly Procedure 85
Pistons and Connecting Rods - Disassemble 84
 Disassembly Procedure 84
Pistons and Connecting Rods - Install 87
 Installation Procedure 87
Pistons and Connecting Rods - Remove 83
 Removal Procedure 83

R

Rear Power Take-Off (RPTO) - Assemble 58
 Installation Procedure 58
Rear Power Take-Off (RPTO) - Disassemble 55
 Removal Procedure 55
Rocker Shaft - Assemble 73
 Assembly Procedure 73
Rocker Shaft - Disassemble 72
 Disassembly Procedure 72
Rocker Shaft and Pushrod - Install 73
 Installation Procedure 73
Rocker Shaft and Pushrod - Remove 71
 Removal Procedure 71

S

Speed/Timing Sensor - Remove and Install 99
 Installation Procedure 99
 Removal Procedure 99

T

Table of Contents 3
Turbocharger - Install 24
 Installation Procedure 24
Turbocharger - Remove 23
 Removal Procedure 23

U

Unit Injector - Install 12
 Installation Procedure 12
Unit Injector - Remove 9
 Removal Procedure 9
Unit Injector Hydraulic Pump - Install 21
 Installation Procedure 21
Unit Injector Hydraulic Pump - Remove 19
 Removal Procedure 19
Unit Injector Sleeve - Install 17
 Installation Procedure 17
Unit Injector Sleeve - Remove 16
 Removal Procedure 16

V

Valve Mechanism Cover - Remove and Install 68
 Installation Procedure 69
 Removal Procedure 68
Valve Mechanism Cover Base - Remove and
 Install 70
 Installation Procedure 71
 Removal Procedure 70
Vibration Damper and Pulley - Remove and
 Install 62
 Installation Procedure 62
 Removal Procedure 62

W

Water Pump - Assemble 44
 Assembly Procedure 44
Water Pump - Disassemble 43
 Disassembly Procedure 43
Water Pump - Install 45
 Installation Procedure 45
Water Pump - Remove 42
 Removal Procedure 42
Water Temperature Regulator - Remove and
 Install 46
 Installation Procedure 47
 Removal Procedure 46

By Order of the Secretary of the Army:

PETER J. SCHOOMAKER
General, United States Army
Chief of Staff

Official:

JOEL B. HUDSON
Administrative Assistant to the
Secretary of the Army
0310005

DISTRIBUTION:

To be distributed in accordance with the initial distribution requirements for IDN: 381130
TM 9-2320-312-24-2.

**RECOMMENDED CHANGES TO PUBLICATIONS AND
BLANK FORMS**

For use of this form, see AR 25-30; the proponent agency is ODISC4.

Use Part II (*reverse*) for Repair Parts and Special Tool Lists (RPSTL) and Supply Catalogs/Supply Manuals (SC/SM).

DATE

10 Nov 03

TO: (*Forward to proponent of publication or form*) (*Include ZIP Code*)
AMSTA-LC-CI/TECH PUBS, TACOM-RI
1 Rock Island Arsenal
Rock Island, IL 61299-7630

FROM: (*Activity and location*) (*Include ZIP Code*)
125th Transportation Company
ATTN: Motor SGT (SGT Wilson)
Ft. Riley, KA 78665-4000

PART I - ALL PUBLICATIONS (EXCEPT RPSTL AND SC/SM) AND BLANK FORMS

PUBLICATION/FORM NUMBER

TM 9-2320-312-24-2

DATE

17 July 2003

TITLE

Unit, Direct Support, and General Support
Maintenance Manual for M878A2 Yard Tractor

ITEM	PAGE	PARA-	LINE	FIGURE NO.	TABLE	RECOMMENDED CHANGES AND REASON
	0017 00-2					Part number supplied for item 2 is incorrect.

SAMPLE

* Reference to line numbers within the paragraph or subparagraph.

TYPED NAME, GRADE OR TITLE

Johnny Wilson, E-5, MOTOR SGT

TELEPHONE EXCHANGE/AUTOVON,
PLUS EXTENSION

DSN 867-7967

SIGNATURE

RECOMMENDED CHANGES TO PUBLICATIONS AND BLANK FORMS						Use Part II (reverse) for Repair Parts and Special Tool Lists (RPSTL) and Supply Catalogs/Supply Manuals (SC/SM).	DATE
For use of this form, see AR 25-30: the proponent agency is ODISC4.							
TO: (Forward to proponent of publication or form) (Include ZIP Code) AMSTALC-LMIT / TECH PUBS, TACOM-RI 1 Rock Island Arsenal Rock Island, IL 61299-7630						FROM: (Activity and location) (Include ZIP Code)	
PART I - ALL PUBLICATIONS (EXCEPT RPSTL AND SC/SM) AND BLANK FORMS							
PUBLICATION/FORM NUMBER TM 9-2320-312-24-2						DATE 17 DECEMBER 2003	TITLE M878A2 Truck, Tractor, Yard Type
ITEM NO.	PAGE NO.	PARA-GRAPH	LINE NO. *	FIGURE NO.	TABLE NO.	RECOMMENDED CHANGES AND REASON (Provide exact wording of recommended changes, if possible).	
<i>*Reference to line numbers within the paragraph or subparagraph.</i>							
TYPED NAME, GRADE OR TITLE				TELEPHONE EXCHANGE/AUTOVON, PLUS EXTENSION		SIGNATURE	

TO: <i>(Forward direct to addressee listed in publication)</i> AMSTALC-LMIT / TECH PUBS, TACOM-RI 1 Rock Island Arsenal Rock Island, IL 61299-7630	FROM: <i>(Activity and location) (Include ZIP Code)</i>	DATE
--	--	-------------

PART II – REPAIR PARTS AND SPECIAL TOOL LISTS AND SUPPLY CATALOGS/SUPPLY MANUALS

PUBLICATION NUMBER TM 9-2320-312-24-2					DATE 17 DECEMBER 2003		TITLE M878A2 Truck, Tractor, Yard Type	
PAGE NO.	COLM NO.	LINE NO.	NATIONAL STOCK NUMBER	REFERENCE NO.	FIGURE NO.	ITEM NO.	TOTAL NO. OF MAJOR ITEMS SUPPORTED	RECOMMENDED ACTION

PART III – REMARKS *(Any general remarks or recommendations, or suggestions for improvement of publications and blank forms. Additional blank sheets may be used if more space is needed.)*

--

TYPED NAME, GRADE OR TITLE	TELEPHONE EXCHANGE/AUTOVON, PLUS EXTENSION	SIGNATURE
----------------------------	--	-----------

RECOMMENDED CHANGES TO PUBLICATIONS AND BLANK FORMS For use of this form, see AR 25-30; the proponent agency is ODISC4.						Use Part II (reverse) for Repair Parts and Special Tool Lists (RPSTL) and Supply Catalogs/Supply Manuals (SC/SM).	DATE
TO: (Forward to proponent of publication or form) (Include ZIP Code) AMSTALC-LMIT / TECH PUBS, TACOM-RI 1 Rock Island Arsenal Rock Island, IL 61299-7630						FROM: (Activity and location) (Include ZIP Code)	
PART I - ALL PUBLICATIONS (EXCEPT RPSTL AND SC/SM) AND BLANK FORMS							
PUBLICATION/FORM NUMBER TM 9-2320-312-24-2						DATE 17 DECEMBER 2003	TITLE M878A2 Truck, Tractor, Yard Type
ITEM NO.	PAGE NO.	PARA-GRAPH	LINE NO. *	FIGURE NO.	TABLE NO.	RECOMMENDED CHANGES AND REASON (Provide exact wording of recommended changes, if possible).	
<i>*Reference to line numbers within the paragraph or subparagraph.</i>							
TYPED NAME, GRADE OR TITLE					TELEPHONE EXCHANGE/AUTOVON, PLUS EXTENSION		SIGNATURE

TO: <i>(Forward direct to addressee listed in publication)</i> AMSTALC-LMIT / TECH PUBS, TACOM-RI 1 Rock Island Arsenal Rock Island, IL 61299-7630	FROM: <i>(Activity and location) (Include ZIP Code)</i>	DATE
--	--	-------------

PART II – REPAIR PARTS AND SPECIAL TOOL LISTS AND SUPPLY CATALOGS/SUPPLY MANUALS

PUBLICATION NUMBER TM 9-2320-312-24-2	DATE 17 DECEMBER 2003	TITLE M878A2 Truck, Tractor, Yard Type
---	---------------------------------	--

PAGE NO.	COLM NO.	LINE NO.	NATIONAL STOCK NUMBER	REFERENCE NO.	FIGURE NO.	ITEM NO.	TOTAL NO. OF MAJOR ITEMS SUPPORTED	RECOMMENDED ACTION

PART III – REMARKS *(Any general remarks or recommendations, or suggestions for improvement of publications and blank forms. Additional blank sheets may be used if more space is needed.)*

TYPED NAME, GRADE OR TITLE	TELEPHONE EXCHANGE/AUTOVON, PLUS EXTENSION	SIGNATURE
----------------------------	--	-----------

RECOMMENDED CHANGES TO PUBLICATIONS AND BLANK FORMS For use of this form, see AR 25-30; the proponent agency is ODISC4.	Use Part II (reverse) for Repair Parts and Special Tool Lists (RPSTL) and Supply Catalogs/Supply Manuals (SC/SM).	DATE
---	---	------

TO: (Forward to proponent of publication or form) (Include ZIP Code) AMSTALC-LMIT / TECH PUBS, TACOM-RI 1 Rock Island Arsenal Rock Island, IL 61299-7630	FROM: (Activity and location) (Include ZIP Code)
---	--

PART I - ALL PUBLICATIONS (EXCEPT RPSTL AND SC/SM) AND BLANK FORMS

PUBLICATION/FORM NUMBER TM 9-2320-312-24-2	DATE 17 DECEMBER 2003	TITLE M878A2 Truck, Tractor, Yard Type
---	--------------------------	---

ITEM NO.	PAGE NO.	PARA-GRAPH	LINE NO. *	FIGURE NO.	TABLE NO.	RECOMMENDED CHANGES AND REASON <i>(Provide exact wording of recommended changes, if possible).</i>
----------	----------	------------	------------	------------	-----------	---

ITEM NO.	PAGE NO.	PARA-GRAPH	LINE NO. *	FIGURE NO.	TABLE NO.	RECOMMENDED CHANGES AND REASON <i>(Provide exact wording of recommended changes, if possible).</i>

**Reference to line numbers within the paragraph or subparagraph.*

TYPED NAME, GRADE OR TITLE	TELEPHONE EXCHANGE/AUTOVON, PLUS EXTENSION	SIGNATURE
----------------------------	--	-----------

TO: <i>(Forward direct to addressee listed in publication)</i> AMSTALC-LMIT / TECH PUBS, TACOM-RI 1 Rock Island Arsenal Rock Island, IL 61299-7630	FROM: <i>(Activity and location) (Include ZIP Code)</i>	DATE
--	--	-------------

PART II – REPAIR PARTS AND SPECIAL TOOL LISTS AND SUPPLY CATALOGS/SUPPLY MANUALS

PUBLICATION NUMBER TM 9-2320-312-24-2	DATE 17 DECEMBER 2003	TITLE M878A2 Truck, Tractor, Yard Type
--	--------------------------	---

PAGE NO.	COLM NO.	LINE NO.	NATIONAL STOCK NUMBER	REFERENCE NO.	FIGURE NO.	ITEM NO.	TOTAL NO. OF MAJOR ITEMS SUPPORTED	RECOMMENDED ACTION

PART III – REMARKS *(Any general remarks or recommendations, or suggestions for improvement of publications and blank forms. Additional blank sheets may be used if more space is needed.)*

TYPED NAME, GRADE OR TITLE	TELEPHONE EXCHANGE/AUTOVON, PLUS EXTENSION	SIGNATURE
----------------------------	--	-----------

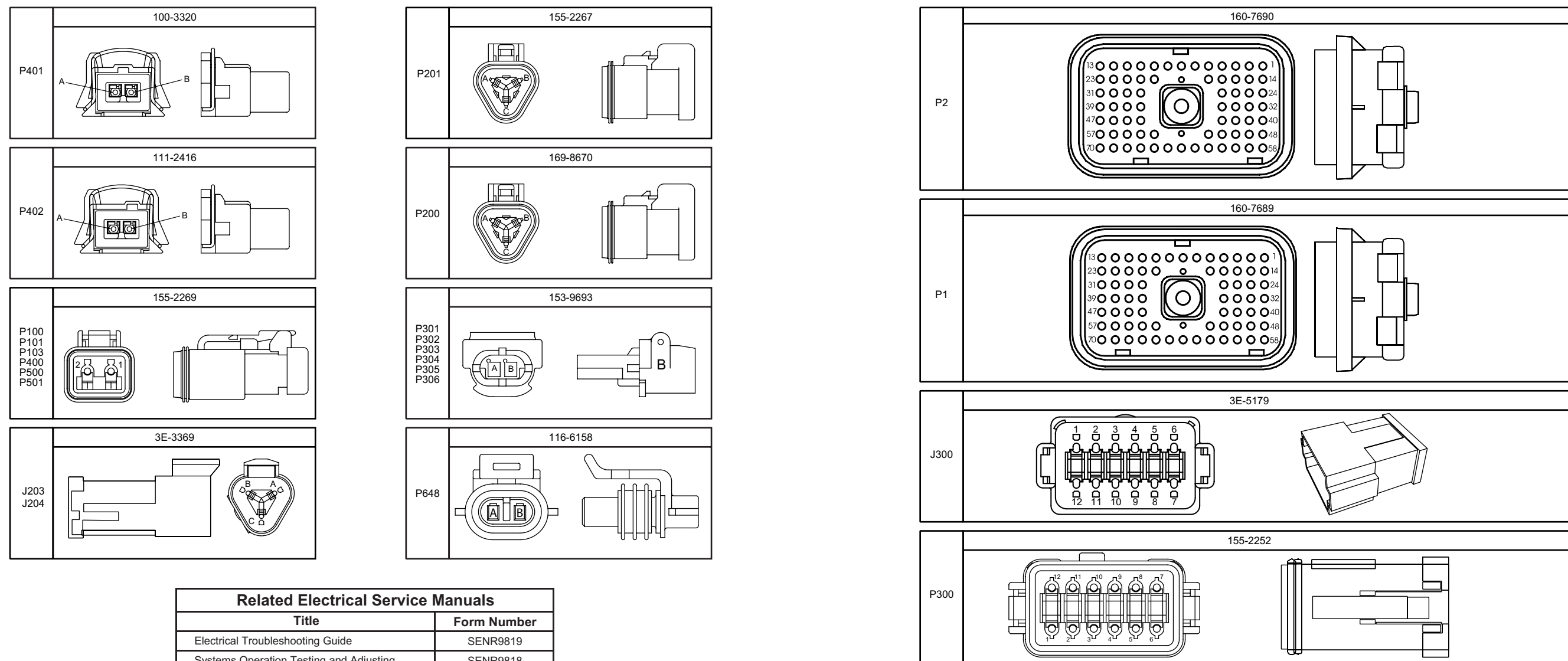

Related Electrical Service Manuals	
Title	Form Number
Electrical Troubleshooting Guide	SEN9819
Systems Operation Testing and Adjusting	SEN9818

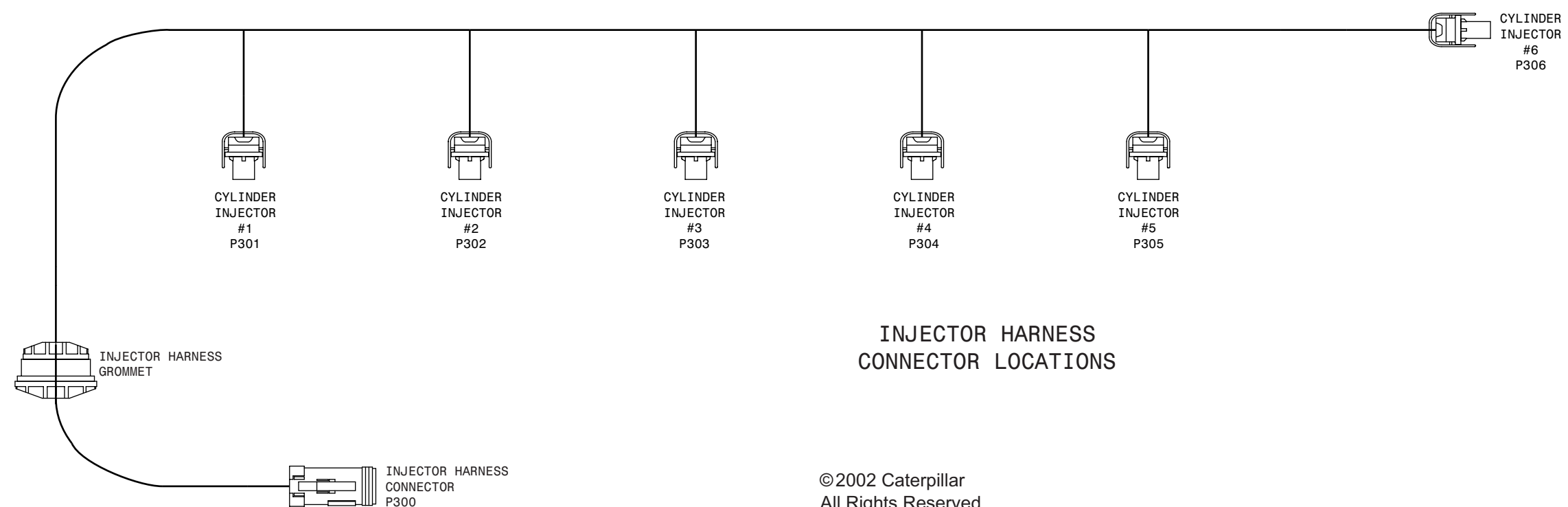

© 2002 Caterpillar
All Rights Reserved

Printed in U.S.A.

Schematic

3126E Truck Engine Electrical System

LEF1-UP

Diagnostic Codes		Flash Codes	
PID-FMI	Description	PID-FMI	Description
0-00	No Detected Faults	55	High Inlet Manifold Temperature Warning
1-11	Cylinder 1 Fault	72	Inlet Manifold Temperature Sensor Open Circuit
2-11	Cylinder 2 Fault	72	Inlet Manifold Temperature Sensor Short Circuit
3-11	Cylinder 3 Fault	73	Very High Inlet Manifold Temperature Warning
4-11	Cylinder 4 Fault	73	Atmospheric Pressure Sensor Open Circuit
5-11	Cylinder 5 Fault	74	Atmospheric Pressure Sensor Short Circuit
6-11	Cylinder 6 Fault	74	High Coolant Temperature Warning
22-13	Check Timing Sensor Calibration	42	Coolant Temperature Sensor Open Circuit
30-08	Invalid PTO Throttle Signal	29	Coolant Temperature Sensor Short Circuit
30-13	PTO Throttle Sensor Calibration	29	Very High Coolant Temperature Warning
41-03	8 Volt Supply Above Normal	21	Secondary Fuel Level Sensor Open Circuit
41-04	8 Volt Supply Below Normal	21	Secondary Fuel Level Sensor Short Circuit
42-11	Injection Actuation Pressure Control Valve Driver	18	Injection Actuation Pressure Out of Range
43-02	Ignition Key Switch Fault	71	Injection Actuation Pressure Sensor Erratic
64-02	Loss of Engine RPM Signal #2	34	Injection Actuation Pressure Sensor Open Circuit
64-11	No Pattern on RPM Speed Sensor #2	34	Injection Actuation Pressure Sensor Short Circuit
70-05	Inlet Air Heater Open Circuit	49	Injection Actuation Pressure Sensor System
70-06	Inlet Air Heater Short Circuit	49	Low or Intermittent Battery
71-00	Idle Shutdown Override	01	Oil Temperature Sensor Open Circuit
71-01	Idle Shutdown Occurrence	47	Oil Temperature Sensor Short Circuit
71-14	PTO Shutdown Timer Occurrence	47	Oil Temperature Sensor Open Circuit
84-00	Vehicle Overspeed Warning	41	PTO Engine Shutdown Switch Short Circuit
84-01	Loss of Vehicle Speed Signal	31	PTO Shutdown Switch Occurrence
84-02	Invalid Vehicle Speed Signal	36	Engine Overspeed Warning
84-08	Vehicle Speed Out of Range	36	Loss of Engine RPM Signal #1
84-10	Vehicle Speed Rate of Change	36	No Pattern on RPM Speed Sensor #1
91-08	Invalid Throttle Signal	32	Theft Deterrent Active
91-13	Throttle Sensor Calibration	28	Engine Cranking with Theft Deterrent Active
96-03	Primary Fuel Level Sensor Open Circuit	44	J1939 Required Data Not Received
96-04	Primary Fuel Level Sensor Short Circuit	44	J1939 Device Not Responding
100-03	Oil Pressure Sensor Open Circuit	24	5 Volt Supply Above Normal
100-04	Oil Pressure Sensor Short Circuit	24	5 Volt Supply Below Normal
100-11	Very Low Oil Pressure	46	Brake Switch #1 Fault
102-03	Boost Pressure Sensor Open Circuit	25	Brake Switch #2 Fault
102-04	Boost Pressure Sensor Short Circuit	25	Incorrect Engine Software
102-07	Excessive Boost Pressure	25	Check Customer or System Parameters
			Truck Manufacturer Parameter Not Programmed

ENGINE HARNESS WIRING DIAGRAM

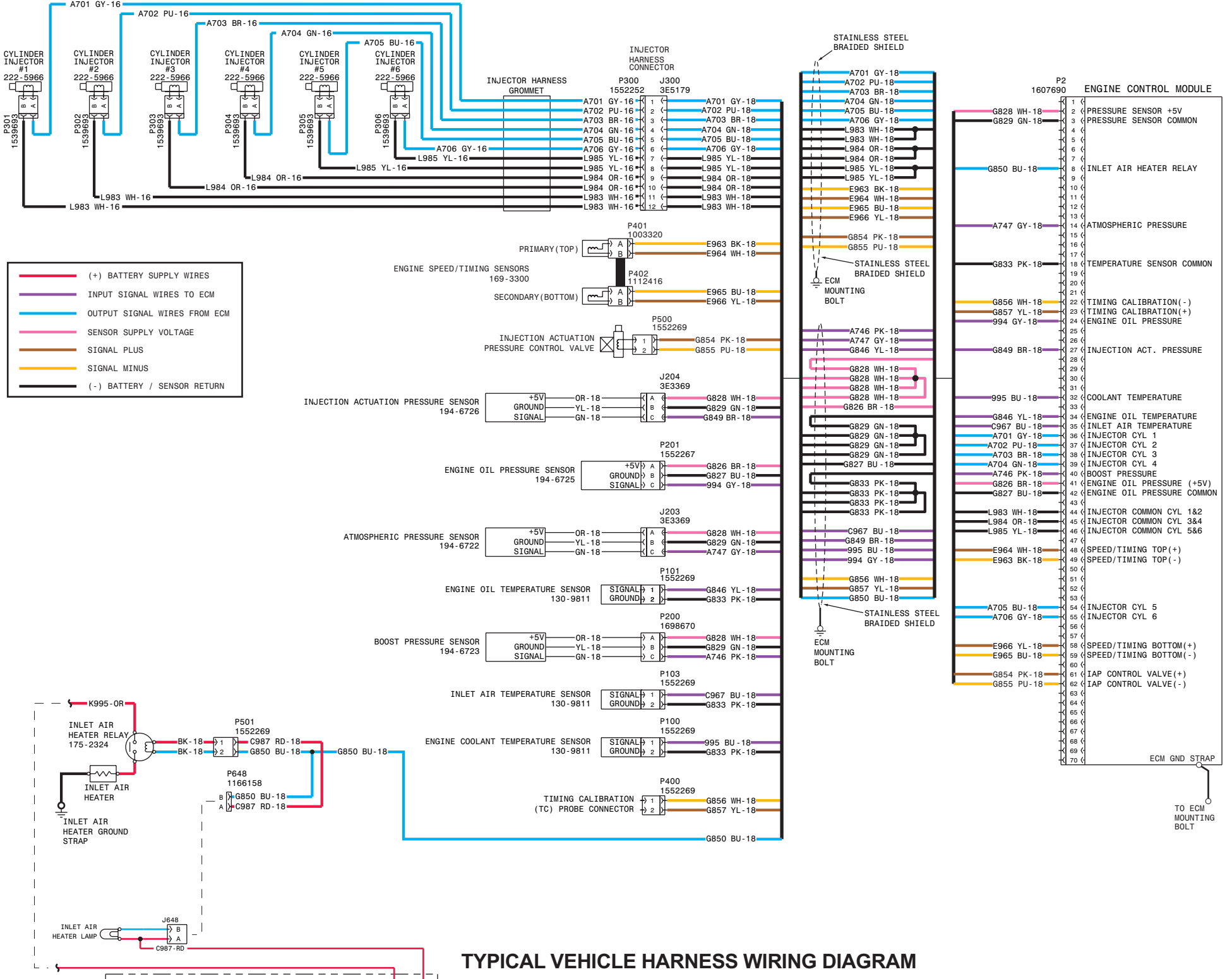

TYPICAL VEHICLE HARNESS WIRING DIAGRAM

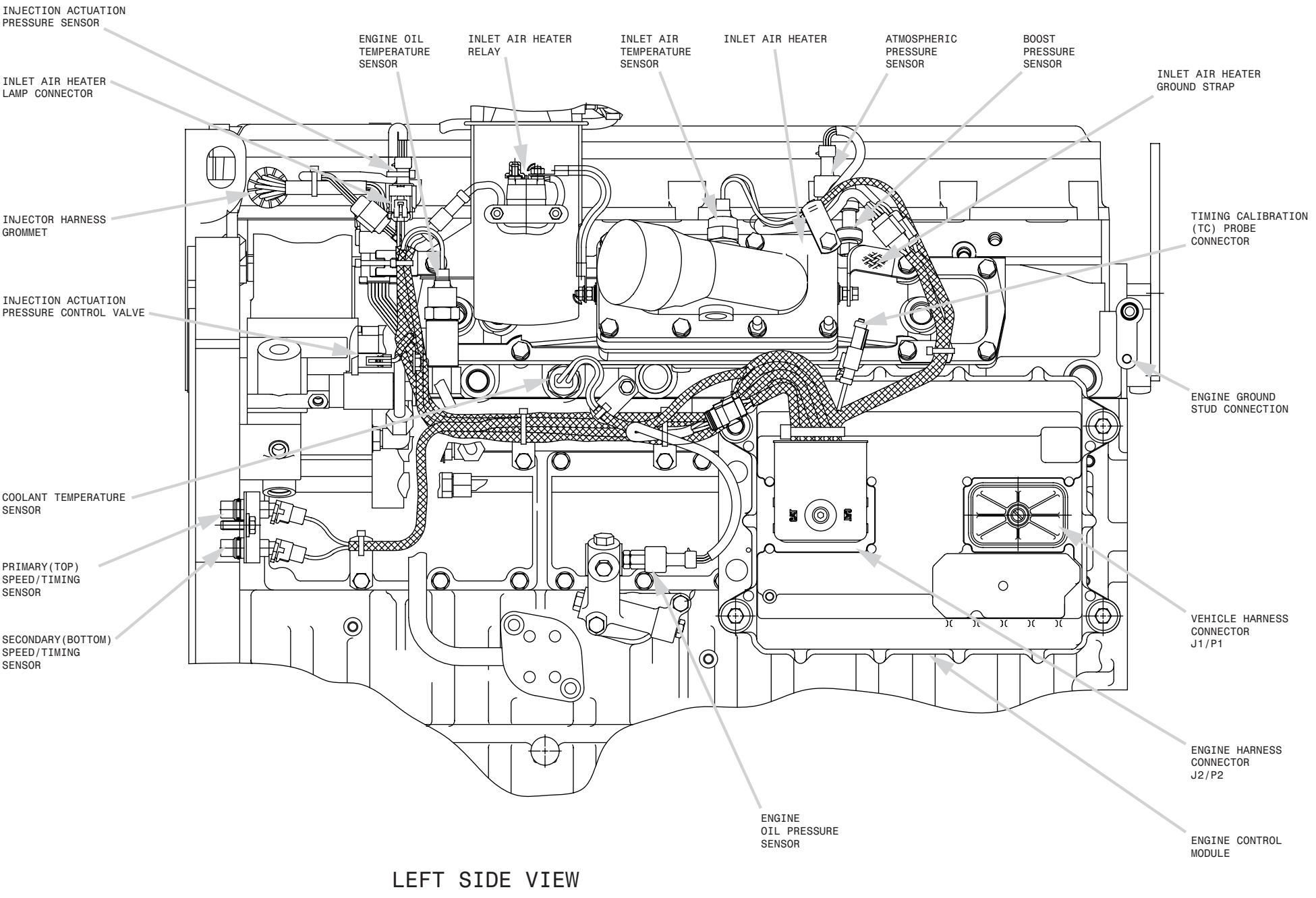
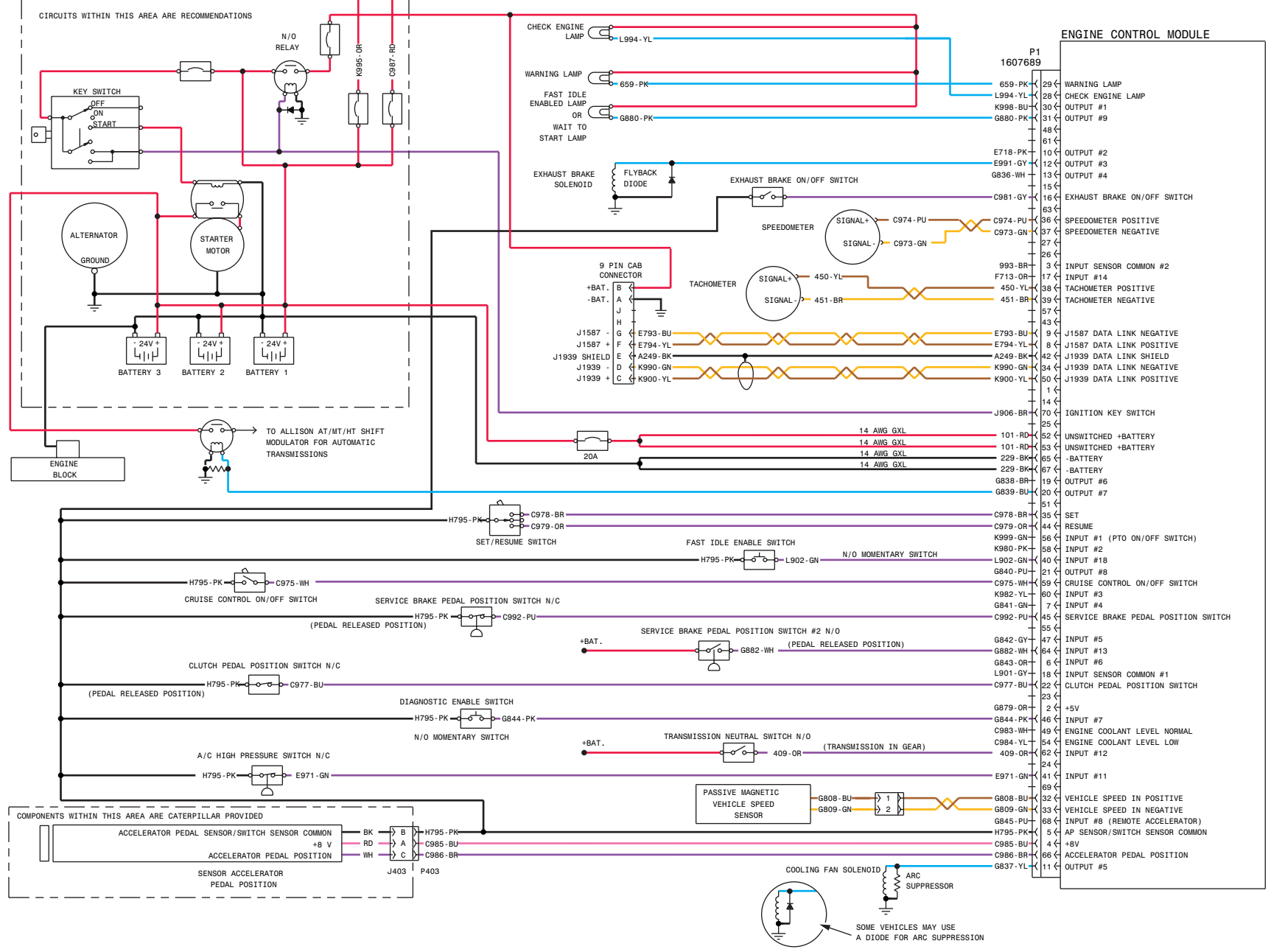

LEFT SIDE VIEW

ENGINE HARNESS CONNECTOR AND SPLICE LOCATIONS

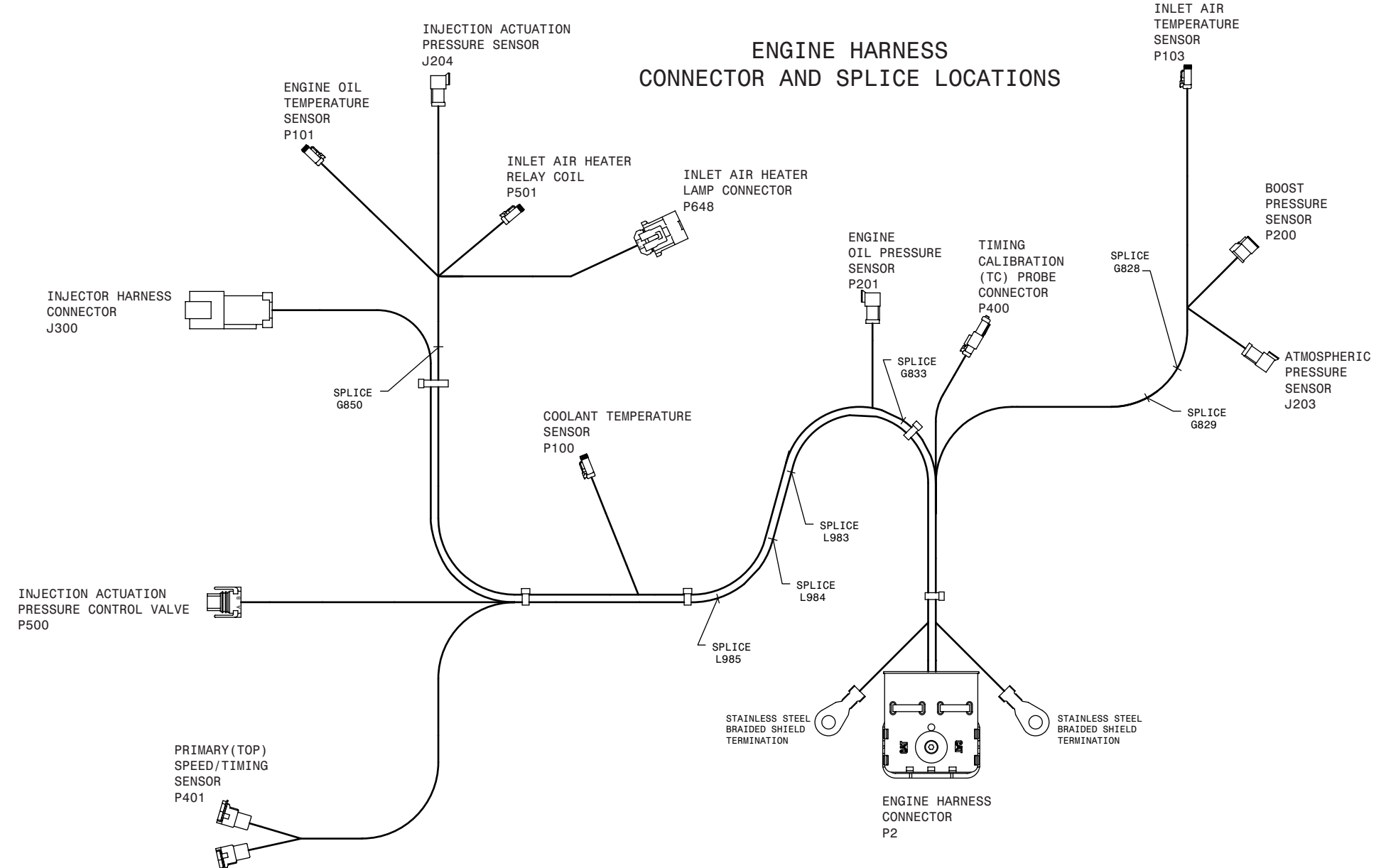

THIS SCHEMATIC IS FOR THE 3126E TRUCK ENGINE (S/N: LEF)
 HARNESS CHG
 190-7421 01 (J2 / ENGINE)
 153-8920 02 (INJECTOR)

REN7898-00

TM 9-2320-312-24

THE METRIC SYSTEM AND EQUIVALENTS

<p>Linear Measure</p> <p>1 Centimeter = 10 Millimeters = 0.01 Meters = 0.3937 Inches 1 Meter = 100 Centimeters = 1000 Millimeters = 39.37 Inches 1 Kilometer = 1000 Meters = 0.621 Miles</p> <p>Weights</p> <p>1 Gram = 0.001 Kilograms = 1000 Milligrams = 0.035 Ounces 1 Kilogram = 1000 Grams = 2.2 Pounds 1 Metric Ton = 1000 Kilograms = 1 Megagram = 1.1 Short Tons</p> <p>Liquid Measure</p> <p>1 Milliliter = 0.001 Liters = 0.0338 Fluid Ounces 1 Liter = 1000 Milliliters = 33.82 Fluid Ounces</p>	<p>Square Measure</p> <p>1 Sq Centimeter = 100 Sq Millimeters = 0.155 Sq Inches 1 Sq Meter = 10,000 Sq Centimeters = 10.76 Sq Feet 1 Sq Kilometer = 1,000,000 Sq Meters = 0.386 Sq Miles</p> <p>Cubic Measure</p> <p>1 Cu Centimeter = 1,000 Cu Millimeters = 0.06 Cu Inches 1 Cu Meter = 1,000,000 Cu Centimeters = 35.31 Cu Feet</p> <p>Temperature</p> <p>$5/9 (^{\circ}\text{F} - 32) = ^{\circ}\text{C}$ 212° Fahrenheit is equivalent to 100° Celsius 90° Fahrenheit is equivalent to 32.2° Celsius 32° Fahrenheit is equivalent to 0° Celsius $9/5 \text{ C}^{\circ} + 32 = \text{F}^{\circ}$</p>
--	--

APPROXIMATE CONVERSION FACTORS

To Change	To	Multiply By
Inches	Centimeters	2.540
Feet	Meters	0.305
Yards	Meters	0.914
Miles	Kilometers	1.609
Sq Inches	Sq Centimeters	6.451
Sq Feet	Sq Meters	0.093
Sq Yards	Sq Meters	0.836
Sq Miles	Sq Kilometers	2.590
Acres	Sq Hectometers	0.405
Cubic Feet	Cubic Meters	0.028
Cubic Yards	Cubic Meters	0.765
Fluid Ounces	Milliliters	29.573
Pints	Liters	0.473
Quarts	Liters	0.946
Gallons	Liters	3.785
Ounces	Grams	28.349
Pounds	Kilograms	0.454
Short Tons	Metric Tons	0.907
Pound-Feet	Newton-Meters	1.356
Pounds per Sq Inch	Kilopascals	6.895
Miles per Gallon	Kilometers per Liter	0.425
Miles per Hour	Kilometers per Hour	1.609

To Change	To	Multiply By
Centimeters	Inches	0.394
Meters	Feet	3.280
Meters	Yards	1.094
Kilometers	Miles	0.621
Sq Centimeters	Sq Inches	0.155
Sq Meters	Sq Feet	10.764
Sq Meters	Sq Yards	1.196
Sq Kilometers	Sq Miles	0.386
Sq Hectometers	Acres	2.471
Cubic Meters	Cubic Feet	35.315
Cubic Meters	Cubic Yards	1.308
Milliliters	Fluid Ounces	0.034
Liters	Pints	2.113
Liters	Quarts	1.057
Liters	Gallons	0.264
Grams	Ounces	0.035
Kilograms	Pounds	2.205
Metric Tons	Short Tons	1.102
Newton-Meters	Pound-Feet	0.738
Kilopascals	Pounds per Sq Inch	0.145
Kilometers per Liter	Miles per Gallon	2.354
Kilometers per Hour	Miles per Hour	0.621

